



US00D987083S

(12) **United States Design Patent** (10) **Patent No.:** **US D987,083 S**  
**Thompson et al.** (45) **Date of Patent:** **\*\* May 23, 2023**

(54) **ABLATION GENERATOR**

(56) **References Cited**

(71) Applicant: **St. Jude Medical, Cardiology Division, Inc.**, St. Paul, MN (US)  
(72) Inventors: **Sara A. Thompson**, Maple Grove, MN (US); **Mark A. Catron**, Superior, CO (US); **Eric Collins**, Superior, CO (US); **Matija Klemenc**, Louisville, CO (US); **Karen M. Kensok**, Minnetonka, MN (US); **John B. Blix**, Maple Grove, MN (US)

U.S. PATENT DOCUMENTS

3,650,277 A 3/1972 Sjostrand et al.  
4,658,819 A 4/1987 Harris et al.  
5,035,694 A 7/1991 Kasprzyk  
5,255,679 A 10/1993 Imran  
5,300,068 A 4/1994 Rosar  
D351,655 S 10/1994 Smith et al.

(Continued)

FOREIGN PATENT DOCUMENTS

WO 97/45157 12/1997  
WO 00/66020 11/2000

(Continued)

(73) Assignee: **St. Jude Medical, Cardiology Division, Inc.**, St. Paul, MN (US)

(\*\*) Term: **15 Years**

OTHER PUBLICATIONS

(21) Appl. No.: **29/774,958**

Robbins, Ivan M. et al, Pulmonary Vein Stenosis After Catheter Ablation of Atrial Fibrillation, Circulation Journal of The American Heart Association, 1998;98:1769-1775.

(22) Filed: **Mar. 19, 2021**

(Continued)

**Related U.S. Application Data**

*Primary Examiner* — Rhea Shields

(60) Continuation of application No. 29/630,310, filed on Dec. 20, 2017, now Pat. No. Des. 914,883, which is a continuation-in-part of application No. 29/546,591, filed on Nov. 24, 2015, now abandoned, which is a division of application No. 29/470,614, filed on Oct. 23, 2013, now Pat. No. Des. 747,491.

(74) *Attorney, Agent, or Firm* — Armstrong Teasdale LLP

(51) **LOC (14) Cl.** ..... **24-02**

(57)

**CLAIM**

(52) **U.S. Cl.**  
USPC ..... **D24/170**

The ornamental design for an ablation generator, as shown and described.

(58) **Field of Classification Search**  
USPC ..... D24/170, 185, 231, 171, 176; D13/112;  
D14/451, 253, 239, 377; D15/199;  
D22/109; D8/72  
CPC ..... A61N 1/007; A61B 17/0483

**DESCRIPTION**

FIG. 1 is a perspective view of an ablation generator, showing our new design.  
FIG. 2 is a front elevation thereof.  
FIG. 3 is a rear elevation thereof.  
FIG. 4 is a right side elevation thereof.  
FIG. 5 is a left side elevation thereof.  
FIG. 6 is a top plan view thereof; and,  
FIG. 7 is a bottom plan view thereof.  
In the drawings, the broken lines are for the purpose of illustrating portions of the ablation generator that form no part of the claimed design.

See application file for complete search history.

**1 Claim, 7 Drawing Sheets**

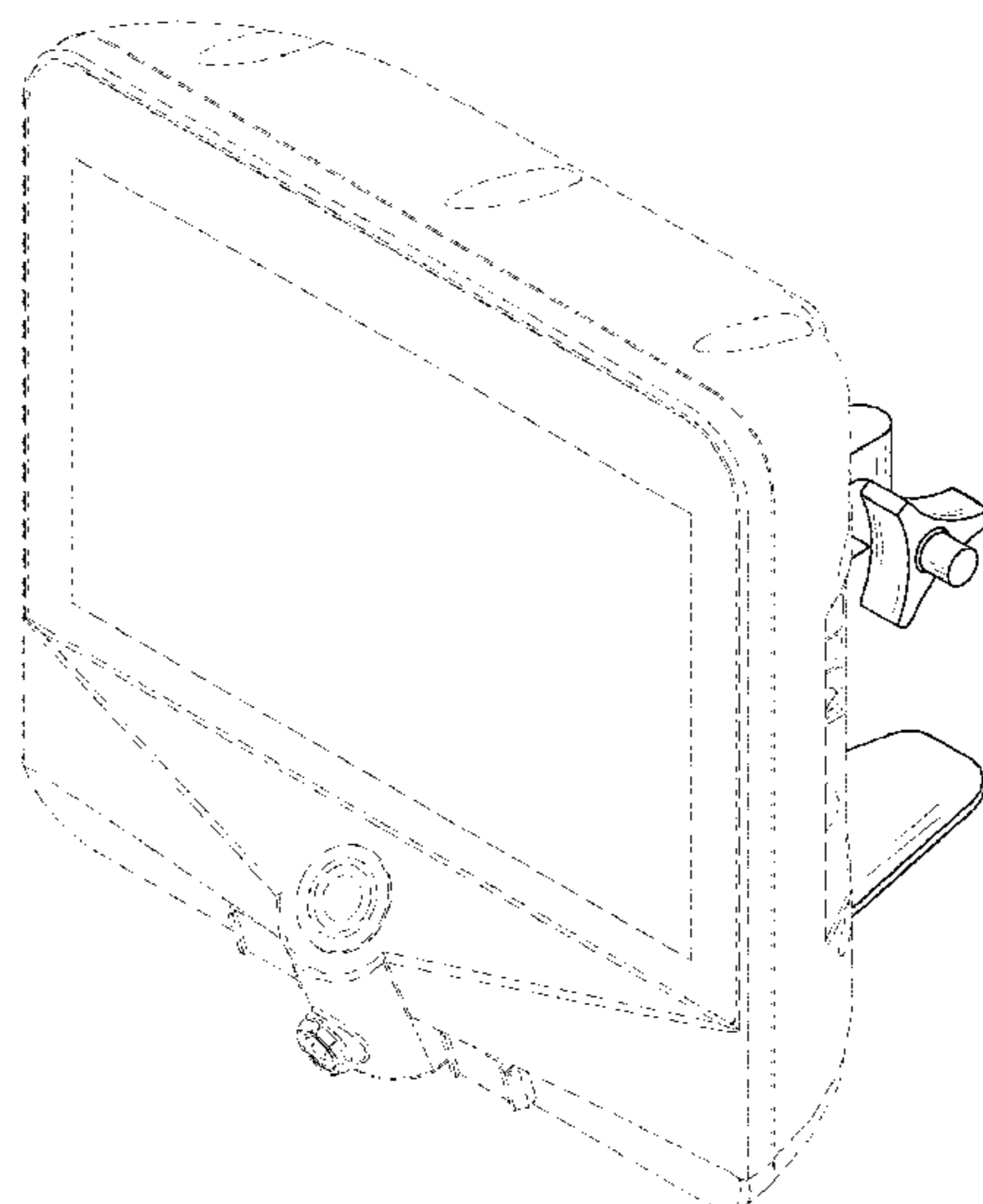

(56)

References Cited

U.S. PATENT DOCUMENTS

5,368,591 A 11/1994 Lennox et al.  
 5,387,233 A 2/1995 Alferness et al.  
 D359,353 S 6/1995 Butter  
 5,465,717 A 11/1995 Imran et al.  
 5,531,779 A 7/1996 Dahl et al.  
 5,598,848 A 2/1997 Swanson et al.  
 5,607,462 A 3/1997 Imran  
 5,628,313 A 5/1997 Webster, Jr.  
 5,676,662 A 10/1997 Fleischhacker et al.  
 5,707,400 A 1/1998 Terry, Jr. et al.  
 5,769,077 A 6/1998 Lindegren  
 5,772,590 A 6/1998 Webster, Jr.  
 5,893,885 A 4/1999 Webster, Jr.  
 5,897,553 A 4/1999 Mulier et al.  
 D411,622 S 6/1999 Hall  
 5,954,649 A 9/1999 Chia  
 5,954,719 A 9/1999 Chen  
 6,004,269 A 12/1999 Crowley et al.  
 6,012,457 A 1/2000 Lesh  
 6,016,437 A 1/2000 Tu et al.  
 6,024,740 A 1/2000 Lesh et al.  
 6,073,048 A 6/2000 Kieval et al.  
 6,096,037 A 8/2000 Mulier et al.  
 6,117,101 A 9/2000 Diederich et al.  
 6,161,543 A 12/2000 Cox et al.  
 6,178,349 B1 1/2001 Kieval  
 6,200,312 B1 3/2001 Zikorus et al.  
 6,216,044 B1 4/2001 Kordis  
 D441,886 S \* 5/2001 Beck ..... D24/231  
 6,233,491 B1 5/2001 Kordis et al.  
 6,283,912 B1 \* 9/2001 Hu ..... A61B 17/0483  
 600/210  
 6,283,951 B1 9/2001 Flaherty et al.  
 6,287,608 B1 9/2001 Levin et al.  
 6,292,695 B1 9/2001 Webster, Jr. et al.  
 6,322,559 B1 11/2001 Daulton et al.  
 6,460,545 B2 10/2002 Kordis  
 6,522,926 B1 2/2003 Kieval et al.  
 D477,408 S 7/2003 Bremley  
 6,613,045 B1 9/2003 Laufer et al.  
 6,616,624 B1 9/2003 Kieval  
 6,635,054 B2 10/2003 Fjield et al.  
 6,656,174 B1 12/2003 Hedge et al.  
 6,669,655 B1 12/2003 Acker et al.  
 6,699,231 B1 3/2004 Serman et al.  
 D491,666 S 6/2004 Kimmell et al.  
 6,748,255 B2 6/2004 Fuimaono et al.  
 6,805,131 B2 10/2004 Kordis  
 6,845,267 B2 1/2005 Harrison et al.  
 6,954,977 B2 10/2005 Maguire et al.  
 6,970,730 B2 11/2005 Fuimaono et al.  
 7,122,031 B2 10/2006 Edwards et al.  
 7,149,574 B2 12/2006 Yun et al.  
 7,155,284 B1 12/2006 Whitehurst et al.  
 7,162,303 B2 1/2007 Levin et al.  
 7,245,955 B2 7/2007 Rashidi  
 D550,357 S 9/2007 Hayamizu  
 D552,241 S 10/2007 Bromley et al.  
 7,291,146 B2 11/2007 Steinke et al.  
 D567,761 S 4/2008 Waaler et al.  
 7,363,076 B2 4/2008 Yun et al.  
 D574,323 S 8/2008 Waaler  
 D576,008 S \* 9/2008 Franks, Jr. .... D8/72  
 7,419,486 B2 9/2008 Kampa  
 7,465,288 B2 12/2008 Dudley et al.  
 7,468,062 B2 12/2008 Oral et al.  
 7,481,803 B2 1/2009 Kesten et al.  
 7,604,645 B2 \* 10/2009 Barzell ..... A61N 5/1007  
 600/459  
 7,653,438 B2 1/2010 Deem et al.  
 7,717,948 B2 5/2010 Demarais et al.  
 7,742,795 B2 6/2010 Stone et al.  
 7,850,685 B2 12/2010 Kunis et al.  
 7,949,407 B2 5/2011 Kaplan et al.  
 8,145,316 B2 3/2012 Deem et al.

8,224,416 B2 7/2012 de la Rama et al.  
 D672,839 S \* 12/2012 Ding ..... D22/109  
 8,343,213 B2 1/2013 Salahieh et al.  
 8,347,891 B2 1/2013 Demarais et al.  
 8,442,639 B2 5/2013 Walker et al.  
 8,454,594 B2 6/2013 Demarais et al.  
 D687,146 S 7/2013 Juzkiw et al.  
 8,545,495 B2 10/2013 Scheib  
 D695,407 S 12/2013 Price et al.  
 D704,839 S 5/2014 Juzkiw et al.  
 D712,352 S 9/2014 George et al.  
 D712,353 S 9/2014 George et al.  
 D712,833 S 9/2014 George et al.  
 D719,265 S \* 12/2014 Wang ..... D24/171  
 9,022,948 B2 5/2015 Wang  
 D747,491 S \* 1/2016 Thompson ..... D24/170  
 D793,559 S \* 8/2017 Thompson ..... D24/170  
 D821,584 S \* 6/2018 DePiano ..... D24/170  
 D829,331 S \* 9/2018 Norton ..... D24/231  
 D835,281 S \* 12/2018 Clifford ..... D24/185  
 D840,542 S \* 2/2019 Lapaev ..... D24/170  
 D849,953 S \* 5/2019 Lapaev ..... D24/170  
 D849,956 S \* 5/2019 Demarest ..... D24/176  
 D854,537 S \* 7/2019 Ackeret ..... D14/253  
 D873,253 S \* 1/2020 Ahrens ..... D14/239  
 D896,390 S \* 9/2020 Scott ..... D24/185  
 D914,883 S \* 3/2021 Thompson ..... D24/170  
 D924,237 S \* 7/2021 Daugirdas ..... D24/185  
 D929,390 S \* 8/2021 Bai ..... D14/253  
 D934,935 S \* 11/2021 Son ..... D15/199  
 D939,502 S \* 12/2021 Lee ..... D14/377  
 D944,736 S \* 3/2022 Gohil ..... D24/107  
 D949,157 S \* 4/2022 Lee ..... D14/451  
 2002/0068885 A1 6/2002 Harhen et al.  
 2002/0120304 A1 8/2002 Mest  
 2003/0050681 A1 3/2003 Pianca et al.  
 2003/0060858 A1 3/2003 Kieval et al.  
 2003/0074039 A1 4/2003 Puskas  
 2003/0114739 A1 6/2003 Fuimaono et al.  
 2003/0216792 A1 11/2003 Levin et al.  
 2003/0233099 A1 12/2003 Danaek et al.  
 2004/0215186 A1 10/2004 Cornelius et al.  
 2005/0288730 A1 12/2005 Deem et al.  
 2006/0089678 A1 4/2006 Shalev  
 2007/0135875 A1 6/2007 Demarais et al.  
 2008/0255478 A1 10/2008 Burdette  
 2009/0076409 A1 3/2009 Wu et al.  
 2010/0016762 A1 1/2010 Thapliyal et al.  
 2010/0094209 A1 4/2010 Drasler et al.  
 2010/0168737 A1 7/2010 Grunewald  
 2010/0249773 A1 9/2010 Clark et al.  
 2010/0268307 A1 10/2010 Demarais et al.  
 2010/0286684 A1 11/2010 Hata et al.  
 2011/0004087 A1 1/2011 Fish et al.  
 2011/0118726 A1 5/2011 de la Rama et al.  
 2011/0137298 A1 6/2011 Nguyen et al.  
 2011/0160720 A1 6/2011 Johnson  
 2011/0213231 A1 9/2011 Hall et al.  
 2011/0257641 A1 10/2011 Hastings et al.  
 2011/0264011 A1 10/2011 Wu et al.  
 2011/0264086 A1 10/2011 Ingle  
 2012/0143097 A1 6/2012 Pike, Jr.  
 2012/0143298 A1 6/2012 Just et al.  
 2012/0296232 A1 11/2012 Ng  
 2012/0323233 A1 12/2012 Maguire et al.  
 2013/0116737 A1 5/2013 Edwards et al.  
 2013/0131743 A1 5/2013 Yamasaki et al.  
 2013/0144251 A1 6/2013 Sobotka  
 2013/0172715 A1 7/2013 Just et al.  
 2014/0330266 A1 11/2014 Thompson

FOREIGN PATENT DOCUMENTS

WO 01/00273 1/2001  
 WO 01/22897 4/2001  
 WO 02/26314 4/2002  
 WO 03/082080 10/2003  
 WO 2006/041881 4/2006  
 WO 2007/149970 12/2007

(56)

**References Cited**

## FOREIGN PATENT DOCUMENTS

WO	2008/141150	11/2008
WO	2008/151001	12/2008
WO	2012/064818	5/2012
WO	2012/106492	8/2012

## OTHER PUBLICATIONS

- Rocha-Singh, Krishna J., Catheter-Based Sympathetic Renal Denervation A Novel Strategy for the Treatment of Resistant Hypertension, *Endovascular Today*, Aug. 2009, 52-56.
- Rocha-Singh, Krishna J., Renal Artery Denervation: A Brave New Frontier, *Endovascular Today*, Feb. 2012, 45-53.
- Sanderson, John E. et al, Effect of B-Blockade on Baroreceptor and Autonomic Function in Heart Failure, *Clinical Science* (1999) 96, 137-146.
- Santos, Mario et al, Renal Sympathetic Denervation in Resistant Hypertension, *World J Cardiol* Apr. 26, 2013; 5(4) 94-101.
- Savard, Sebastien et al, Eligibility for Renal Denervation in Patients With Resistant Hypertension When Enthusiasm Meets Reality in Real-Life Patients, *J Am Coll CardioL* 2012;60(23):2422-2424.
- Schauerte, Patrick et al, Catheter Ablation of Cardiac Autonomic Nerves for Prevention of Vagal Atrial Fibrillation, *Circulation Journal of The American Heart Association*, 2000, 102:2774-2780.
- Schlaich, Markus P. et al, International Expert Consensus Statement: Percutaneous Transluminal Renal Denervation for the Treatment of Resistant Hypertension, *Journal of the American College of Cardiology* vol. 62, Issue 22, Dec. 3, 2013, pp. 2031-2045.
- Schlaich, Markus P. et al, Renal Denervation as a Therapeutic Approach for Hypertension Novel Implications for an Old Concept, *Hypertension Journal of The American Heart Association*, 2009;54:1195-1201.
- Schlaich, Markus P. et al, Renal Sympathetic-Nerve Ablation for Uncontrolled Hypertension, *The New England Journal of Medicine*, 2009; 361:932-934.
- Schmieder, Rolande. et al, ESH Position Paper: Renal Denervation—An Interventional Therapy of Resistant Hypertension, *Journal of Hypertension*, 2012, 30:837-841.
- Schmieder, Roland E. et al, Updated EHS Position Paper on Interventional Therapy of Resistant Hypertension, *EuroIntervention*, May 2013; 9:R58-R66.
- Sellers, Alfred M. et al, Adrenalectomy and Sympathectomy for Hypertension Ten Year Survival, *Archives of Surgery*, vol. 89, Nov. 1964, 880-886.
- Sen, SK, Some Observations on Decapsulation and Denervation of the Kidney, *The British Journal of Urology*, vol. 8, Issue 4, Dec. 1936, 319-328.
- Shiraki, Iwao William, Correction of Renal Hypertension by Ligation of Stenotic Segmental Renal Artery, *Urology*, vol. IX, No. 3, Mar. 1977, 296-298.
- Shonai, T Akaharu et al, Renal Artery Aneurysm: Evaluation with Color Doppler Ultrasonography Before and After Percutaneous Transarterial Embolization, *J Ultrasound Med* 19:277-280, 2000.
- Silver, Donald et al, Renovascular Hypertension From Renal Artery Compression by Congenital Bands, *Annals of Surgery*, Feb. 1976, 161-166.
- Smith, Gardner W. et al, Surgical Results and the Diagnostic Evaluation of Renovascular Hypertension, *Annals of Surgery*, May 1968, 669-680.
- Smith, Harold P. et al, Radiofrequency Neurolysis in a Clinical Model Neuropathological Correlation, *J Neurosurg* 55:246-253, 1981.
- Smithwick, RH., An Evaluation of the Surgical Treatment of Hypertension, *The Bulletin*, Nov. 1949; 25(11):698-716.
- Smithwick, Reginald H. et al., Splanchnicectomy for Essential Hypertension, *The Journal of the American Medical Association*, vol. 152, No. 16, Aug. 1953, 1501-1504.
- Solis-Herruzo, Ja et al, Effects of Lumbar Sympathetic Block on Kidney Function in Cirrhotic Patients with Hepatorenal Syndrome, *Journal of Hepatology*, 1987; 5: 167-173.
- Sowers, James R et al, Diabetes, Hypertension, and Cardiovascular Disease: An Update, *Hypertension Journal of The American Heart Association*, 2001;37:1053-1059.
- Stanley, James C., Surgical Treatment of Renovascular Hypertension, *The American Journal of Surgery*, vol. 174, Aug. 1997, 102-110.
- Stella, Andrea et al, Effects of Reversible Renal Denervation on Haemodynamic and Excretory Functions of the Ipsilateral and Contralateral Kidney in the Cat, *Journal of Hypertension* 1986, 4: 181-188.
- Stuart, Candace, *Newest Frontier in Cardiac Care: Kidneys; Cardiovascular Business*, Dec. 13, 2012.
- Stuart, Mary, *Masterminds of Ardian: An Interview With Inventors Mark Gelfand and Howard Levin*, *Windhover Information, Start-Up* Jan. 1, 2011.
- Sun, Yingxian et al, Risk of Coronary Stenosis with Venous Ablation for Epicardial Accessory Pathways, *PACE*, Apr. 2001, Part 11, vol. 24, 605.
- Swartz, John F. et al, Radiofrequency Endocardial Catheter Ablation of Accessory Atrioventricular Pathway Atrial Insertion Sites, *Circulation Journal of The American Heart Association*, 1993;87:487-499.
- Teigen, Corey L et al, Segmental Renal Artery Embolization for Treatment of Pediatric Renovascular Hypertension, *Journal of Vascular and Interventional Radiology*, 1992; 3:111-117.
- Teixeira, Maria Do Carmo et al, 1992; Role of the Peripheral Renin Profile in Predicting Blood Pressure Control Mter Bilateral Nephrectomy in Renal-Transplanted Patients, *Nephrol Dial Transplant* (1998) 13: 2092-2097.
- Teo, W S et al, Radiofrequency Catheter Ablation of Accessory Pathways: The Initial Experience in Singapore, *Singapore Medical Journal*, 1994; vol. 35:36-40.
- Thiebot, J. et al, Bilateral Nephrectomy by Embolization of the Renal Arteries: A Report on Five Cases (author's transl), *Sem Hop*. Apr. 8-15, 1980;56(13-14):670-5.
- Thomas, George et al, Renal Denervation to Treat Resistant Hypertension: Guarded Optimism, *Cleveland Clinic Journal of Medicine*, vol. 79, No. 7, Jul. 2012, 501-510.
- Thomas, Natalie A., Secondary Consideration in Nonobviousness Analysis: The Use of Objective Indicia Following KSR V. Teleflex, *NYU Law Review*, vol. 86, No. 6, Dec. 2011, 2070-2112.
- Ting, Chih-Tai et al, Arterial Hemodynamics in Human Hypertension Effects of Angiotensin Converting Enzyme Inhibition, *Hypertension Journal of The American Heart Association*, 1993;22:839-846.
- Uchida, Fumiya et al, Effect of Radiofrequency Catheter Ablation on Parasympathetic Denervation: A Comparison Of Three Different Ablation Sites, *PACE*, vol. 21, Nov. 1998, Part 11, 2517-2521.
- Valente, John F. et al, Laparoscopic Renal Denervation for Intractable ADPKD-Related Pain, *Nephrol Dial Transplant* (2001) 16:160.
- Villarreal, Daniel et al, Effects of Renal Denervation on Postprandial Sodium Excretion in Experimental Heart Failure, *American Journal of Physiology*, May 1994;266(5 Pt 2):R1599-R1604.
- Vonend, Oliver et al, Secondary Rise in Blood Pressure After Renal Denervation, *The Lancet*, vol. 380, Issue 9843, p. 778, Aug. 25, 2012.
- Vujaskovic, Z. et al, Effects of Intraoperative Hyperthermia on Canine Sciatic Nerve: Histopathologic and Morphometric Studies, *Int. J. Hyperthermia*, 1994, vol. 10, No. 6, 845-855.
- Webb, RL. et al, Functional Identification of the Central Projections of Afferent Renal Nerves, *Clin. and Exper-Theory and Practice*, Ag(SupplI), 47-57 (1987).
- Weinstock, Marta et al, Renal Denervation Prevents Sodium Retention and Hypertension in Salt-Sensitive Rabbits with Genetic Baroreflex Impairment, *Clinical Science* (1996) 90, 287-293.
- Wilcox, Josiah N., *Scientific Basis Behind Renal Denervation for the Control of Hypertension*, Medtronic, Inc., Dec. 2012, 38 pages.

(56)

**References Cited**

## OTHER PUBLICATIONS

- Winternitz, Sherry R. et al, Role of the Renal Sympathetic Nerves in the Development and Maintenance of Hypertension in the Spontaneously Hypertensive Rat, *Journal of Clinical Investigation*, vol. 66Nov. 1980, 971-978.
- Wolf-Maier, Katharina et al, Hypertension Treatment and Control in Five European Countries, Canada, and the United States, *Hypertension*. 2004;43:10-17.
- Worthley, Stephen G. et al, Renal Denervation: How Do You Measure Success?, presentation 28 pages; Jul. 30, 2013.
- Wyss, J.M. et al, Sensory Denervation of the Kidney Attenuates Renovascular Hypertension in the Rat, *Am J Physiol Heart Circ Physiol* 250:H82-H86, 1986.
- Yamada, Yut Aka et al, Age-Related Changes in Muscle Sympathetic Nerve Activity in Essential Hypertension, *Hypertension Journal of The American Heart Association*, 1989;13:870-877.
- Young, Robert R. et al, Reversible Block of Nerve Conduction by Ultrasound Ultrasonic Blocking of Nerve Fibers, *Arch Neurol*. 1961;4(1 ):83-89.
- Moak, Jeffrey P\_ et al, Case Report: Pulmonary Vein Stenosis Following RF Ablation of Paroxysmal Atrial Fibrillation: Successful Treatment with Balloon Dilation, *Journal of Interventional Cardiac Electrophysiology*, Dec. 2000, 4:621-631.
- Mogil, Robert A\_ et al, Renal Innervation and Renin Activity in Salt Metabolism and Hypertension, *American Journal of Physiology*, vol. 216, No. 4, Apr. 1969, 693-697.
- Morita, Hironobu et al, Neural Control of Urinary Sodium Excretion During Hypertonic NaCl Load in Conscious Rabbits: Role of Renal and Hepatic Nerves and Baroreceptors, *Journal of the Autonomic Nervous System*, 34 (1991) 157-170.
- Morrissey, D.M. et al, Sympathectomy in the Treatment of Hypertension, *The Lancet*, Feb. 1953, 403-408.
- Mort Ara, Andrea et al, Nonselective Beta-Adrenergic Blocking Agent, Carvedilol, Improves Arterial Baroflex Gain and Heart Rate Variability in Patients With Stable Chronic Heart Failure, *Journal of the American College of Cardiology*, vol. 36, No. 5, 2000, 1612-1618.
- Moss, Jonathan, *Interventional Radiology and Renal Denervation*, Interventions, vol. 13, Issue 3, 2013; Nov. 28, 2013.
- Naghavi, Morteza et al, Thermography Basket Catheter: In Vivo Measurement of the Temperature of Atherosclerotic Plaques for Detection of Vulnerable Plaques, *Catheterization and Cardiovascular Interventions* 59:52-59 (2003).
- Naidoo, N. et al, Thoracic Splanchnic Nerves: Implications for Splanchnic Denervation, *Journal of Anatomy*, Nov. 2001;199(Pt 5):585-590.
- Nakagawa, A. et al, Selective Ablation of Porcine and Rabbit Liver Tissue Using Radiofrequency: Preclinical Study, *European Surgical Research*, 1999;31:371-379.
- Nakagawa, Hiroshi et al, Inverse Relationship Between Electrode Size and Lesion Size During Radiofrequency Ablation With Active Electrode Cooling, *Circulation* Aug. 4, 1998;98(5):458-465.
- Nanni, Gregg s\_ et al, Control of Hypertension by Ethanol Renal Ablation, *Radiology* 148: 51-54, Jul. 1983.
- Ndegwa, S., Catheter-Based Renal Denervation for Treatment-Resistant Hypertension [Issues in emerging health technologies issue 121]. Ottawa: Canadian Agency for Drugs and Technologies in Health; Mar. 2013.
- Neutel, Joel M., Hypertension and Its Management: A Problem in Need of New Treatment Strategies, *Journal of Renin-Angiotensin-Aldosterone System* 2000 1: S10-S13.
- Newcombe, C.P. et al, Sympathectomy for Hypertension, *British Medical Journal*, Jan. 1959, 142-144.
- Ng, Fu Siong et al, Catheter Ablation of Atrial Fibrillation, *Clinical Cardiology*, 25, 384-394 (2002).
- Norman, Roger A. et al, Role of the Renal Nerves in One-Kidney, One Clip Hypertension in Rats, *Hypertension Journal of The American Heart Association*, 1984;6:622-626.
- Nozawa, Takashi et al, Effects of Long-Term Renal Sympathetic Denervation on Heart Failure After Myocardial Infarction in Rats, *Heart Vessels* (2002) 16:51-56.
- O'Connor, Brian K. et al, Radiofrequency Ablation of a Posteroseptal Accessory Pathway Via the Middle Cardiac vein in a Six-Year-Old Child, *PACE*, vol. 20, Oct. 1997, Part 1, 2504-2507.
- O'Hagen, Kathleen P. et al, Renal Denervation Decreases Blood Pressure in DOCA-Treated Miniature Swine With Established Hypertension, *American Journal of Hypertension*, 1990; 3:62-64.
- Oliveira, Vera LL. et al, Renal Denervation Normalizes Pressure and Baroreceptor Reflex in High Renin Hypertension in Conscious Rats, *Hypertension* vol. 19, No. 2 Feb. 1992, Supplement 11, 11-17-11-21.
- Dmran, Heyder et al, Echocardiographic Imaging of Coronary Sinus Diverticula and Middle Cardiac Veins in Patients with Preexcitation Syndrome: Impact—on Radiofrequency Catheter Ablation of Posteroseptal Accessory Pathways, *PACE*, vol. 18, Jun. 1995, 1236-1243.
- Oparil, Suzanne et al, Renal Nerve Ablation: Emerging Role in Therapeutics; *Blood Pressure*, Oct. 2011, vol. 20, No. 5 , pp. 253-255.
- Oral, Hakan et al, Pulmonary Vein Isolation for Paroxysmal and Persistent Atrial Fibrillation, *Circulation Journal of the American Heart Association*, 2002;105:1077-1081.
- Osborn, Jeffrey L. et al, Long-Term Increases in Renal Sympathetic Nerve Activity and Hypertension, *Clinical and Experimental Pharmacology and Physiology* (1997) 24,72-76.
- Osborn, John W., The Sympathetic Nervous System and Long-Term Regulation of Arterial Pressure: What Are the Critical Questions?, *Clinical and Experimental Pharmacology and Physiology* (1997) 24, 68-71.
- Ou, Baiqing et al, Baroreflex Sensitivity Predicts the Induction of Ventricular Arrhythmias by Cesium Chloride in Rabbits, *Japanese Circulation Journal*, 1999; 63: 783-788.
- Oz, Mehmet, Pressure Relief, *Time Magazine*, Monday, Jan. 9, 2012.
- Page, Irvine H. et al, Mechanisms, Diagnosis and Treatment of Hypertension of Renal Vascular Origin, *Annals of Internal Medicine*, Aug. 1959, vol. 51, No. 2, 196-211.
- Page, Irvine H. et al, Mechanisms, Diagnosis and Treatment of Hypertension of Renal Vascular Origin; *Annals of Internal Medicine*, Aug. 1959;51:196-211.
- Page, Irvine H. et al, The Effect of Renal Denervation on the Level of Arterial Blood Pressure and Renal Function in Essential Hypertension, *Journal of Clinical Investigation*, 1935;14(1):27-30.
- Page, Irvine H. et al, The Effects of Renal Denervation on Patients Suffering from Nephritis, *J Clin Invest*. 1935;14(4):443-458.
- Page, Irvine H., The Effect of Renal Efficiency of Lowering Arterial Blood Pressure in Cases of Essential Hypertension and Nephritis, *Journal of Clinical Investigation*, Nov. 1934; 13(6): 909-915.
- Page, Max, Section of Surgery, Discussion on the Surgical Treatment of Hypertension, *Proceedings of the Royal Society of Medicine*, vol. XLI, Feb. 1948, 359-372.
- Papademetriou, Vasiliou, Hypertension and the Simplicity Renal Denervation System, *Scientific Background*, www.medtronic.com, 2011.
- Pappone, Carlo et al, Circumferential Radiofrequency Ablation of Pulmonary Vein Ostia: A New Anatomic Approach for Curing Atrial Fibrillation, *Circulation, Journal of The American Heart Association*, 2000;102:2619-2628.
- Parati, Gianfranco et al, The Human Sympathetic Nervous System: Its Relevance in Hypertension and Heart Failure, *European Heart Journal* (2012) 33, 1058-1066.
- Parmar, Arundhati, Analyst: Medtronic Will Likely Acquire Another Hypertension Therapy Firm, *Medcity News*, Apr. 27, 2012; 3:06 p.m.; medcitynews.com.
- Pavlovich, Christian P. et al, Percutaneous Radio Frequency Ablation of Small Renal Tumors: Initial Results; *The Journal of Urology*, vol. 167, 10-15, Jan. 2002.
- Pearce, John A\_ et al, Blood Vessel Architectural Features and Their Effect on Thermal Phenomena, *Critical Reviews*, vol. CR75,, Bellingham, WA: SPIE Optical Engineering Press; 2000, p. 231-277.

(56)

## References Cited

## OTHER PUBLICATIONS

- Peet, Max Minor, Hypertension and Its Surgical Treatment by Bilateral Supradiaphragmatic Splanchnicectomy, *American Journal of Surgery*, vol. 75, Issue 1, Jan. 1948, 48-68.
- Perry, C. Bruce, Malignant Hypertension Cured by Unilateral Nephrectomy, *British Heart Journal*, Jul. 1945; 7(3):139-142.
- Persu, Alexandre et al, Renal Denervation: Ultima Ratio or Standard in Treatment-Resistant Hypertension, *Hypertension Journal of The American Heart Association*, Sep. 2012;60(3):596-606.
- Peterson, Helen Hogh et al, Lesion Dimensions During Temperature-Controlled Radiofrequency Catheter Ablation of Left Ventricular Porcine Myocardium Impact of Ablation Site, Electrode Size, and Convective Cooling, *Circulation Journal of The American Heart Association*, 1999;99:319-325.
- Plouin, Pierre-Francois et al, Blood Pressure Outcome of Angioplasty in Atherosclerotic Renal Artery Stenosis A Randomized Trial, *Hypertension Journal of The American Heart Association*, 1998;31:823-829.
- Poutasse, Eugene F., Surgical Treatment of Renal Hypertension, *American Journal of Surgery*, vol. 107, Jan. 1964, 97-103.
- Pugsley, MK et al, The Vascular System An Overview of Structure and Function, *Journal of Pharmacological and Toxicological Methods* 44 (2000) 333-340.
- Putney, John Paul, Are Secondary Considerations Still "Secondary"? An Examination of Objective Indicia of Nonobviousness Five Years After KSR, *Intellectual Property Brief*, vol. 4, Issue 2, Article 5, 2012, 45-59.
- Ramsay, Lawrence E. et al, Blood Pressure Response to Percutaneous Transluminal Angioplasty for Renovascular Hypertension: An Overview of Published Series; *British Medical Journal* Mar. 3, 1990; 300(6724): 569-572.
- Rippy, Marian K. et al, Catheter-Based Renal Sympathetic Denervation: Chronic Preclinical Evidence for Renal Artery Safety, *Clin Res Cardiol* (2011) 100:1095-1101.
- Ritz, Eberhard, New Approaches to Pathogenesis and Management of Hypertension, *Clin J Am Soc Nephrol* 4: 1886-1891, 2009.
- Jaff, Michael R. et al, Kidney Stenting Lowers Blood Pressure in Patients with Severe Hypertension; Catheterization and Cardiovascular Interventions; Published Online: Jun. 27, 2012 (DOI: 10.1002/ccd.24449); Print Issue Date: Sep. 2012. URL: <http://onlinelibrary.wiley.com/doi/10.1002/ccd.24449/abstract>.
- Jain, Mudit K. et al, A Three-Dimensional Finite Element Model of Radiofrequency Ablation with Blood Flow and Its Experimental Validation, *Annals of Biomedical Engineering*, vol. 28, pp. 1075-1084, 2000.
- Jais, Pierre et al, Efficacy and Safety of Septal and Left-Atrial Linear Ablation for Atrial Fibrillation, *The American Journal of Cardiology*, vol. 84 (9A), Nov. 1999, 139R-146R.
- Janssen, Ben Ja et al, Frequency-Dependent Modulation of Renal Blood Flow by Renal Nerve Activity in Conscious Rabbits, *American Journal of Physiology*, 1997, 273:R597-R608.
- Janssen, Ben Ja et al., Renal Nerves in Hypertension, *Miner Electrolyte Metab* 1989;15:74-82.
- Jin, Yu et al, No Support for Renal Denervation in a Meta-Analysis, *JACC* vol. 62, No. 21, 2013 Correspondence Nov. 19/26, 2013:2029-30.
- Kaltenbach, Benjamin et al, Renal Artery Stenosis After Renal Sympathetic Denervation, *J Am Coll Cardiol*. Dec. 25, 2012;60(25):2694-5.
- Kaltenbach, Benjamin et al, Renal Sympathetic Denervation as Second-Line Therapy in Mild Resistant Hypertension: A Pilot Study, *Catheterization and Cardiovascular Interventions* 81:335-339; Feb. 2013.
- Kamiya, Atsunori et al, Parallel Resetting of Arterial Baroreflex Control of Renal and Cardiac Sympathetic Nerve Activities During Upright Tilt in Rabbits, *Am J Physiol Heart Circ Physiol* 298: H1966-H1975, 2010.
- Kandzari, Davide. et al, Catheter-Based Renal Denervation for Resistant Hypertension: Rationale and Design of the Symplicity HTN-3 Trial, *Clin. Cardiol.* 35, 9, 528-535 (2012).
- Kapur, Leonardo et al, Radiofrequency Ablation for Chronic Pain Control, *Current Pain and Headache Reports* 2001, 5:517-525.
- Kassab, Salah et al, Renal Denervation Attenuates the Sodium Retention and Hypertension Associated with Obesity, *Hypertension* vol. 25, No. 4, Part 2 Apr. 1995.
- Katholi, Richard E. et al, Decrease in Peripheral Sympathetic Nervous System Activity following Renal Denervation or Unclipping in the One-Kidney One-Clip Goldblatt Hypertensive Rat, *The Journal of Clinical Investigation*, Jan. 1982;69(1):55-62.
- Katholi, Richard E. et al, Role of the Renal Nerves in the Pathogenesis of One-Kidney Renal Hypertension in the Rat, *Hypertension*. 1981;3:404-409.
- Katholi, Richard E. et al, The Role of Renal Sympathetic Nerves in Hypertension: Has Percutaneous Renal Denervation Refocused Attention on Their Clinical Significance?; *Progress in Cardiovascular Disease* 52 (2009) 243-48.
- Katritsis, Demosthenes et al, Recurrence of Left Atrium-Pulmonary Vein Conduction Following Successful Disconnection in Asymptomatic Patients, *Europace* (2004) 6, 425e432.
- Killip 111, Thomas, Oscillation of Blood Flow and Vascular Resistance During Mayer Waves, *Circulation Research*, vol. XI, Dec. 1962, 987-993.
- Kingwell, Bronwyn A. et al, Assessment of Gain of Tachycardia and Bradycardia Responses of Cardiac Baroreflex, *Am J Physiol Heart Circ Physiol* 260:H1254-H1263, 1991.
- Kirch Heim, H\_ et al, Sympathetic Modulation of Renal Hemodynamics, Renin Release and Sodium Excretion, *Klin Wochenschr* (1989) 67: 858-864.
- Klein, Ge et al, Endovascular Treatment of Renal Artery Aneurysms with Conventional Non-Detachable Microcoils and Guglielmi Detachable Coils, *Br J Urol*. Jun. 1997; 79(6):852-860.
- Knight, Eric Let al, Predictors of Decreased Renal Function in Patients with Heart Failure During Angiotensin-Converting Enzyme Inhibitor Therapy: Results from the Studies of Left Ventricular Dysfunction (SOLVD), *American Heart Journal*, vol. 138, No. 5, Part 1, Nov. 1999, 849-855.
- Koepke, John P. et al, Functions of the Renal Nerves, *The Physiologist*, vol. 28, No. 1, Feb. 1985, 47-52.
- Kompanowska-Jeziarska, Elzbieta et al, Early Effects of Renal Denervation in the Anaesthetized Rat: Natriuresis and Increased Cortical Blood Flow, *Journal of Physiology* (2001), 531.2, pp. 527-534.
- Krum, Henry et al, Catheter-Based Renal Sympathetic Denervation for Resistant Hypertension: A Multicentre Safety and Proof-of-Principle Cohort Study, *www.thelancet.com* vol. 373 Apr. 11, 2009 1275-1281.
- Krum, Henry et al, Device-Based Antihypertensive Therapy: Therapeutic Modulation of the Autonomic Nervous System, *Circulation*. 2011 ;123:209-215.
- La Grange, Ronald G. et al, Selective Stimulation of Renal Nerves in the Anesthetized Dog: Effect on Renin Release During Controlled Changes in Renal Hemodynamics, *Circulation Research*, *Journal of The American Heart Association*, 1973;33:704-712.
- Labeit, Alexander Michael et al, Changes in the Prevalence, Treatment and Control of Hypertension in Germany? A Clinical-Epidemiological Study of 50.000 Primary Care Patients, *Plos One*, Dec. 2012, vol. 7, Issue 12, e52229, 1-11.
- Labonte, Sylvain, Numerical Model for Radio-Frequency Ablation of the Endocardium and its Experimental Validation, *IEEE Transactions on Biomedical Engineering*, vol. 41, No. 2. Feb. 1994, 108-115.
- Lambert, Gavin W. et al, Health-Related Quality of Life After Renal Denervation in Patients With Treatment-Resistant Hypertension, *Hypertension*. 2012;60:1479-1484.
- Lee, Sang Joon et al, Ultrasonic Energy in Endoscopic Surgery, *Yonsei Medical Journal*, vol. 40, No. 6, pp. 545-549, 1999.
- Leertouwer, Trude C. et al, In-Vitro Validation, with Histology, of Intravascular Ultrasound in Renal Arteries, *Journal of Hypertension* 1999, vol. 17 No. 2, 271-277.
- Leishman, Awd., Hypertension—Treated and Untreated, *British Medical Journal*, May 1959, 1361-1368.

(56)

## References Cited

## OTHER PUBLICATIONS

- Leonard, Bridget L. et al, Differential Regulation of the Oscillations in Sympathetic Nerve Activity and Renal Blood Flow Following Volume Expansion, *Autonomic Neuroscience: Basic and Clinical* 83 (2000) 19-28.
- Levin, Stephen, Ardian: Succeeding Where Drugs Fail Treating Hypertension in the Gath Lab, *In Vivo: The Business & Medicine Report*, vol. 27, No. 10, Nov. 2009.
- Litynski, Grzegorz S., Kurt Semm and the Fight against Skepticism: Endoscopic Hemostasis, Laparoscopic Appendectomy, and Semm's Impact on the "Laparoscopic Revolution", *JLS*. Jul.-Sep. 1998; 2(3): 309-313.
- Lu, David S.K. et al, Effect of Vessel Size on Creation of Hepatic Radiofrequency Lesions in Pigs: Assessment of the Heat Sink Effect, *American Journal of Radiology*, 178, Jan. 2002, 47-51.
- Luscher, Thomas F. et al, Renal Nerve Ablation After Symplicity HTN-3: Confused at the Higher Level?; *European Heart Journal*, doi:10.1093/eurheartj/ehu195; May 14, 2014.
- Lustgarten, Daniel L et al, Cryothermal Ablation: Mechanism of Tissue Injury and Current Experience in the Treatment of Tachyarrhythmias, *Progress in Cardiovascular Diseases*, vol. 41, No. 6 (May/June), 1999: pp. 481-498.
- Mahfoud, Felix et al, Expert Consensus Document from the European Society of Cardiology on Catheter-Based Renal Denervation, *European Heart Journal*, Apr. 25, 2013; 34(28):2149-57.
- Mancia, Giuseppe et al, Sympathetic Activation in the Pathogenesis of Hypertension and Progression of Organ Damage, *Hypertension Journal of The American Heart Association*, 1999, 34:724-728.
- McGahan, John P. et al, History of Ablation, *Tumor Ablation*, 2005, pp. 3-16.
- Medtronic, Inc., J.P. Morgan Healthcare Conference, Corrected Transcript, Jan. 13, 2014, Factset:Callstreet, www.callstreet.com.
- Medtronic, Inc., Medtronic Announces U.S. Renal Denervation Pivotal Trial Fails to Meet Primary Efficacy Endpoint While Meeting Primary Safety Endpoint, www.medtronic.com, Jan. 9, 2014.
- Medtronic, Inc., RDN Therapy with the Symplicity Renal Denervation System, Procedure Fact Sheet, www.medtronic.com, 2011.
- Medtronic, Inc., Renal Denervation (RON) Novel Catheter-based Treatment for Hypertension, Symplicity RON System Common Q&A, 2011.
- Medtronic, Inc., Scientific Basis Behind Renal Denervation for the Control of Hypertension, Dec. 2012, [http://www.icimeeting.com/2012/images/stories/PDF/1448\\_Wilcox\\_I\\_Mon.pdf](http://www.icimeeting.com/2012/images/stories/PDF/1448_Wilcox_I_Mon.pdf).
- Mehdi Rad, Ali et al, Temperature Controlled RF Ablation in Canine Ventricle and Coronary Sinus using 7 Fr or 5 Fr Ablation Electrodes, *PACE*, vol. 21, Jan. 1998, Part 11, 316-321.
- Meredith, It et al, Exercise Training Lowers Resting Renal But Not Cardiac Sympathetic Activity in Humans; *Hypertension Journal of The American Heart Association*, 1991;18:575-582.
- Michaelis, Lawrence L. et al, Effects of Renal Denervation and Renin Depletion on the Renal Responses to Intravascular Volume Expansion, *Ann Surg*. Mar. 1972; 175(3): 424-430.
- Millard, F.C. et al, Renal Embolization for Ablation of Function in Renal Failure and Hypertension, *Postgraduate Medical Journal* (1989) 65, 729-734.
- Dibona, Gerald F., Renal Innervation and Denervation: Lessons from Renal Transplantation Reconsidered, *Artificial Organs*, vol. 11, No. 6, 1987, 457-462.
- Dibona, Gerald F., Role of the Renal Nerves in Renal Sodium Retention and Edema Formation, *Trans Am Clin Climatol Assoc*. 1990; 101: 38-45.
- Dibona, Gerald F., Sympathetic Nervous System and Hypertension, *Hypertension Journal of The American Heart Association*, Jan. 28, 2013; 61: 556-560.
- Dibona, Gerald F., Sympathetic Nervous System and the Kidney in Hypertension, *Curr Opin Nephrol Hypertens*. Mar. 2002;11(2):197-200.
- Dibona, Gerald F., The Sympathetic Nervous System and Hypertension, *Hypertension Journal of The American Heart Association*, Vol. 43, Feb. 2004, 147-150.
- Doumas, Michael et al, Interventional Management of Resistant Hypertension, *The Lancet*, vol. 373, Apr. 11, 2009, pp. 1228-1230.
- Dubuc, Marc et al, Feasibility of Cardiac Cryoablation Using a Transvenous Steerable Electrode Catheter, *Journal of Interventional Cardiac Electrophysiology*, 1998, 2: 285-292.
- Elmula, Fadl et al, Renal Sympathetic Denervation in Patients With Treatment-Resistant Hypertension After Witnessed Intake of Medication Before Qualifying Ambulatory Blood Pressure, *Hypertension* Jul. 8, 2013;62:526-532.
- Esler, M. et al, Sympathetic Nerve Activity and Neurotransmitter Release in Humans: Translation from Pathophysiology into Clinical Practice, *Scandinavian Physiological Society*, 2003, 177, 275-284.
- Esler, Murray D. et al, Renal Sympathetic Denervation in Patients with Treatment-Resistant Hypertension (The Symplicity HTN-2 Trial): A Randomised Controlled Trial, *Lancet*, 2010; 376:1903-1909.
- Esler, Murray et al, Assessment of Human Sympathetic Nervous System Activity from Measurements of Norepinephrine Turnover, *Hypertension Journal of The American Heart Association*, vol. 11, No. 1, Jan. 1988, 3-20.
- Evelyn, Kenneth A. et al, Effect of Thoracolumbar Sympathectomy on the Clinical Course of Primary (Essential) Hypertension, *American Journal of Medicine*, Feb. 1960, 188-221.
- Freyberg, RH\_ et al, The Effect on the Kidney of Bilateral Splanchnicectomy in Patients with Hypertension, *The Journal of Clinical Investigation*, vol. 16, Issue 1, Jan. 1937, 49-65.
- Gafoor, Sameer et al, Nonresponders to Renal Denervation for Resistant Hypertension, *Endovascular Today*, Oct. 2013, 63-70.
- Garel, L et al, Fatal Outcome After Ethanol Renal Ablation in Child with End-Stage Kidneys; *AJR* 146:593-594, Mar. 1986.
- Gazdar, A. F. et al, Neural Degeneration and Regeneration in Human Renal Transplants, *The New England Journal of Medicine*, vol. 238, No. 5, Jul. 1970, 222-224.
- Goldberg, Michael R et al, Reconstructive Vascular Surgery for Renovascular Hypertension, *Can Med Assoc J*\_Feb. 2, 1974;110(3):275-80.
- Golwyn, Daniel H\_ et al, Percutaneous Transcatheter Renal Ablation with Absolute Ethanol for Uncontrolled Hypertension or Nephrotic Syndrome: Results in 11 Patients with End-Stage Renal Disease, *Journal of Vascular and Interventional Radiology*, Jul. Aug. 1997; vol. 8, No. 4, 527-533.
- Gorisch, Wolfram et al, Heat-Induced Contraction of Blood Vessels, *Lasers in Surgery and Medicine* 2:1-13 (1982).
- Grassi, Guido et al, Baroreflex Control of Sympathetic Nerve Activity in Essential and Secondary Hypertension, *Hypertension Journal of The American Heart Association*, 1998;31:68-72.
- Grassi, Guido et al, Dissociation Between Muscle and Skin Sympathetic Nerve Activity in Essential Hypertension, Obesity, and Congestive Heart Failure, *Hypertension*. 1998;31:64-67.
- Grimson, Keith S. et al, Results of Treatment of Patients with Hypertension by Total Thoracic and Partial to Total Lumbar Sympathectomy, Splanchnicectomy and Celiac Ganglionectomy, *Annals of Surgery*, Jun. 1949, vol. 129, No. 6, 850-871.
- Grimson, Keith S. et al, Total Thoracic and Partial to Total Lumbar Sympathectomy, Splanchnicectomy and Celiac Ganglionectomy for Hypertension, *Annals of Surgery*, Oct. 1953, vol. 138, No. 4, 532-547.
- Grimson, Keith S., Total Thoracic and Partial to Total Lumbar Sympathectomy and Celiac Ganglionectomy in the Irratment of Hypertension, *Annals of Surgery*, Oct. 1941, vol. 114, No. 4, 753-775.
- Guyton, Arthur C., Blood Pressure Control Special Role of the Kidneys and Body Fluids, *Science*, vol. 252, Jun. 1991, 1813-1816.
- Hafkenschiel, Joseph H. et al, Primary Hypertension Survey of the Survival of Patients with Established Diastolic Hypertension After Ten Years of Medical and Surgical Treatment, *The American Journal of Cardiology*, vol. 16, Jul. 1965, 61-66.
- Hafkenschiel, Joseph H. et al, The Surgical Treatment of Hypertension with Particular Reference to Adrenalectomy and Sympathectomy, *Transactions. American College of Cardiology*, vol. 5, Dec. 1955, pp. 107-112.

(56)

## References Cited

## OTHER PUBLICATIONS

- Hall, J.E. et al, Role of Sympathetic Nervous System and Neuropeptides in Obesity Hypertension, *Brazilian Journal of Medical and Biological Research*, 2000, 33:605-618.
- Hall, John E., The Kidney, Hypertension, and Obesity, *Hypertension*. 2003;41:625-633.
- Hall, Winthrop H. et al, Combined Embolization and Percutaneous Radiofrequency Ablation of a Solid Renal Tumor, *American Journal of Roentgenology*, 174, Jun. 2000, 1592-1594.
- Hamm, Christian et al, *Confluence*, Issue eight, Apr. 2014.
- Han, Young-Min et al, Renal Artery Embolization with Diluted Hot Contrast Medium: An Experimental Study, *Journal of Vascular and Interventional Radiology*, Jul. 2001;12(7):862-868.
- Hansen, Jesper Melchoir et al, The Transplanted Human Kidney Does Not Achieve Functional Reinnervation, *Clinical Science*, (1994) 87, 13-20.
- Heuer, George J., The Surgical Treatment of Essential Hypertension, *Annals of Surgery*, Oct. 1936, vol. 104, No. 3, 771-786.
- Hinton, J. William, End Results of Thoracolumbar Sympathectomy for Advanced Essential Hypertension, *The Bulletin*, Apr. 1948, 239-252.
- Holmer, Stephan et al, Role of Renal Nerves for the Expression of Renin in Adult Rat Kidney, *The American Journal of Physiology*, May 1994;266(5 Pt 2):F738-F745.
- Hoobler, S.W. et al, The Effects of Splanchnicectomy on the Blood Pressure in Hypertension, *Circulation Journal of The American Heart Association*, vol. IV, Aug. 1951, 173-183.
- Hoppe, Uta C. et al, Minimally Invasive System for Baroreflex Activation Therapy Chronically Lowers Blood Pressure With Pacer-maker-like Safety Profile: Results from the Barostim Neo Ttrial, *J Am Soc Hypertens*. Jul.-Aug. 2012;6(4):270-6.
- Howard, James P. et al, Size of Blood Pressure Reduction from Renal Denervation: Insights from Meta-Analysis of Antihypertensive Drug Trials of 4121 Patients with Focus on Trial Design: the Converge Report, *Heart*, Sep. 15, 2013; 0:1-9.
- Howard, James P. et al, Unintentional Overestimation of an Expected Antihypertensive Effect in Drug and Device Trials: Mechanisms and Solutions, *International Journal of Cardiology*, vol. 172, Issue 1, Mar. 1, 2014, pp. 29-35.
- Howell, Marcus H. et al, Tandem Stenting of Crossed Renal Arteries with Ostial Stenosis, *Tex Heart Inst J*. 2000; 27(2): 166-169.
- Hoye, Neil A. et al, Endovascular Renal Denervation: A Novel Sympatholytic with Relevance to Chronic Kidney Disease, *Clinical Kidney Journal Advance Access*, Nov. 8, 2013; O: 1-8.
- Huang, Shoeni K. Stephen et al, Radiofrequency Catheter Ablation of Cardiac Arrhythmias, *Basic Concepts and Clinical Applications*, Wiley-Blackwell, Jun. 2000, 1-12.
- Huang, Wann-Chu, Renal Denervation Prevents and Reverses Hyperinsulinemia-Induced Hypertension in Rats, *Hypertension Journal of The American Heart Association*, 1998;32:249-254.
- Humphreys, Michael H., Renal Nerves and CKD: Is Renal Denervation the Answer?, *Journal of The American Society of Nephrology*, 2012, 23: 1-3.
- International Search Report and Written Opinion for Application No. PCT/US2010/054637 dated Jan. 3, 2011.
- International Search Report and Written Opinion for Application No. PCT/US2010/054684 dated Jan. 10, 2011.
- Irigoyen, M.C.C. et al, Baroreflex Control of Sympathetic Activity in Experimental Hypertension, *Brazilian Journal of Medical and Biological Research*, {1998} 31: 1213-1220.
- Izzo, Jr, Joseph L et al, The Sympathetic Nervous System and Baroreflexes in Hypertension and Hypotension, *Current Hypertension Reports* 1999, 3:254-263.
- Jackman, Warren M. et al, Catheter Ablation of Arrhythmias, Proposed Anatomy and Catheter Ablation of Epicardial Posteroseptal and Left Posterior Accessory AV Pathways (Chapter 16), 2002, Futura Publishing Company, Inc., 321-343.
- Abboud, Francois M., The Sympathetic System in Hypertension, *Slate-of-the-Art Review, Hypertension Journal of The American Heart Association, Hypertension* 4 (suppl II): 11-208-11-225, 1982.
- Allen, Edgar V., Sympathectomy for Essential Hypertension, *Circulation Journal of the American Heart Association*, vol. VI, Jul. 1952, 131-140.
- Anderson, Erling A. et al, Elevated Sympathetic Nerve Activity in Borderline Hypertensive Humans, Evidence From Direct Intra-neural Recordings, *Hypertension Journal of the American Heart Association*, vol. 14, No. 2, Aug. 1989, 177-183.
- Ardian, Inc., Ardian(R) Receives 2010 EuroPCR Innovation Award and Demonstrates Further Durability of Renal Denervation Treatment for Hypertension, *PR Newswire*, Jun. 3, 2010.
- Arentz, Thomas et al, Feasibility and Safety of Pulmonary Vein Isolation Using a New Mapping and Navigation System in Patients with Refractory Atrial Fibrillation, *Circulation Journal of the American Heart Association*, Nov. 18, 2003, 2484-2490.
- Badoer, Emilio et al, Cardiac Afferents Play the Dominant Role in Renal Nerve Inhibition Elicited by Volume Expansion in the Rabbit, *American Journal of Physiology*, 1998, R383-R388.
- Bakris, George L. et al, Baroreflex Activation Therapy Provides Durable Benefit in Patients with Resistant Hypertension: Results of Long-Term Follow-up in the Rheas Pivotal Trial, *J Am Soc Hypertens*. Mar.-Apr. 2012;6(2):152-8.
- Bao, Gang et al, Blood Pressure Response to Chronic Episodic Hypoxia: Role of the Sympathetic Nervous System, *American Journal of Physiology*, 1997, 95-101.
- Barajas, Luciano et al, Anatomy of the Renal Innervation: Intrarenal Aspects and Ganglia of Origin, *Canadian Journal of Physiology and Pharmacology*, vol. 70, No. 5, May 1992, 735-749.
- Barajas, Luciano et al, Monoaminergic Innervation of the Rat Kidney: A Quantitative Study, *American Journal of Physiology*, vol. 259, No. 3, Sep. 1990, F503-F511.
- Bardram, Linda et al, Late Results After Surgical Treatment of Renovascular Hypertension, A Follow-up Study of 122 Patients 2-18 Years After Surgery, *Annals of Surgery*, vol. 201, No. 2, Feb. 1985, 219-224.
- Bello-Reuss, Elsa et al, Effect of Renal Sympathetic Nerve Stimulation on Proximal Water and Sodium Reabsorption, *The Journal of Clinical Investigation*, vol. 57, Apr. 1976, 1104-1107.
- Bello-Reuss, Elsa et al, Effects of Acute Unilateral Renal Denervation in the Rat, *The Journal of Clinical Investigation*, vol. 56, Jul. 1975, 208-217.
- Benito, Fernando et al, Radiofrequency Catheter Ablation of Accessory Pathways in Infants, *Heart*, 1997, 78, 160-162.
- Bernardi, Luciano et al, Influence of Type of Surgery on the Occurrence of Parasympathetic Reinnervation After Cardiac Transplantation, *Circulation Journal of The American Heart Association*, Apr. 14, 1998;97(14):1368-74.
- Bertog, Stefan C. et al, Renal Denervation for Hypertension, *JACC: Cardiovascular Interventions*, vol. 5, No. 3, Mar. 2012, 249-258.
- Bertram, Harald et al, Coronary Artery Stenosis After Radiofrequency Catheter Ablation of Accessory Atrioventricular Pathways in Children with Ebstein's Malformation, *Circulation Journal of the American Heart Association*, 2001, 538-543.
- Blankestijn, Peter J. et al, Renal Denervation: Potential Impact on Hypertension in Kidney Disease?, *Nephrol Dial Transplant* (2011) O: 1-3.
- Blankestijn, Peter J. et al, Sympathetic Overactivity in Renal Failure Controlled by ACE Inhibition: Clinical Significance, *Nephrol Dial Transplant*, 2000, 15, 755-758.
- Blum, Ulrich et al, Treatment of Ostial Renal-Artery Stenoses with Vascular Endoprostheses After Unsuccessful Balloon Angioplasty, *The New England Journal of Medicine*, vol. 336, No. 7, Feb. 1997, 459-465.
- Brinkmann, Julia et al, Catheter-Based Renal Nerve Ablation and Centrally Generated Sympathetic Activity in Difficult-to-Control Hypertensive Patients Prospective Case Series, *Hypertension*. 2012;60:1485-1490.
- Brookes, Linda et al, Renal Denervation: Is Reality Meeting Expectations?, An Interview with Michel Azizi, MD, PhD, *Medscape*, Jan. 7, 2013.
- Bunte, Matthew C. et al, Endovascular Treatment of Resistant and Uncontrolled Hypertension, *JACC: Cardiovascular Interventions*, vol. 6, No. 1, Jan. 2013, 1-9.

(56)

**References Cited**

## OTHER PUBLICATIONS

Calleary, Hickey D. et al, Pre-Transplant Bilateral Native Nephrectomy for Medically Refractory Hypertension, *The Irish Medical Journal*, Jul.-Aug. 2001;94(7):214-6.

Callens, David J. et al, Narrowing of the Superior Vena Cava-Right Atrium Junction During Radiofrequency Catheter Ablation for Inappropriate Sinus Tachycardia: Analysis with Intracardiac Echocardiography, *Journal of the American College of Cardiology*, vol. 33, No. 6, 1999, 1667-1670.

Campese, V.M., Is Hypertension in Chronic Renal Failure Neurogenic in Nature?, *Nephrol Dial Transplant*, 1994, 9:741-742.

Campese, Vito M. et al, Neurogenic Factors in Renal Hypertension, *Current Hypertension Reports*, 2002 4: 256-260.

Campese, Vito M\_ et al, Renal Afferent Denervation Prevents Hypertension in Rats With Chronic Renal Failure, *Hypertension*, 1995, 25, 878-882.

Campese, Vito M\_ et al, Renal Afferent Denervation Prevents the Progression of Renal Disease in the Renal Ablation Model of Chronic Renal Failure in Rat, *American Journal of Kidney Disease*, vol. 26, No. 5, Nov. 1995, 861-865.

Campese, Vito M., Interventional Hypertension: A New Hope or a New Hype? The Need to Redefine Resistant Hypertension, *J Hypertens*. Nov. 2013; 31 (11 ):2118-21.

Canadian Agency for Drugs and Technologies in Health, Catheter-Based Renal Denervation for Wreatment-Resistant Hypertension; Issues in Emerging Health Technologies, Issue 121, Mar. 2013.

Carlstedt, Thomas et al, Regrowth of Lesioned Dorsal Root Nerve Fibers into the Spinal Cord of Neonatal Rats, *Neuroscience Letters* Feb. 10, 1987;74(1):14-8.

Chabanier, H\_ et al, On the Decapsulation and Neurectomy of the Kidney in Permanent Hypertensive States, *The Medical Press*, Feb. 22, 1936, No. 16, 307-310.

Cicccone, C D et al, Effects of Acute Renal Denervation on Kidney Function in Deoxycorticosterone Acetate-Hypertensive Swine, *Hypertension Journal of the American Heart Association*, Oct. 1986, vol. 8, No. 10, 925-931.

Ciriello, John et al, Renal Afferents and Hypertension, *Current Hypertension Reports* 2002, 4:136-142.

Converse, Richard L. et al, Sympathetic Overactivity in Patients with Chronic Renal Failure, *The New England Journal of Medicine*, vol. 327, No. 27, 1992, 1912-1918.

Crile, George, The Clinical Results of Celiac Ganglionectomy in the Treatment of Essential Hypertension, *Annals of Surgery*, Jun. 1938; 107(6): 909-916.

Cruickshank, J.M., Beta-Blockers Continue to Surprise Us, *European Heart Journal* (2000) 21, 354-364.

Curtis, John J\_ et al, Surgical Therapy for Persistent Hypertension After Renal Transplantation, *Transplantation*, vol. 31, No. 2, 1981, 125-128.

Dailey, U.G., Surgical Treatment of Hypertension: A Review—Part 11, *Journal of the National Medical Association*, May 1948, vol. 40, No. 3., 113-116.

Dailey, U.G., Surgical Treatment of Hypertension: A Review—Part 111, *Journal of the National Medical Association*, Jul. 1948, vol. 40, No. 4, 160-162.

Dailey, U.G., The Surgical Treatment Of Hypertension: A Review, *Journal of the National Medical Association*, Mar. 1948, vol. 40, No. 2, 76-79.

Davis, Mark I. et al, Effectiveness of Renal Denervation Therapy for Resistant Hypertension A Systematic Review and Meta-Analysis, *Journal of the American College of Cardiology*, vol. 62, No. 3, Jul. 16, 2013, 231-241.

De Wardener, H.E., The Hypothalamus and Hypertension, *Physiological Reviews*, vol. 81, No. 4, Oct. 2001.

Dequattro V\_ et al, The Sympathetic Nervous System: The Muse of Primary Hypertension, *Journal of Human Hypertension*, 2002, 16 (Suppl 1 ), S64-S69.

Dibona, Gerald F. et al, Neural Control of Renal Function, *Physiological Reviews*, vol. 77, No. 1, Jan. 1997, 175-197.

Dibona, Gerald F. et al, Translational Medicine: The Antihypertensive Effect of Renal Denervation, *America! Journal of Physiology*, 2010, 298, R245-R253.

Dibona, Gerald F., Neural Control of Renal Function: Cardiovascular Implications, *Hypertension Journal of The American Heart Association*, vol. 13, No. 6, Part 1, Jun. 1989, 539-548.

Dibona, Gerald F., Neural Control of the Kidney: Functionally Specific Renal Sympathetic Nerve Fibers, *American Journal of Physiology*, 2000, 279, R1517-R1524.

Dibona, Gerald F., Neural Control of the Kidney: Past, Present, and Future, *Hypertension Journal of The American Heart Association*, vol. 41, Mar. 2003, Part 11, 621-624.

Zazgornik, Jan et al, Bilateral Nephrectomy: The Best, but Often Overlooked, Treatment for Refractory Hypertension in Hemodialysis Patients, *AJH* 1998; 11:1364-1370.

\* cited by examiner



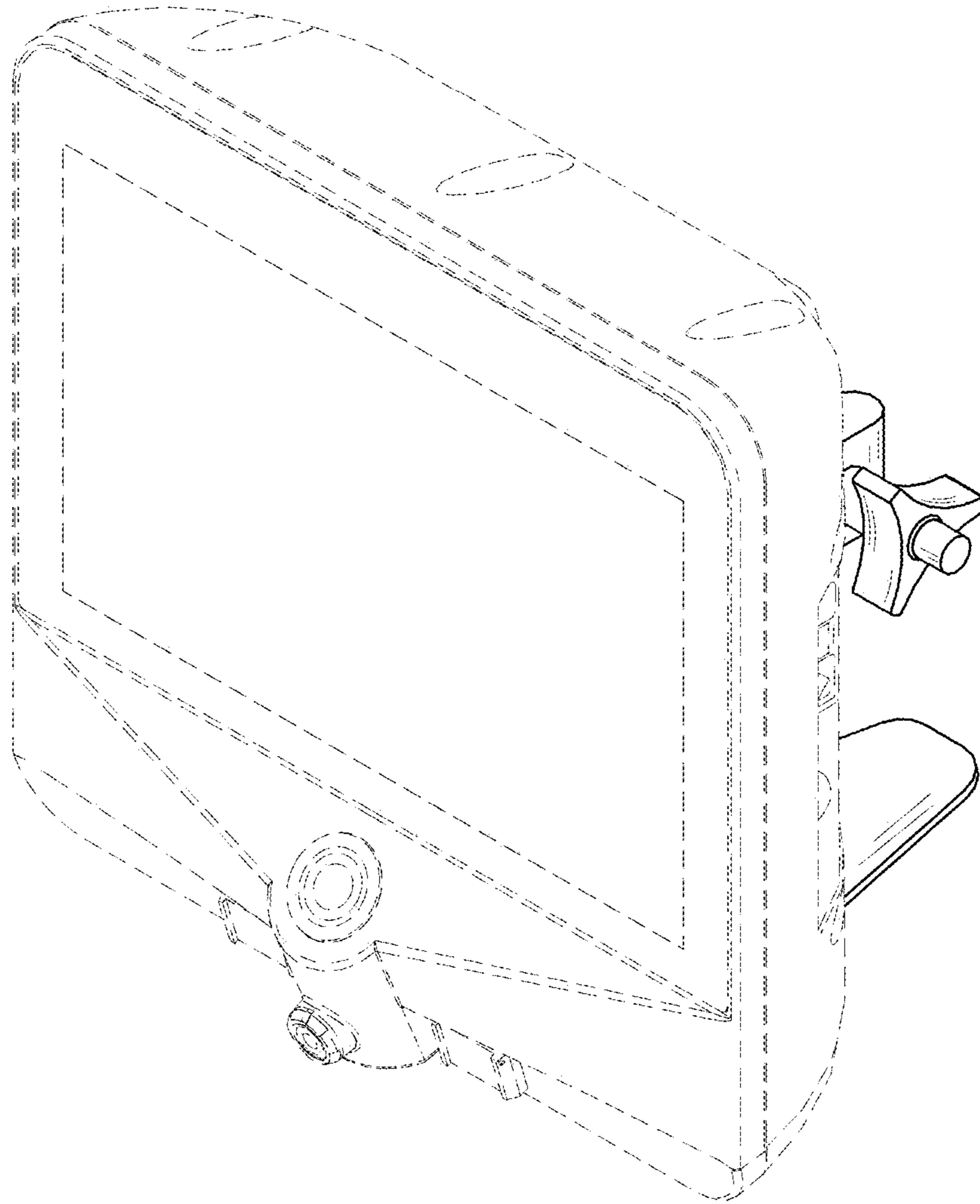

FIG. 1

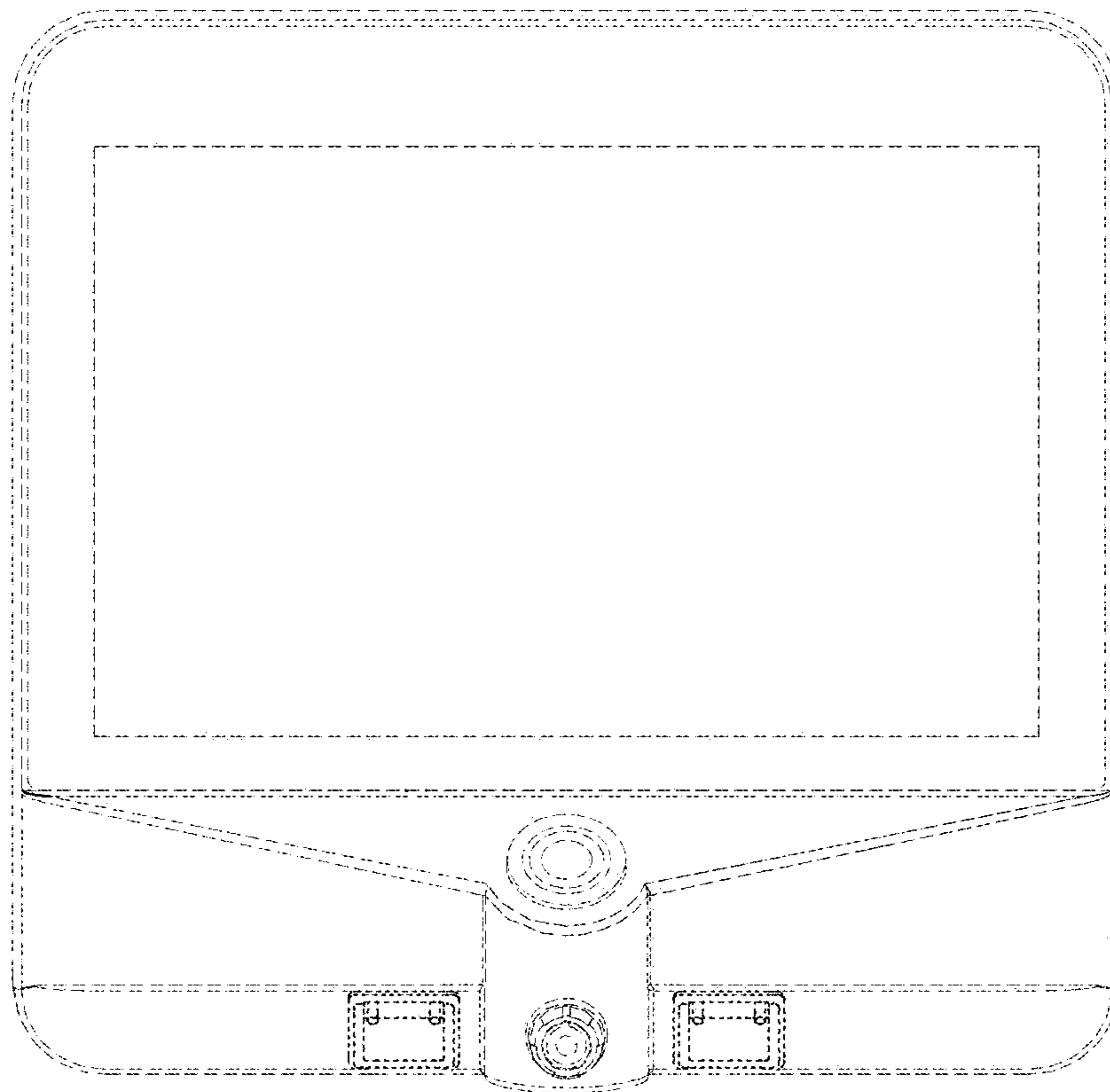

FIG. 2

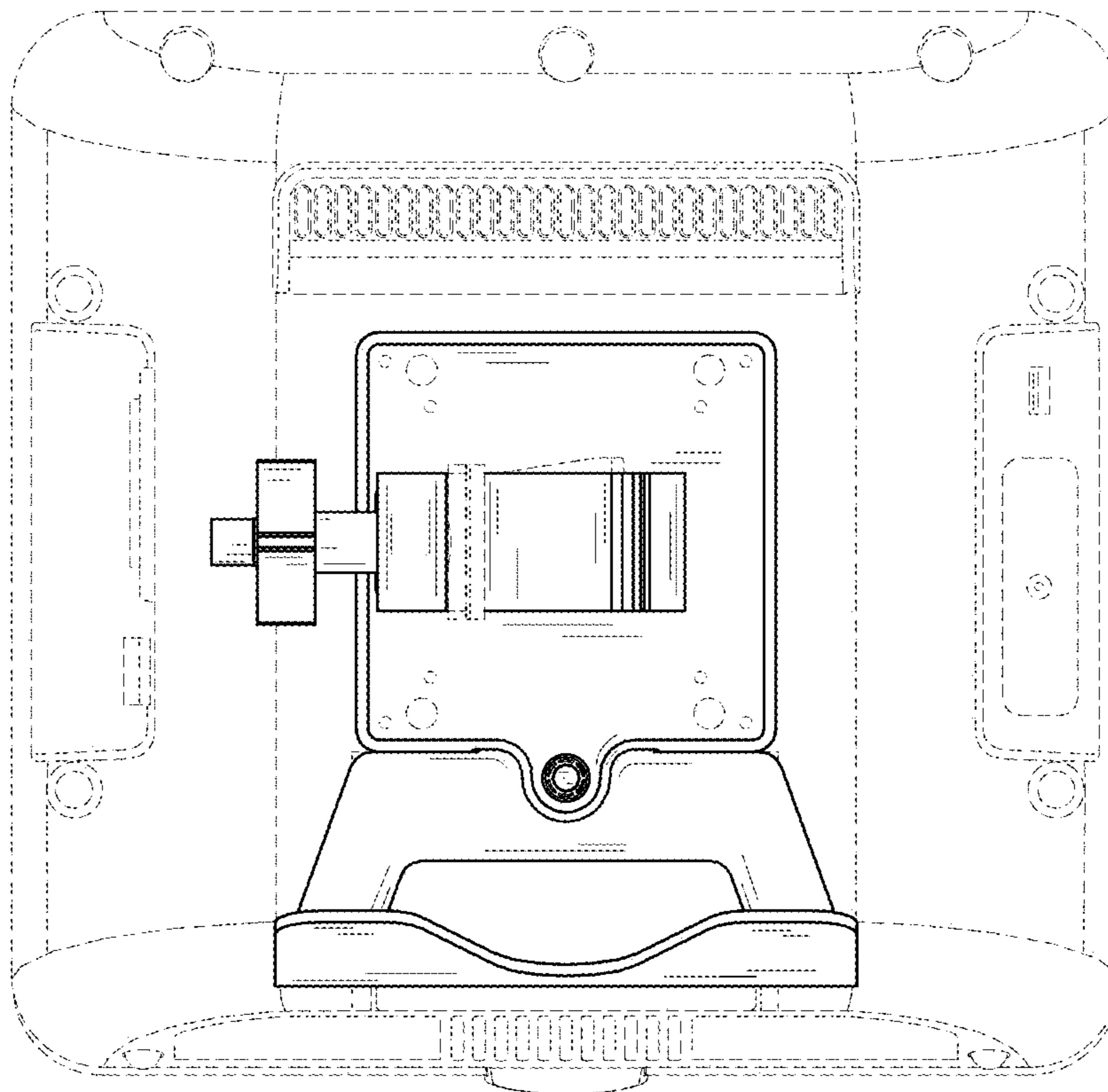

FIG. 3

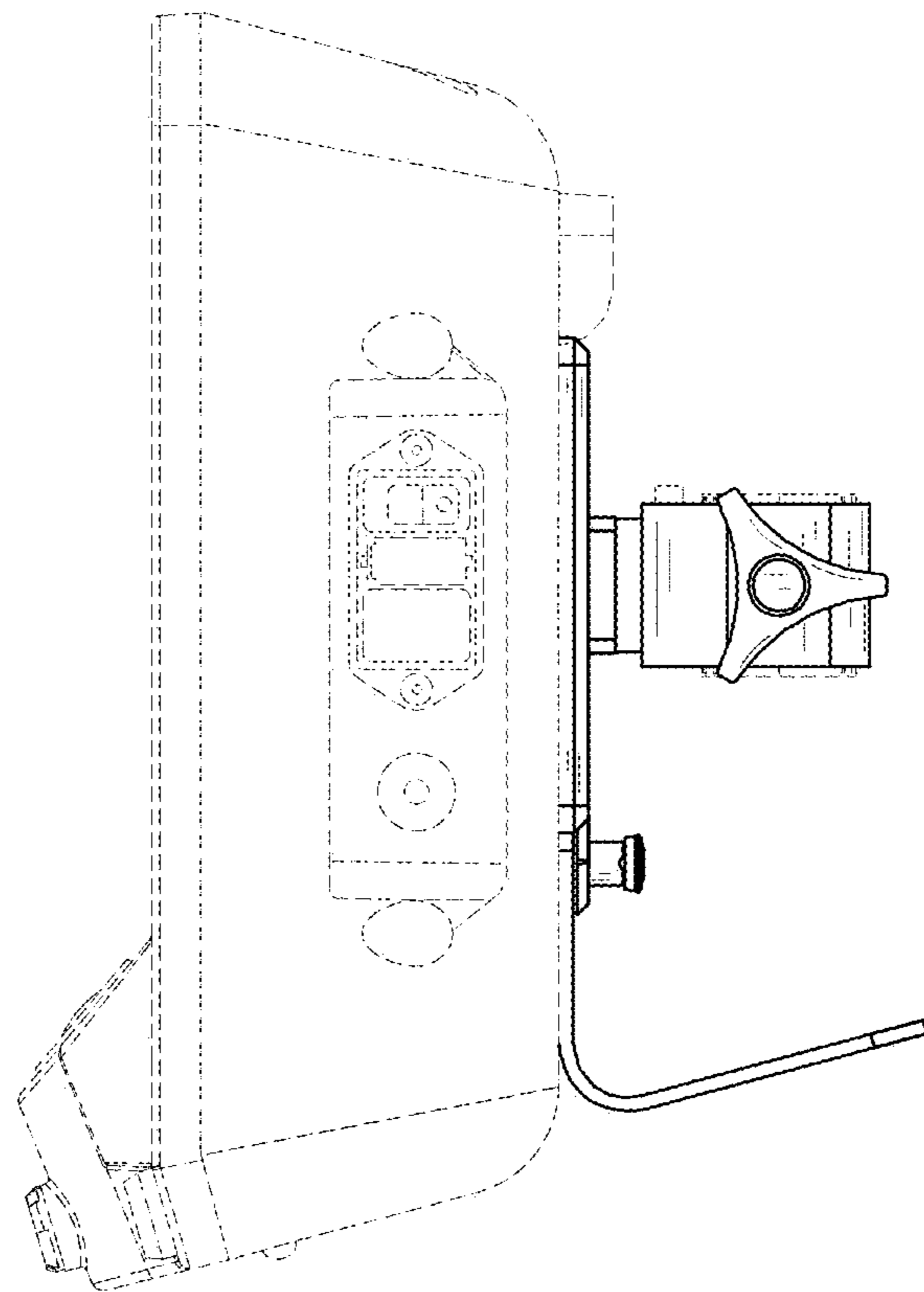

FIG. 4

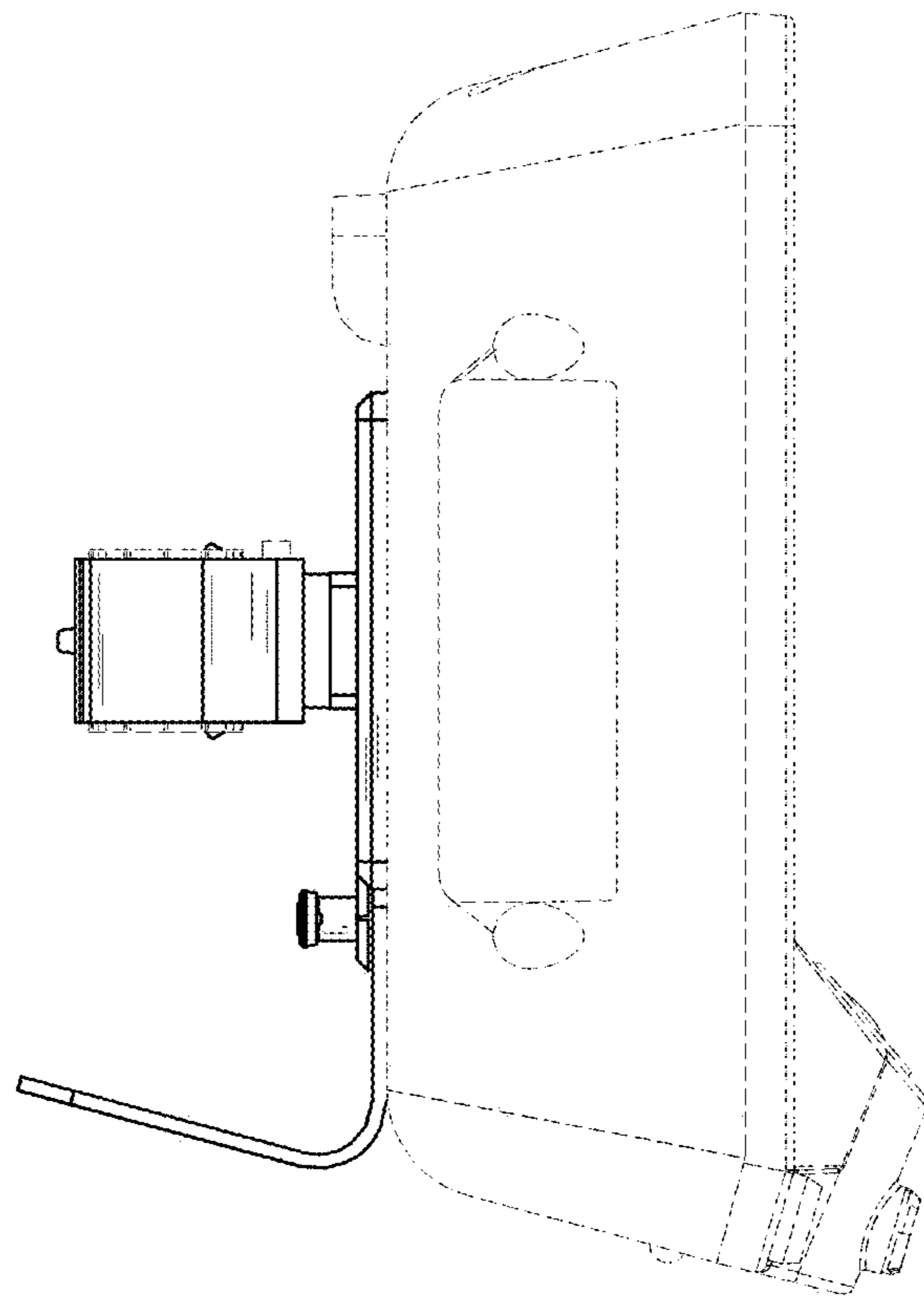

FIG. 5

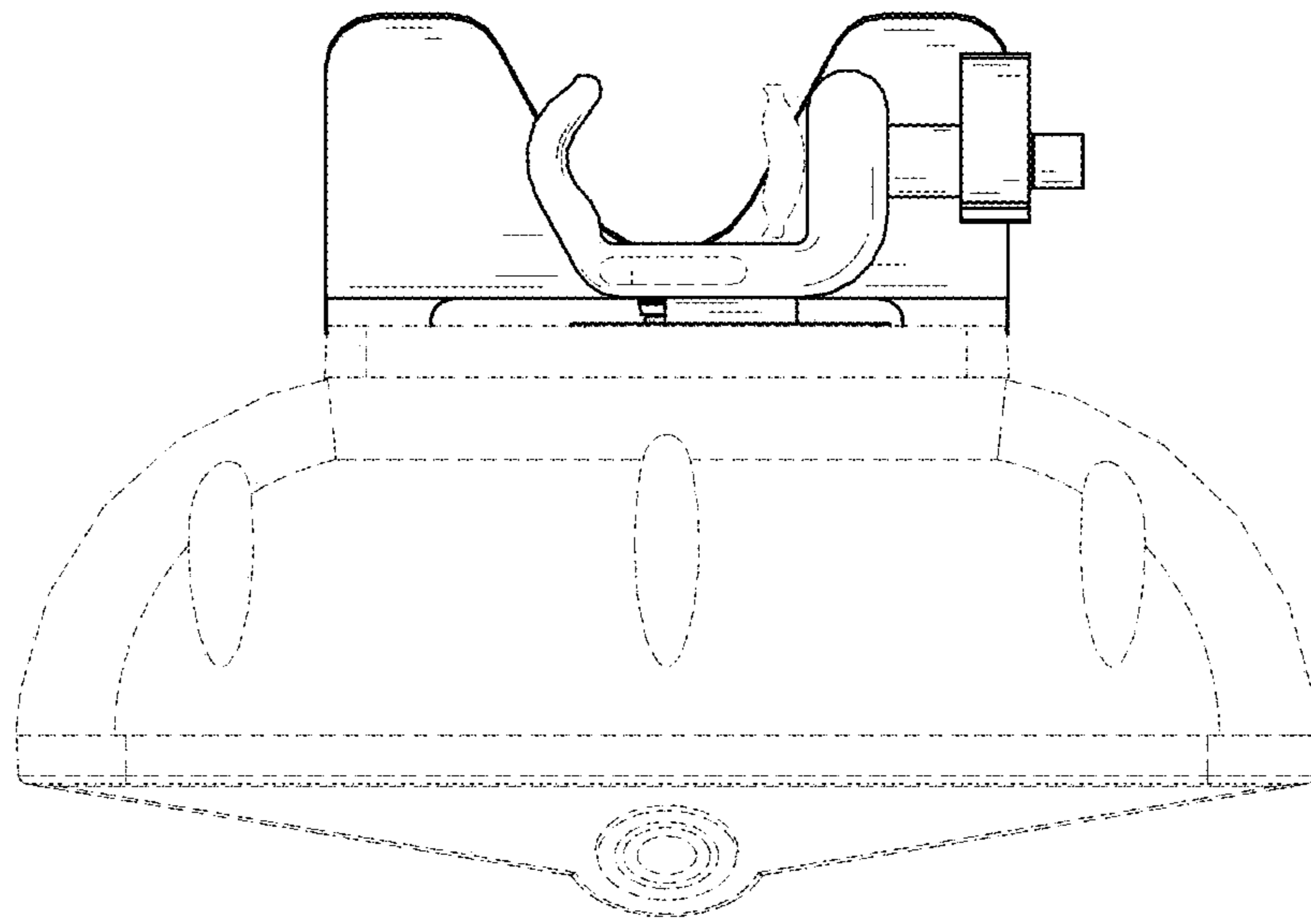

FIG. 6

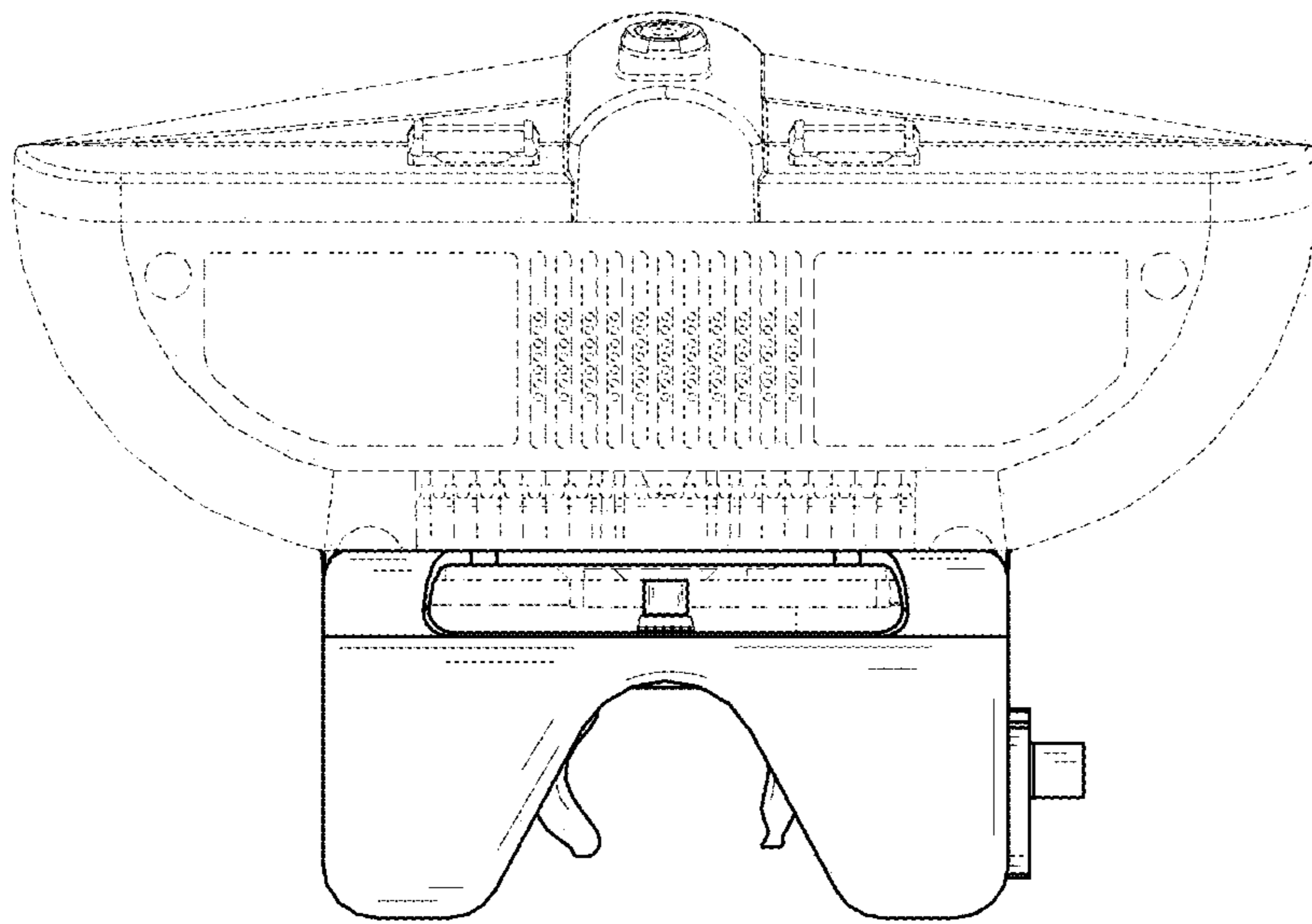

FIG. 7