



US00D986974S

(12) **United States Design Patent** (10) **Patent No.:** **US D986,974 S**
Chen (45) **Date of Patent:** **** May 23, 2023**

(54) **RACING SIMULATOR COCKPIT**

OTHER PUBLICATIONS

(71) Applicant: **Chusong Chen**, Guangdong Province (CN)

Guangzhou Diwang Electronic Commerce Co., Ltd. Reg. No. 6,483,610, Registered Sep. 14, 2021 Ser. No. 90-352,895, filed Dec. 2, 2020.

(72) Inventor: **Chusong Chen**, Guangdong Province (CN)

(Continued)

(**) Term: **15 Years**

Primary Examiner — Mehri F Bajoul

(21) Appl. No.: **29/871,520**

(57) **CLAIM**

The ornamental design for a racing simulator cockpit, as shown and described.

(22) Filed: **Feb. 22, 2023**

DESCRIPTION

(51) **LOC (14) Cl.** **21-01**

(52) **U.S. Cl.**
USPC **D21/326**

(58) **Field of Classification Search**
USPC D21/326, 329, 327, 333–336, 477;
D6/334–336, 338, 356, 364, 365, 366,
D6/367, 374, 716, 716.1, 716.4
CPC .. A47C 1/121; A47C 7/40; A47C 7/46; A47C
7/462; A47C 7/50; A47C 7/723; A63F
9/00; A63F 9/24; A63F 1/00; A63F 3/00;
G07F 17/3216; G09B 9/02
See application file for complete search history.

FIG. 1 is a front and top perspective view of a racing simulator cockpit, showing my new design;
FIG. 2 is a rear and bottom perspective view thereof;
FIG. 3 is a front elevation view thereof;
FIG. 4 is a rear elevation view thereof;
FIG. 5 is a left side elevation view thereof;
FIG. 6 is a right side elevation view thereof;
FIG. 7 is a top plan view thereof;
FIG. 8 is a bottom plan view thereof;
FIG. 9 is an enlarged perspective view of detail “9” identified in FIG. 1;
FIG. 10 is an enlarged perspective view of detail “10” identified in FIG. 1;
FIG. 11 is an enlarged perspective view of detail “11” identified in FIG. 1;
FIG. 12 is an enlarged perspective view of detail “12” identified in FIG. 1;
FIG. 13 is an enlarged perspective view of detail “13” identified in FIG. 1;
FIG. 14 is an enlarged perspective view of detail “14” identified in FIG. 2; and,
FIG. 15 is another perspective view thereof, shown in an alternative position.
The dashed lines in the figures illustrate portions of the racing simulator cockpit, that form no part of the claimed design. The dash dot dash lines in FIGS. 1, 2, 9, 10, 11, 12, 13 and 14 are for the purpose of illustrating the enlarged views indicators and form no part of the claimed design.

(56) **References Cited**

U.S. PATENT DOCUMENTS

D465,343 S *	11/2002	Daneault	D6/338
D545,912 S *	7/2007	Nunokawa	D21/326
D598,207 S *	8/2009	Smit	D6/335
D612,623 S *	3/2010	Smit	D6/366
D612,641 S *	3/2010	Smit	D6/366
D651,815 S *	1/2012	Smit	D6/336
D656,553 S *	3/2012	Blaskov	D21/333
D665,181 S *	8/2012	Crepeau	D6/356
D679,914 S *	4/2013	Smit	D6/338
D691,822 S *	10/2013	Smit	D6/368
D701,917 S *	4/2014	Ghahramanian	D21/333
D835,198 S *	12/2018	Berlinches	D21/326

(Continued)

1 Claim, 15 Drawing Sheets

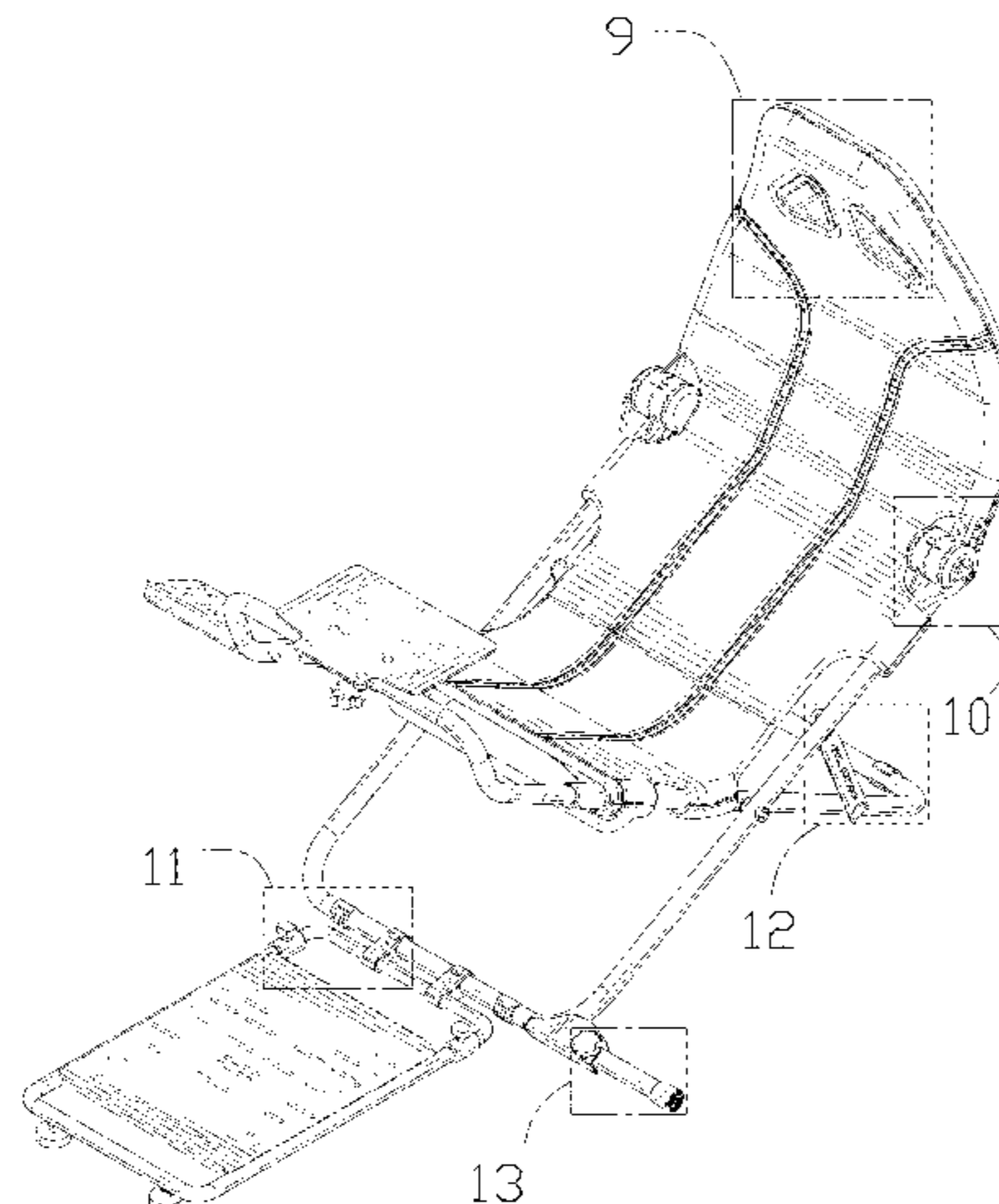

(56)

References Cited

U.S. PATENT DOCUMENTS

D856,020 S * 8/2019 Ghahramanian D6/367
10,653,242 B2 * 5/2020 Ortiz A47C 7/72
D885,779 S * 6/2020 Li D6/366
D910,758 S * 2/2021 Leong D21/326
D912,733 S * 3/2021 Ghahramanian D21/333
D930,081 S * 9/2021 Ghahramanian D21/326
D936,744 S * 11/2021 Singanallur Murali D21/333
D937,350 S * 11/2021 Ghahramanian D21/326
D971,334 S 11/2022 You
D974,475 S * 1/2023 Yan D21/333
D977,011 S * 1/2023 Xu D21/326

OTHER PUBLICATIONS

Senyu Technology Development (Guangzhou) Co., Ltd. U.S. Appl.
No. 97/329,730, filed Mar. 24, 2022.

* cited by examiner

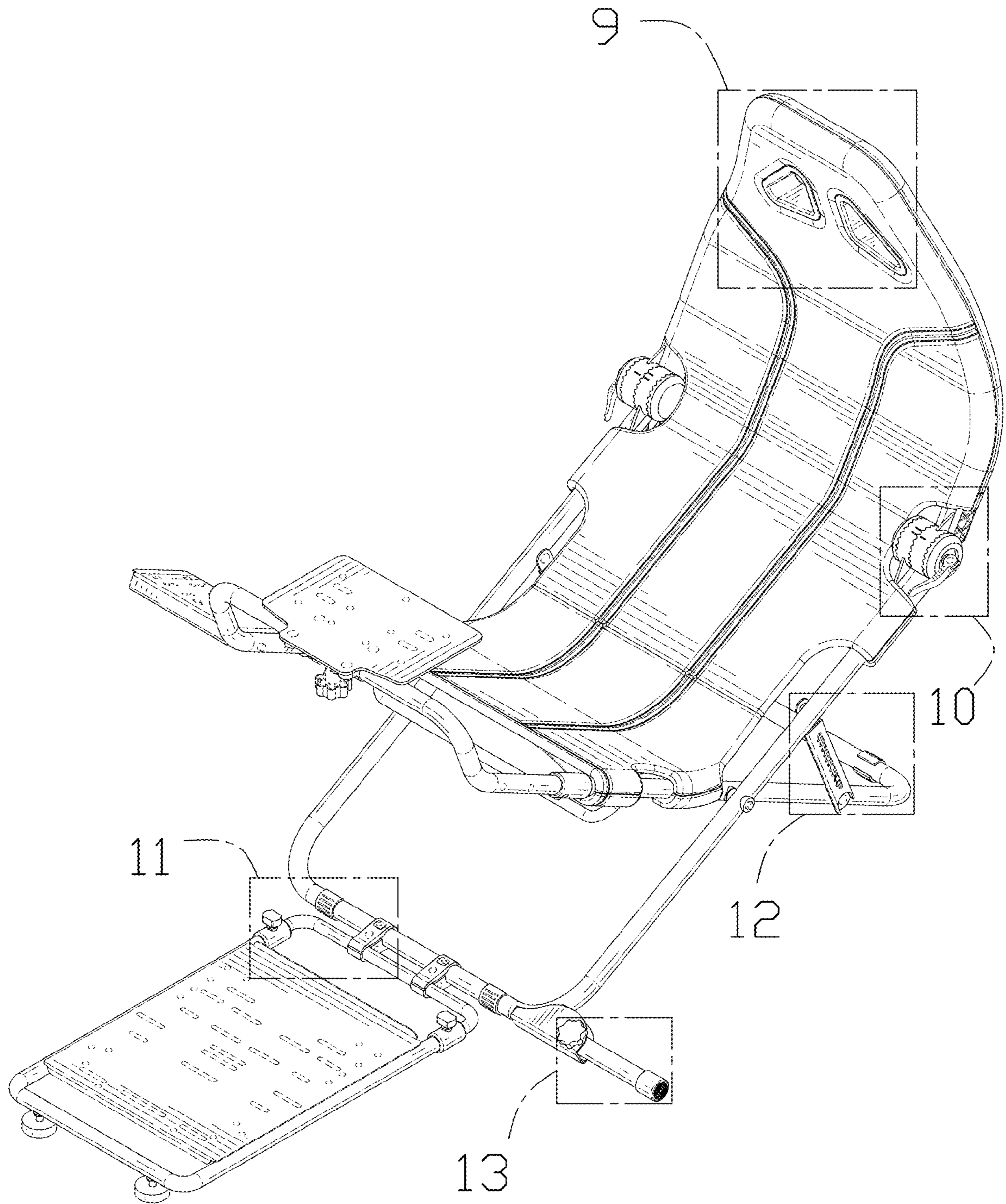

FIG. 1

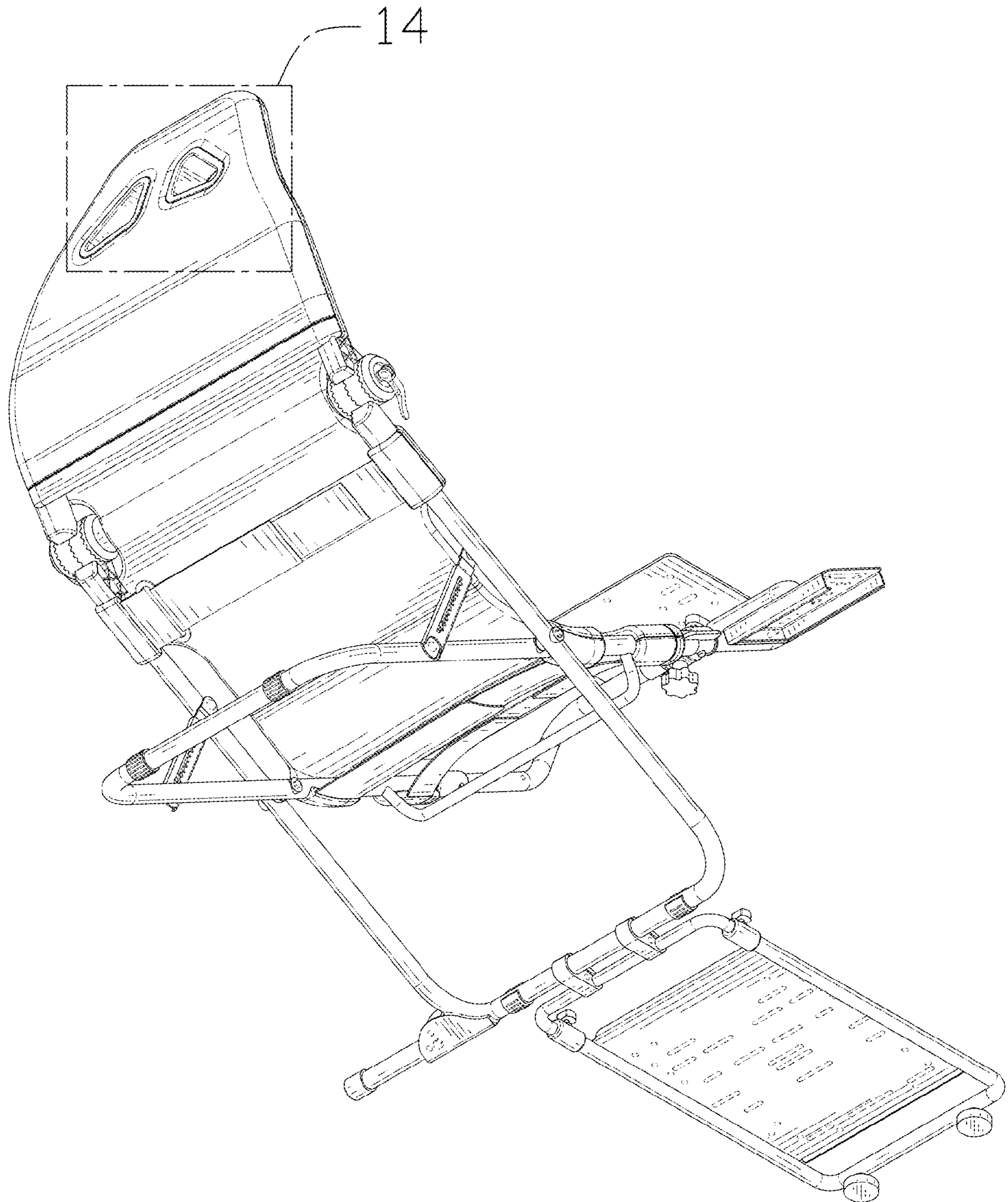

FIG. 2

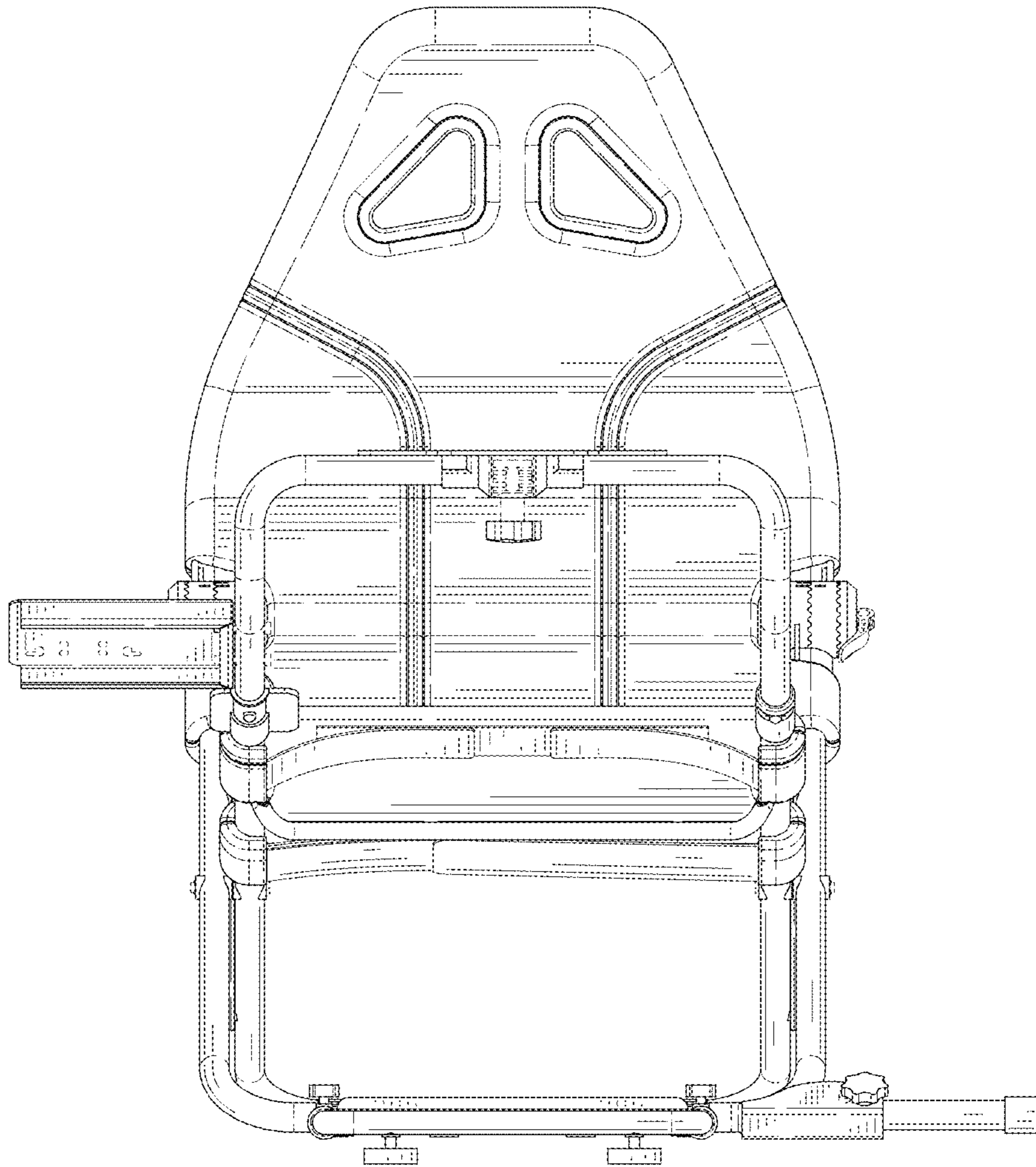

FIG. 3

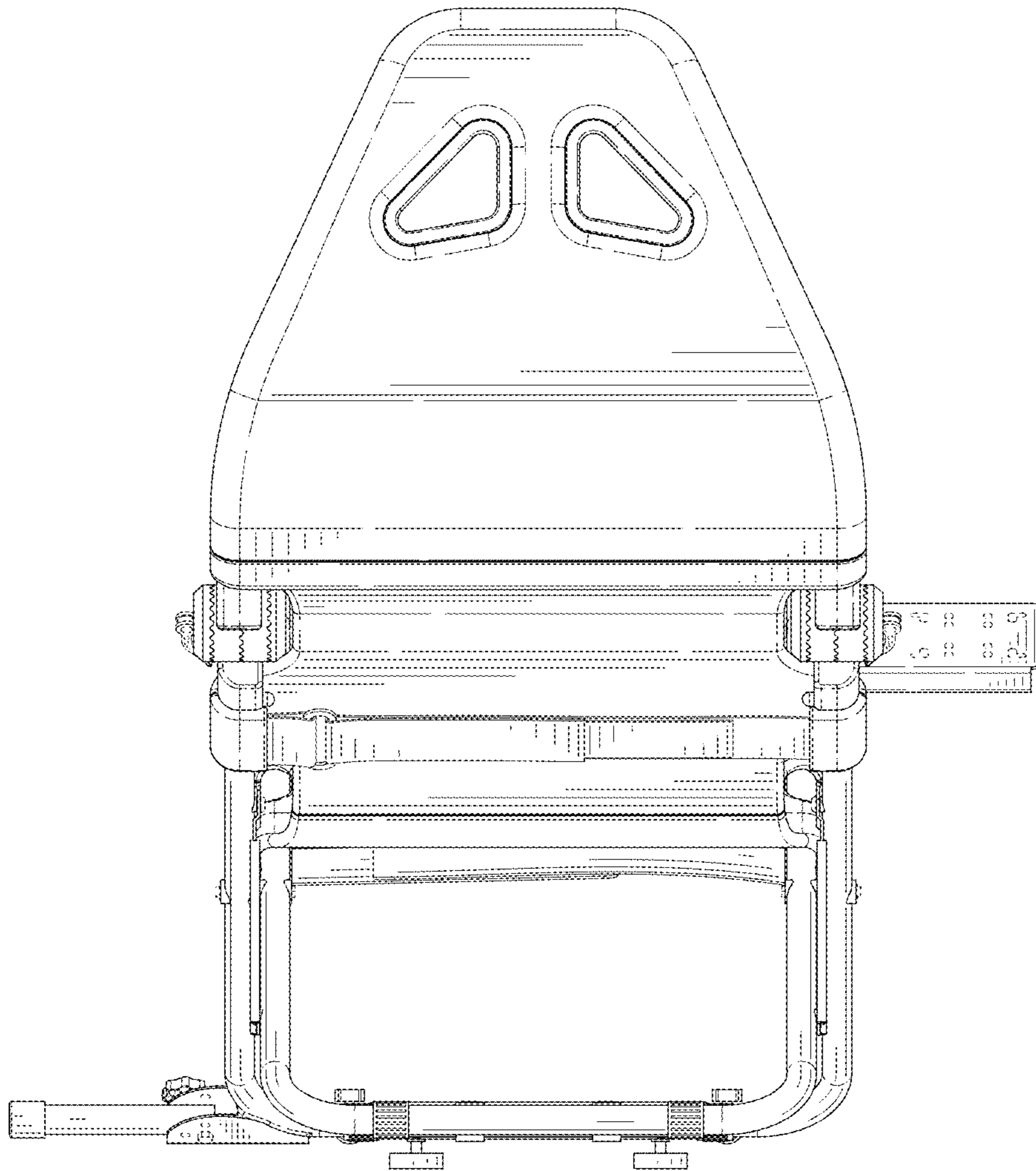

FIG. 4

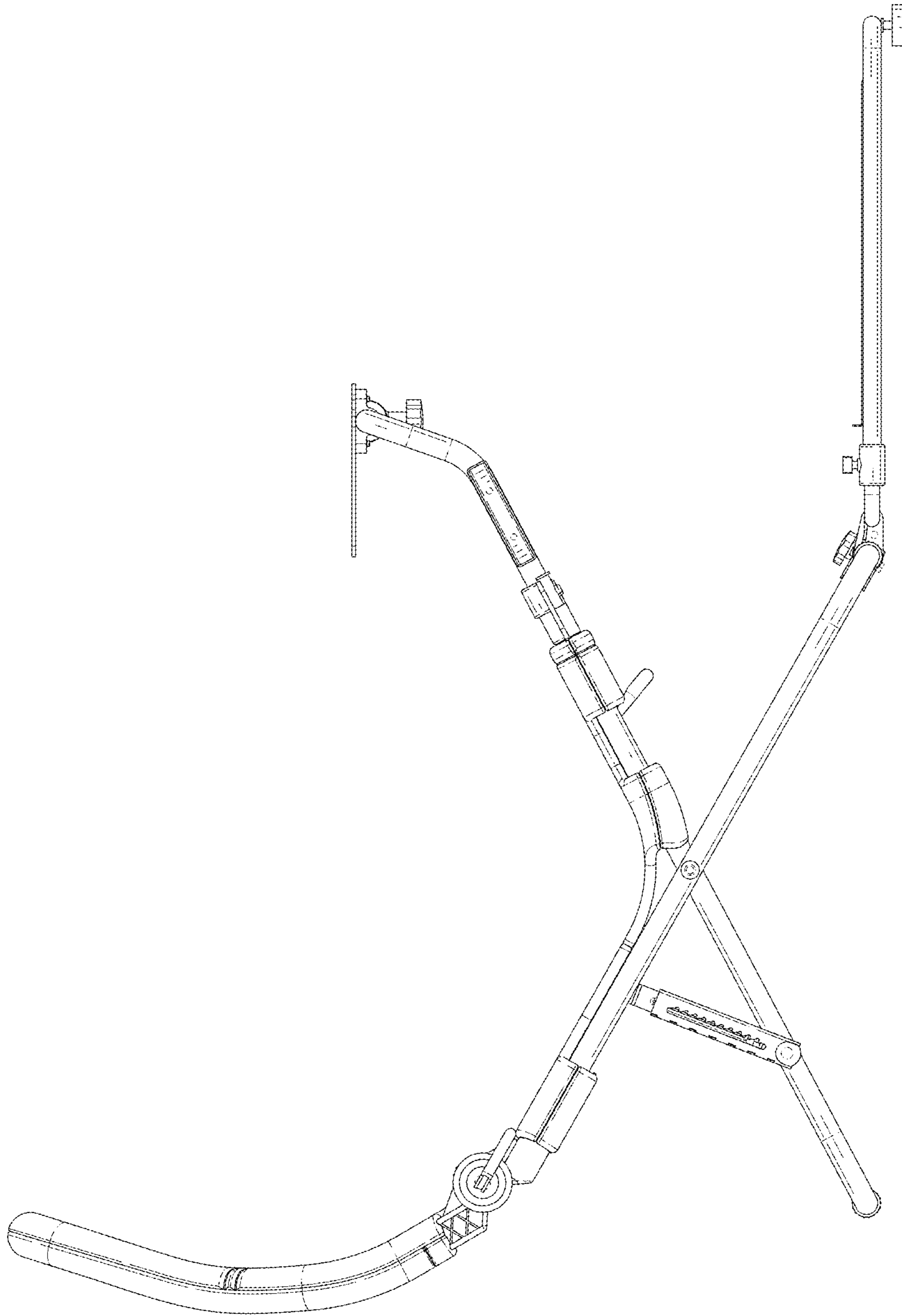

FIG. 5

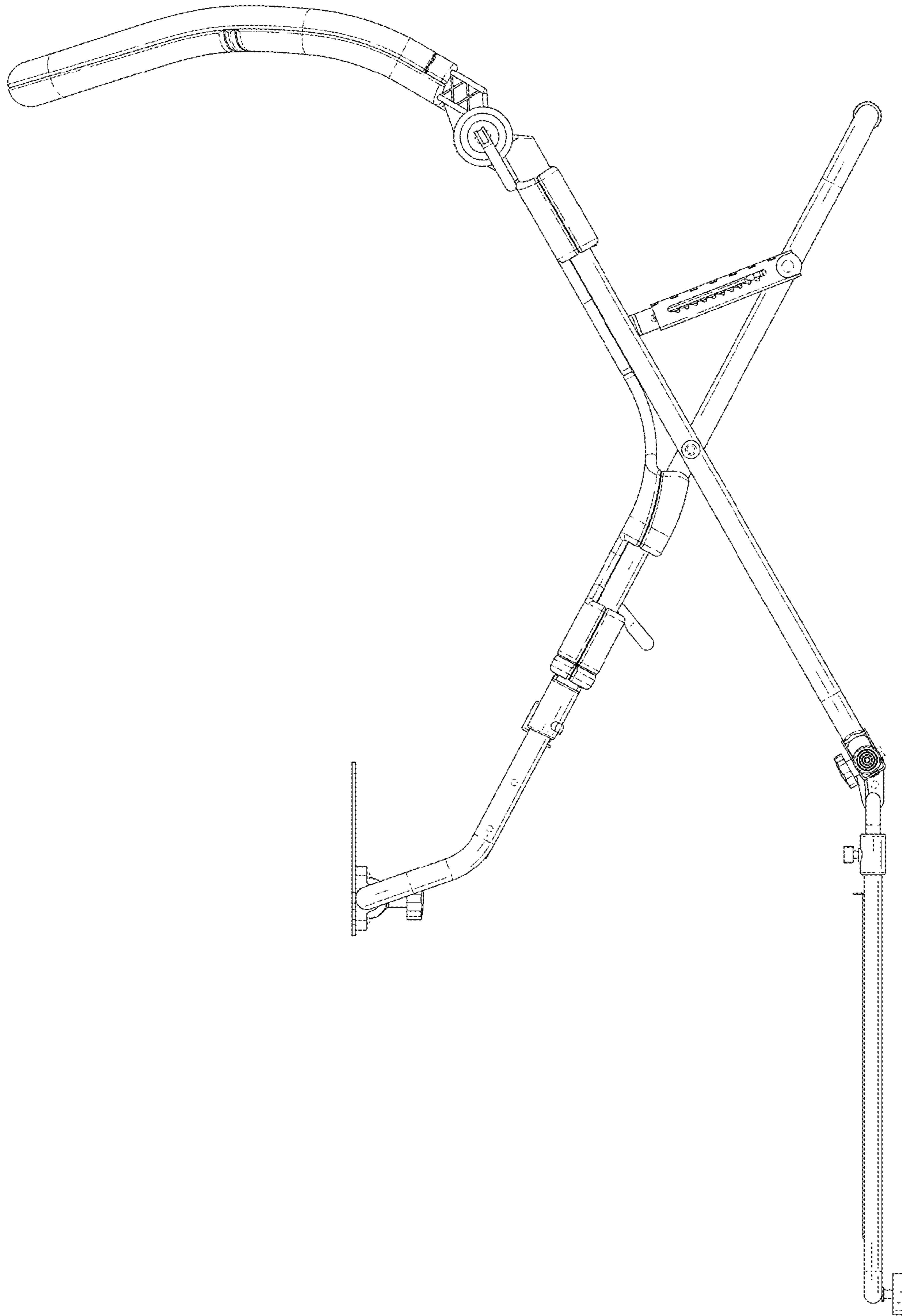

FIG. 6

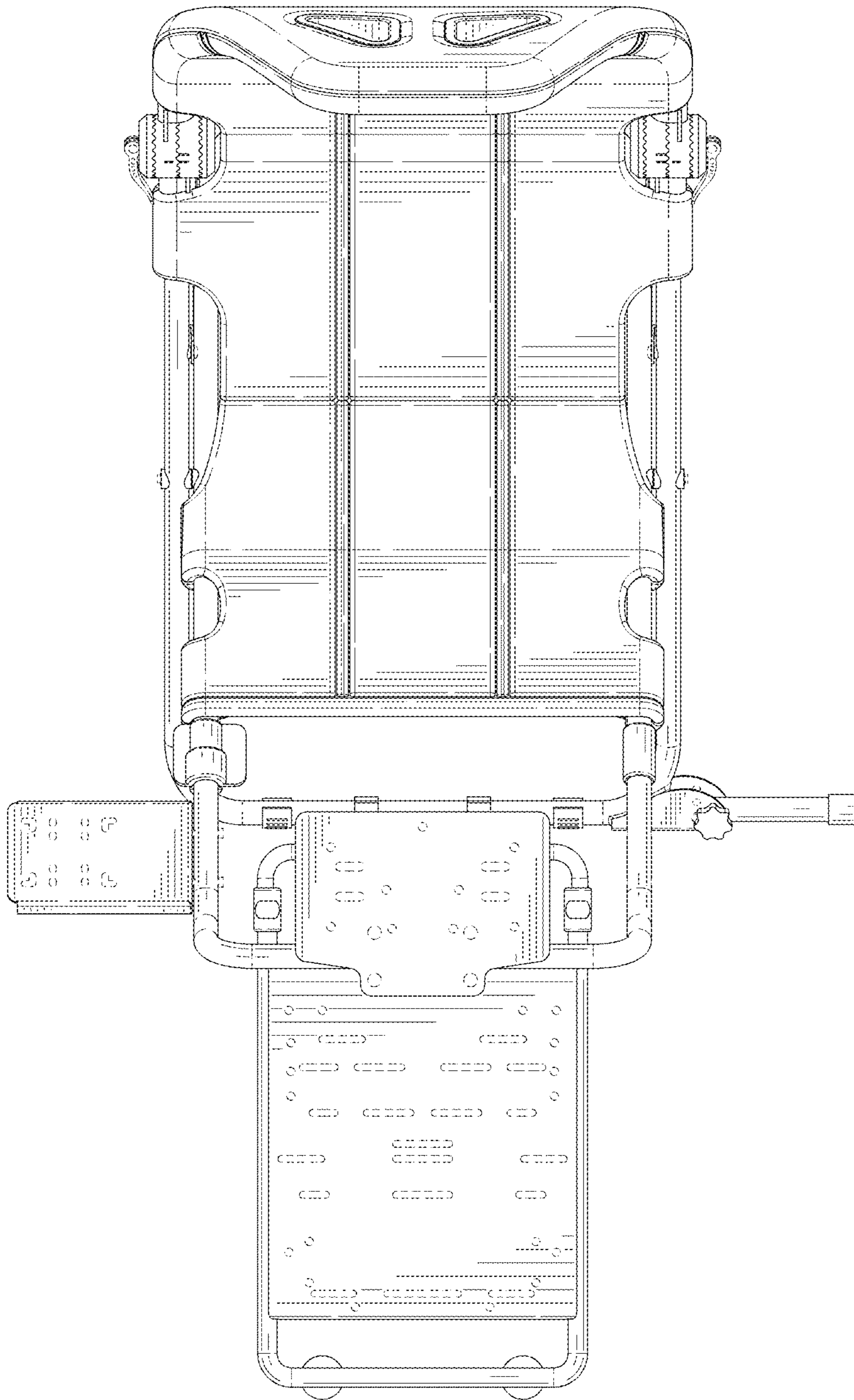

FIG. 7

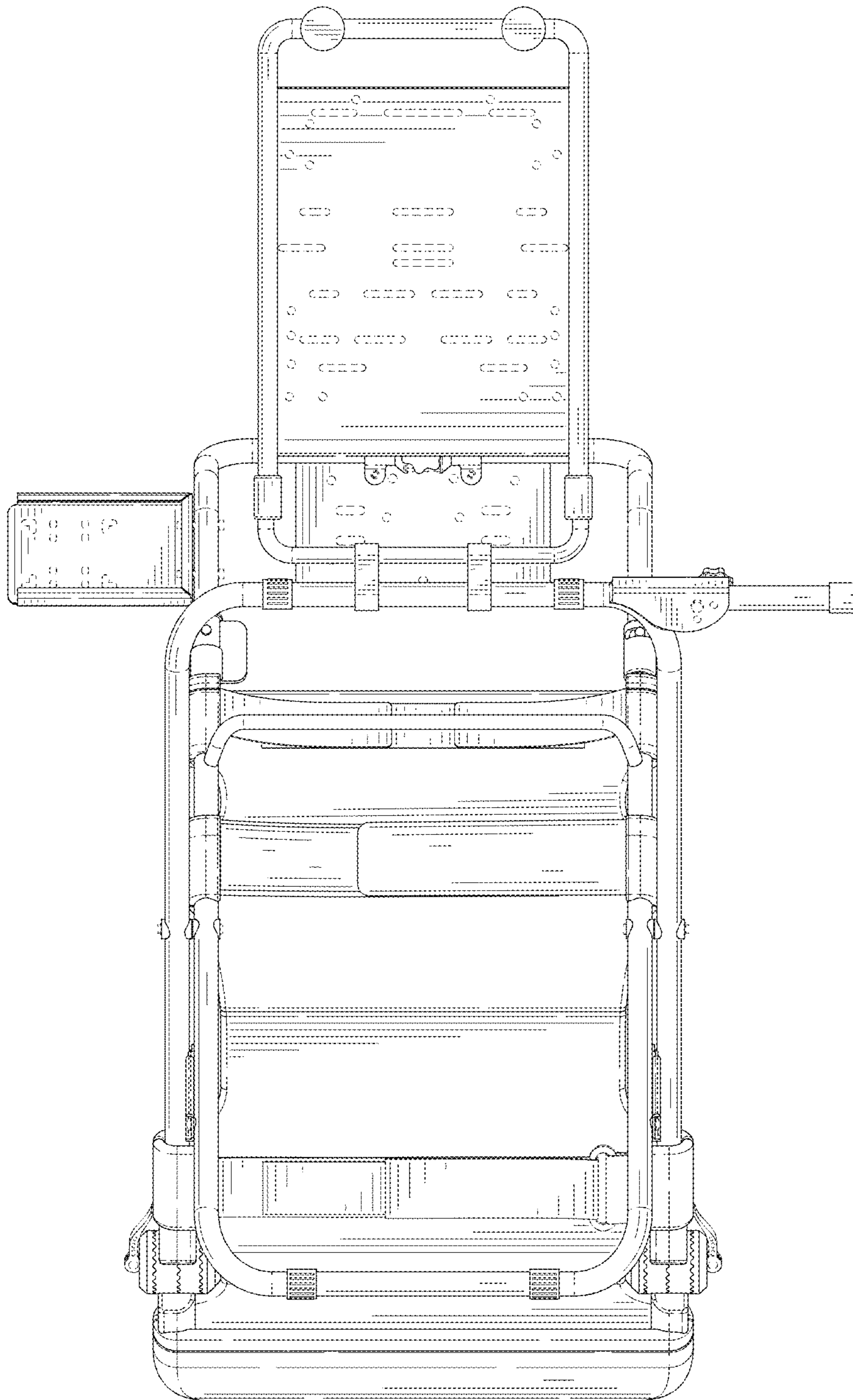

FIG. 8

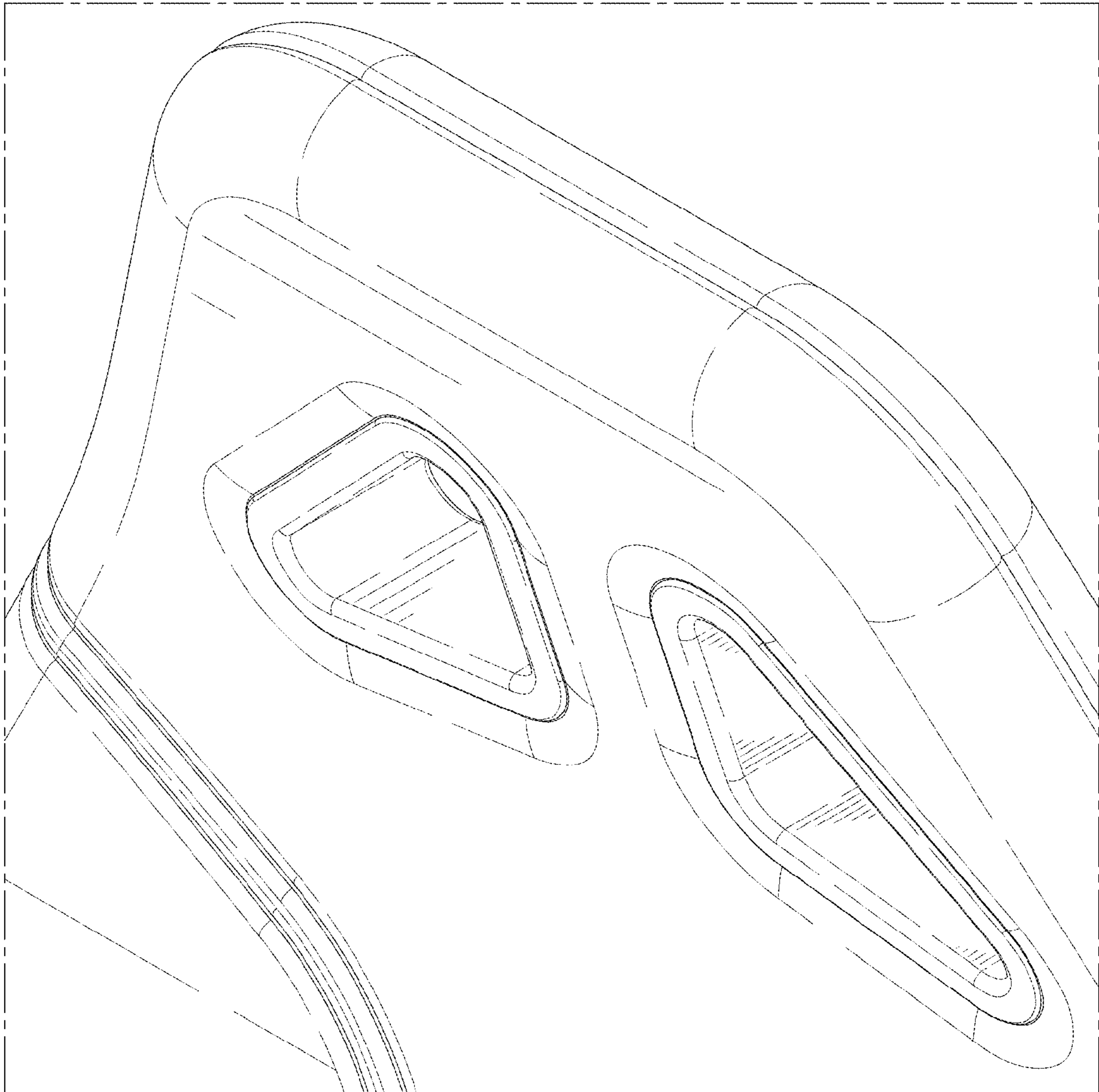

FIG. 9

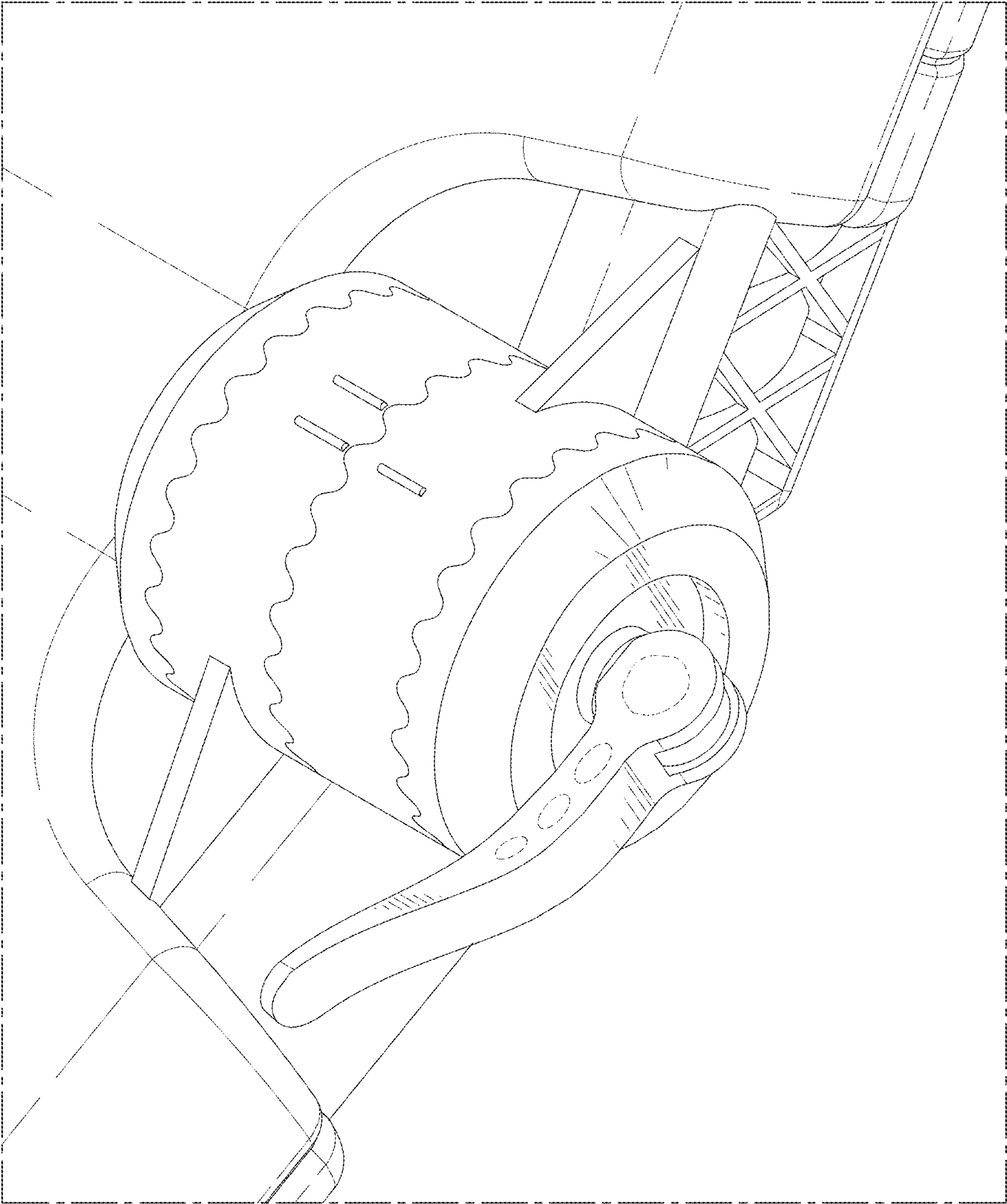

FIG. 10

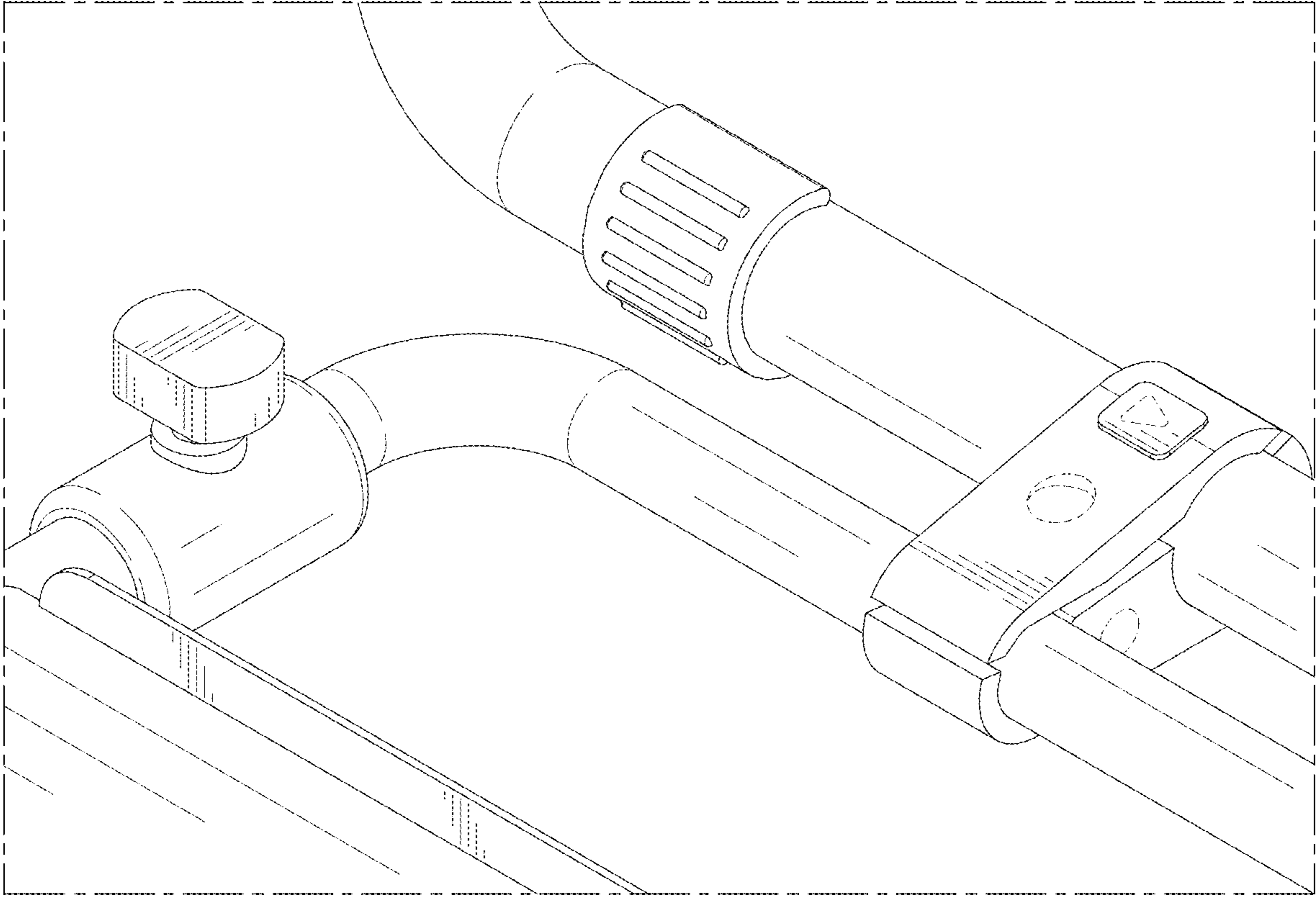

FIG. 11

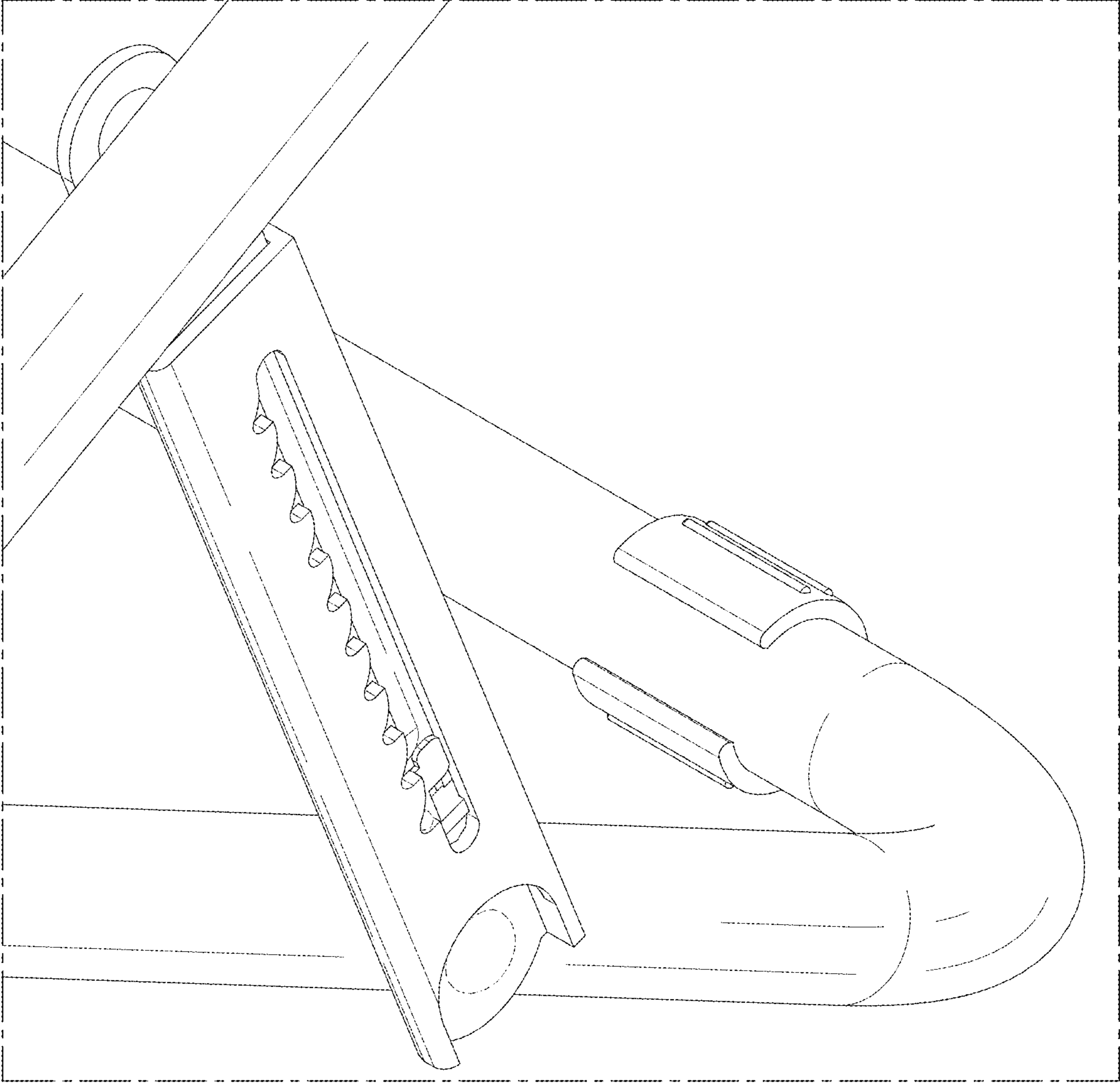

FIG. 12

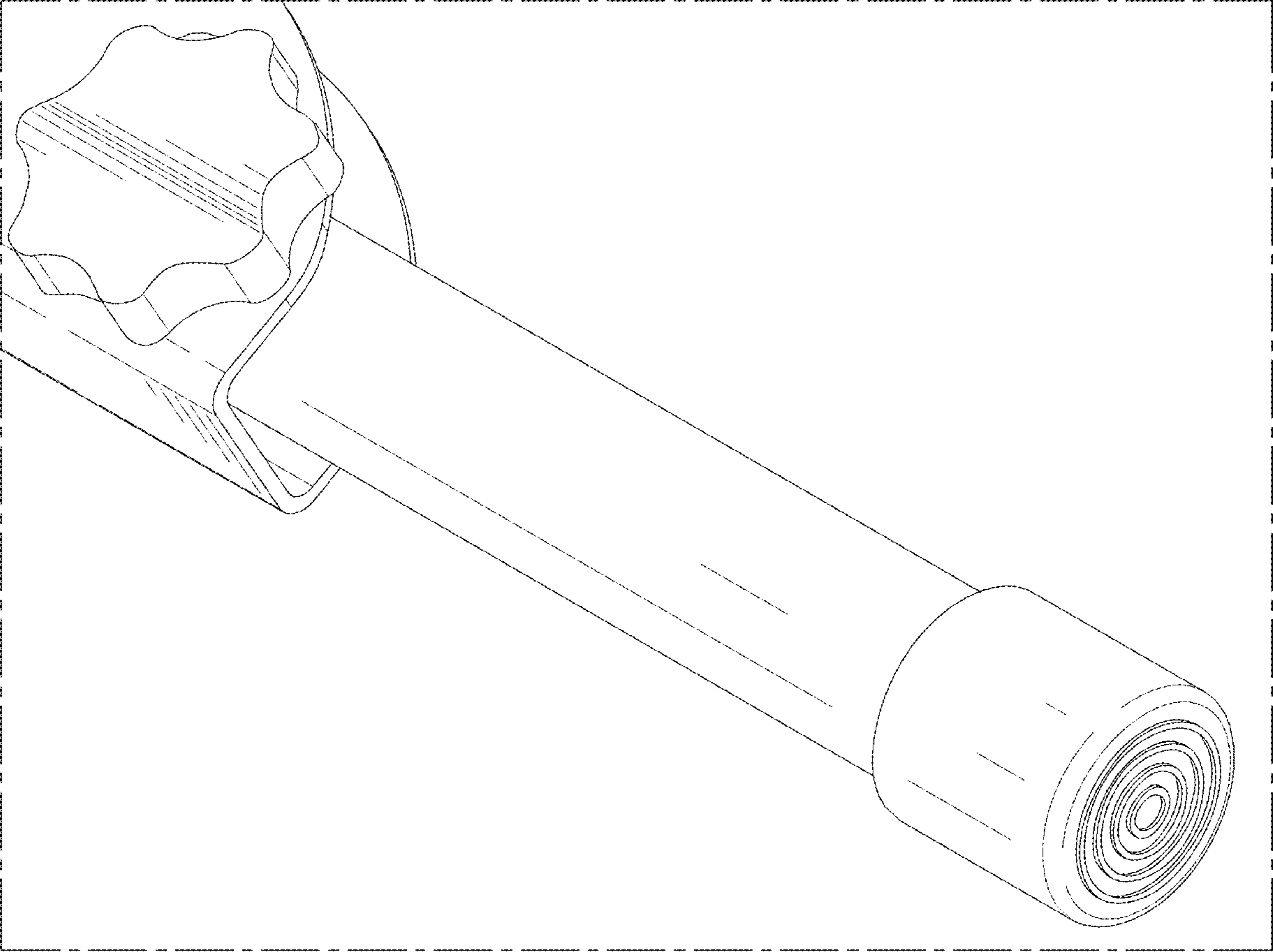

FIG. 13

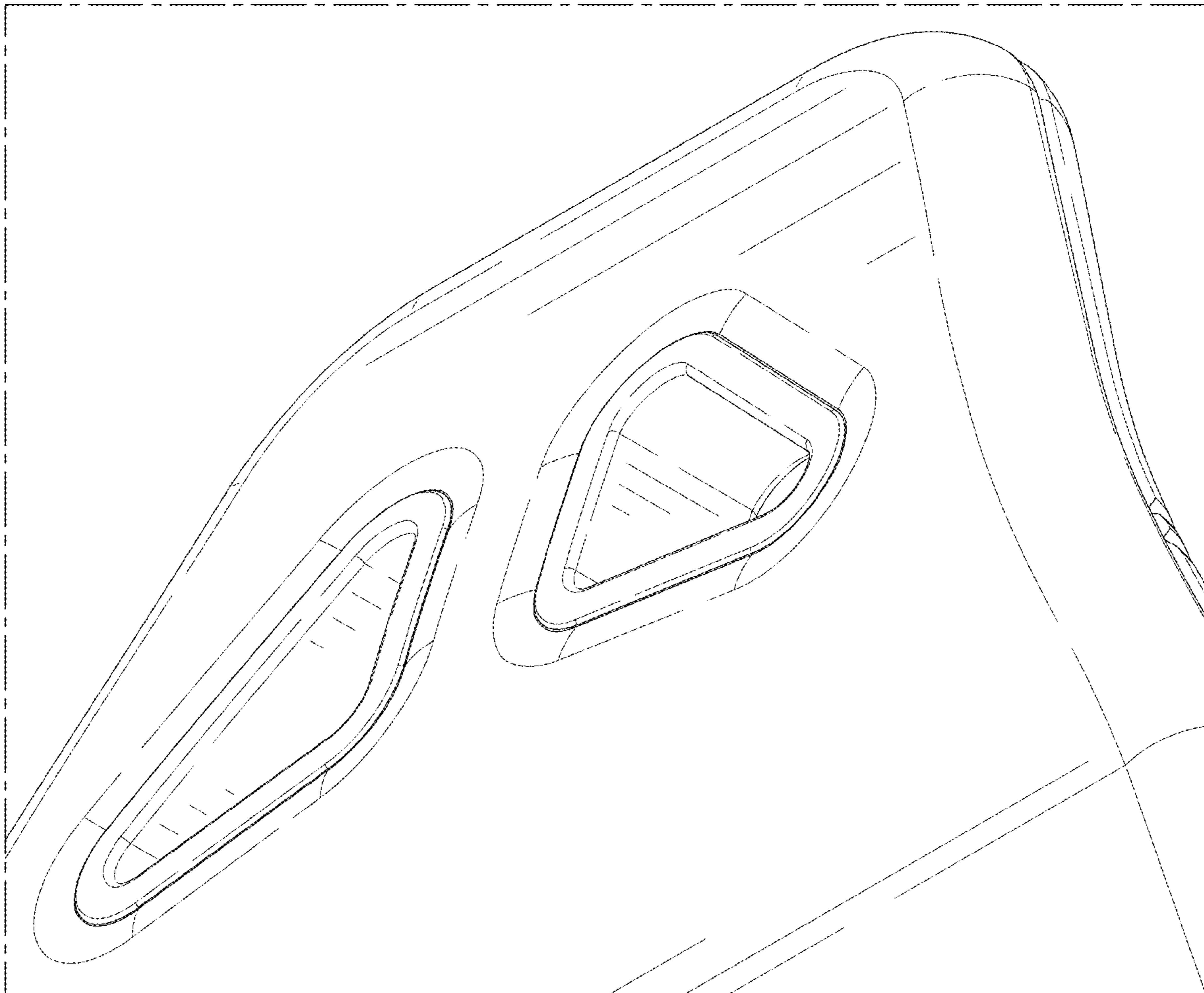

FIG. 14

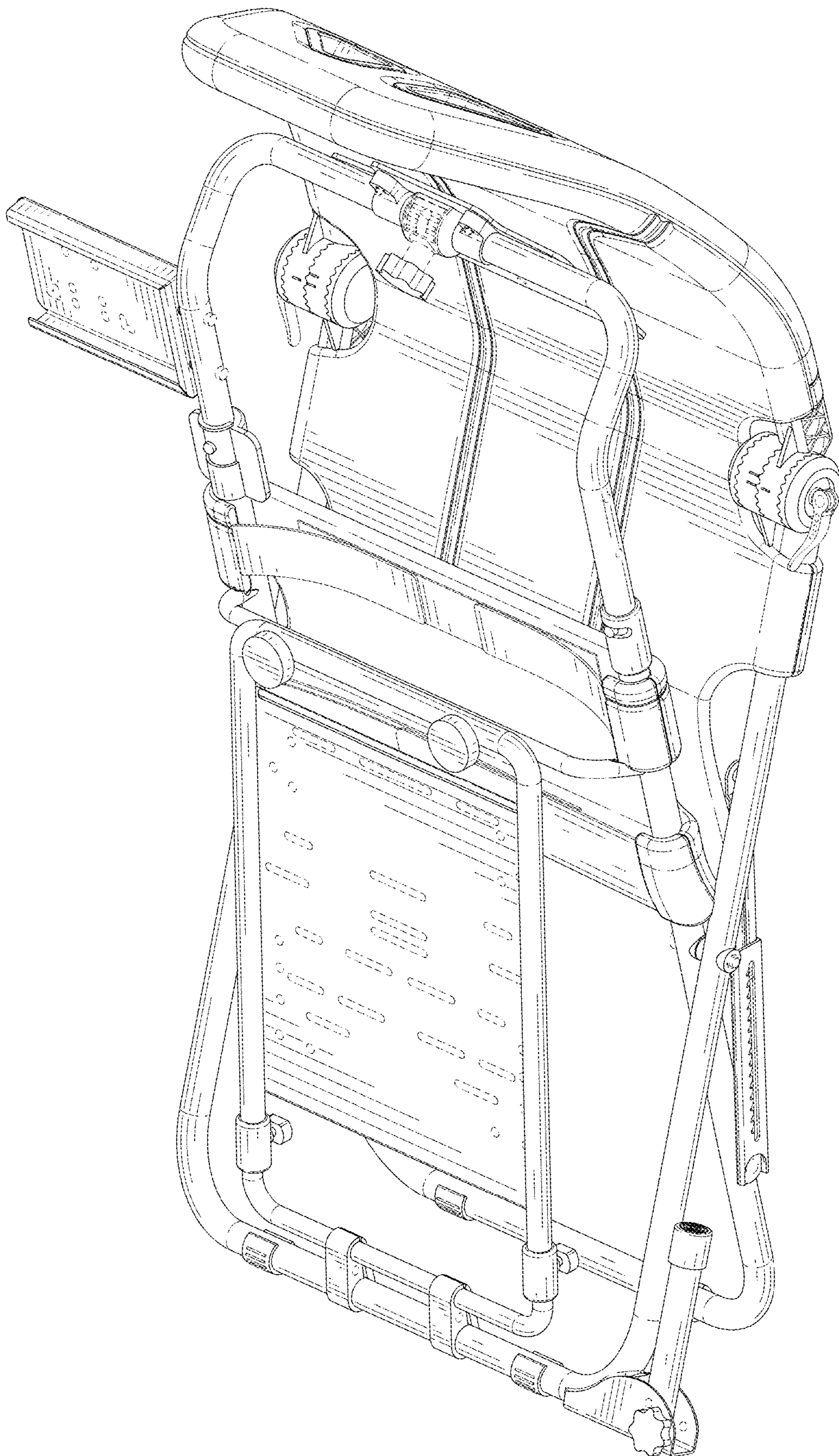

FIG. 15