



US00D986814S

(12) **United States Design Patent** (10) **Patent No.:** **US D986,814 S**
Liu et al. (45) **Date of Patent:** **** May 23, 2023**

(54) **POWER SUPPLY DEVICE**
(71) Applicant: **Shenzhen Smoore Technology Limited**, Shenzhen (CN)
(72) Inventors: **Yu Liu**, Shenzhen (CN); **You Shi**, Shenzhen (CN); **Baosheng Lai**, Shenzhen (CN)
(73) Assignee: **SHENZHEN SMOORE TECHNOLOGY LIMITED**, Shenzhen (CN)

D870,368 S 12/2019 Leon Duque et al.
D875,305 S 2/2020 Lai
D875,306 S 2/2020 Pan
D893,094 S 8/2020 Wang
D898,278 S * 10/2020 Carlberg D27/162
D898,991 S * 10/2020 Pan D27/162
D900,385 S 10/2020 Wang
D900,386 S 10/2020 Wang
D902,473 S 11/2020 Li
D902,480 S 11/2020 Chen et al.
D908,279 S 1/2021 Li

(Continued)

(**) Term: **15 Years**

(21) Appl. No.: **29/754,970**

(22) Filed: **Oct. 15, 2020**

Related U.S. Application Data

(63) Continuation-in-part of application No. 29/748,575, filed on Aug. 31, 2020, now Pat. No. Des. 953,623.

(30) **Foreign Application Priority Data**

May 19, 2020 (CN) 202030231809.1

(51) **LOC (14) Cl.** **27-02**

(52) **U.S. Cl.**
USPC **D27/162**

(58) **Field of Classification Search**
USPC D27/162, 100, 101, 163–165, 172, 174, D27/183, 185–194; D13/103, 107–109
CPC A24F 47/002; A24F 47/006; A24F 47/008; A61M 15/00; A61M 15/06
See application file for complete search history.

(56) **References Cited**

U.S. PATENT DOCUMENTS

D851,328 S * 6/2019 Smith D27/162
D854,741 S * 7/2019 Smith D27/162
D864,474 S * 10/2019 Smith D27/162

OTHER PUBLICATIONS

Non Final Office Action, American U.S. Appl. No. 29/754,995, dated Dec. 24, 2021(16 pages).

Primary Examiner — Rebecca Tsehaye

(57) **CLAIM**

The ornamental design for the power supply device, as shown and described.

DESCRIPTION

FIG. 1 is a perspective view of a power supply device; FIG. 2 is another perspective view thereof; FIG. 3 is a front elevational view thereof; FIG. 4 is a rear elevational view thereof; FIG. 5 is a left side elevational view thereof; FIG. 6 is a right side elevational view thereof; FIG. 7 is an enlarged top plan view thereof; FIG. 8 is an enlarged bottom plan view thereof; and, FIG. 9 is an enlarged view of area 9 circumscribed in FIG. 2.

The broken lines consisting of evenly spaced dash lines in the drawing depict portions of the power supply device that form no part of the claimed design. The broken lines consisting of short and long dash lines encircling the enlarged detail views are for annotative purposes that form no part of the claimed design.

1 Claim, 9 Drawing Sheets

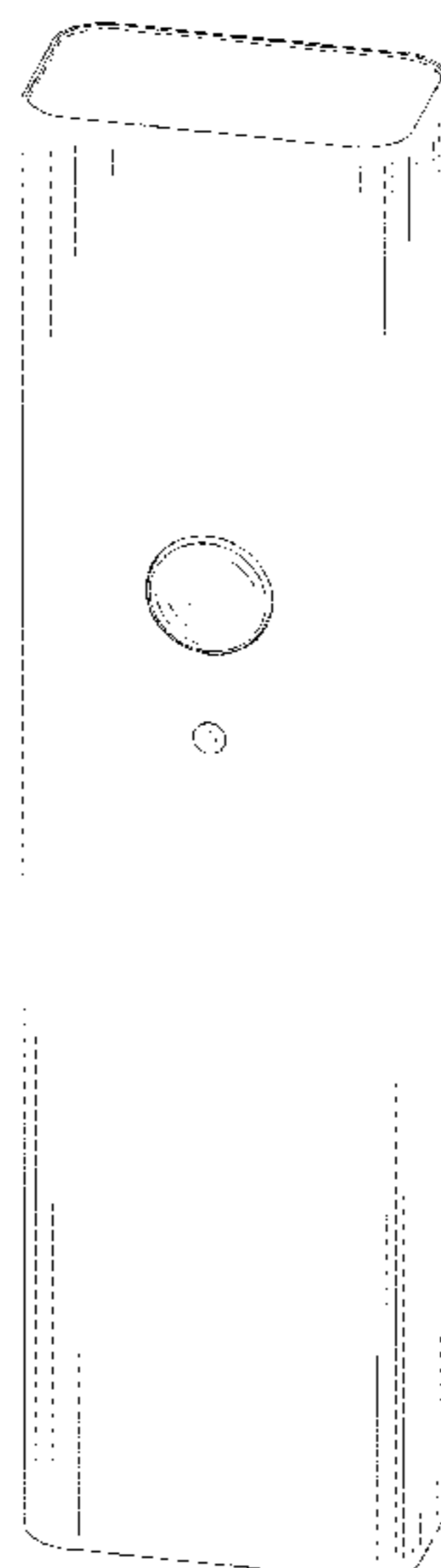

(56)

References Cited

U.S. PATENT DOCUMENTS

D909,667 S *	2/2021	Chen	D27/162
D909,668 S *	2/2021	Chen	D27/162
D911,600 S	2/2021	Chen	
D914,276 S	3/2021	Lai	
D918,467 S	5/2021	Wang	
D921,283 S *	6/2021	Laidlaw	D27/162
D923,240 S	6/2021	Wang	
D923,864 S	6/2021	Carlberg et al.	
D925,115 S *	7/2021	Wang	D27/162
D925,821 S *	7/2021	Cruice	D27/162
D927,772 S	8/2021	Han	
D928,394 S	8/2021	Jones et al.	
D929,034 S	8/2021	Li	
D929,648 S	8/2021	Wang	
D929,650 S *	8/2021	Cruice	D27/162
D930,236 S	9/2021	Fornarelli	
D930,895 S *	9/2021	Fornarelli	D27/162
D932,094 S	9/2021	Laidlaw et al.	
D933,285 S	10/2021	Wang	
D933,286 S	10/2021	Weiss et al.	
D934,491 S	10/2021	Han	
D937,477 S	11/2021	Li	
D943,150 S *	2/2022	Chen	D27/162
D943,161 S *	2/2022	Cheung	D27/162
D943,179 S *	2/2022	Xie	D27/162

* cited by examiner

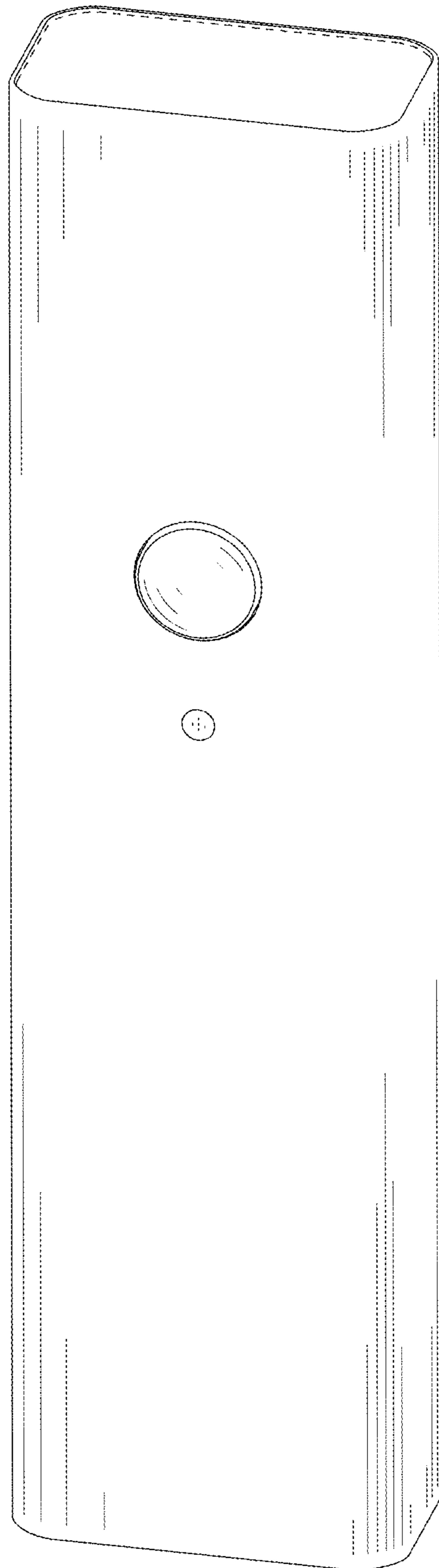

FIG. 1

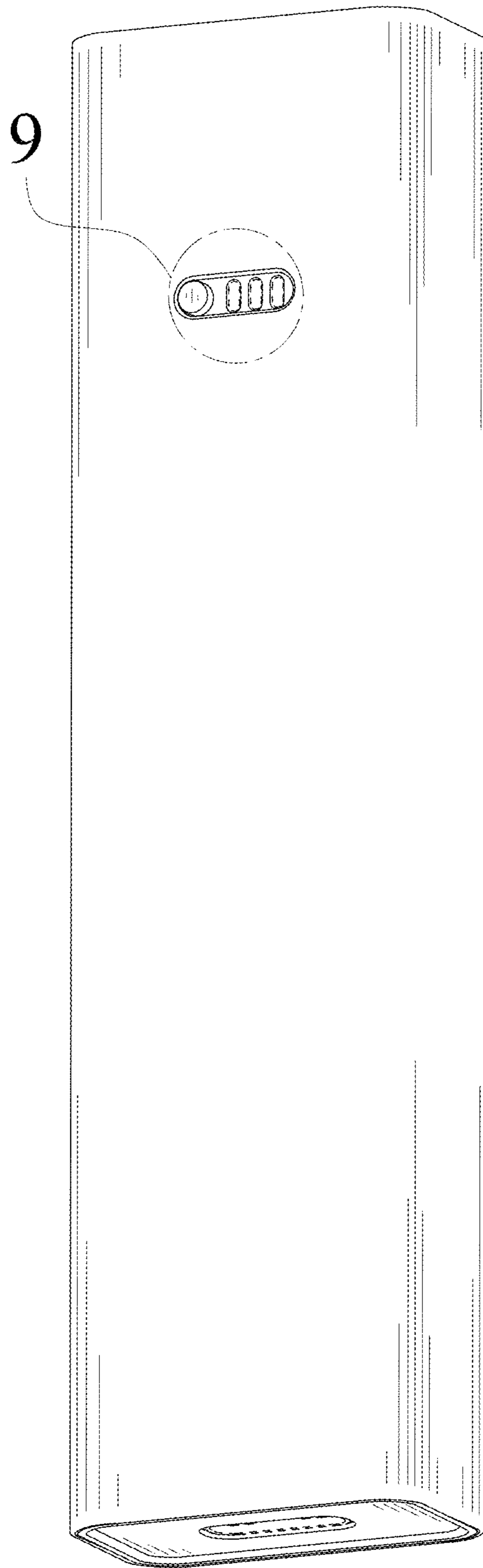

FIG. 2

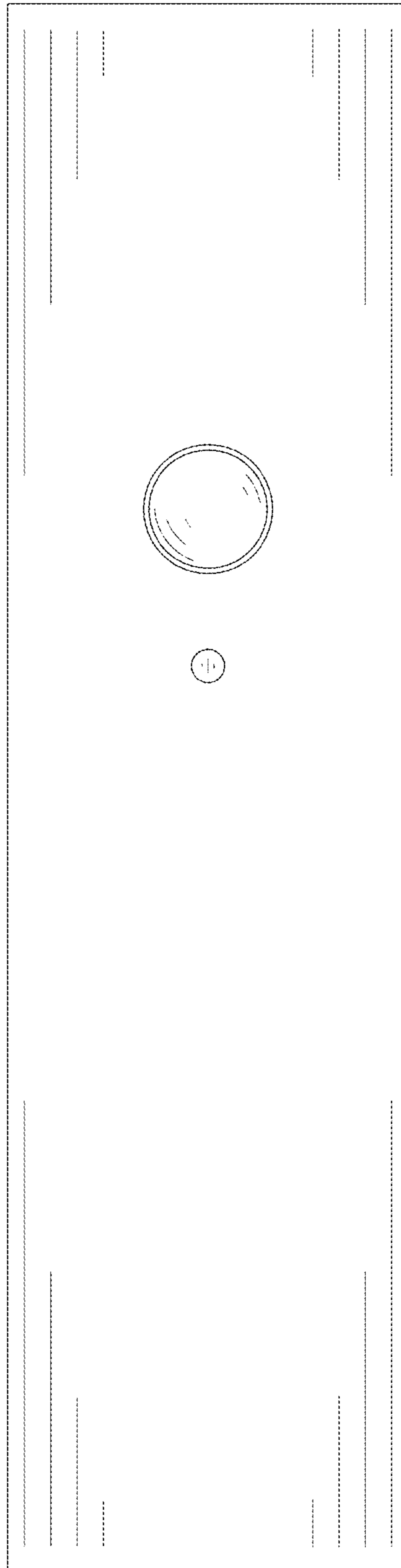

FIG. 3

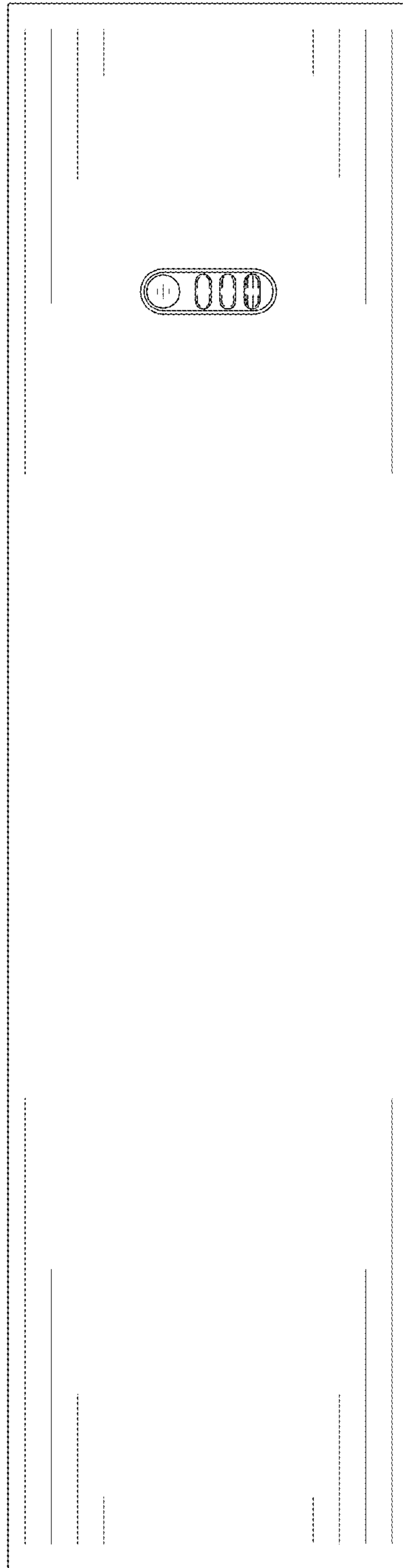

FIG. 4

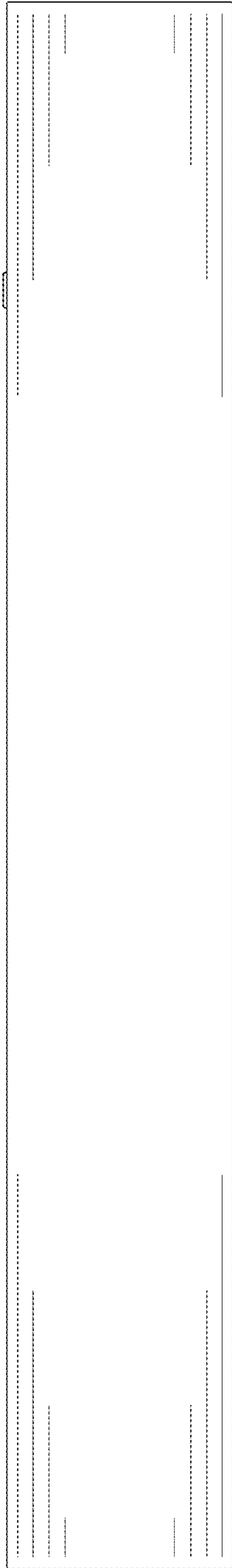

FIG. 5

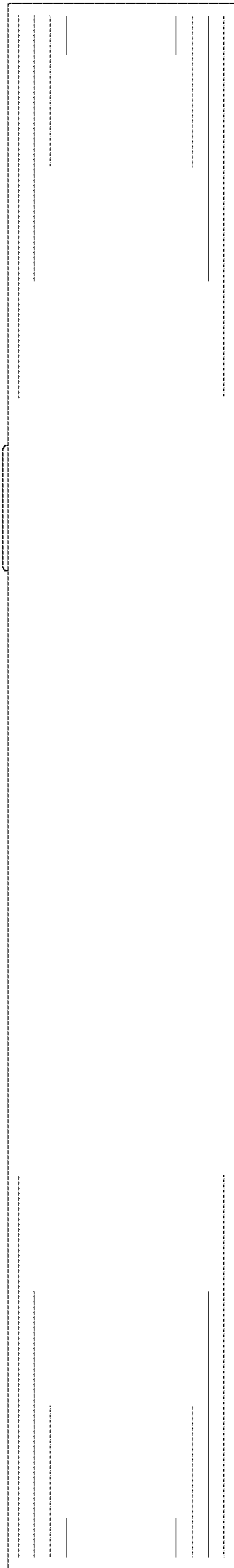

FIG. 6

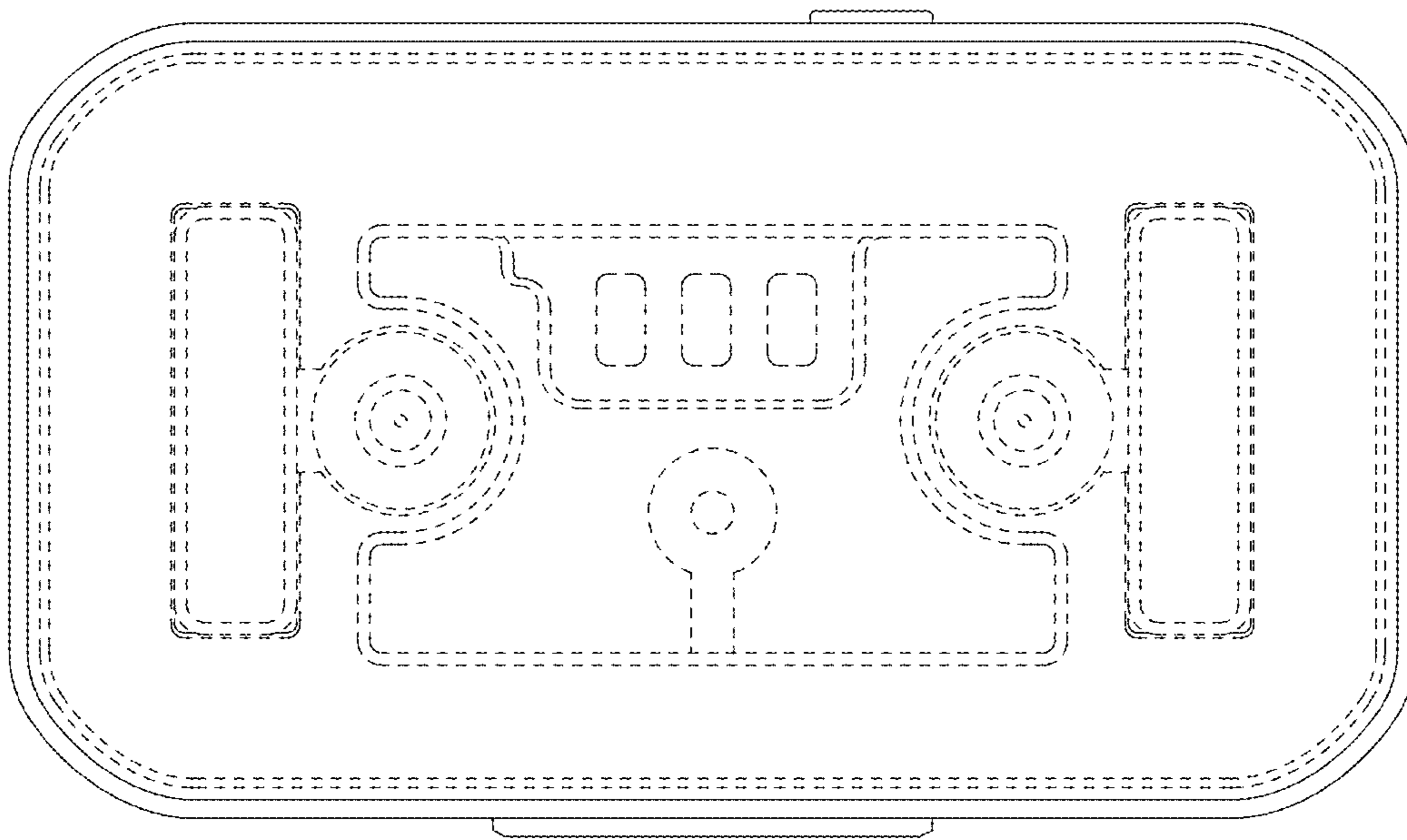

FIG. 7

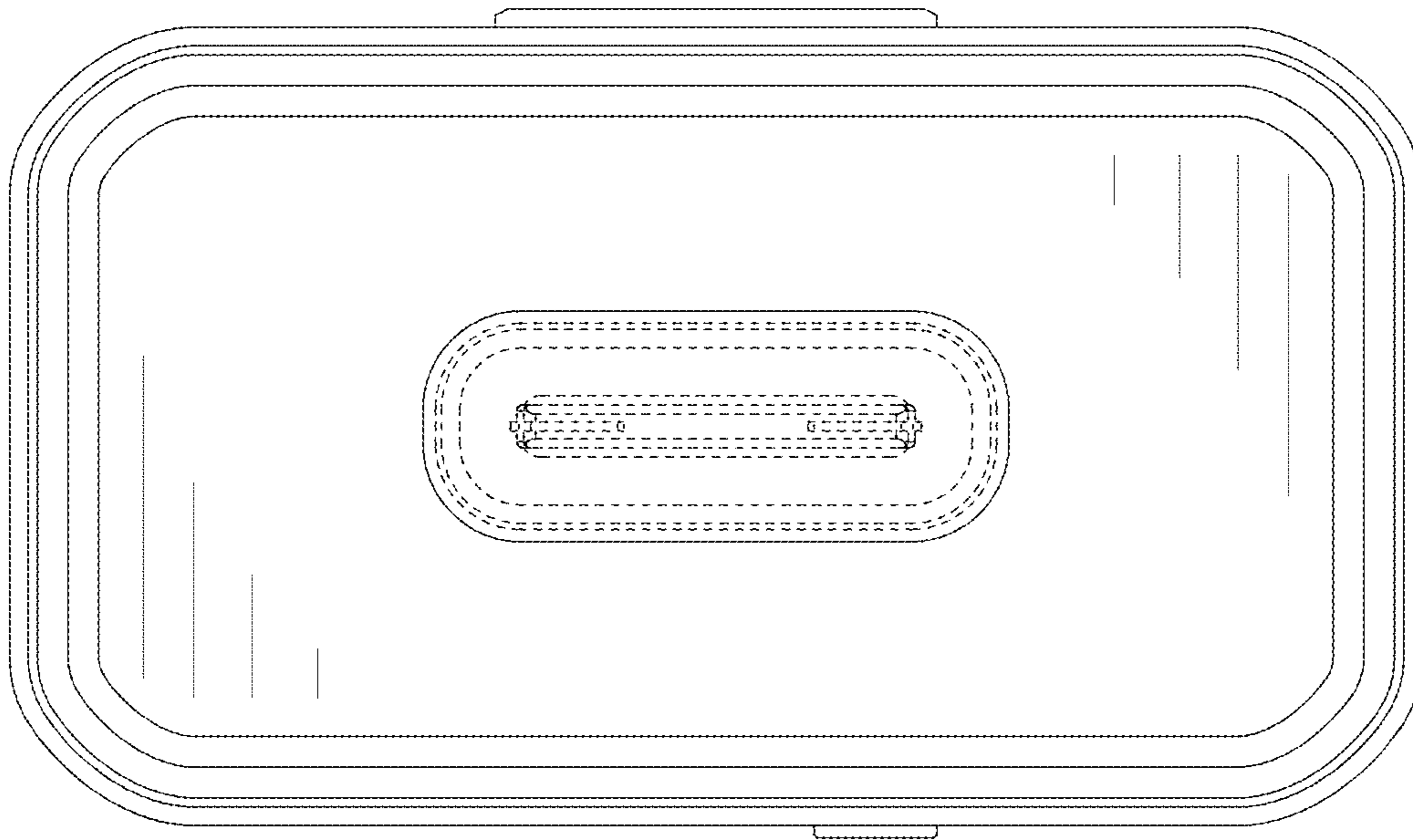

FIG. 8

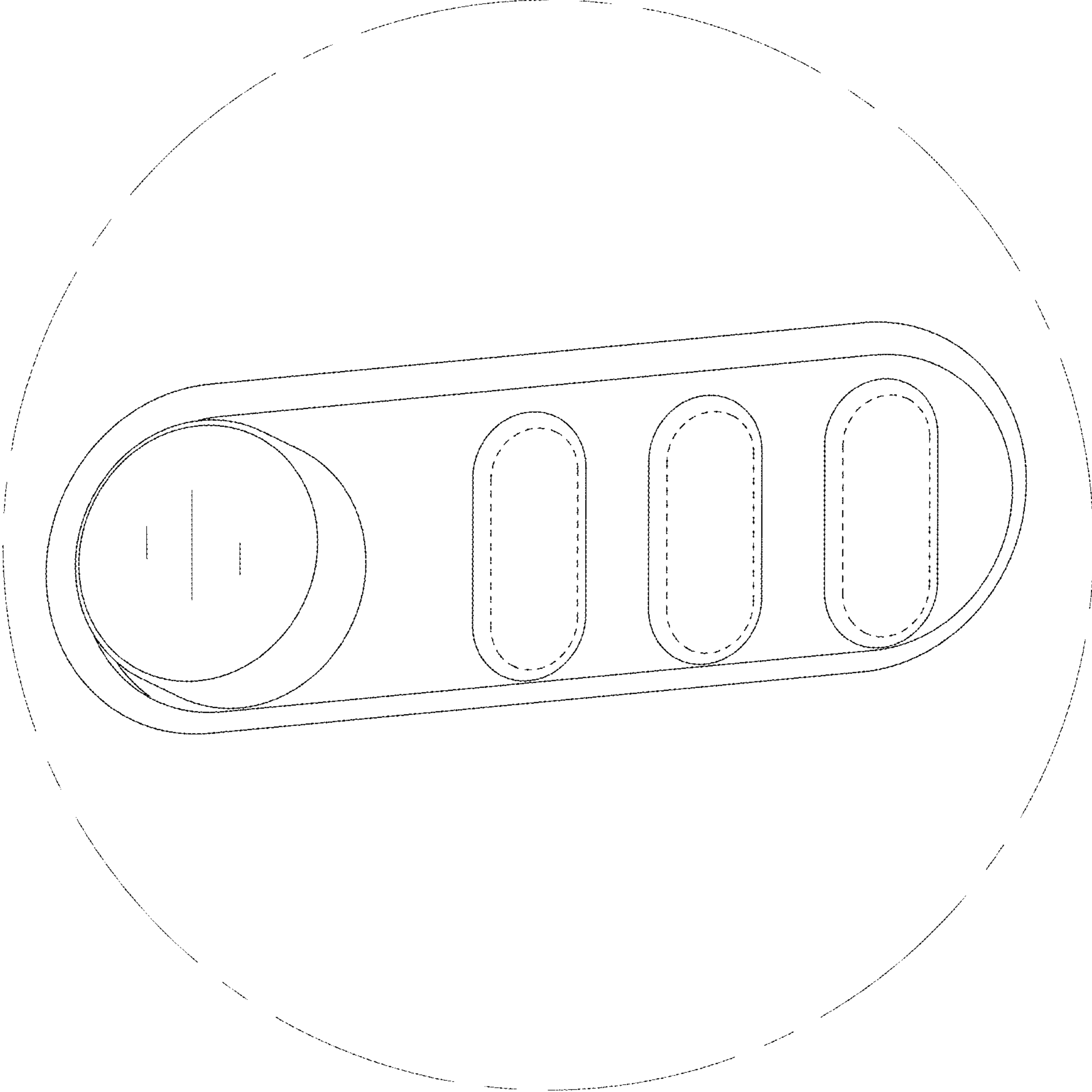

FIG. 9