



US00D986679S

(12) **United States Design Patent** (10) **Patent No.:** **US D986,679 S**  
**McConnell et al.** (45) **Date of Patent:** **\*\* May 23, 2023**

- (54) **FOOD PROCESSING ATTACHMENT**
- (71) Applicant: **WHIRLPOOL CORPORATION**,  
Benton Harbor, MI (US)
- (72) Inventors: **John W. McConnell**, St. Joseph, MI  
(US); **Wenkai Wu**, Aurora, IL (US)
- (73) Assignee: **Whirlpool Corporation**, Benton  
Harbor, MI (US)
- (\*\*) Term: **15 Years**
- (21) Appl. No.: **29/855,539**
- (22) Filed: **Oct. 4, 2022**

**Related U.S. Application Data**

- (63) Continuation of application No. 29/834,443, filed on  
Apr. 12, 2022, now Pat. No. Des. 969,553, which is  
(Continued)
- (51) **LOC (14) Cl.** ..... **31-00**
- (52) **U.S. Cl.**  
USPC ..... **D7/412**; D7/381; D7/384
- (58) **Field of Classification Search**  
USPC ..... D7/372, 376–386, 412–413, 602, 629,  
D7/665–666, 669, 672, 679, 693–694  
CPC .. A01F 11/06; A21C 1/02; A21C 1/04; A23N  
1/00; A23N 1/02; A23N 4/026; A23N  
4/18; A47J 17/04; A47J 17/16; A47J  
43/04; A47J 43/25; A47J 43/27; A47J  
43/042; A47J 43/044; A47J 43/046; A47J  
43/06; A47J 43/075; A47J 43/0722; A47J  
43/0727; A47J 25/00; B01F 3/00; B01F  
3/0807; B01F 3/0853; B01F 13/0059;  
B01F 13/0064; B02C 1/08; B02C 2/04;  
B02C 4/42; B02C 4/142; B02C 4/143;  
B02C 4/423; B02C 13/1835; B26D 3/11;  
B26D 3/185; B26D 3/283; B28C 5/10;  
B28C 5/12; B28C 5/14; B28C 5/16  
See application file for complete search history.

(56) **References Cited**

U.S. PATENT DOCUMENTS

- RE9,774 E 6/1881 Whittemore
  - 242,660 A 6/1881 Law
- (Continued)

OTHER PUBLICATIONS

Commercial Meat Cuber Tenderizer. Date First Available on Amazon.  
com Nov. 18, 2021. [https://www.amazon.com/dp/B09M6Q4Y9N/](https://www.amazon.com/dp/B09M6Q4Y9N/ref)  
ref (Year: 2021).\*

*Primary Examiner* — Ricky Pham

(74) *Attorney, Agent, or Firm* — Price Heneveld LLP

(57) **CLAIM**

We claim the ornamental design for a food processing attachment, as shown and described.

**DESCRIPTION**

FIG. 1 is a top perspective view of the food processing attachment of the present invention;  
 FIG. 2 is bottom perspective view of the food processing attachment of the present invention;  
 FIG. 3 is a first side elevation view of the food processing attachment of the present invention;  
 FIG. 4 is a second side elevation view of the food processing attachment of the present invention;  
 FIG. 5 is a third side elevation view of the food processing attachment of the present invention;  
 FIG. 6 is a fourth side elevation view of the food processing attachment of the present invention;  
 FIG. 7 is a top plan view of the food processing attachment of the present invention; and,  
 FIG. 8 is a bottom plan view of the food processing attachment of the present invention.  
 The broken lines in the figures are for contextual purposes or show the environment and form no part of the claimed design.

**1 Claim, 7 Drawing Sheets**

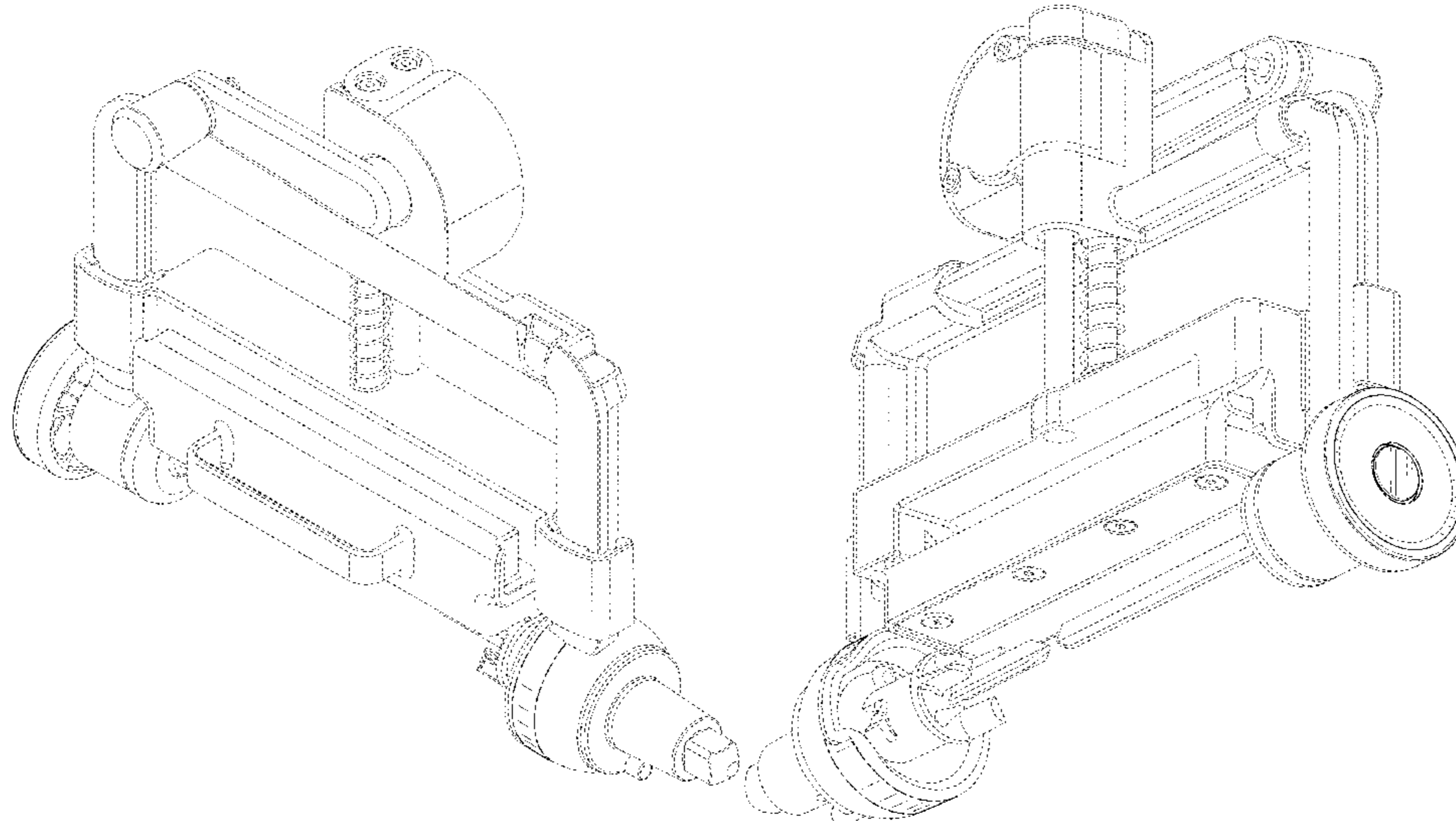

**Related U.S. Application Data**

a continuation of application No. 29/815,126, filed on Nov. 11, 2021, now Pat. No. Des. 953,113, which is a continuation of application No. 29/787,442, filed on Jun. 7, 2021, now Pat. No. Des. 938,780, which is a continuation of application No. 29/763,359, filed on Dec. 22, 2020, now Pat. No. Des. 924,629, which is a continuation of application No. 29/754,037, filed on Oct. 6, 2020, now Pat. No. Des. 909,130, which is a continuation of application No. 29/740,104, filed on Jul. 1, 2020, now Pat. No. Des. 901,242, which is a continuation of application No. 29/713,992, filed on Nov. 20, 2019, now Pat. No. Des. 891,862, which is a continuation of application No. 29/698,967, filed on Jul. 22, 2019, now Pat. No. Des. 874,219, which is a continuation of application No. 29/663,694, filed on Sep. 18, 2018, now Pat. No. Des. 861,425, which is a continuation of application No. 29/589,335, filed on Dec. 30, 2016, now Pat. No. Des. 831,421.

(56)

**References Cited**

U.S. PATENT DOCUMENTS

255,856	A	4/1882	Heizmann	
256,214	A	4/1882	Heizmann	
256,800	A	4/1882	Holton	
281,559	A *	7/1883	Rippien .....	A47J 17/16 99/543
292,554	A	1/1884	Geer	
303,490	A	8/1884	Clark	
310,196	A	1/1885	Goodell	
315,158	A	4/1885	Oaks	
319,905	A	6/1885	Hudson	
430,139	A	6/1890	Meyer	
633,932	A	9/1899	Williamson	
954,340	A	4/1910	Phillips	
959,137	A	5/1910	Hinchliffe	
1,008,555	A	11/1911	Mower	
1,256,751	A	2/1918	Wenzel	
1,511,137	A	10/1924	Pichler	
1,956,492	A	4/1934	China	
1,966,186	A	7/1934	Remnsnider	
2,056,843	A	10/1936	Erro	
2,069,654	A	2/1937	Jeppson et al.	
2,156,645	A	5/1939	Waller	
2,299,092	A	10/1942	Johnson	
2,307,829	A	1/1943	Ellis	
2,361,241	A	10/1944	Rogers	
2,375,489	A	5/1945	Oskow	
2,410,683	A	11/1946	Marquez	
2,461,249	A	2/1949	Anderson	
2,464,993	A	3/1949	Ross	
2,489,581	A	11/1949	Mason	
2,508,868	A	5/1950	Ross	
2,566,568	A	9/1951	Ives	
2,693,210	A	11/1954	Gustafson	
3,091,269	A	5/1963	Burns et al.	
3,211,202	A	10/1965	Mason	
3,357,469	A	12/1967	Pease et al.	
RE26,684	E	10/1969	Mason	
3,881,406	A	5/1975	Perez	
3,952,621	A	4/1976	Chambos	
4,038,915	A	8/1977	Saito	
4,579,028	A	4/1986	Neidhardt	
D370,383	S	6/1996	Brefka	

5,557,998	A	9/1996	Schwartz et al.	
5,690,022	A	11/1997	Chai	
5,878,643	A	3/1999	Hwang	
5,950,528	A	9/1999	Wang	
D414,983	S	10/1999	Wong	
5,970,860	A	10/1999	Yip	
6,053,098	A	4/2000	Yamamoto	
6,148,719	A	11/2000	Poltielov	
6,314,849	B1	11/2001	Arrasmith	
6,516,713	B1	2/2003	Holmander	
6,523,464	B1	2/2003	Widelo	
6,854,383	B2 *	2/2005	Wang .....	A47J 17/16 99/542
7,032,491	B2	4/2006	Fischer	
D526,539	S	8/2006	Yip	
D531,850	S	11/2006	Wong	
D535,534	S	1/2007	Wong	
D541,368	S	4/2007	Hoffman	
7,207,510	B2	4/2007	Wong	
D558,002	S	12/2007	Meyer	
D669,324	S	10/2012	Bodum	
8,596,176	B1	12/2013	Wagner	
D715,094	S	10/2014	Cornu et al.	
D716,601	S	11/2014	Taghizadeh et al.	
D725,440	S	3/2015	Kim	
D773,894	S	12/2016	Benoit et al.	
D779,294	S	2/2017	Friedman	
D793,181	S	8/2017	Wong	
9,731,428	B2	8/2017	Levine et al.	
D796,917	S	9/2017	Wong	
D797,495	S	9/2017	McConnell et al.	
D809,881	S	2/2018	Exley	
D815,499	S *	4/2018	Chen .....	D7/693
10,021,904	B1	7/2018	Fikes	
D830,140	S	10/2018	Chen	
D831,421	S	10/2018	McConnell et al.	
10,183,409	B2 *	1/2019	Bagley .....	B26D 3/283
D842,024	S	3/2019	Li	
D858,223	S	9/2019	Feng	
D861,425	S	10/2019	McConnell et al.	
10,433,559	B2	10/2019	DeVito et al.	
D874,219	S	2/2020	McConnell et al.	
D885,822	S	6/2020	McConnell et al.	
D891,862	S	8/2020	McConnell et al.	
D901,242	S	11/2020	McConnell et al.	
D901,970	S	11/2020	Benoit et al.	
10,820,735	B2 *	11/2020	Benoit .....	A47J 43/06
D904,104	S	12/2020	Wong	
D909,130	S	2/2021	McConnell	
D911,097	S	2/2021	Chen	
10,987,821	B2 *	4/2021	Li .....	B26D 3/283
D919,365	S	5/2021	Benoit et al.	
D924,629	S	7/2021	McConnell et al.	
D938,780	S	12/2021	McConnell et al.	
D939,272	S	12/2021	Benoit et al.	
11,278,146	B2 *	3/2022	Cotter .....	A47J 25/00
D949,642	S *	4/2022	Pardon, Jr. ....	D7/672
D953,113	S	5/2022	McConnell et al.	
D966,049	S *	10/2022	Kloeppe .....	D7/669
D969,553	S *	11/2022	McConnell .....	D7/381
2004/0261634	A1	12/2004	Wang	
2008/0314262	A1	12/2008	Stark	
2012/0090480	A1	4/2012	Caspar et al.	
2016/0250768	A1	9/2016	Levine et al.	
2016/0255982	A1	9/2016	Benoit et al.	
2016/0257013	A1	9/2016	Exley	
2016/0332166	A1	11/2016	Chen	
2017/0136644	A1	5/2017	Bagley et al.	

\* cited by examiner

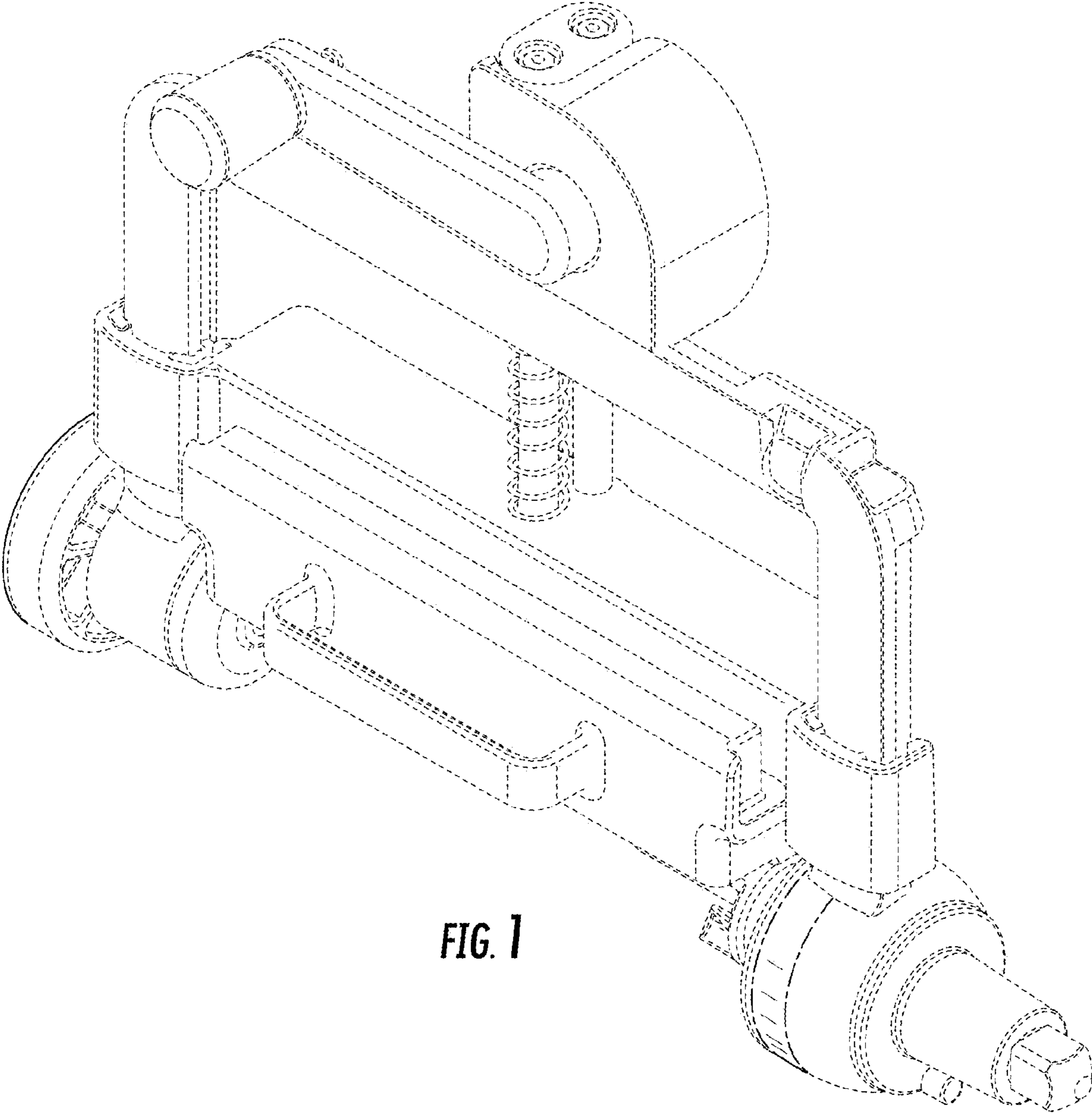

**FIG. 1**

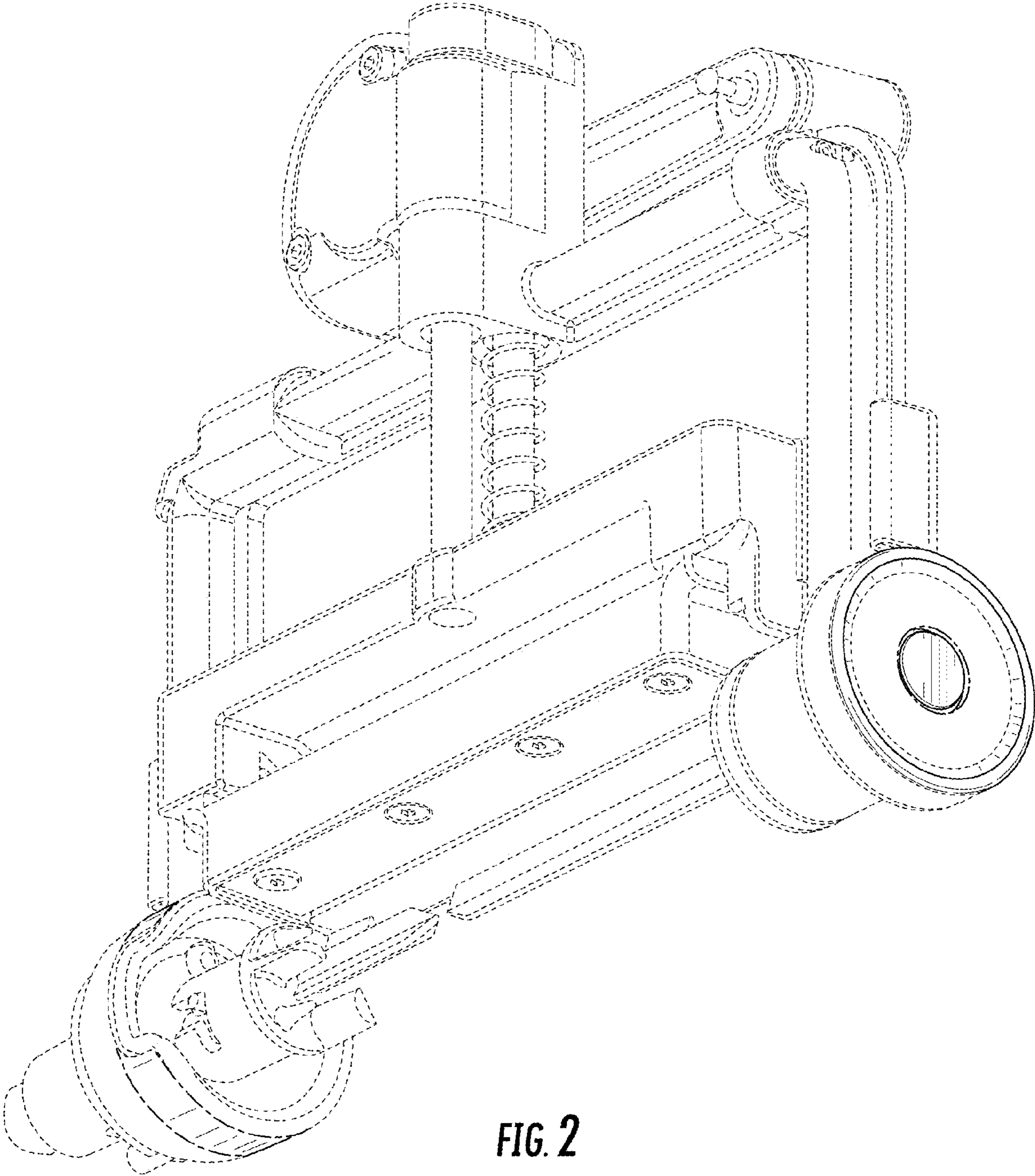

FIG. 2

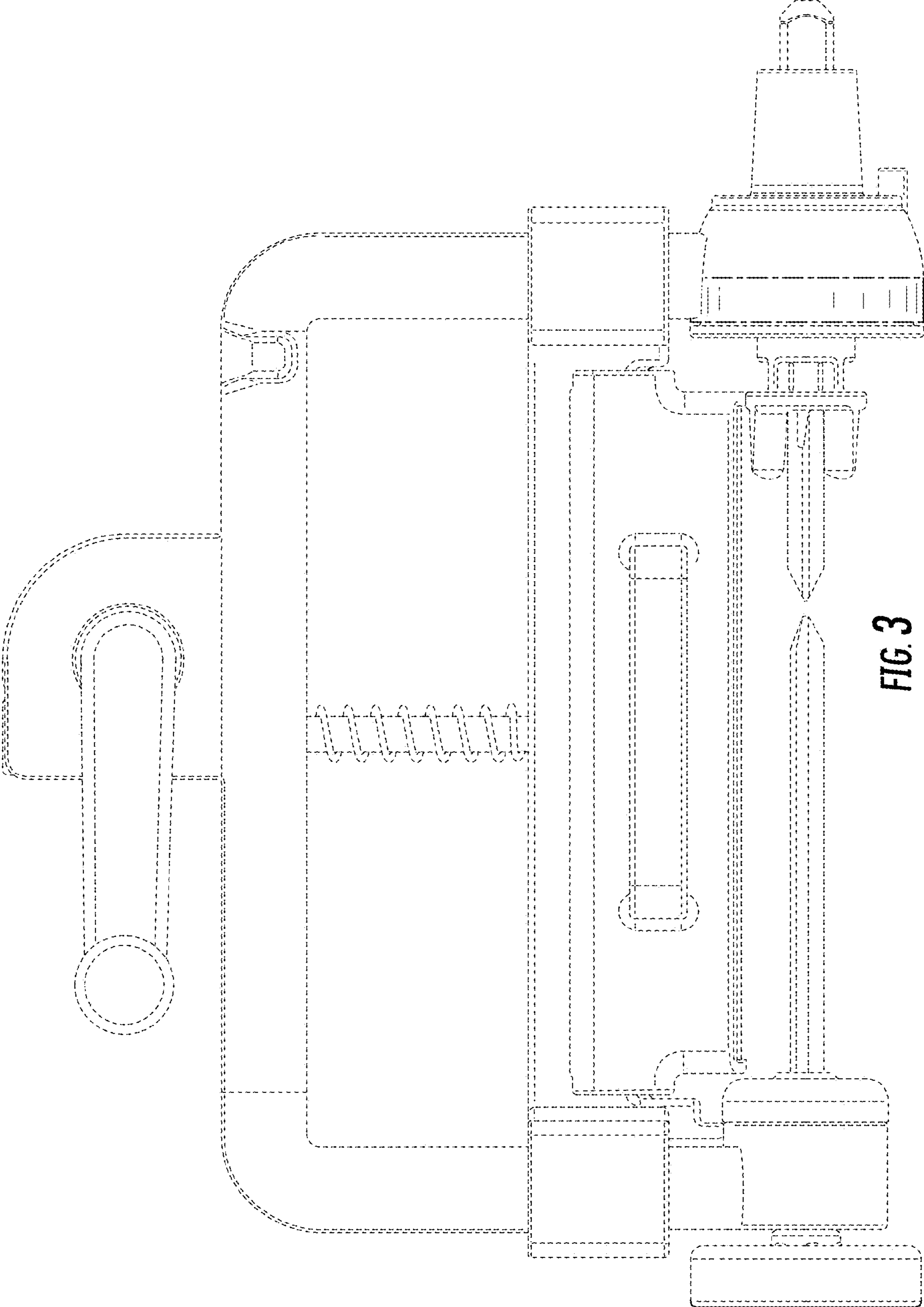

FIG. 3

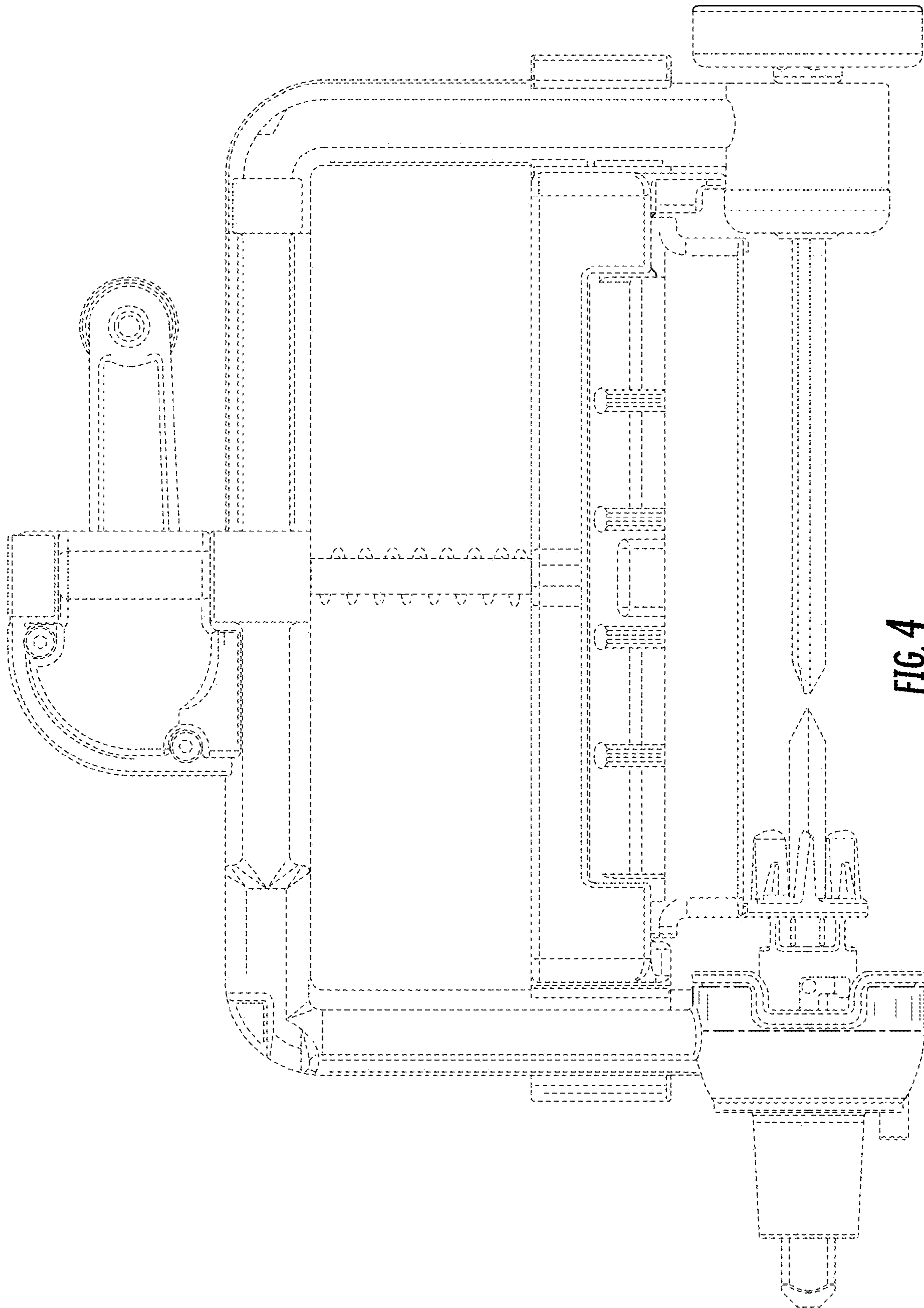

FIG. 4

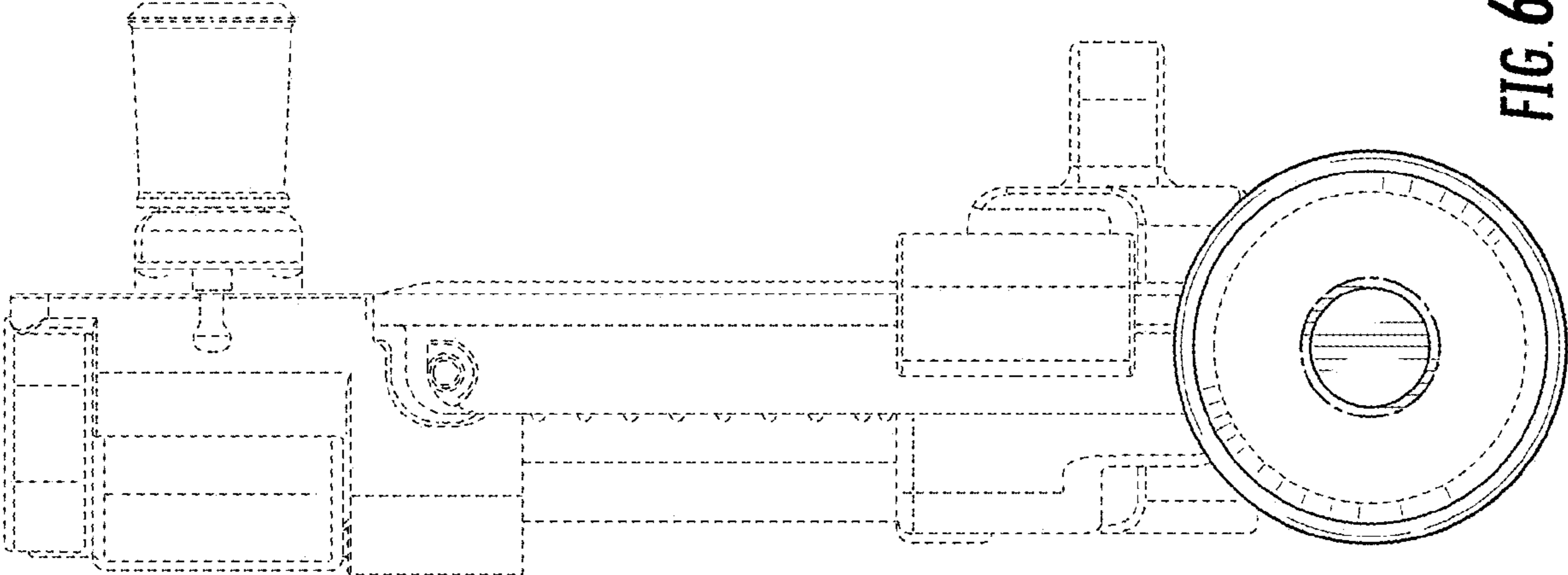

FIG. 6

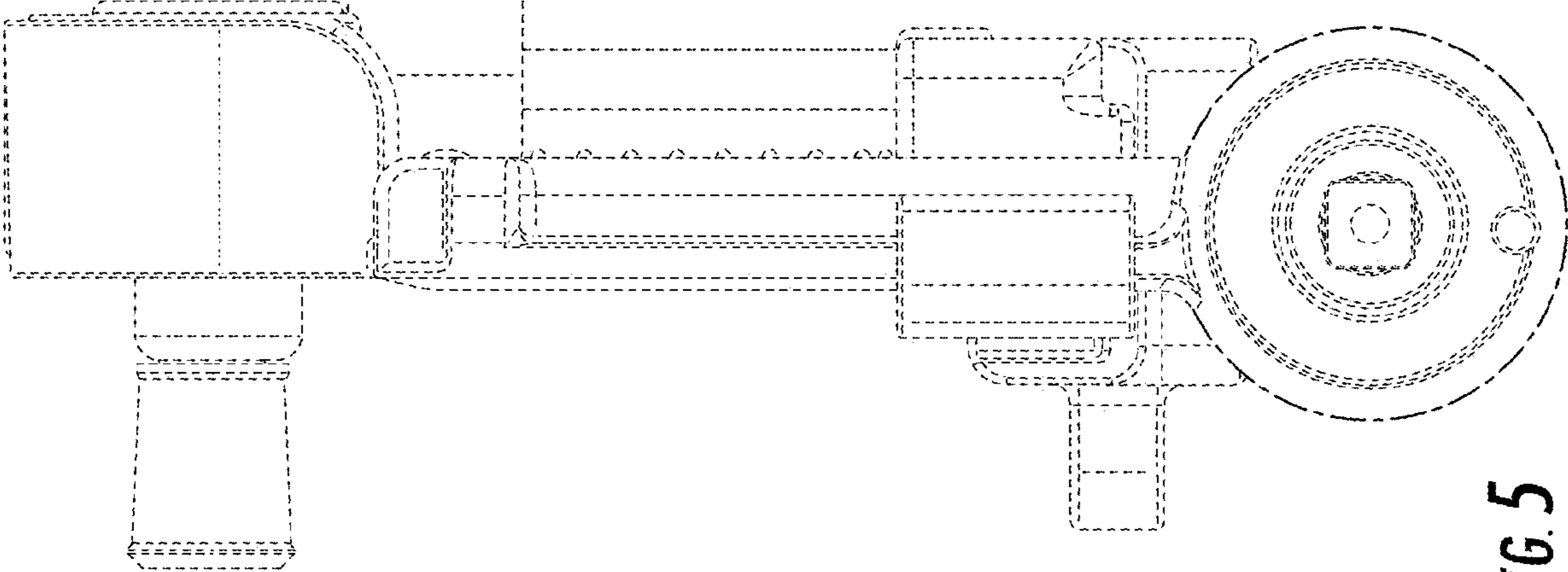

FIG. 5

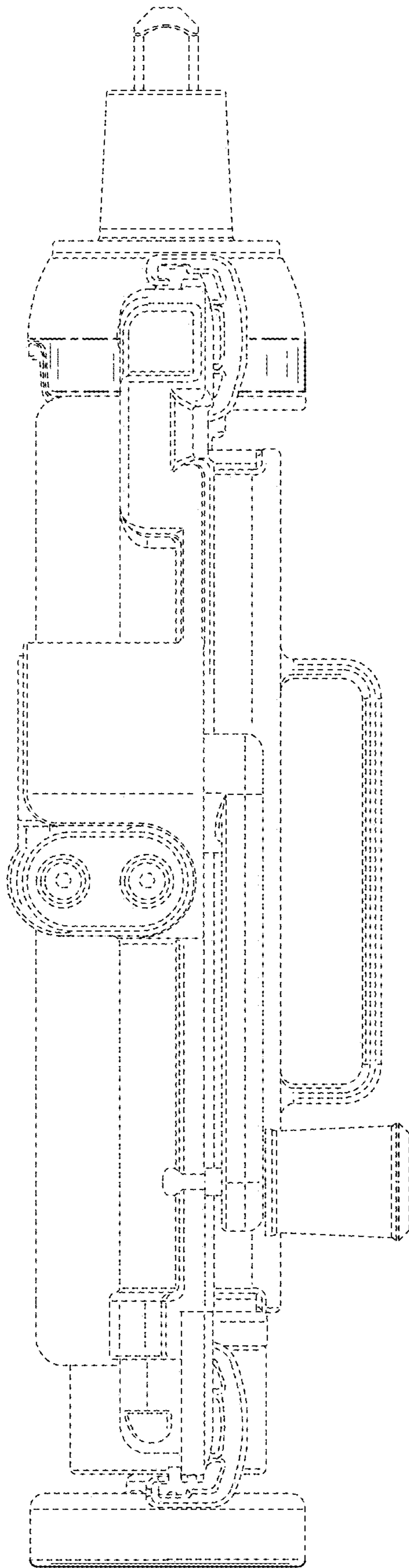

FIG. 7



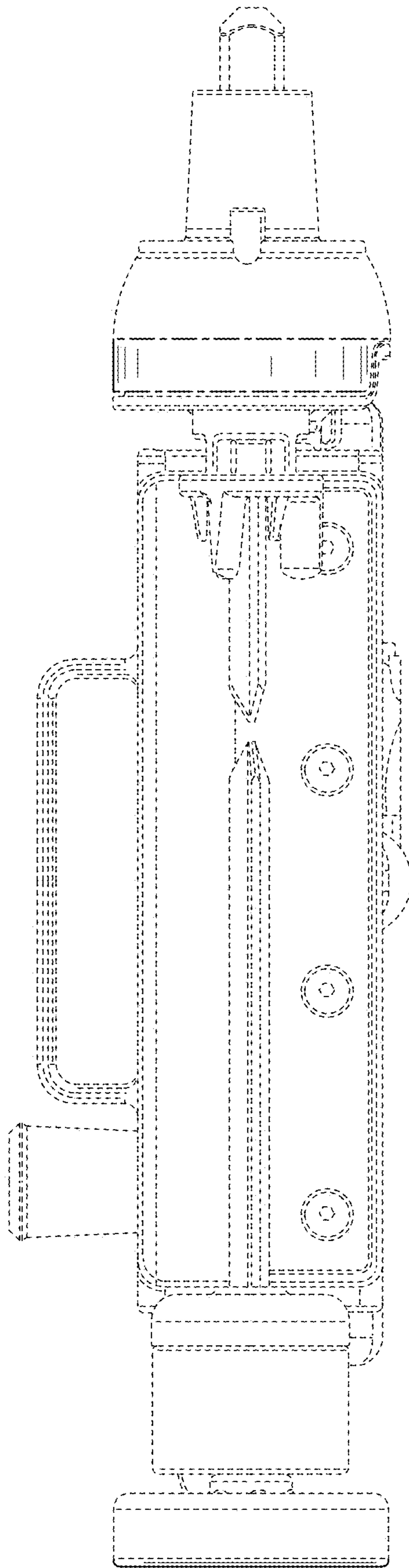

FIG. 8