



US00D986393S

(12) **United States Design Patent** (10) **Patent No.:** **US D986,393 S**
Smith (45) **Date of Patent:** **** May 16, 2023**

(54) **LIQUID TIGHT NON-METALLIC CONNECTOR**
(71) Applicant: **Bridgeport Fittings, LLC**, Stratford, CT (US)
(72) Inventor: **Lawrence J. Smith**, Stamford, CT (US)
(73) Assignee: **BRIDGEPORT FITTINGS, LLC**, Stratford, CT (US)

D709,996 S * 7/2014 Yu D23/262
D712,014 S * 8/2014 Guest D23/262
D716,916 S * 11/2014 Snow D23/262
D733,064 S * 6/2015 Smith D13/149
D754,303 S * 4/2016 Smith D23/259
9,490,619 B2 * 11/2016 Smith H02G 3/088
9,707,386 B2 * 7/2017 Snow A61M 39/0247
9,831,649 B1 * 11/2017 Gretz H02G 3/0683
D958,304 S * 7/2022 Smith D23/262
2014/0117660 A1 * 5/2014 Smith H02G 3/083
285/141.1

(**) Term: **15 Years**
(21) Appl. No.: **29/839,622**
(22) Filed: **May 23, 2022**

Related U.S. Application Data

(62) Division of application No. 29/772,459, filed on Mar. 2, 2021, now Pat. No. Des. 958,304.
(51) **LOC (14) Cl.** **23-01**
(52) **U.S. Cl.**
USPC **D23/262**
(58) **Field of Classification Search**
USPC D23/213, 233-234, 259, 262, 264-265;
D24/127, 129, 112; D13/155
See application file for complete search history.

References Cited

U.S. PATENT DOCUMENTS

6,044,868 A * 4/2000 Gretz F16L 31/02
285/251
7,429,064 B2 * 9/2008 Topolsek H02G 15/04
285/151.1
8,303,000 B2 * 11/2012 Liu F16L 37/42
285/1
D674,058 S * 1/2013 Yu D23/262

OTHER PUBLICATIONS

Bridgeport Connector, Liquid tight, Straight Non-Metallic; Bridgeport Website Copyright Date 2023; Visited Online Mar. 14, 2023; <https://www.bptfittings.com/store/liquid-tight-conduit-fittings/straight-connectors/non-metallic.html> (Year: 2023).*

* cited by examiner

Primary Examiner — Amy C Wierenga

(74) *Attorney, Agent, or Firm* — Ware, Fressola, Maguire & Barber LLP

(57) **CLAIM**

The ornamental design for a liquid tight non-metallic connector, as shown and described.

DESCRIPTION

FIG. 1 is a perspective view of a liquid tight non-metallic connector of my design.
FIG. 2 is a side view thereof.
FIG. 3 is a top view thereof.
FIG. 4 is a bottom view thereof.
FIG. 5 is a top perspective view thereof; and,
FIG. 6 is a bottom perspective view thereof.

1 Claim, 6 Drawing Sheets

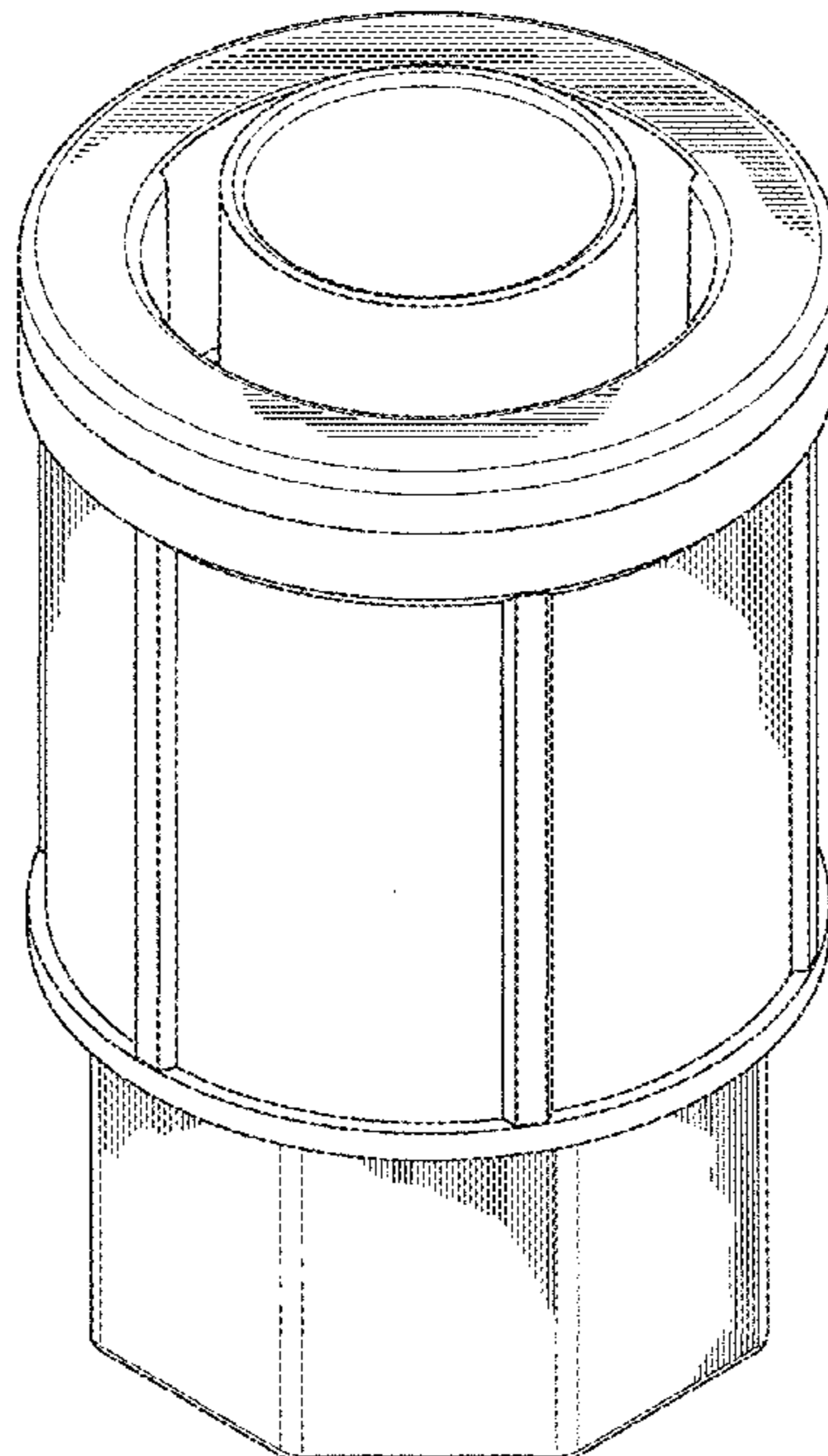

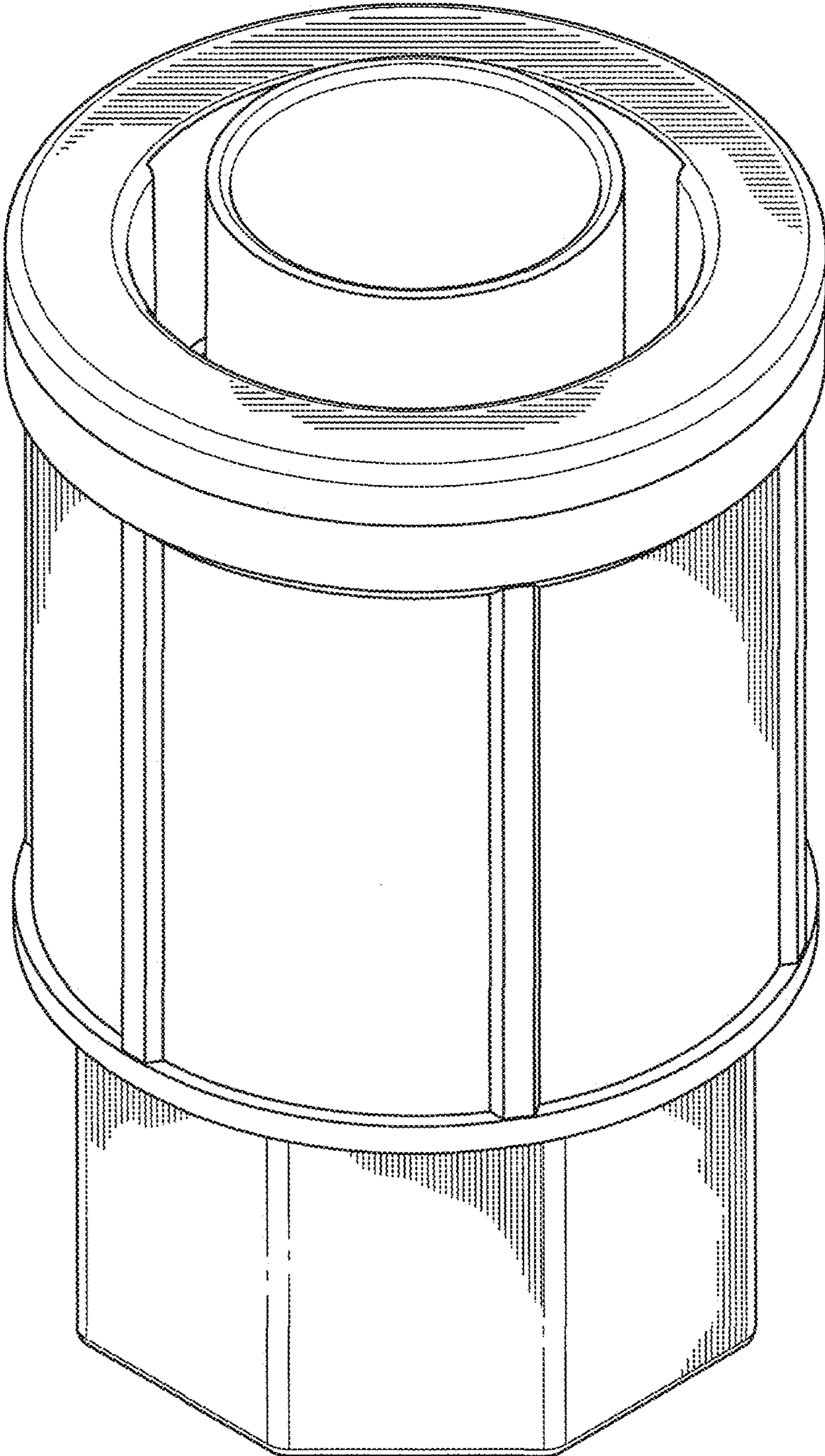

FIG. 1

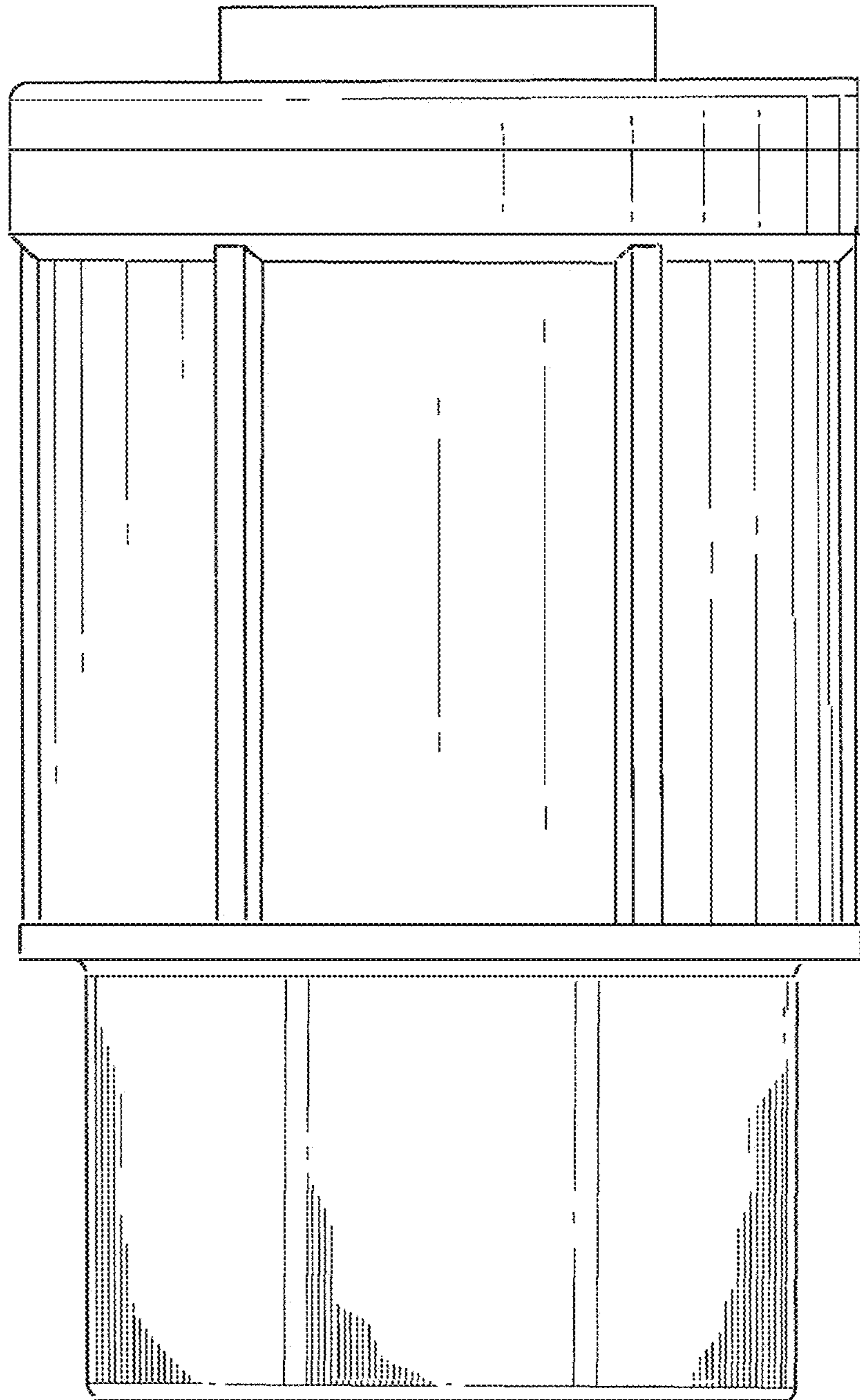

FIG. 2

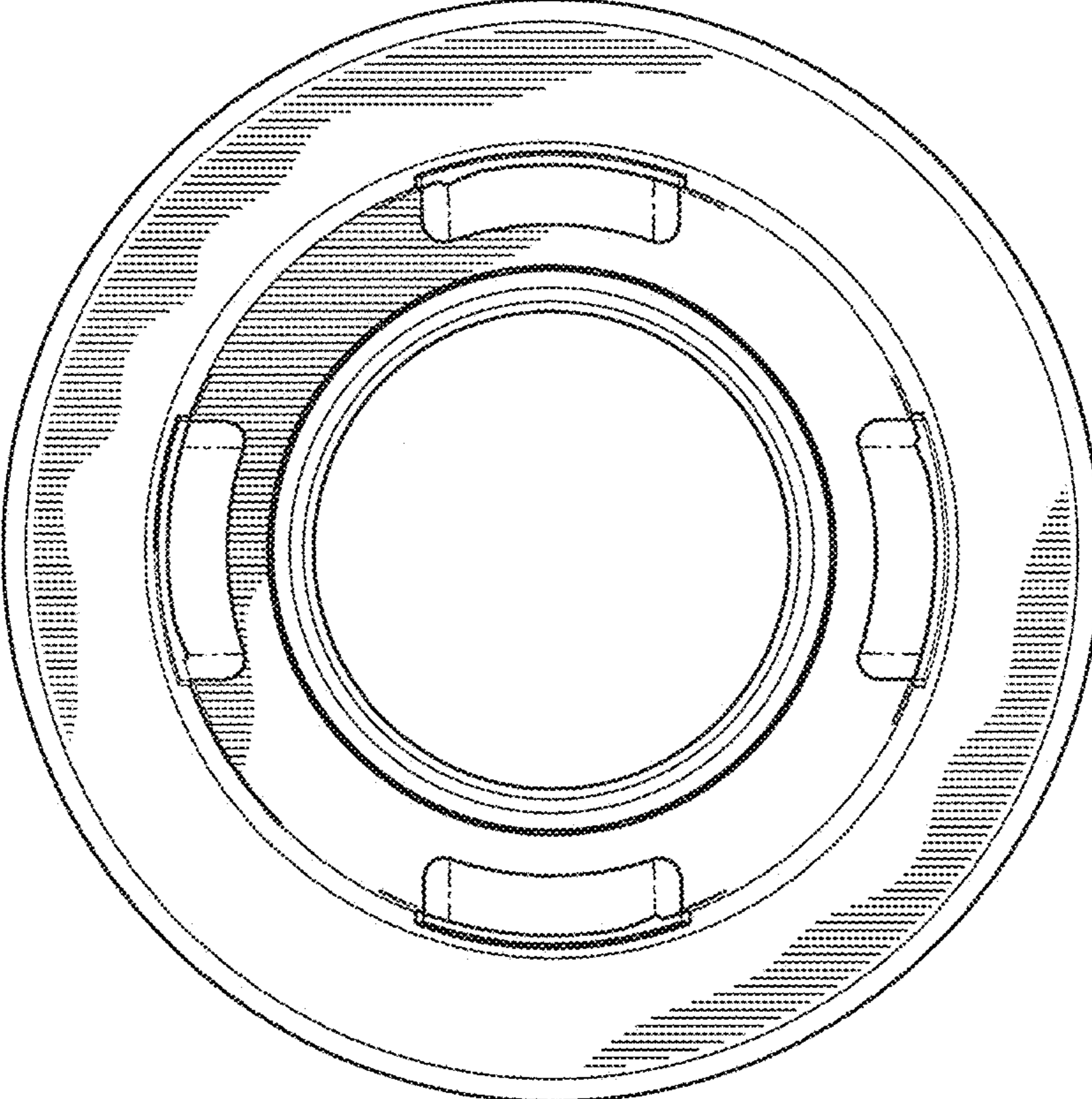

FIG. 3

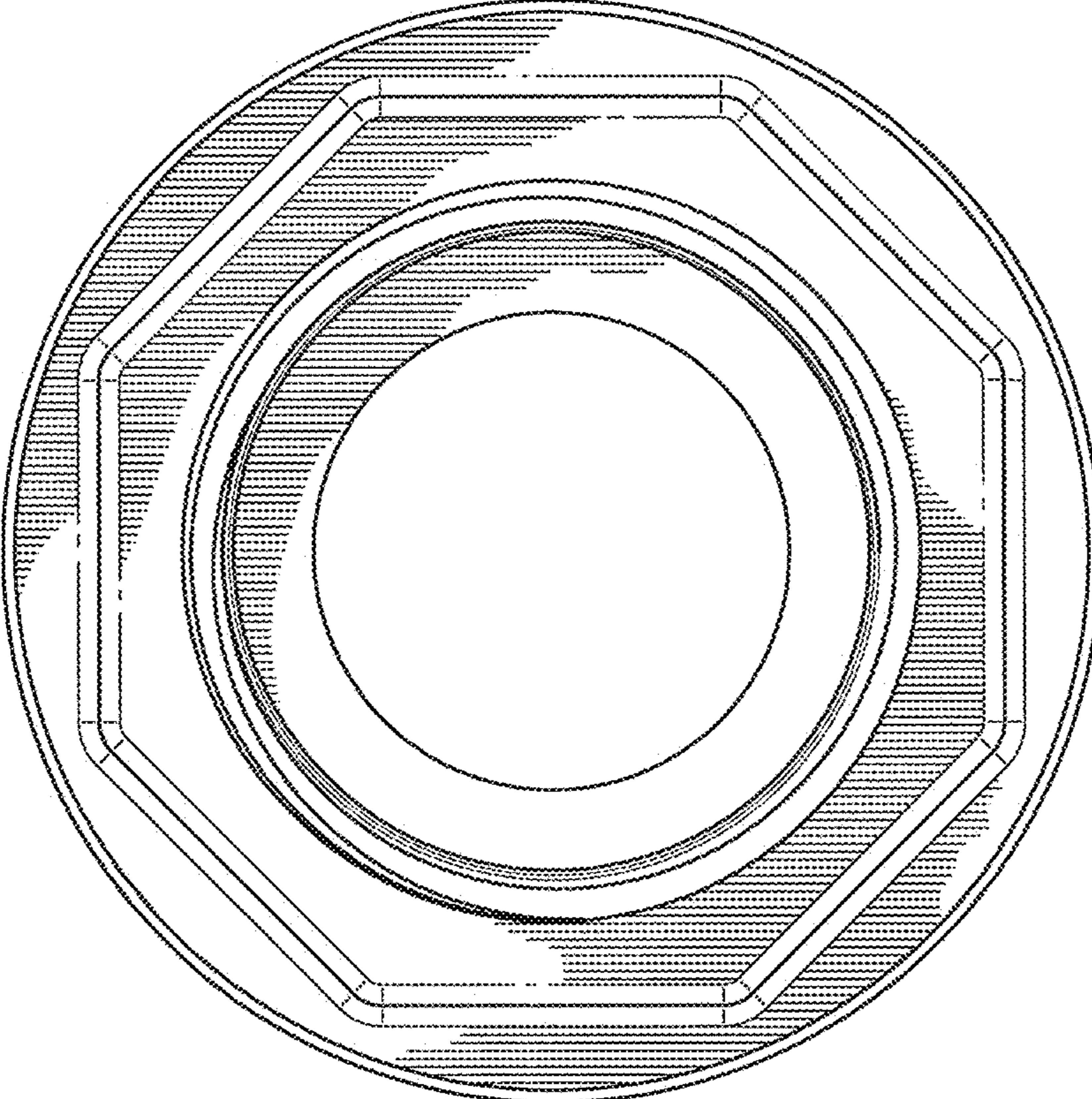

FIG. 4

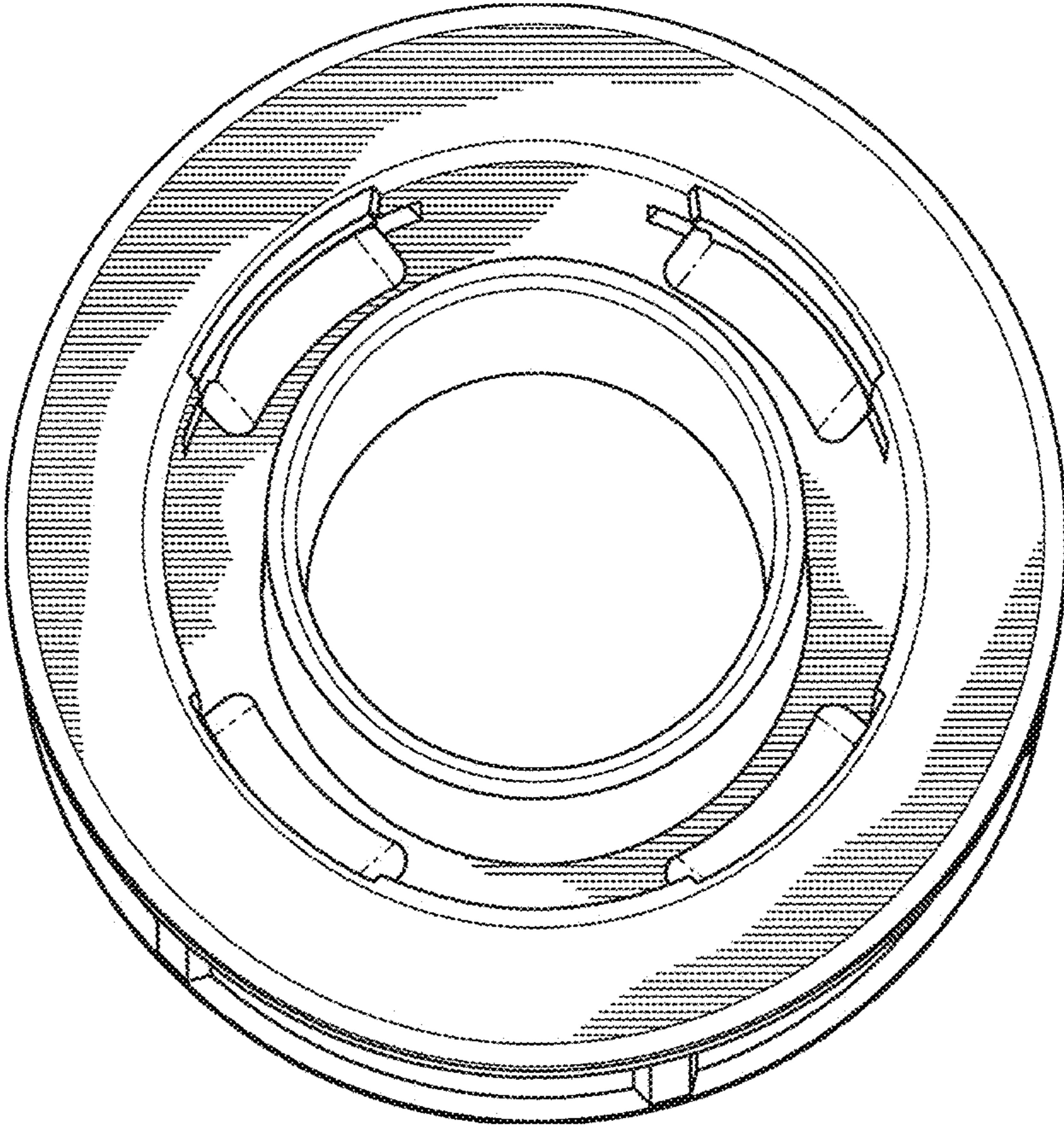

FIG. 5

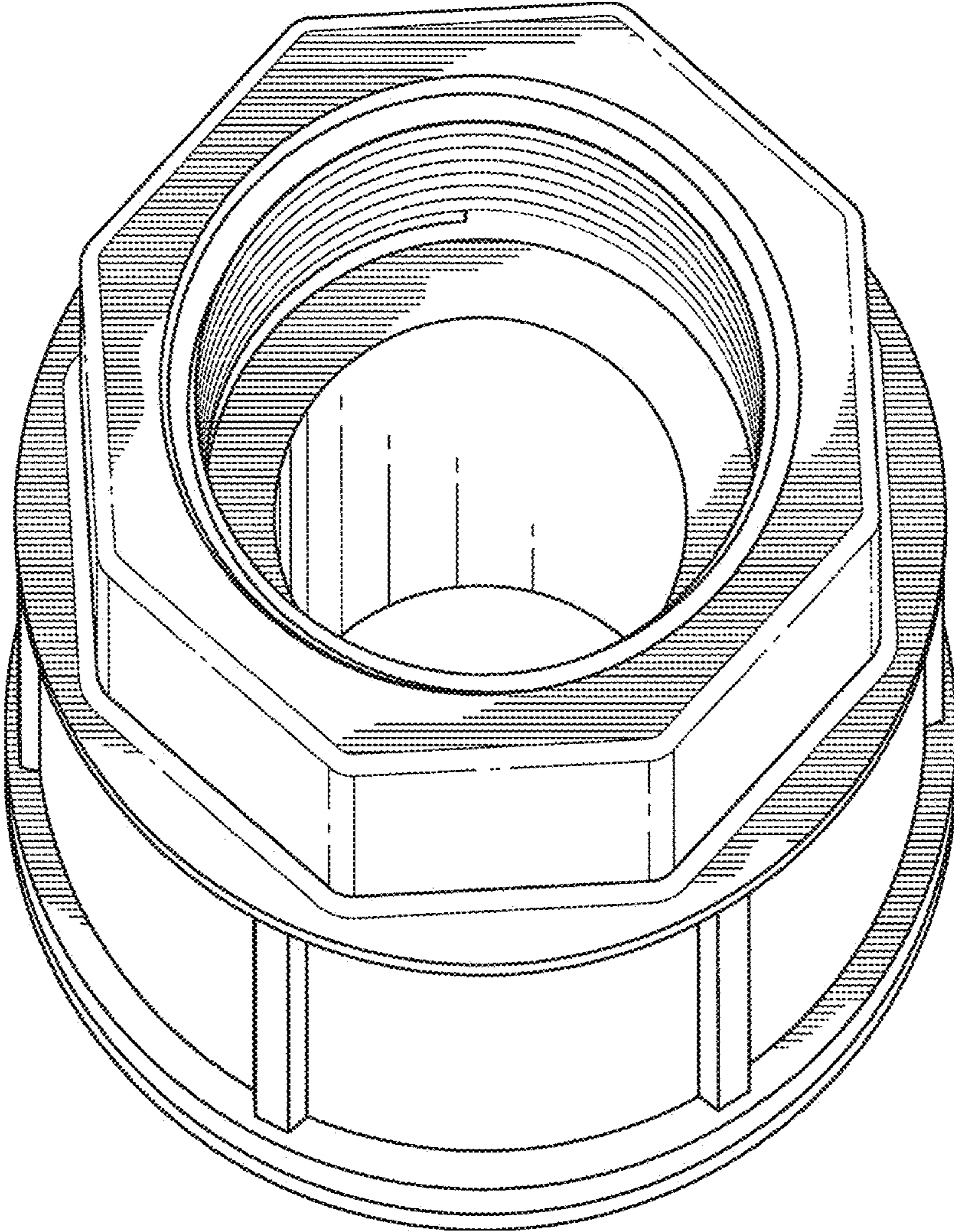

FIG. 6