



US00D986296S

(12) **United States Design Patent**
Takakuwa et al.

(10) **Patent No.:** **US D986,296 S**
(45) **Date of Patent:** **** May 16, 2023**

(54) **BOOSTER REGULATOR**

(71) Applicant: **SMC CORPORATION**, Tokyo (JP)

(72) Inventors: **Youji Takakuwa**, Saitama-ken (JP);
Kengo Monden, Ushiku (JP)

(73) Assignee: **SMC CORPORATION**, Tokyo (JP)

(**) Term: **15 Years**

(21) Appl. No.: **29/762,875**

(22) Filed: **Dec. 18, 2020**

(30) **Foreign Application Priority Data**

Jul. 17, 2020 (CN) 202030391216.1

(51) **LOC (14) Cl.** **15-02**

(52) **U.S. Cl.**
USPC **D15/7**

(58) **Field of Classification Search**
USPC D15/5, 7, 9, 143; D23/235, 249, 499
(Continued)

(56) **References Cited**

U.S. PATENT DOCUMENTS

D317,922 S * 7/1991 Toyoda D15/5
D329,434 S * 9/1992 Toyoda D15/5
(Continued)

FOREIGN PATENT DOCUMENTS

CN 305308373 S 8/2019

OTHER PUBLICATIONS

SCM, Web Catalog Booster Regulators, (site visited Feb. 22, 2023),
SCM world website, URL: <<https://www.smcworld.com/webcatalog/en-jp/modular-frl-units-pressure-control-equipment/booster-regulators/VBA-AS-E/#detail>> (Year: 2023).*

(Continued)

Primary Examiner — Calvin E Vansant

Assistant Examiner — Mark T. Philipps

(74) *Attorney, Agent, or Firm* — Birch, Stewart, Kolasch & Birch, LLP

(57) **CLAIM**

The ornamental design for a booster regulator, as shown and described.

DESCRIPTION

FIG. 1 is a front, top and right side perspective view of a booster regulator showing a first embodiment of our new design;

FIG. 2 is a rear, top and left side perspective view thereof;
FIG. 3 is a front, bottom and left side perspective view thereof;

FIG. 4 is a front view thereof;

FIG. 5 is a rear view thereof;

FIG. 6 is a top plan view thereof;

FIG. 7 is a bottom plan view thereof;

FIG. 8 is a left side view thereof;

FIG. 9 is a right side view thereof;

FIG. 10 is a front, top and right side perspective view of a booster regulator showing a second embodiment of our new design;

FIG. 11 is a rear, top and left side perspective view of FIG. 10;

FIG. 12 is a front, bottom and left side perspective view of FIG. 10;

FIG. 13 is a front view of FIG. 10;

FIG. 14 is a rear view of FIG. 10;

FIG. 15 is a top plan view of FIG. 10;

FIG. 16 is a bottom plan view of FIG. 10;

FIG. 17 is a left side view of FIG. 10;

FIG. 18 is a right side view of FIG. 10;

FIG. 19 is a front, top and right side perspective view of a booster regulator showing a third embodiment of our new design;

FIG. 20 is a rear, top and left side perspective view of FIG. 19;

FIG. 21 is a front, bottom and left side perspective view of FIG. 19;

FIG. 22 is a front view of FIG. 19;

(Continued)

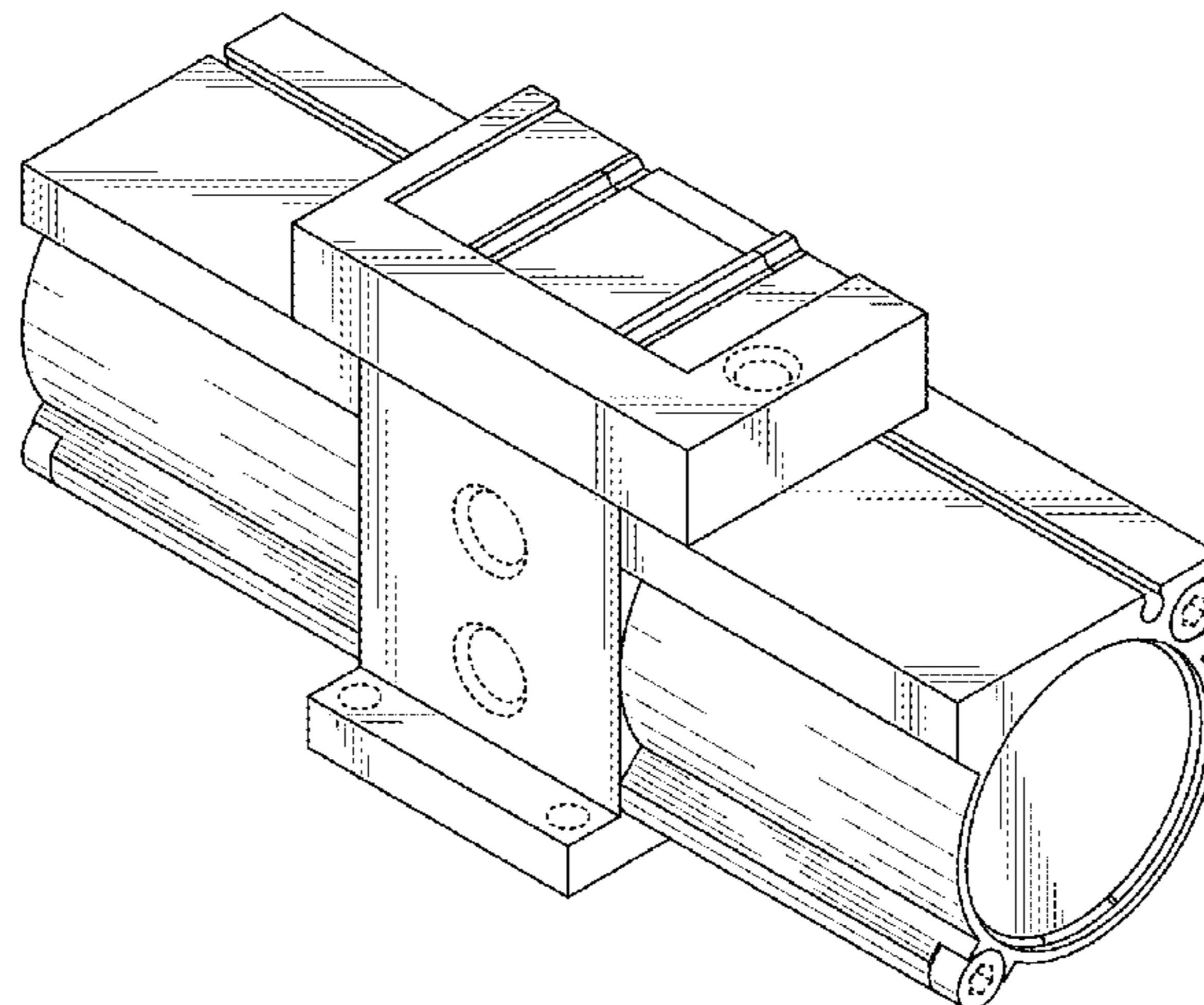

FIG. 23 is a rear view of FIG. 19;
 FIG. 24 is a top plan view of FIG. 19;
 FIG. 25 is a bottom plan view of FIG. 19;
 FIG. 26 is a left side view of FIG. 19; and,
 FIG. 27 is a right side view of FIG. 19.
 The broken lines depict portions of the booster regulator that form no part of the claimed design.

1 Claim, 27 Drawing Sheets

(58) **Field of Classification Search**

CPC F02D 35/023; F02D 41/008; F02D
 2200/0406; F15B 15/149; F15B 15/1428;
 F15B 15/1438; F15B 15/1447; F15B
 15/1457; F15B 15/1461

See application file for complete search history.

(56)

References Cited

U.S. PATENT DOCUMENTS

D332,268 S * 1/1993 Cook D15/7
 D365,352 S * 12/1995 Miyamoto D15/199
 D373,363 S * 9/1996 Miyachi D15/7
 D380,217 S * 6/1997 Jermeay D15/7
 D399,830 S * 10/1998 Nagai D13/199

D413,129 S * 8/1999 Nagai D15/199
 D422,075 S * 3/2000 Hakuta D23/499
 D429,737 S * 8/2000 Kuan D15/7
 D441,768 S * 5/2001 Nagai D15/7
 D554,164 S * 10/2007 Naruse D15/143
 D572,272 S 7/2008 Igarashi et al.
 D626,968 S 11/2010 Iwata et al.
 D629,494 S 12/2010 Sato
 D689,525 S * 9/2013 Peschel D15/7
 D700,625 S * 3/2014 Iwagoshi D15/7
 D704,238 S * 5/2014 Fukano D15/199
 D792,916 S * 7/2017 Kobayashi D15/148
 D846,076 S * 4/2019 Ezura D23/235
 D888,774 S * 6/2020 Asahara D15/7
 D898,774 S * 10/2020 Monden D15/7
 D900,166 S * 10/2020 Nemoto D15/7
 D900,167 S * 10/2020 Monden D15/7
 D900,168 S * 10/2020 Monden D15/7
 D951,999 S * 5/2022 Asahara D15/7
 2021/0301838 A1 * 9/2021 Takakuwa F04B 9/133

OTHER PUBLICATIONS

SCM Corporation, VBA11A-F02 Booster Regulator, (first available Sep. 27, 2021), Amazon.com, URL:<<https://www.amazon.com/SMC-CORPORATION-VBA11A-F02-Regulator-Increase/dp/B09H6VMY6K>> (Year: 2021).*

* cited by examiner

FIG. 1

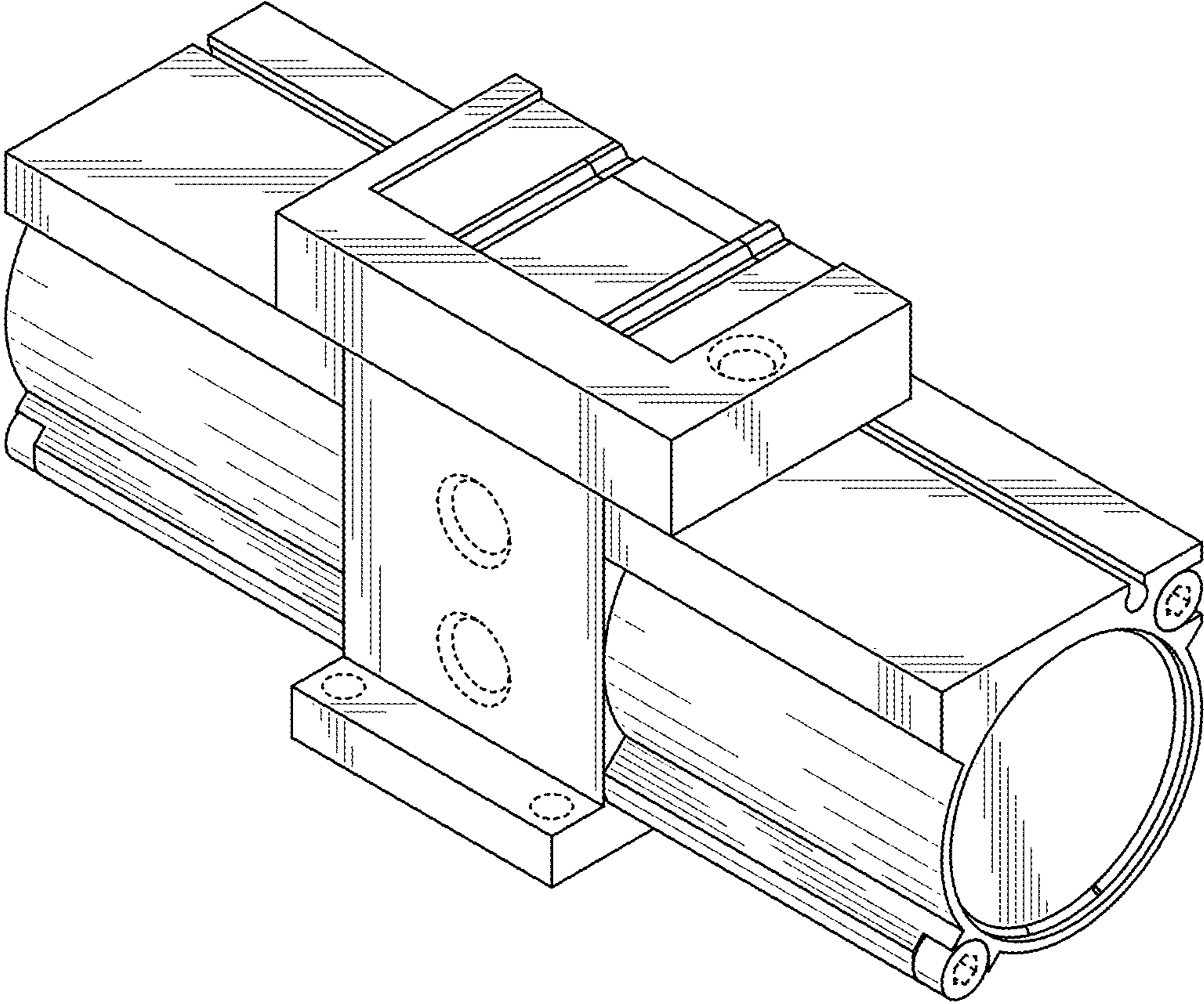

FIG. 2

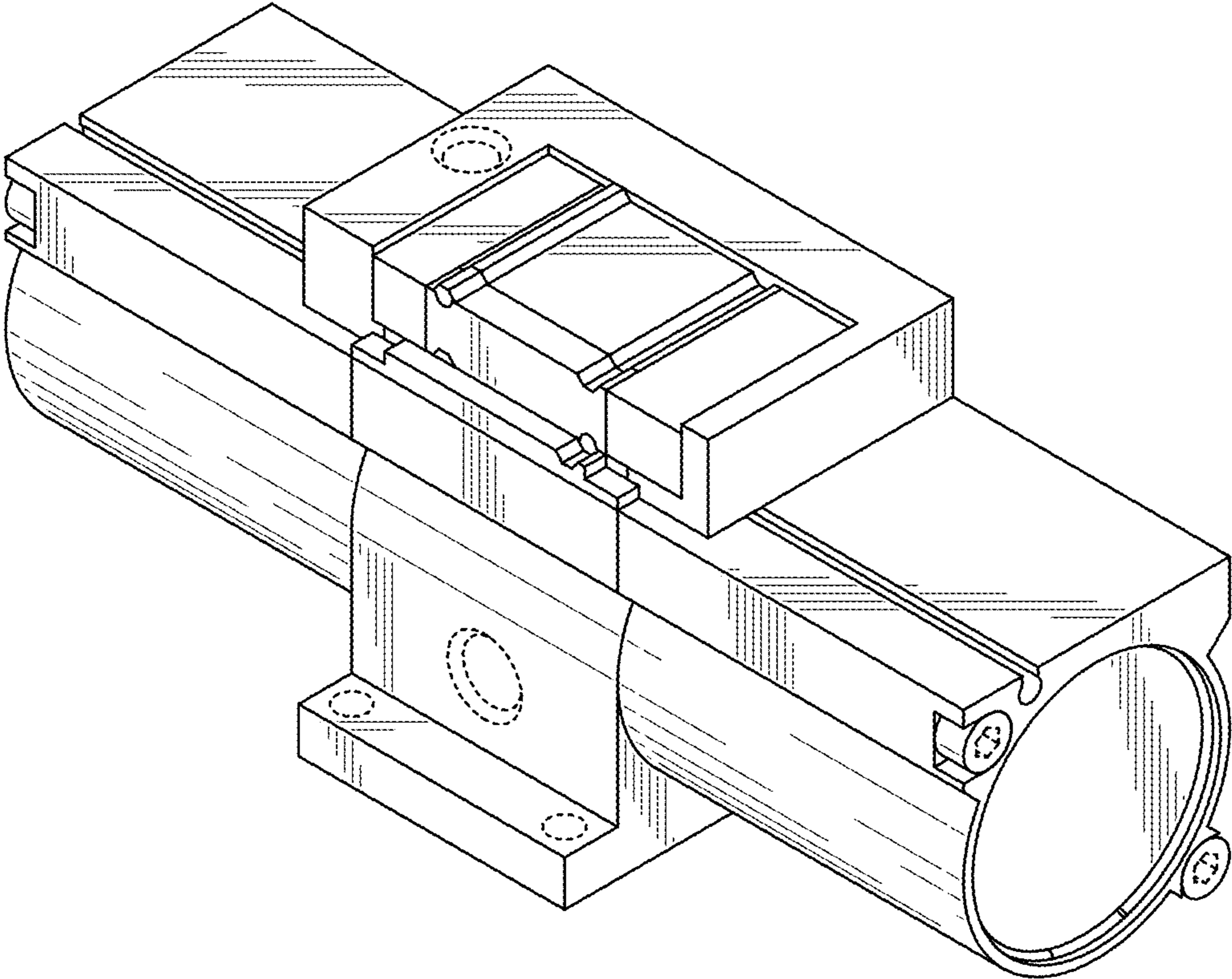

FIG. 3

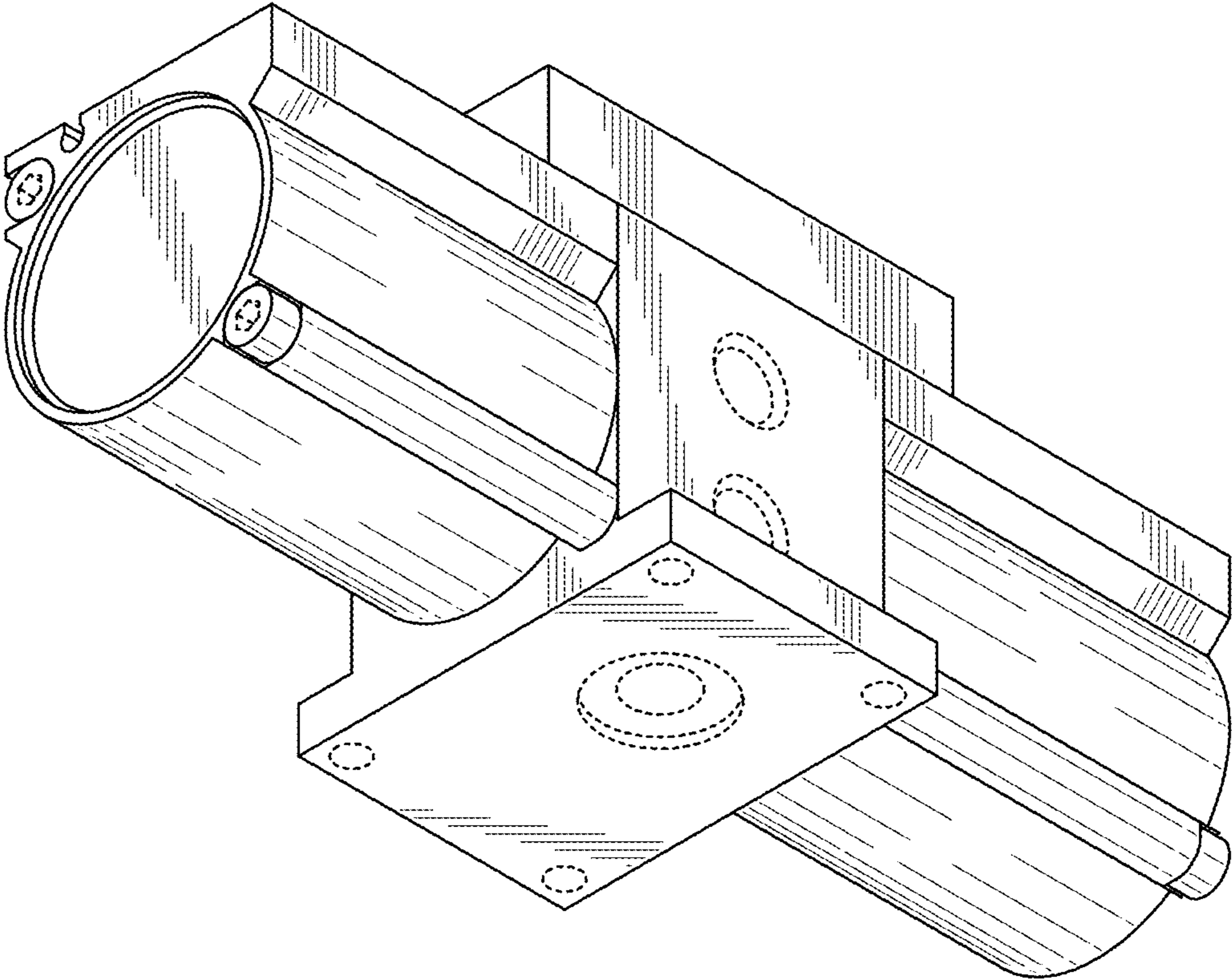

FIG. 4

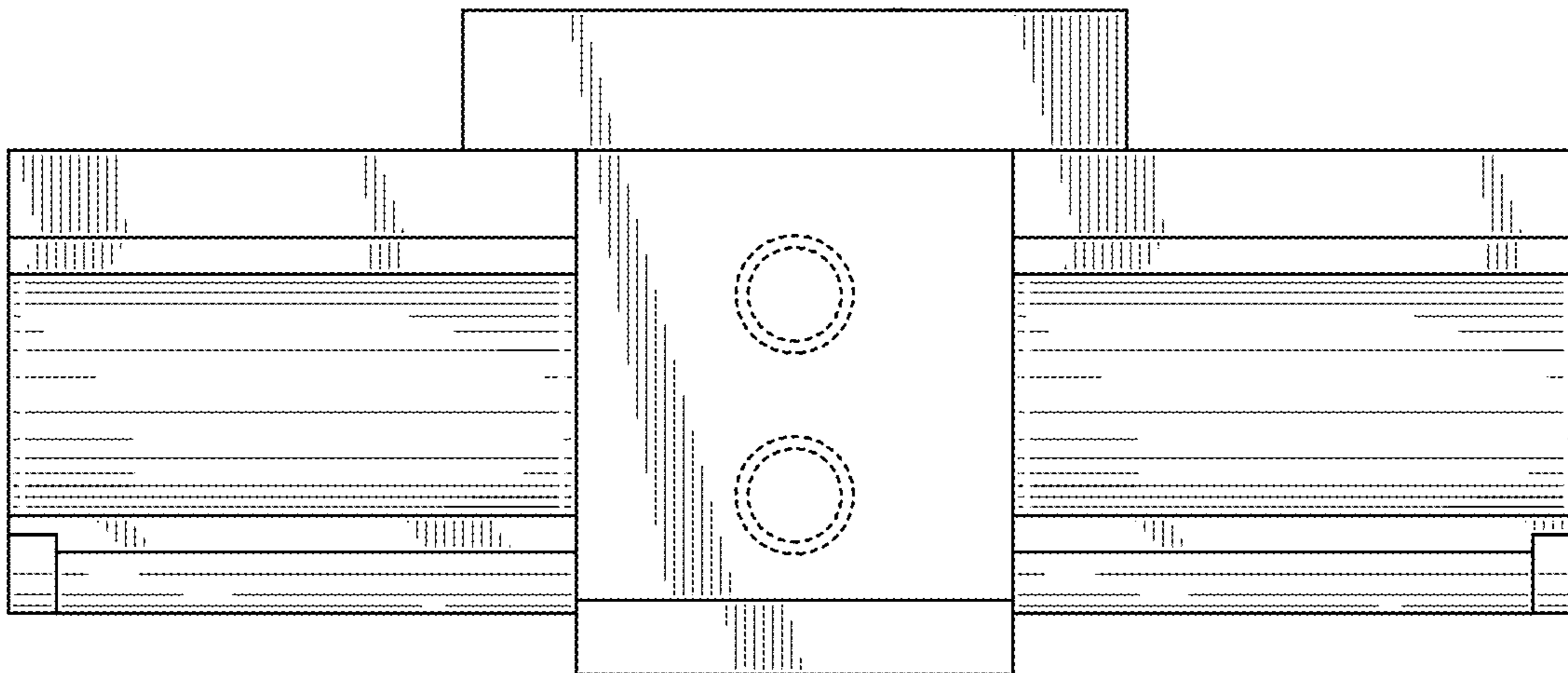

FIG. 5

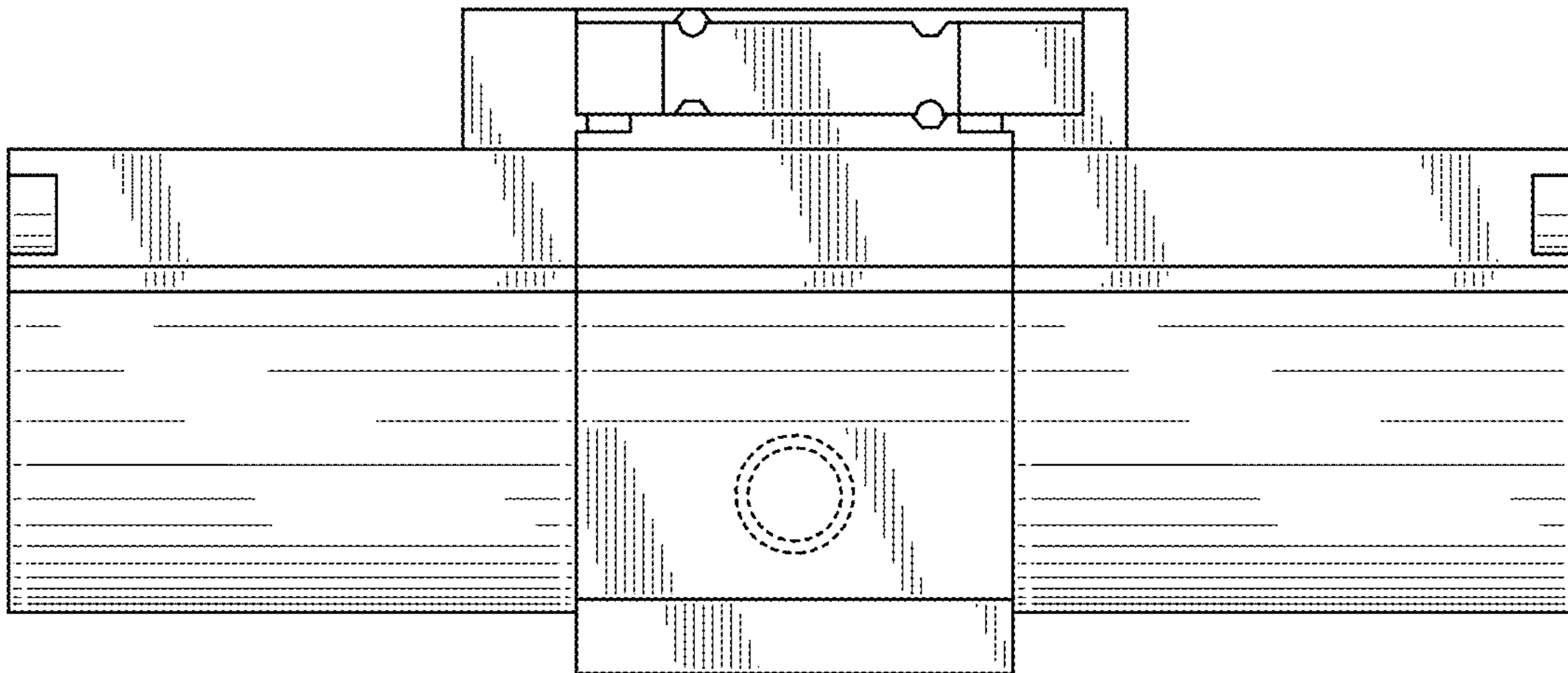

FIG. 6

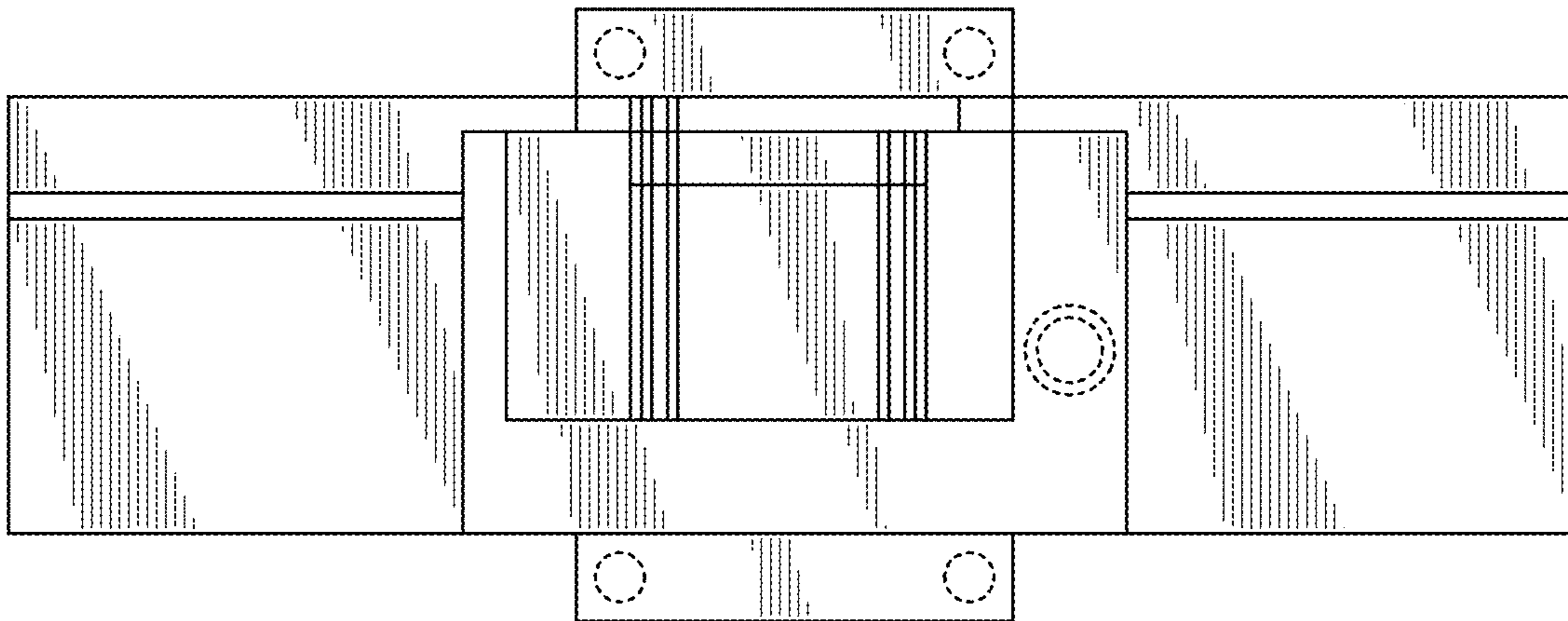

FIG. 7

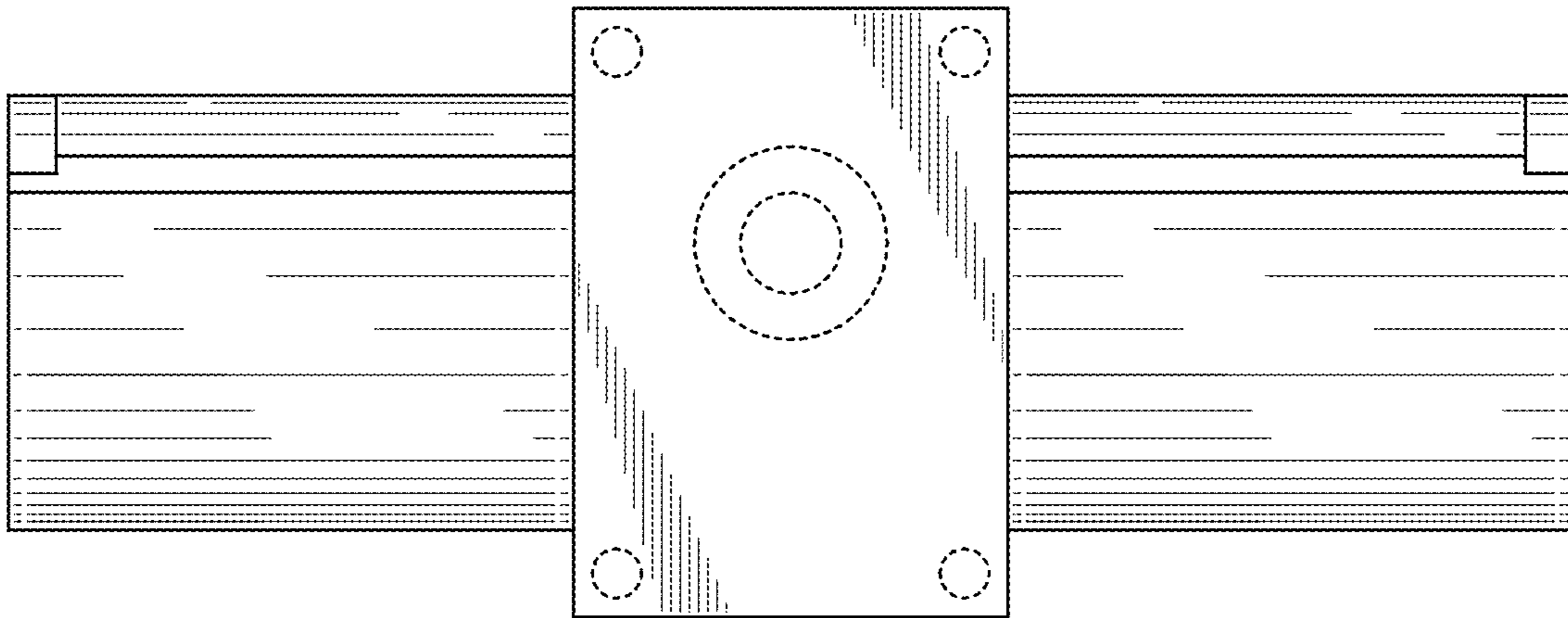

FIG. 8

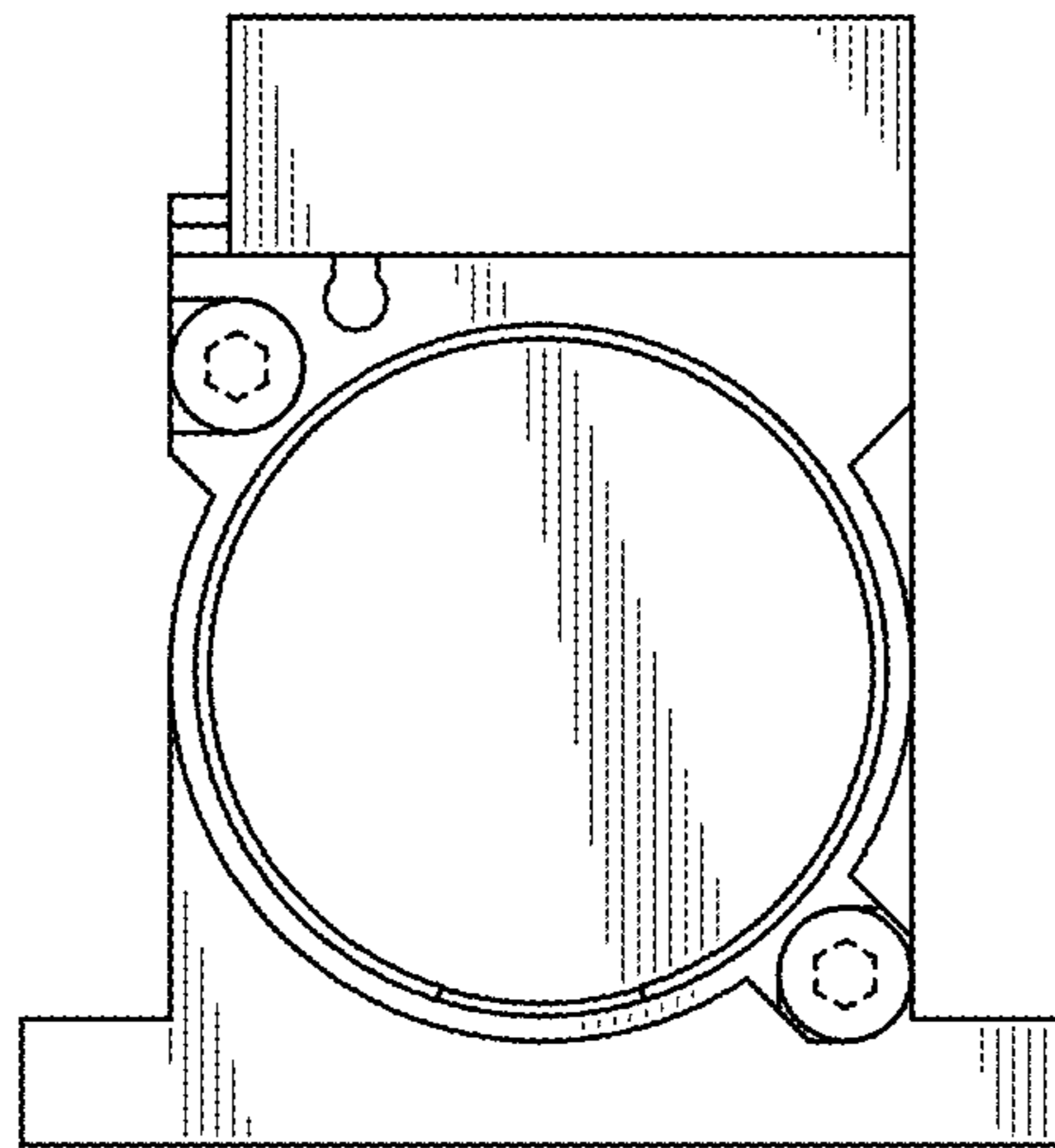

FIG. 9

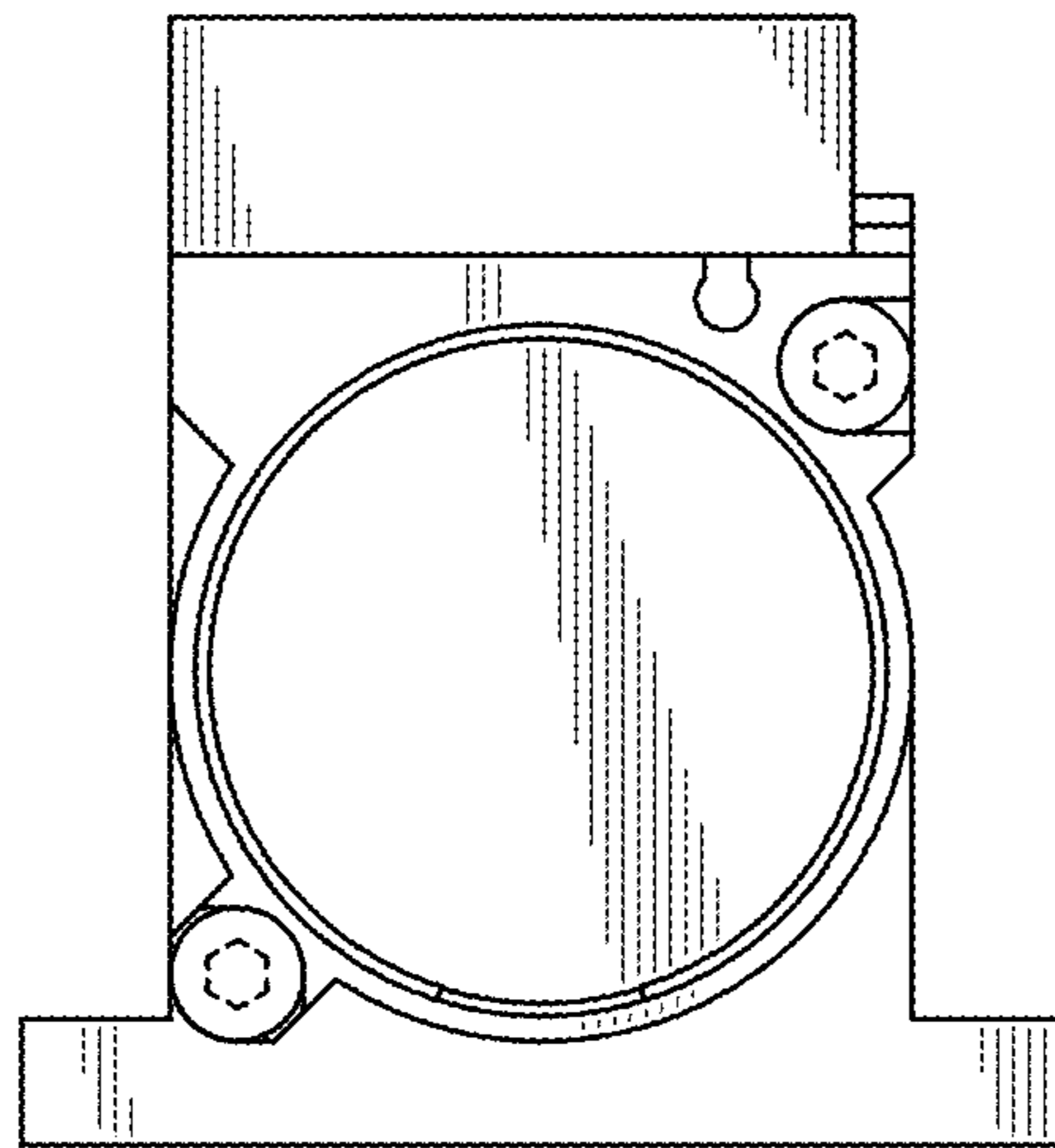

FIG. 10

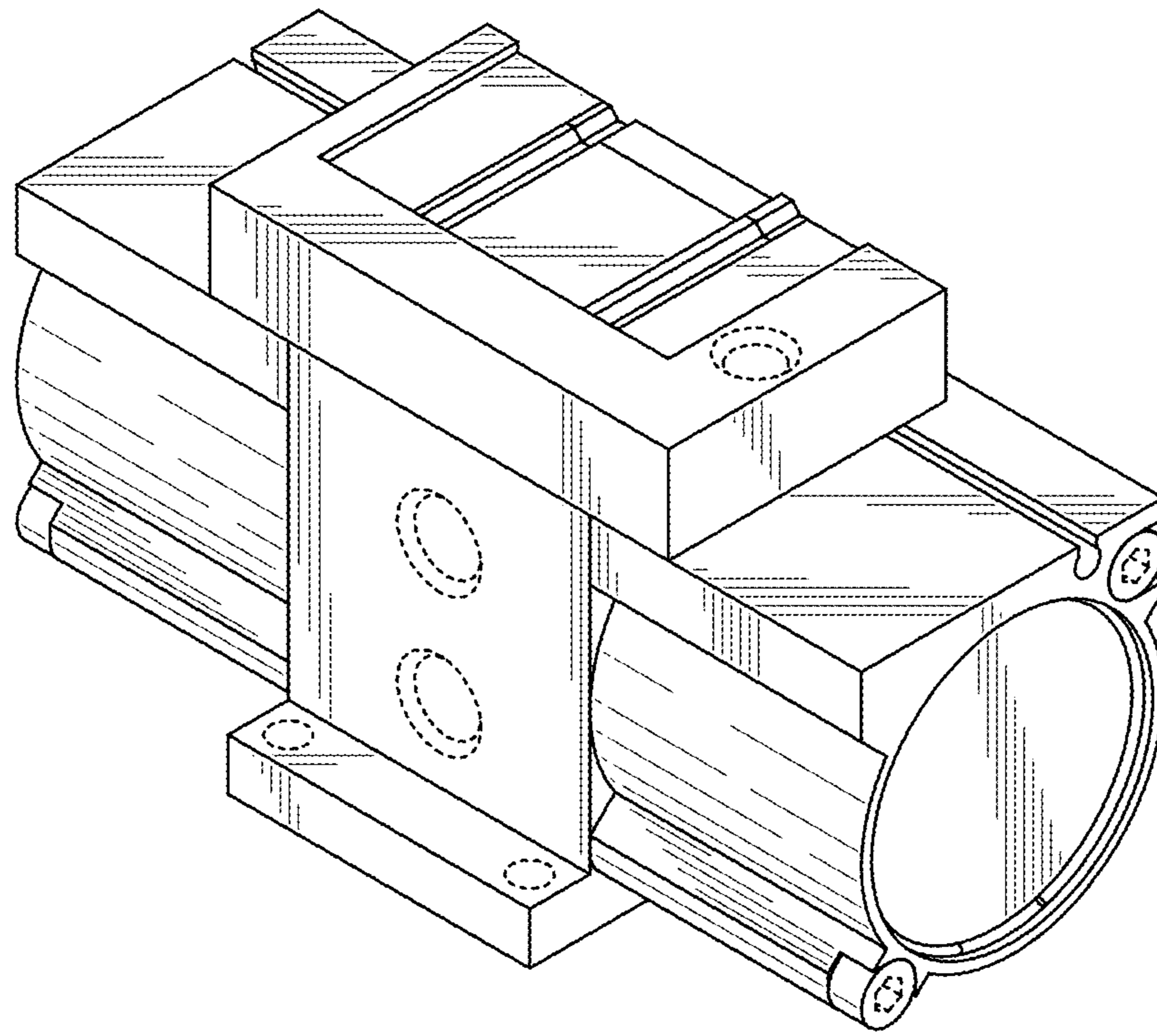

FIG. 11

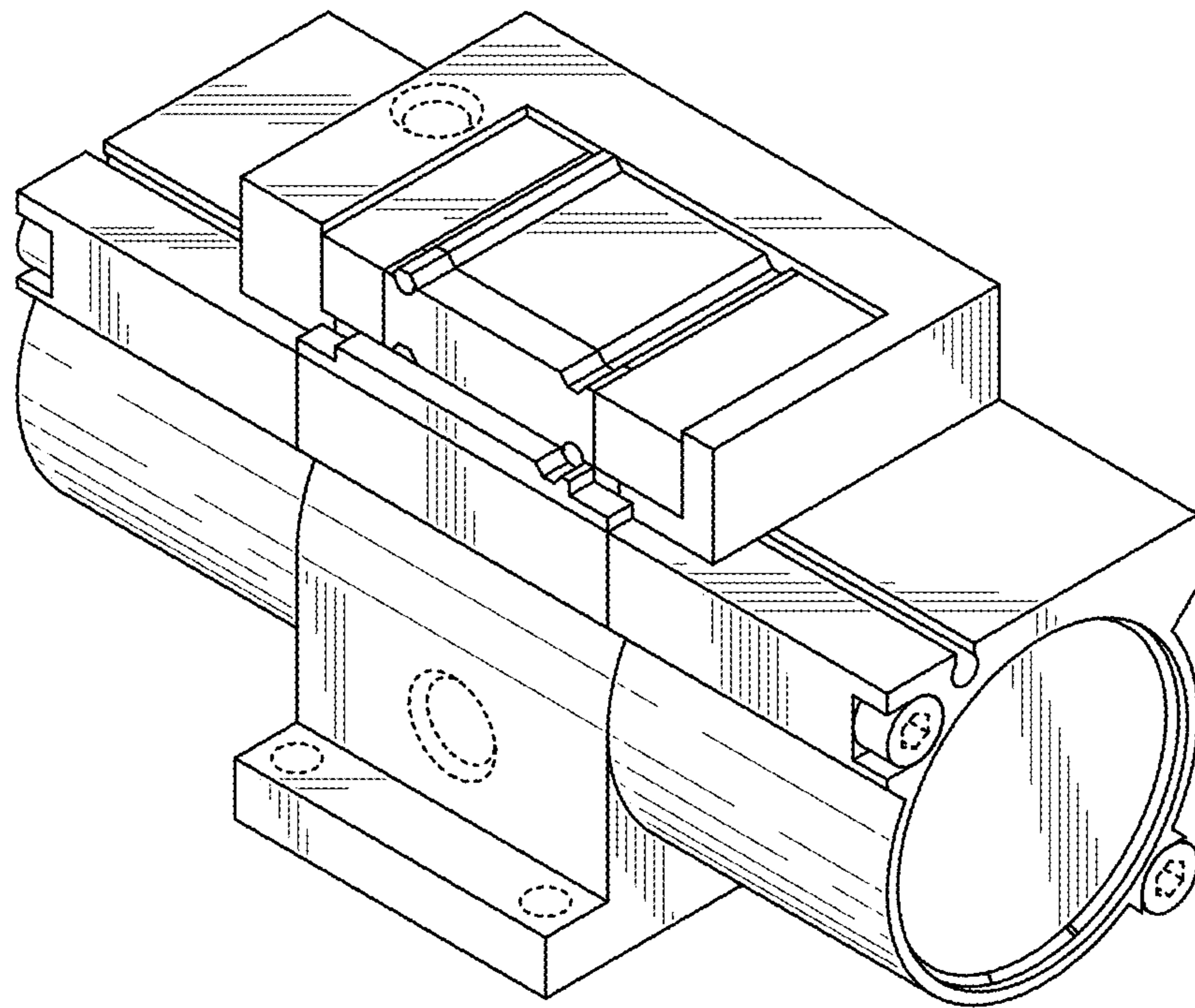

FIG. 12

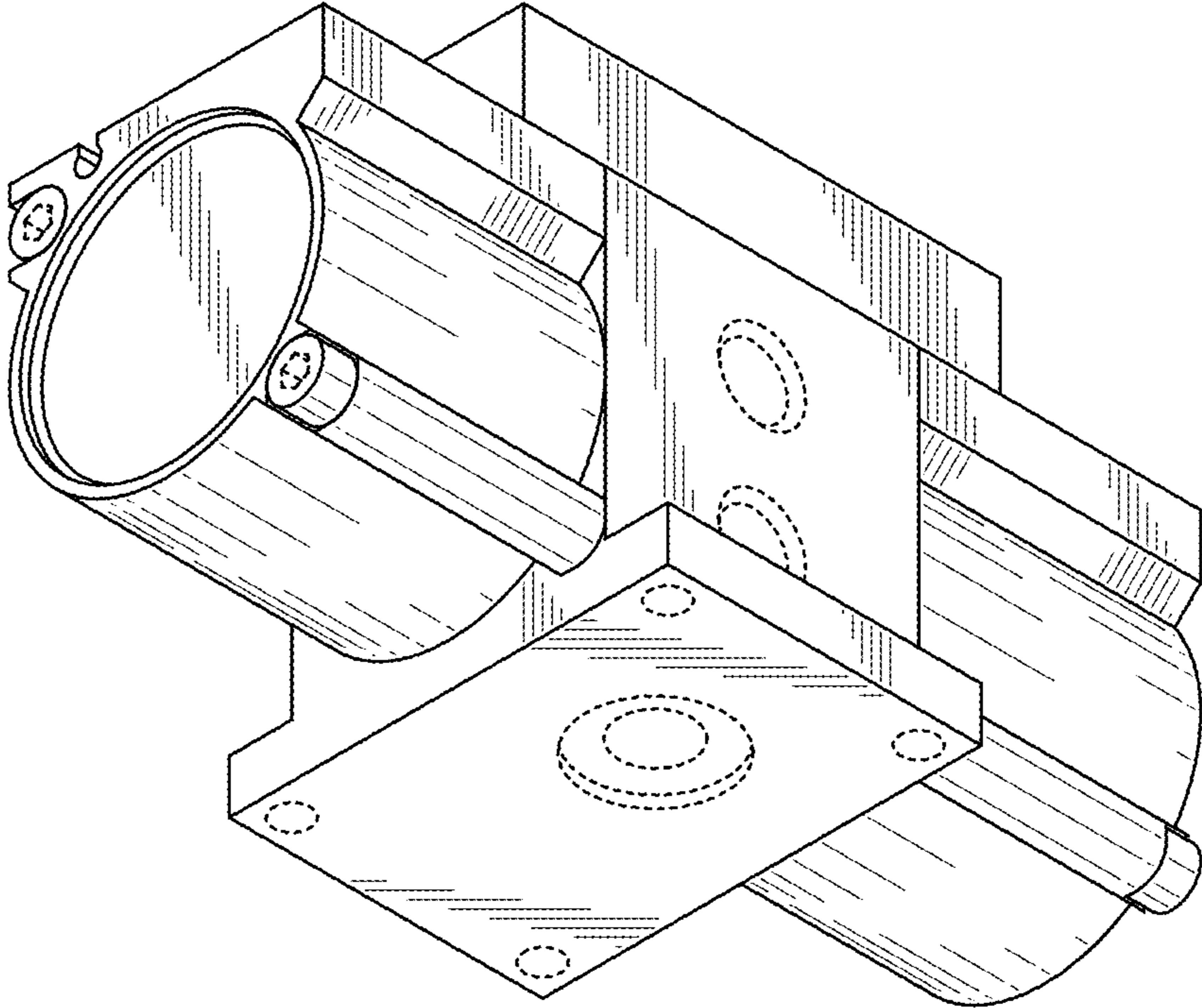

FIG. 13

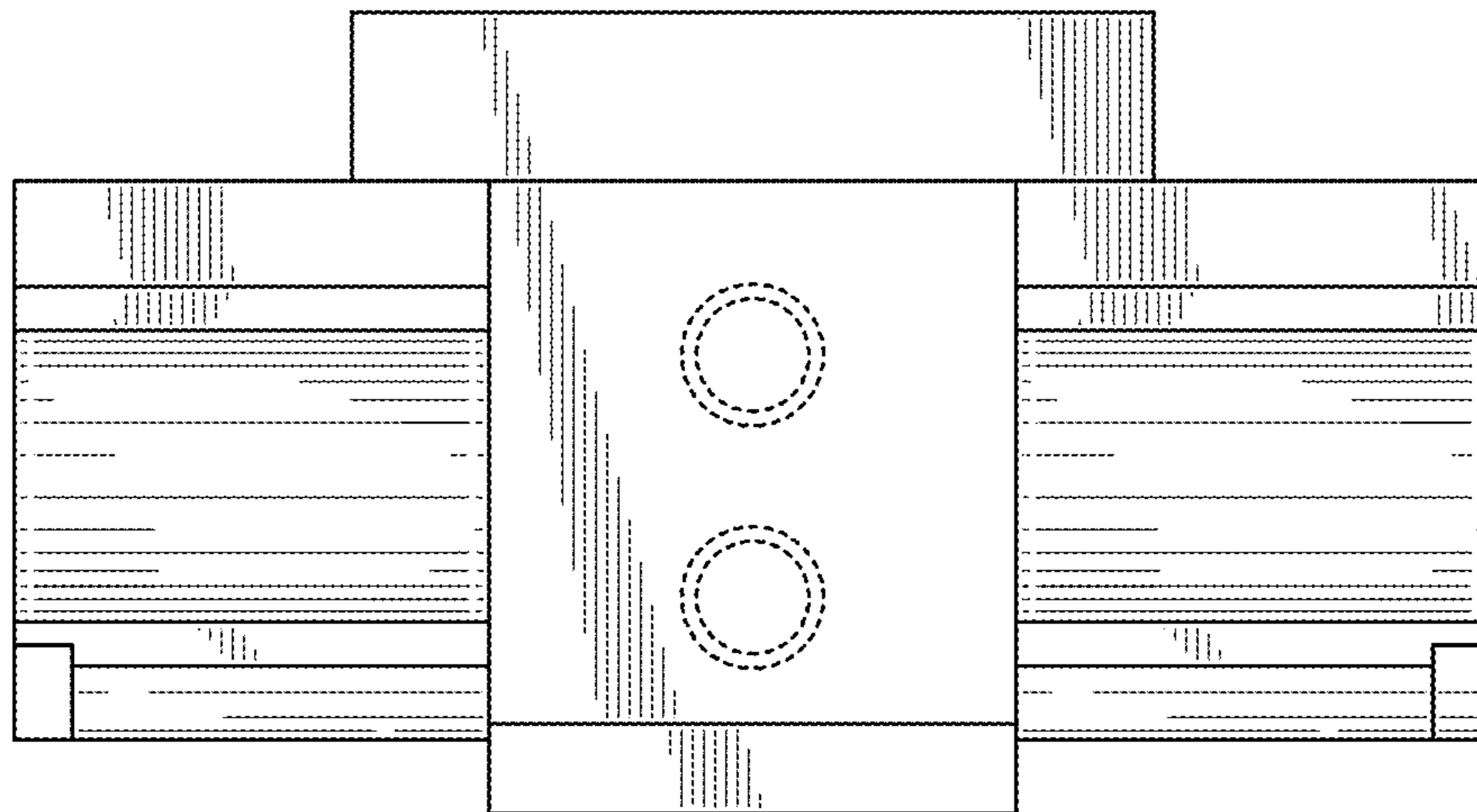

FIG. 14

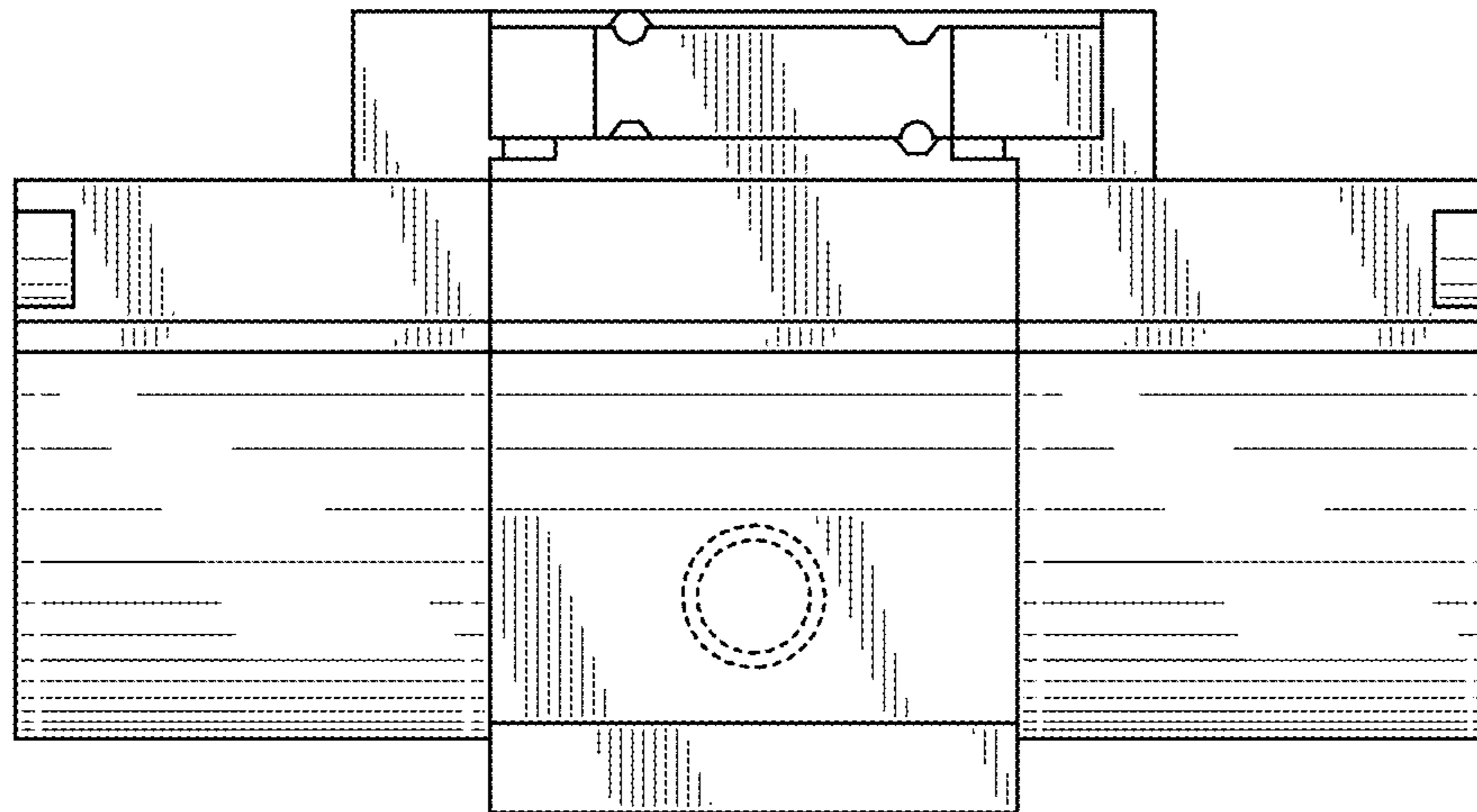

FIG. 15

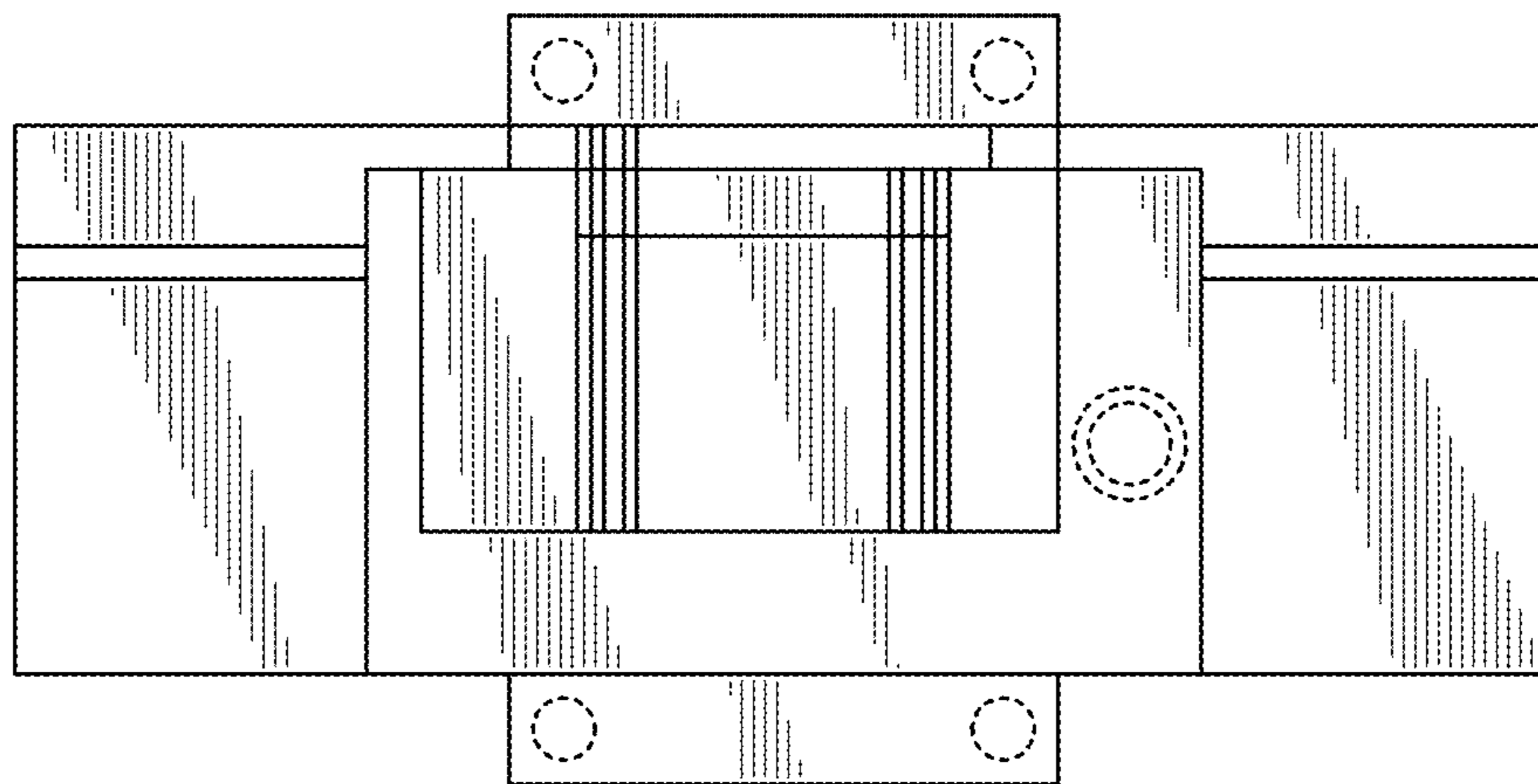

FIG. 16

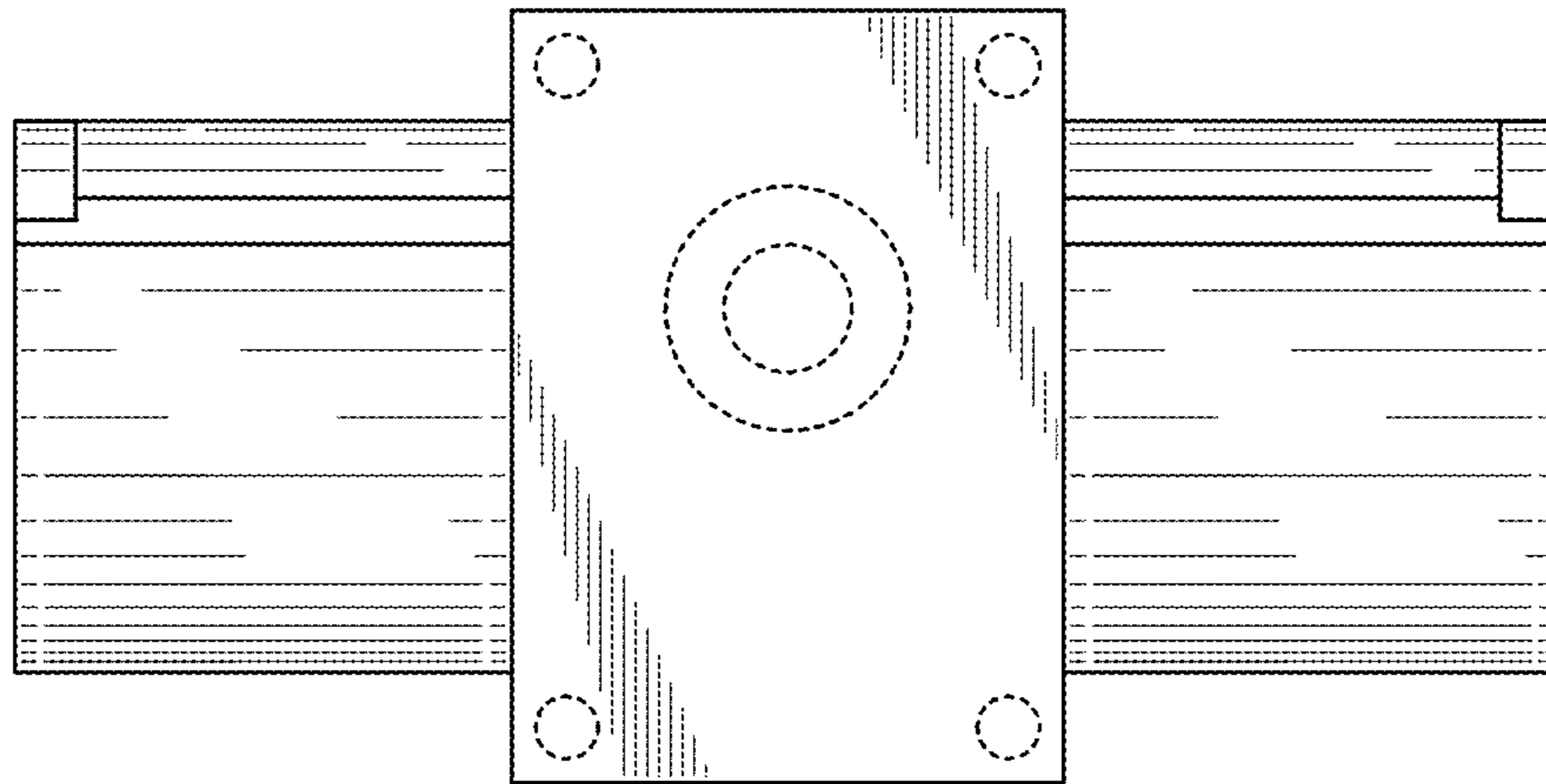

FIG. 17

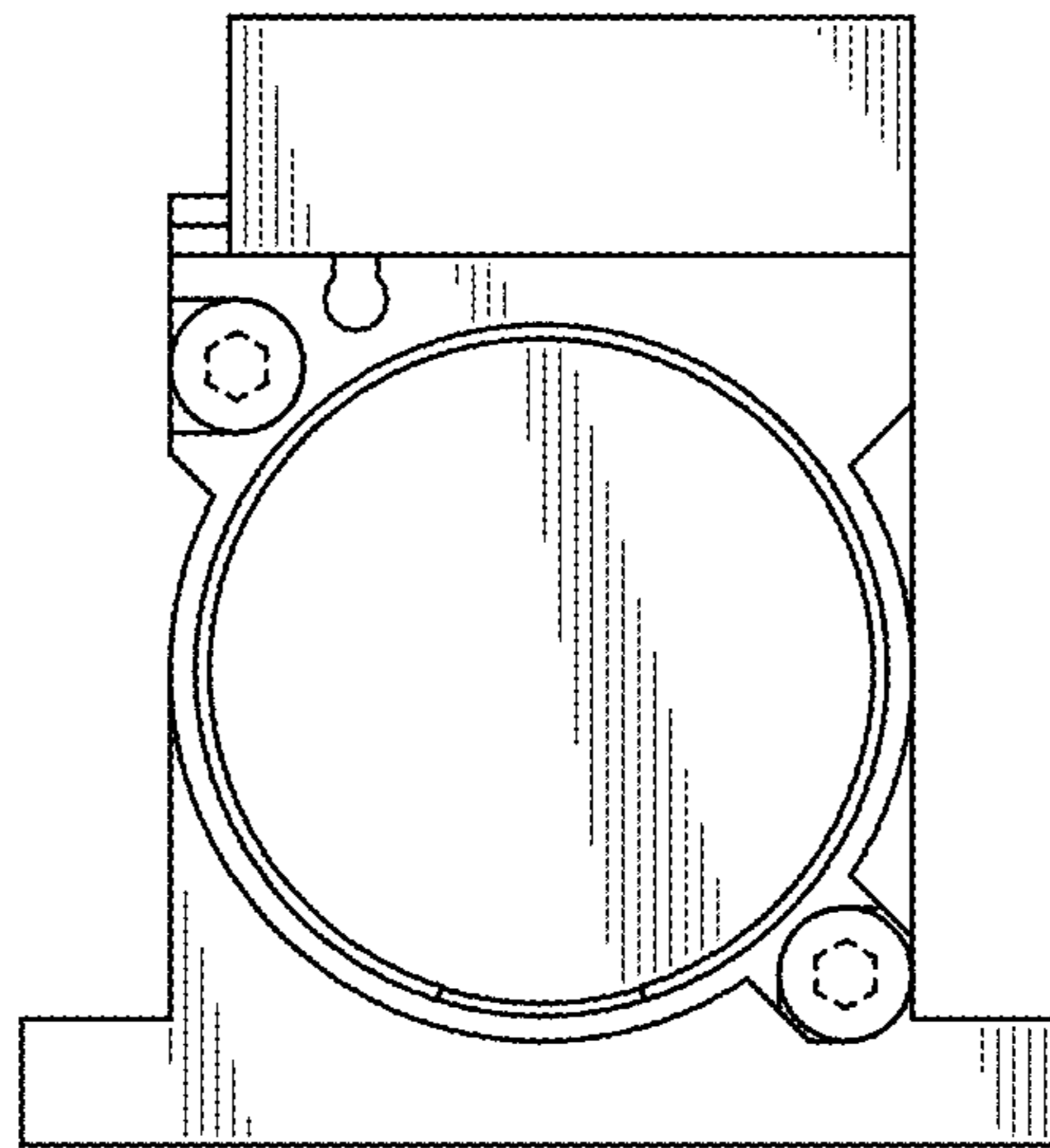

FIG. 18

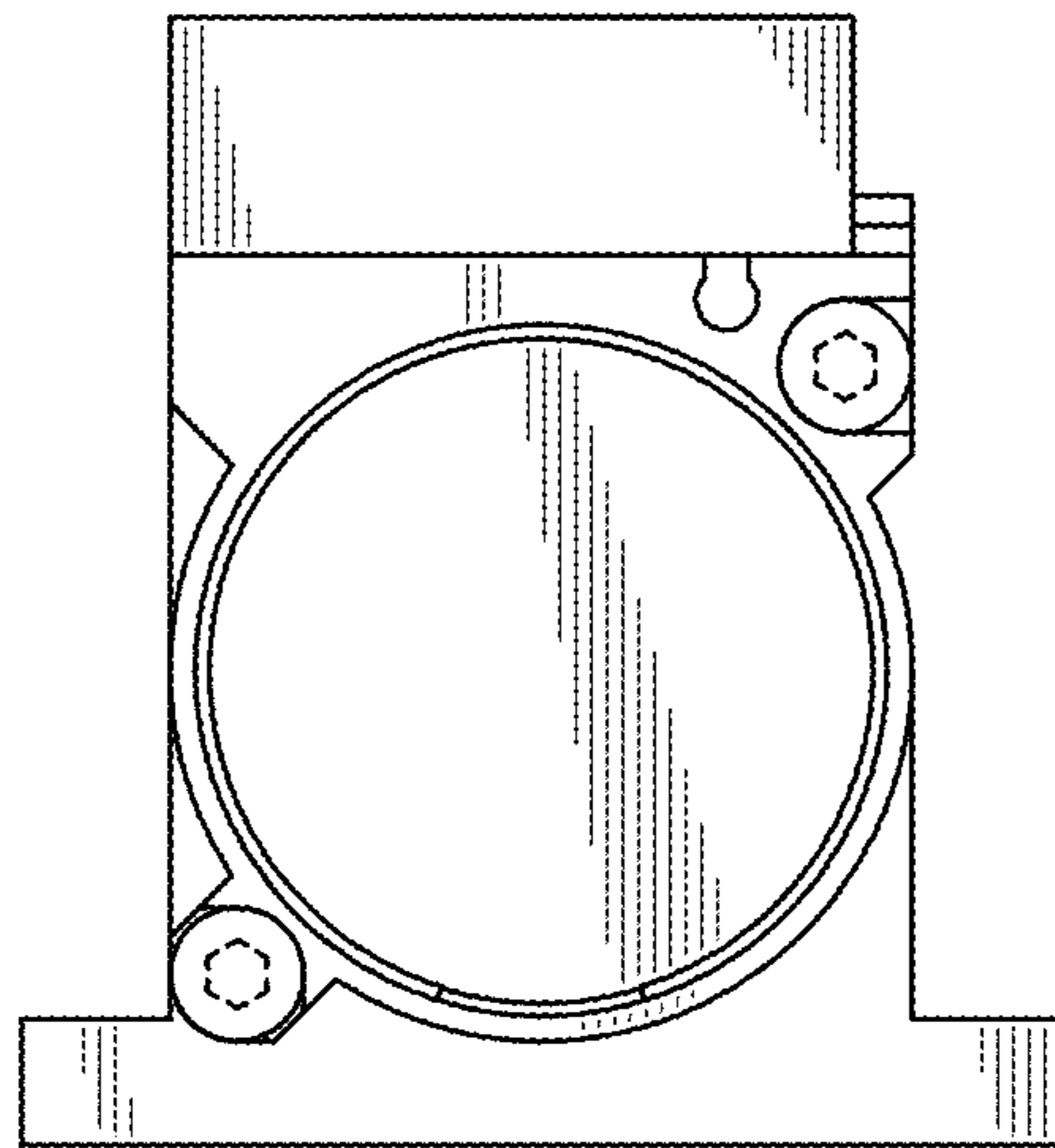

FIG. 19

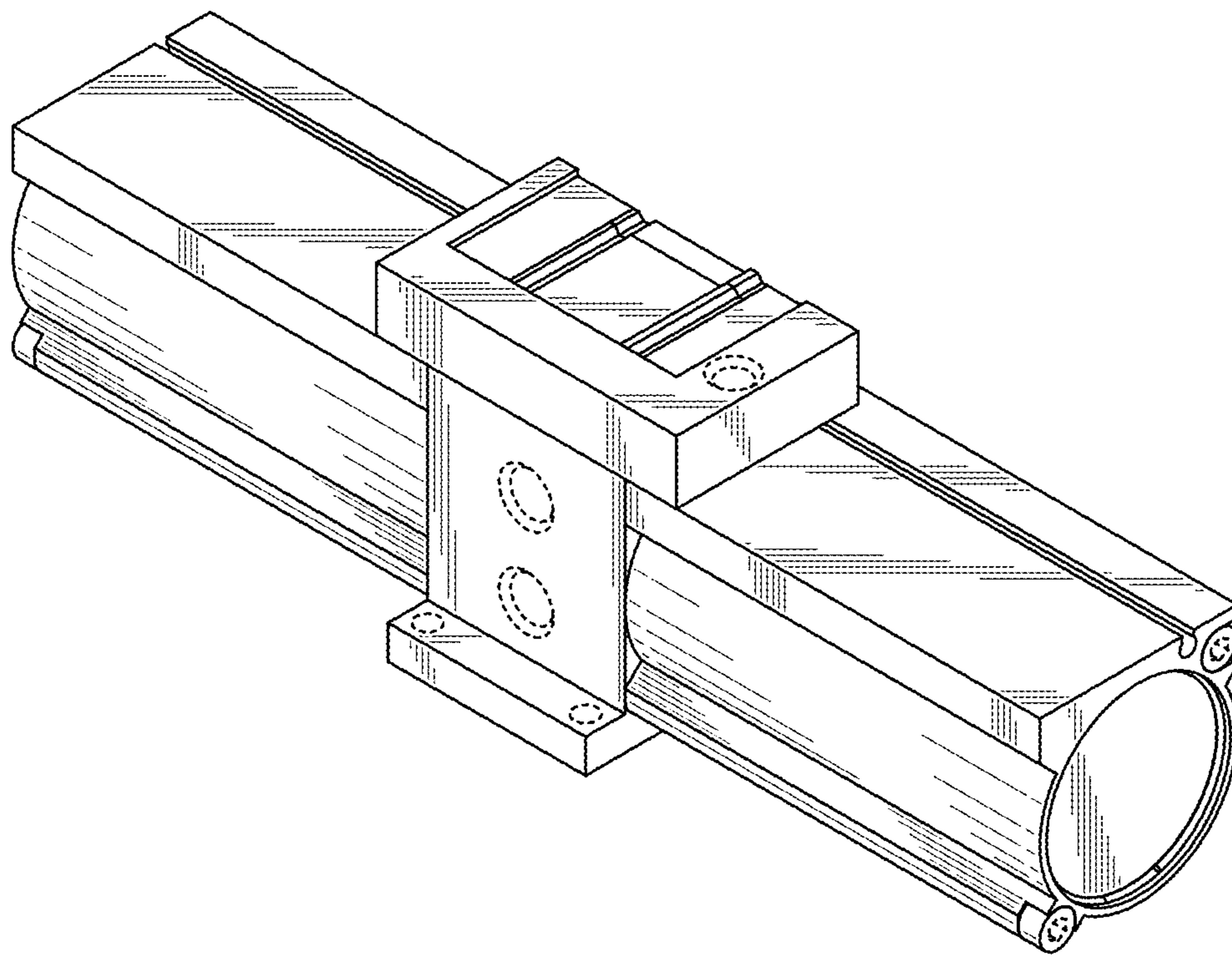

FIG. 20

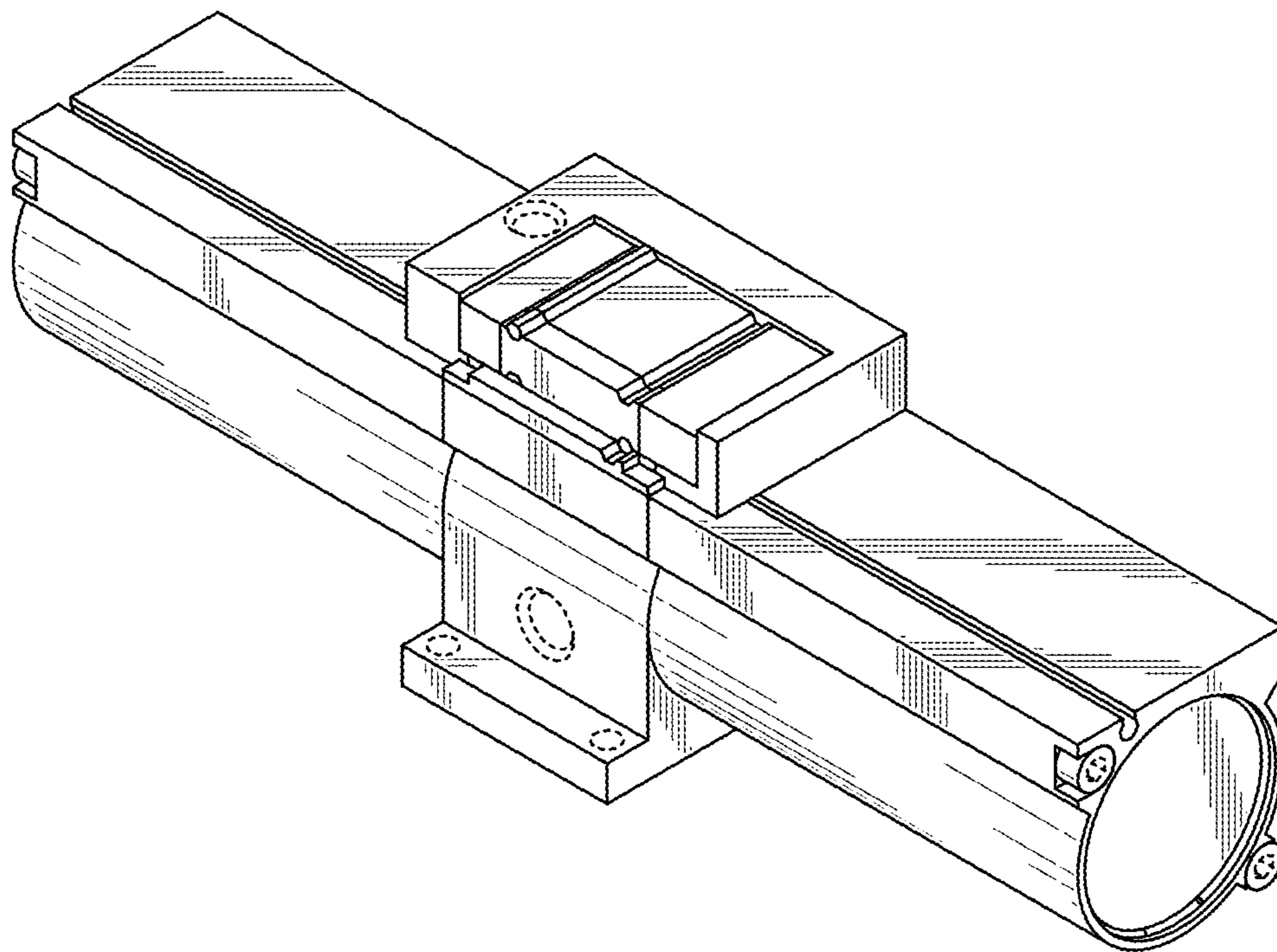

FIG. 21

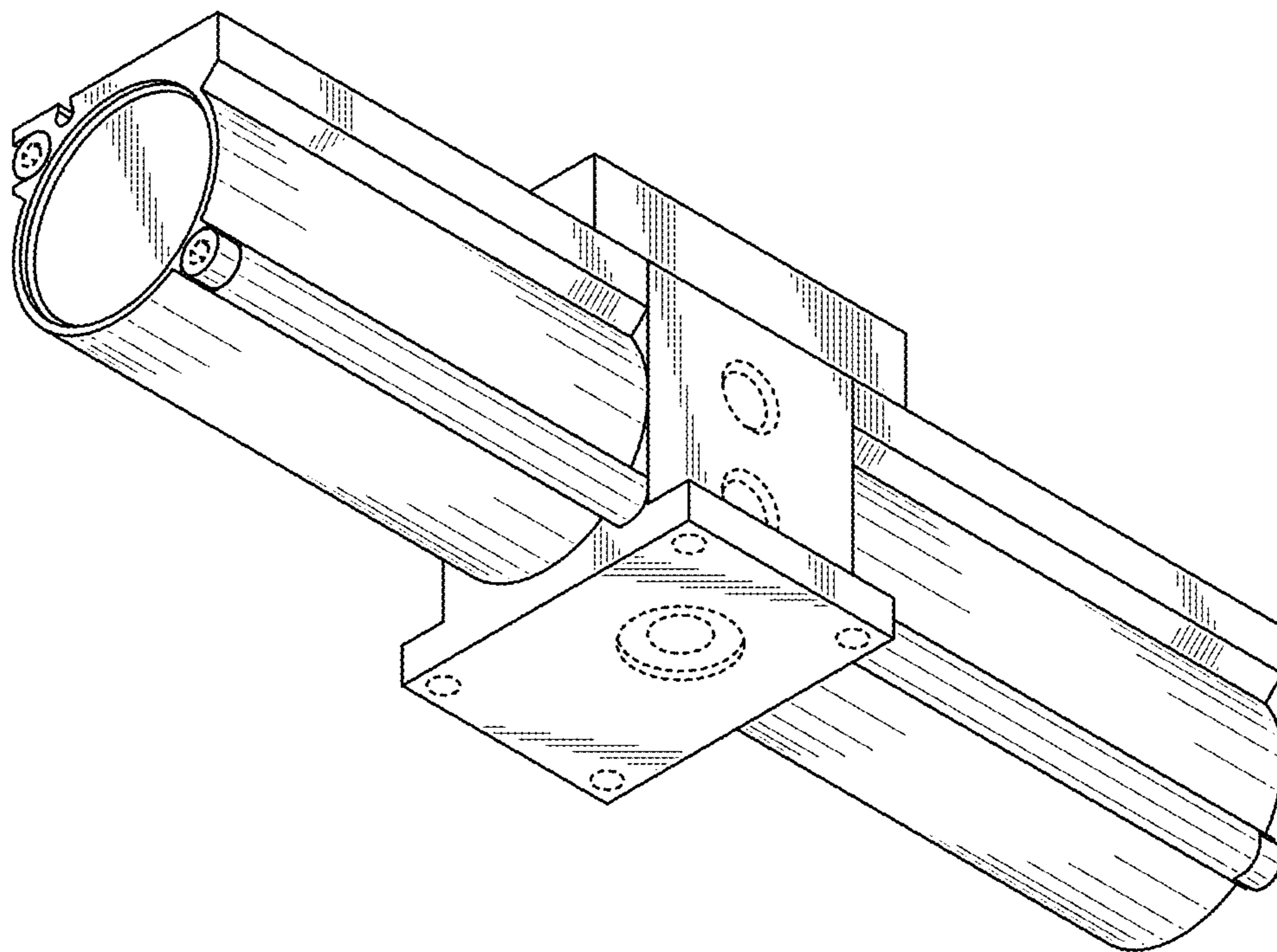

FIG. 22

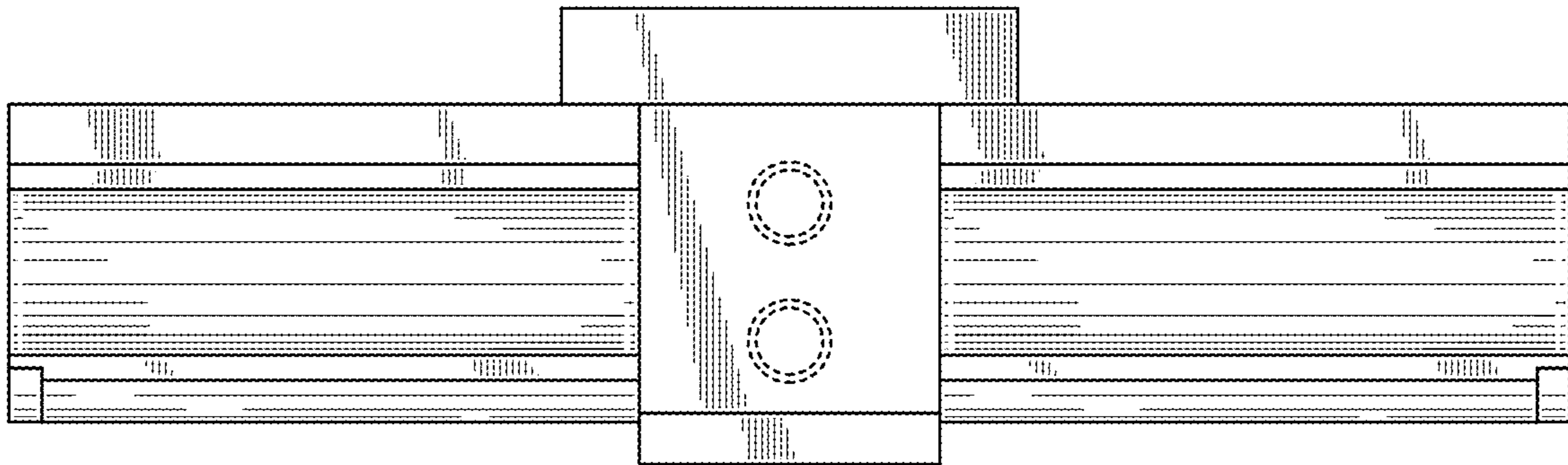

FIG. 23

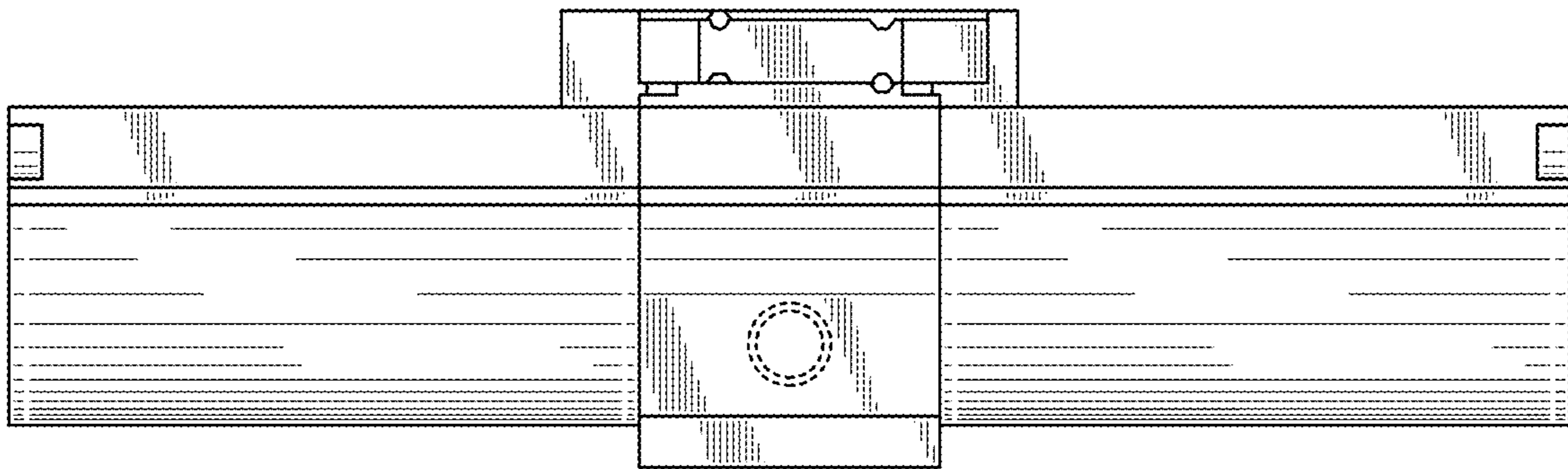

FIG. 24

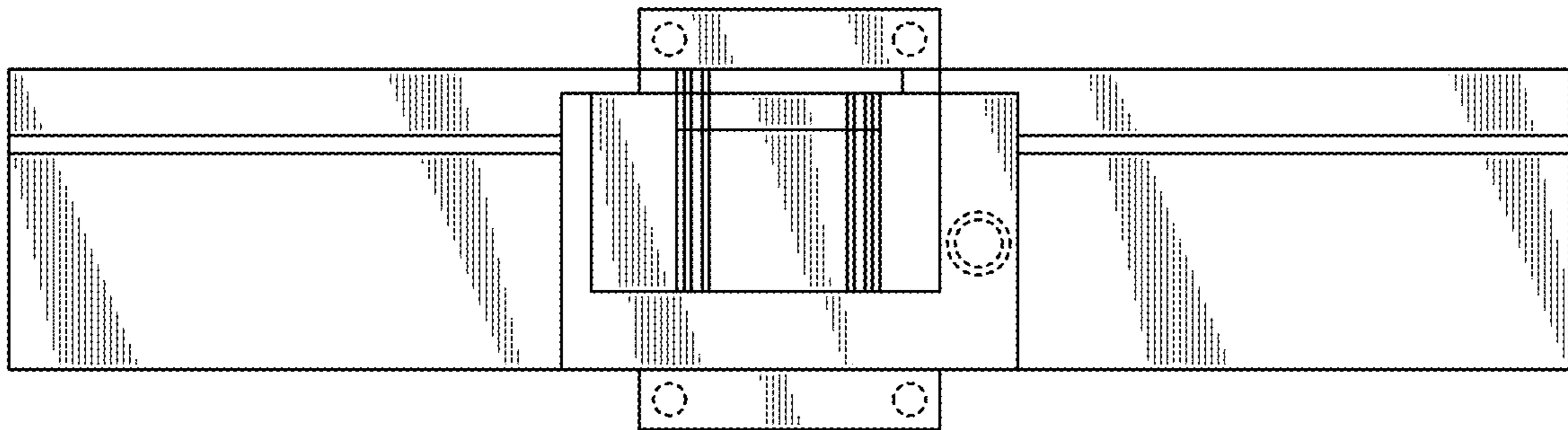

FIG. 25

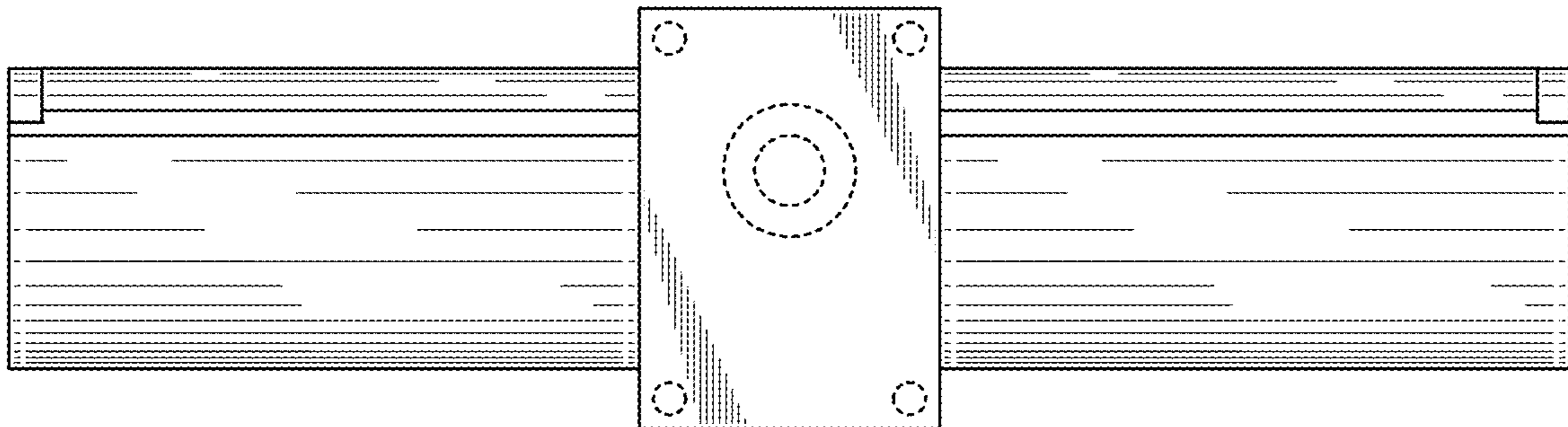

FIG. 26

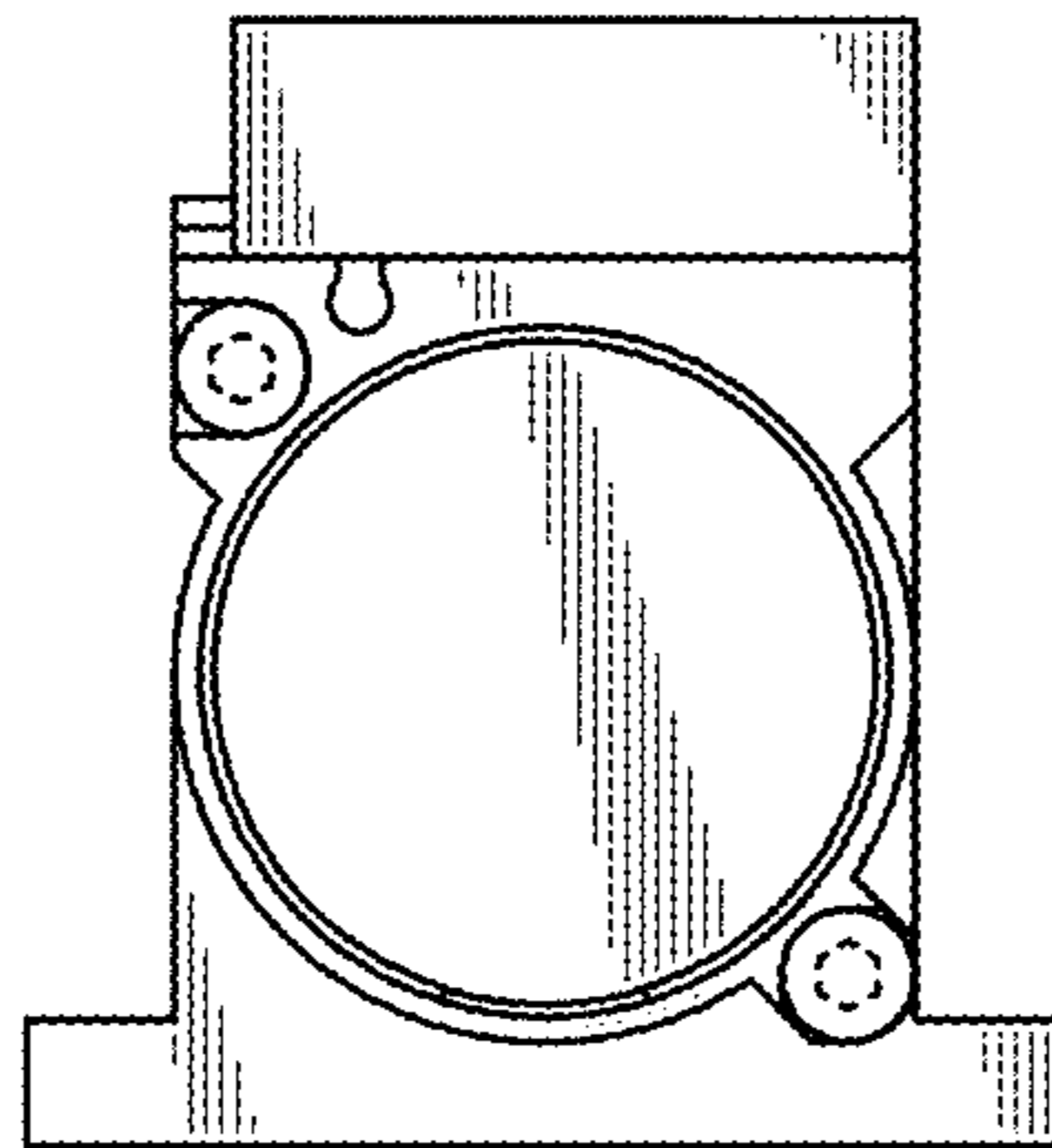

FIG. 27

