



US00D986134S

(12) **United States Design Patent** (10) **Patent No.:** **US D986,134 S**
Byers (45) **Date of Patent:** **** May 16, 2023**

(54) **BOAT BUMPER HOLDER**

(71) Applicant: **Rodney Lee Byers**, Lodi, WI (US)

(72) Inventor: **Rodney Lee Byers**, Lodi, WI (US)

(**) Term: **15 Years**

(21) Appl. No.: **29/803,237**

(22) Filed: **Aug. 11, 2021**

(51) **LOC (14) Cl.** **22-05**

(52) **U.S. Cl.**

USPC **D12/317**

(58) **Field of Classification Search**

USPC D22/138–139, 147–148; D23/261;
D12/317; D26/37–41

CPC B63B 13/00; B63B 13/02; B63B 19/26;
F01P 11/0276; F01P 2050/02; A01K
97/10

See application file for complete search history.

(56) **References Cited**

U.S. PATENT DOCUMENTS

- 3,079,884 A * 3/1963 Miller B63B 59/02
114/219
- 4,526,124 A * 7/1985 Hartwall B63B 59/02
114/364
- 4,773,348 A * 9/1988 Rowley E02B 3/26
211/195
- 5,074,506 A * 12/1991 Larsen B63B 17/00
D34/6
- D332,911 S * 2/1993 Barbour B63B 17/00
D8/373
- D586,425 S * 2/2009 Alley E02B 3/26
D22/147
- 2022/0340243 A1* 10/2022 Byers B63B 59/02

OTHER PUBLICATIONS

PensacolaFishing forum, FS Boat Fender Holder, published Sep. 28, 2007 [retrieved Nov. 23, 2022]. Retrieved from the internet<<https://www.pensacolafishingforum.com/threads/fs-boat-fender-holders.913888/>> (Year: 2007).*

* cited by examiner

Primary Examiner — Joseph Kukella

Assistant Examiner — Lavon M. Amerson

(74) *Attorney, Agent, or Firm* — Boardman & Clark LLP

(57) **CLAIM**

The ornamental design for a boat bumper holder, as shown and described.

DESCRIPTION

FIG. 1 is a perspective view of a boat bumper holder, showing my new design;

FIG. 2 is a front elevation view of the boat bumper holder in FIG. 1;

FIG. 3 is a rear elevation view of the boat bumper holder of FIG. 1;

FIG. 4 is a left-side elevation view of the boat bumper holder of FIG. 1;

FIG. 5 is a right-side elevation view of the boat bumper holder of FIG. 1;

FIG. 6 is a top view of the boat bumper holder of FIG. 1;

FIG. 7 is a bottom plan view of the boat bumper holder of FIG. 1;

FIG. 8 is a second perspective view of a boat bumper holder, showing my new design;

FIG. 9 is a front elevation view of the boat bumper holder in FIG. 8;

FIG. 10 is a rear elevation view of the boat bumper holder of FIG. 8;

FIG. 11 is a left-side elevation view of the boat bumper holder of FIG. 8; and,

FIG. 12 is a right-side elevation view of the boat bumper holder of FIG. 8.

The broken dash lines shown in the drawings represent form no part of the claimed design. The article is shown with symbolic breaks in its length using break lines, and the appearance of any portion of the article between the break lines forms no part of the claimed design.

1 Claim, 14 Drawing Sheets

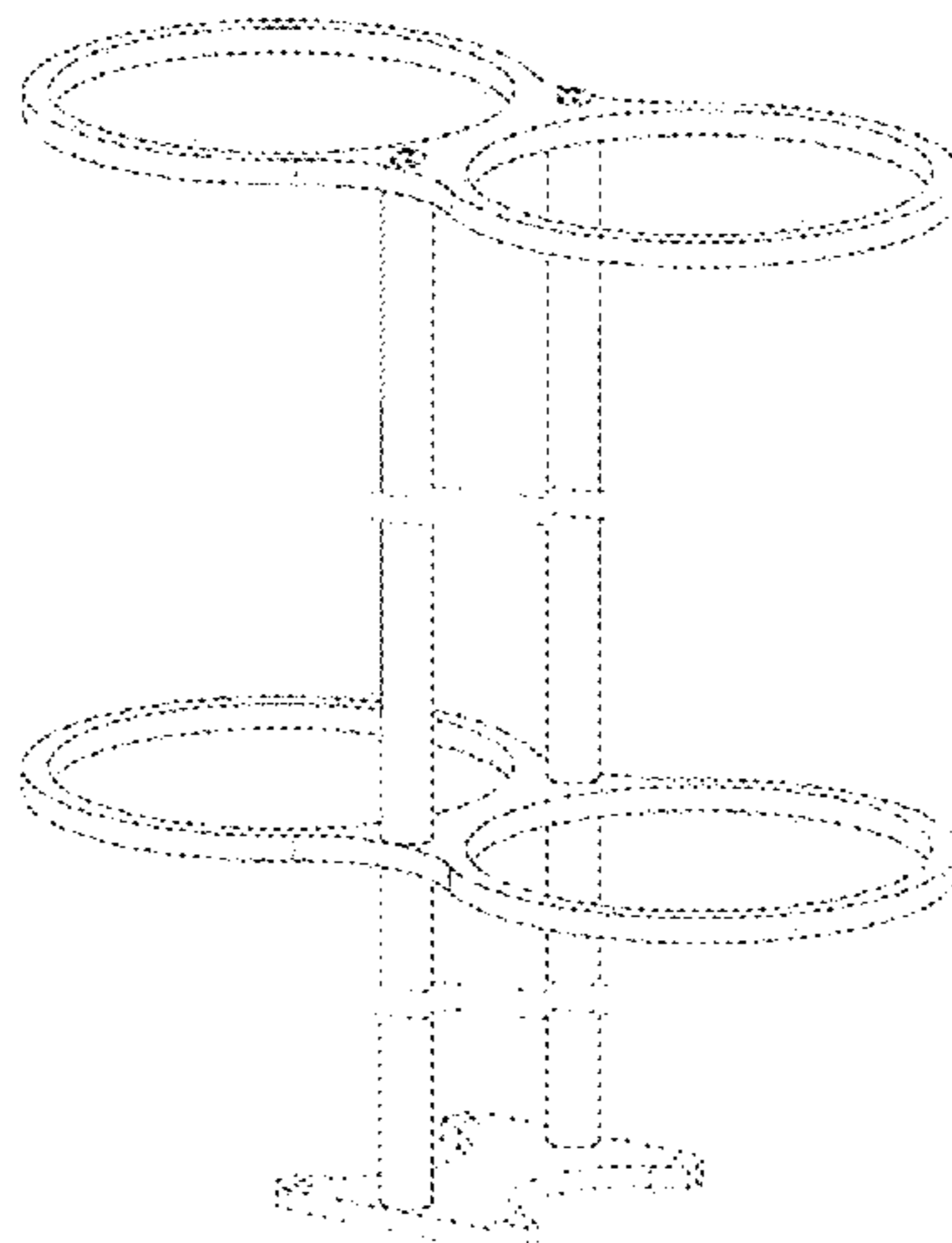

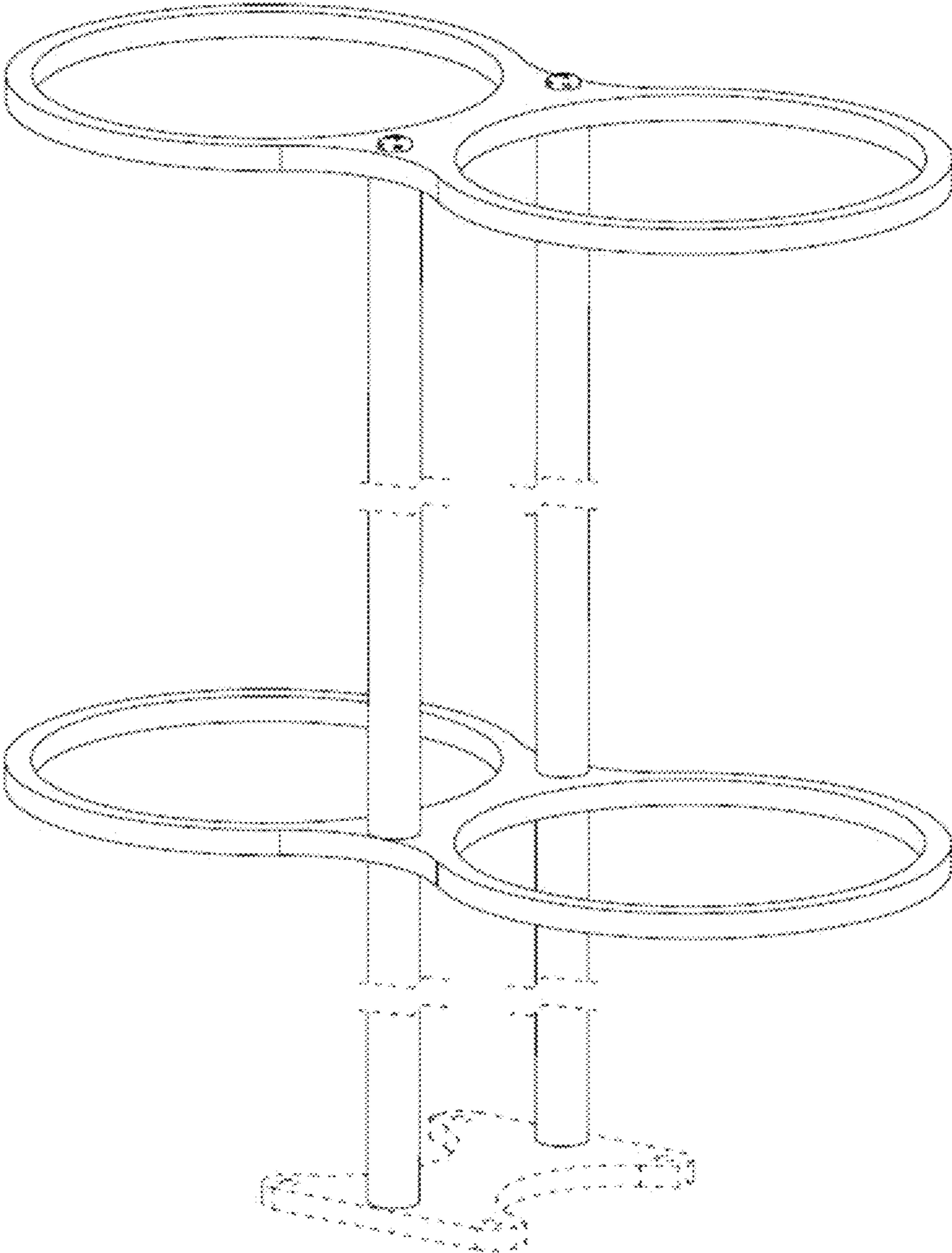

FIG. 1

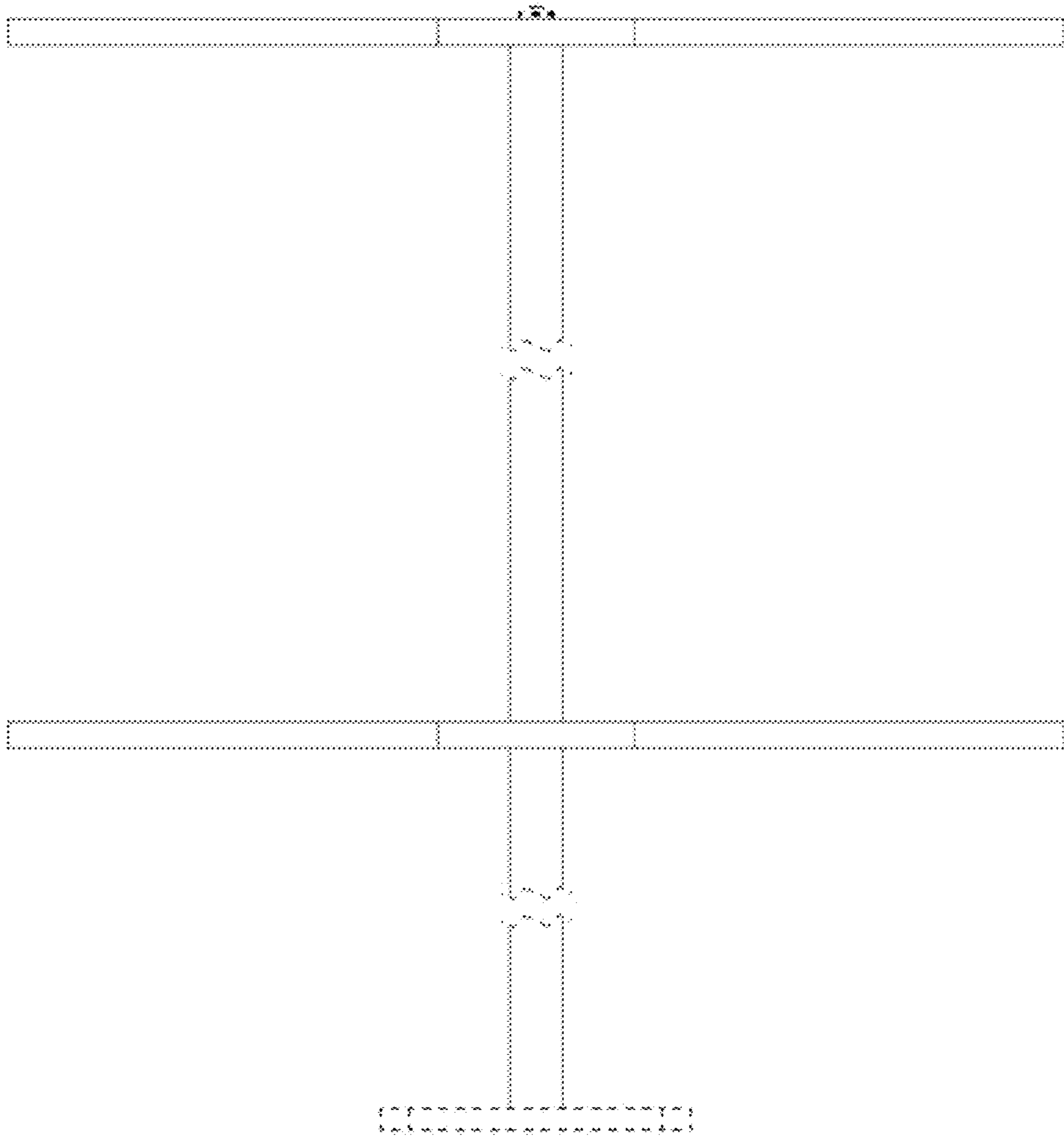

FIG. 2

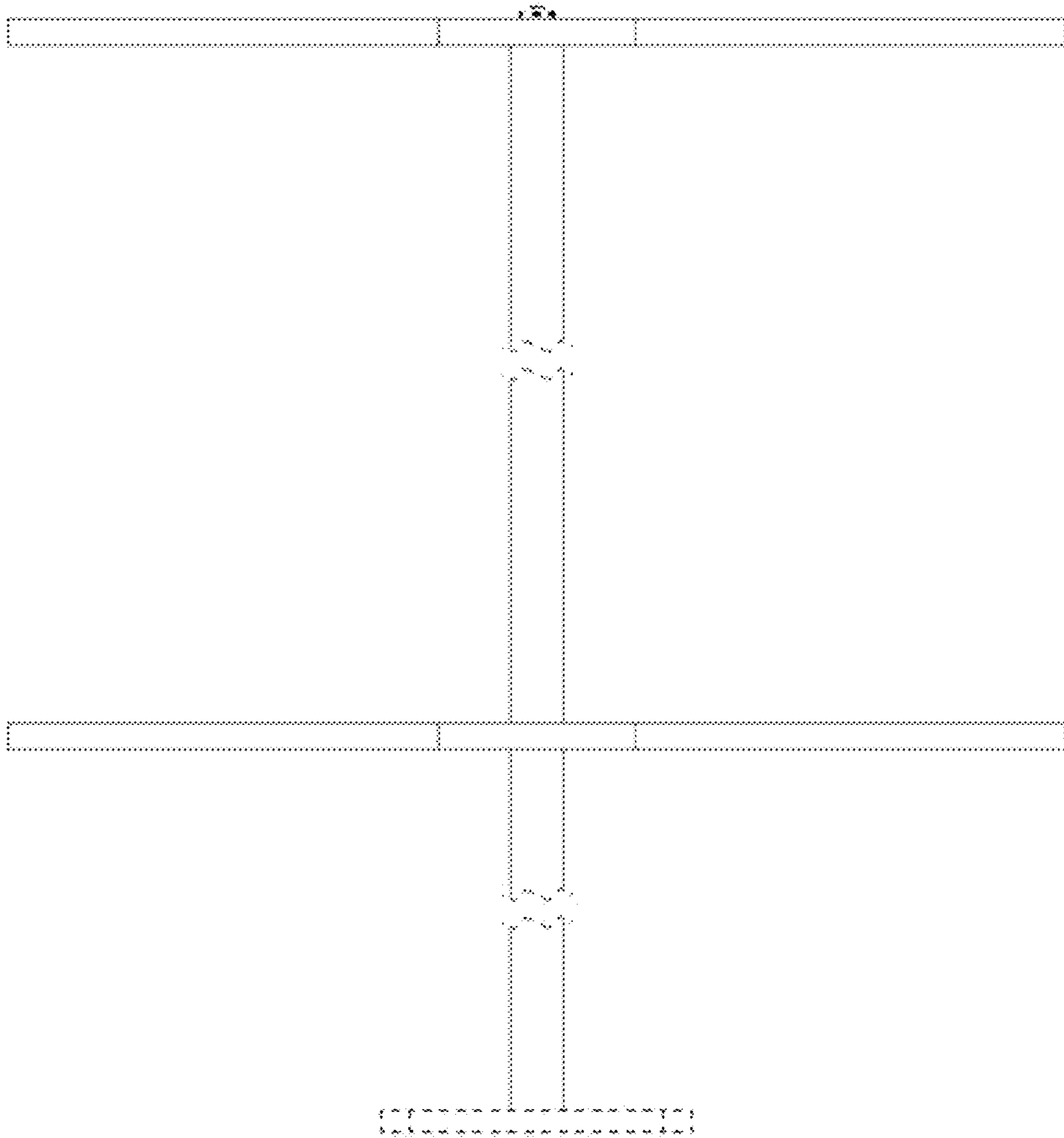

FIG. 3

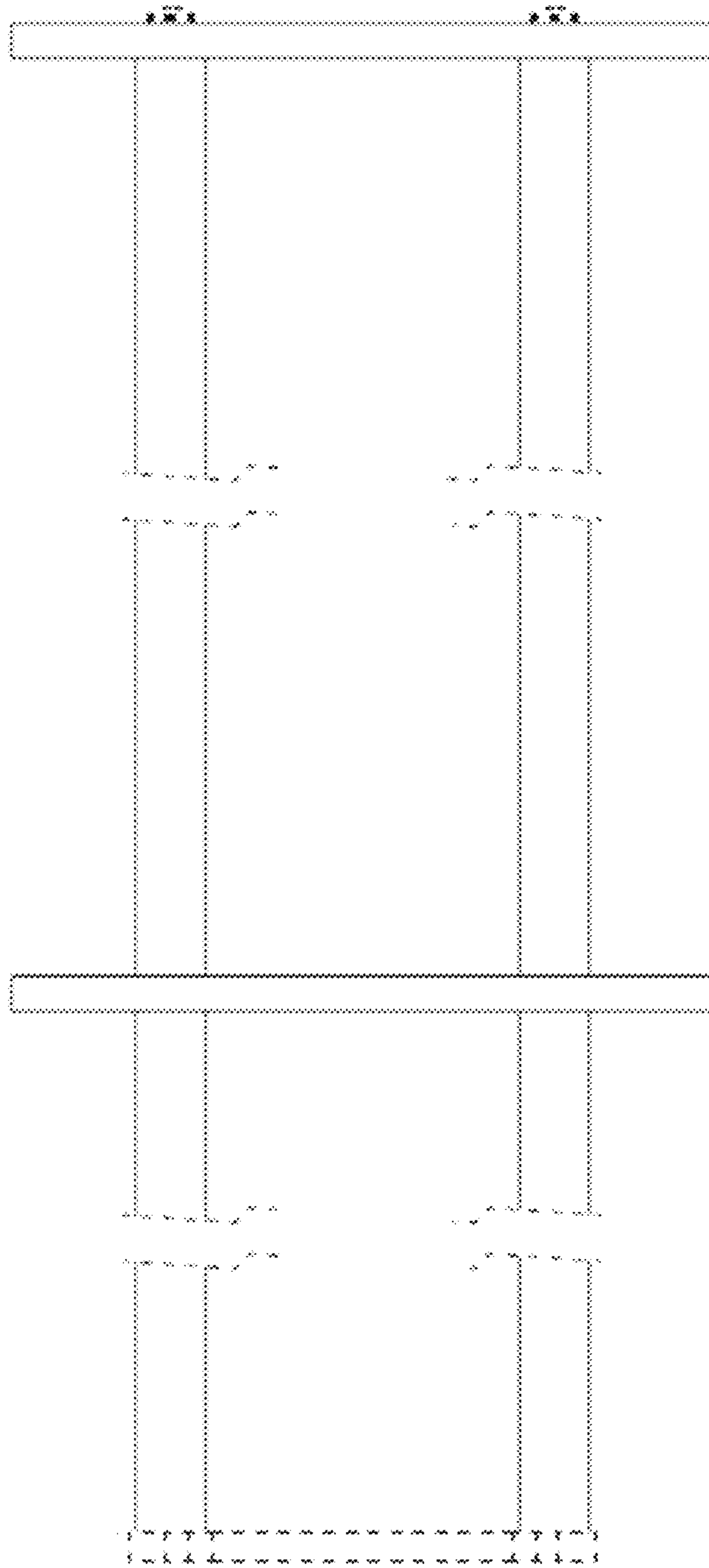

FIG. 4

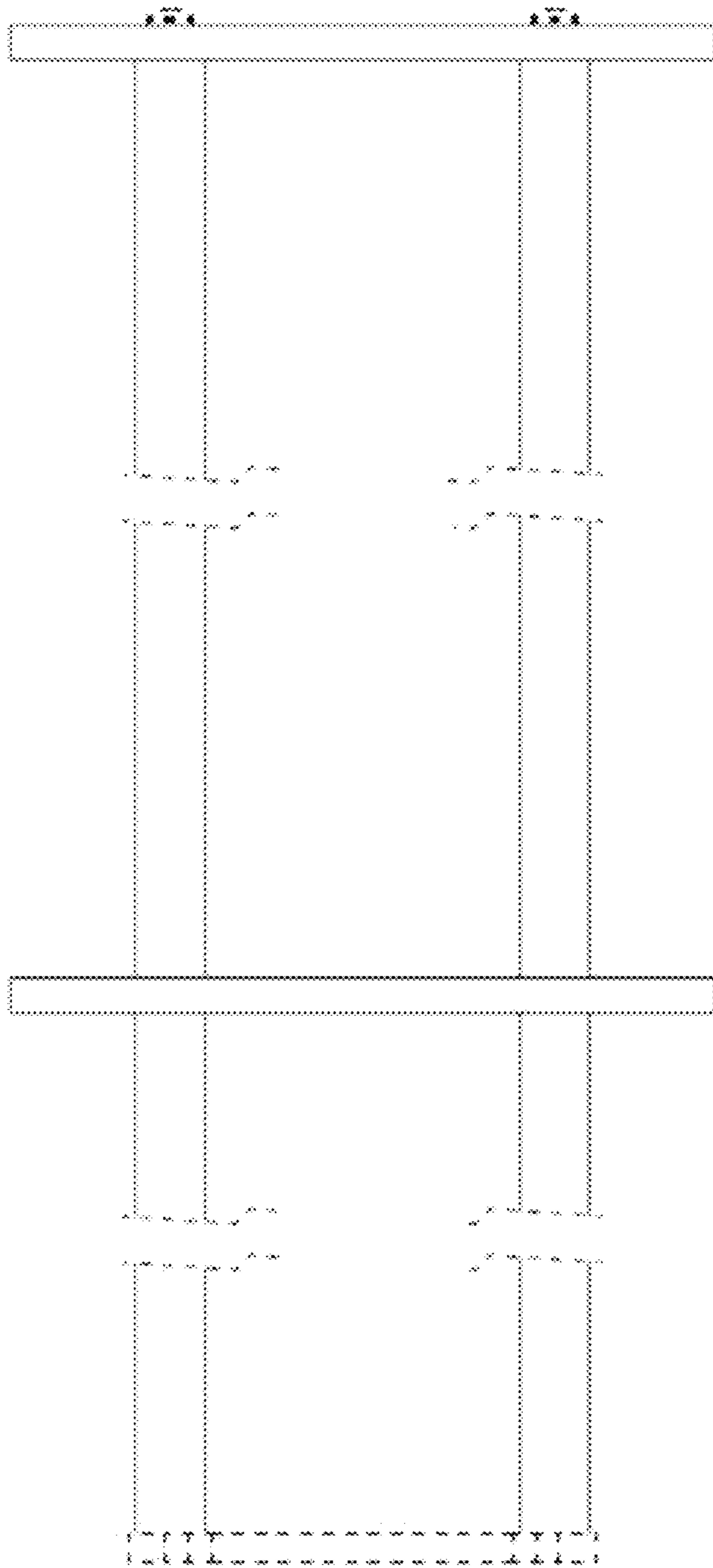

FIG. 5

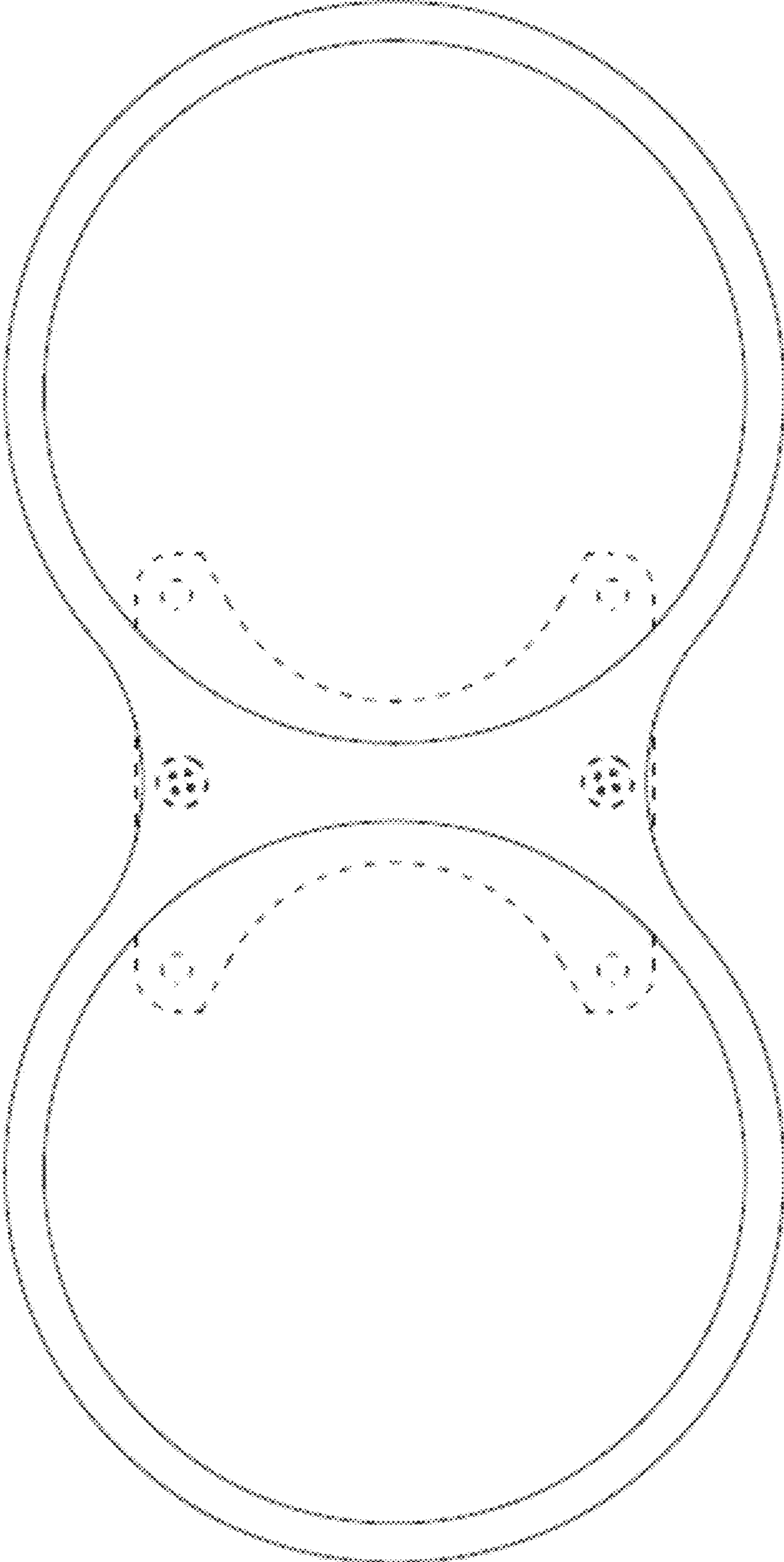

FIG. 6

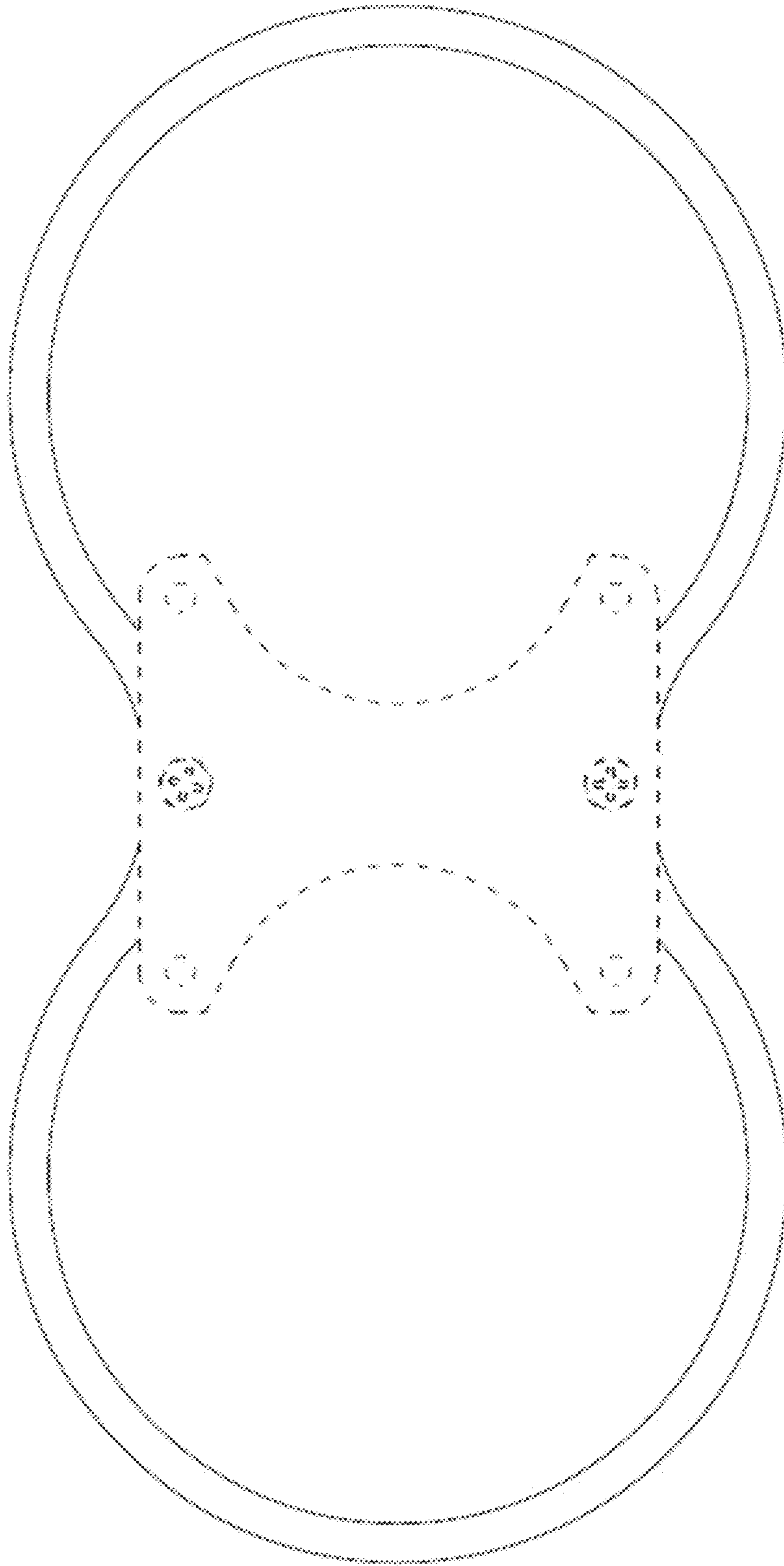

FIG. 7

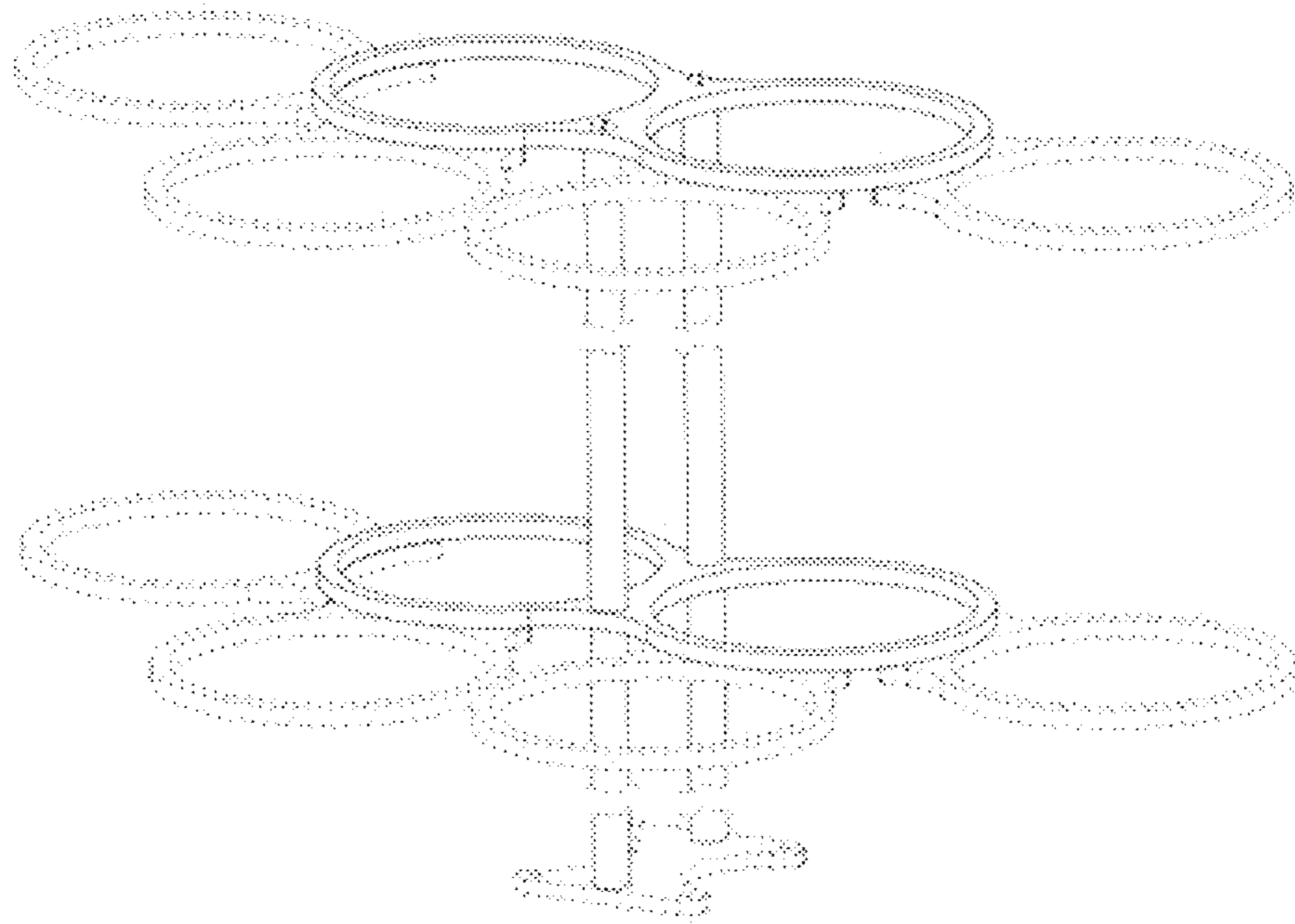

FIG. 8

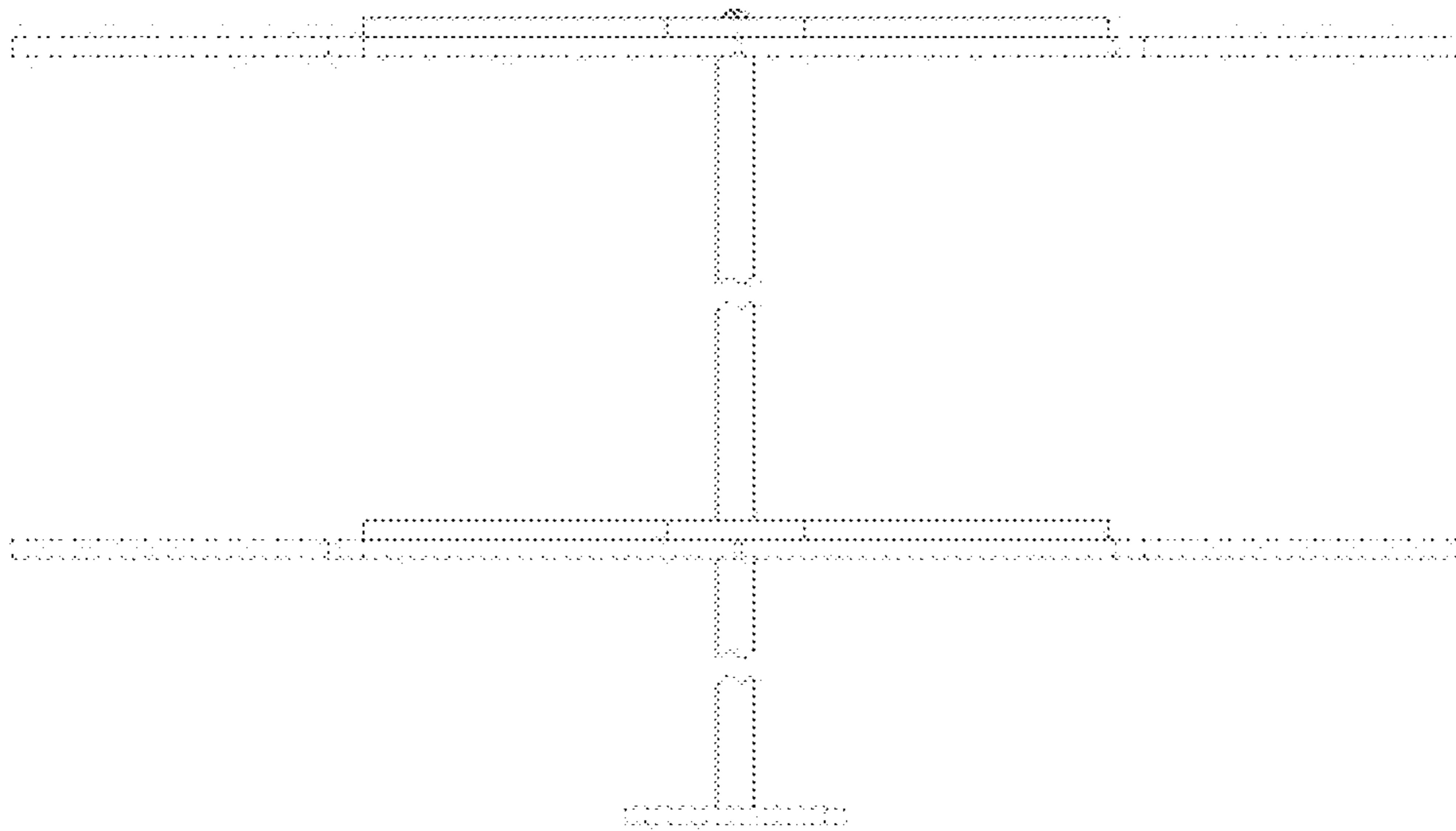

FIG. 9

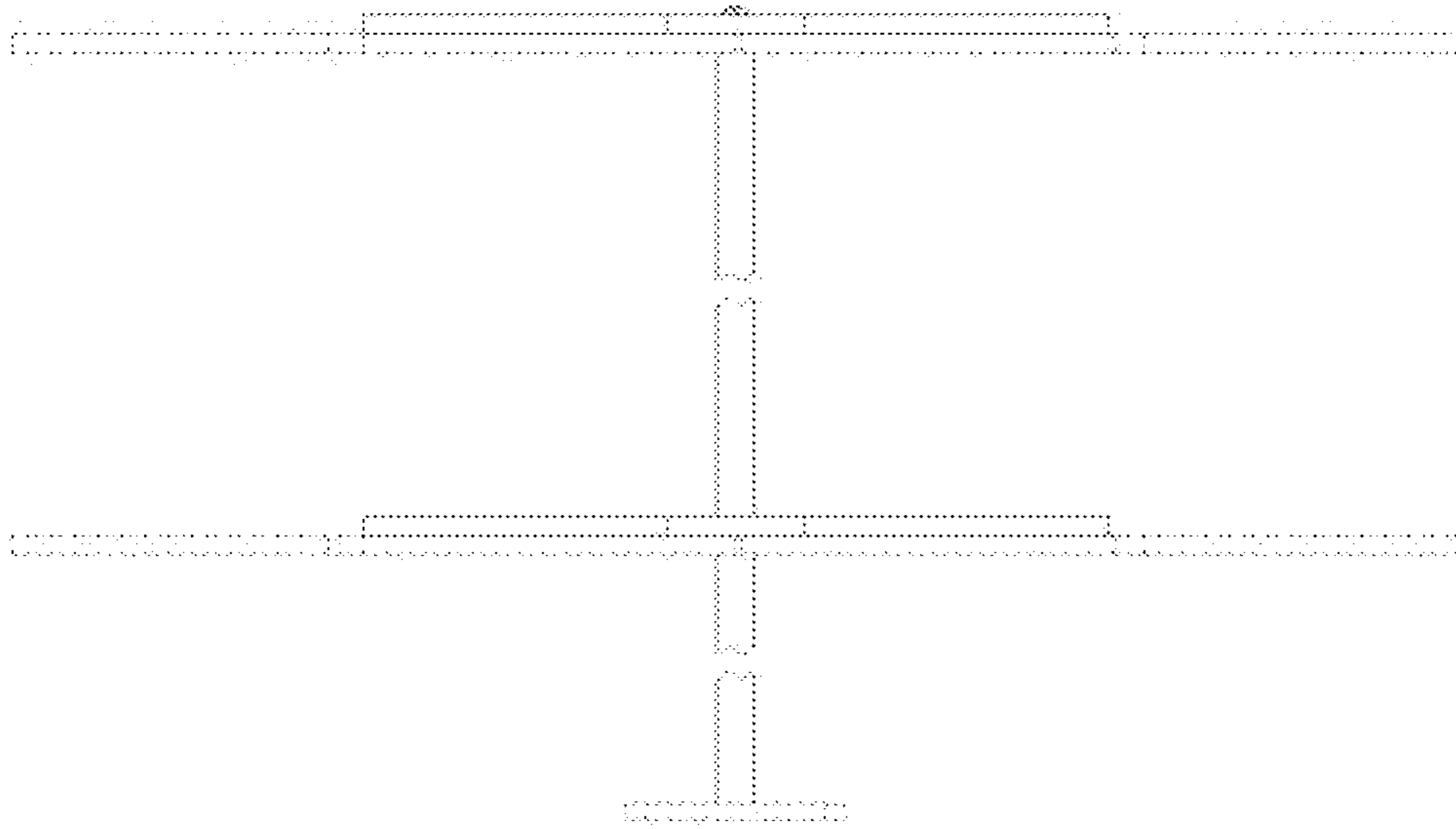

FIG. 10

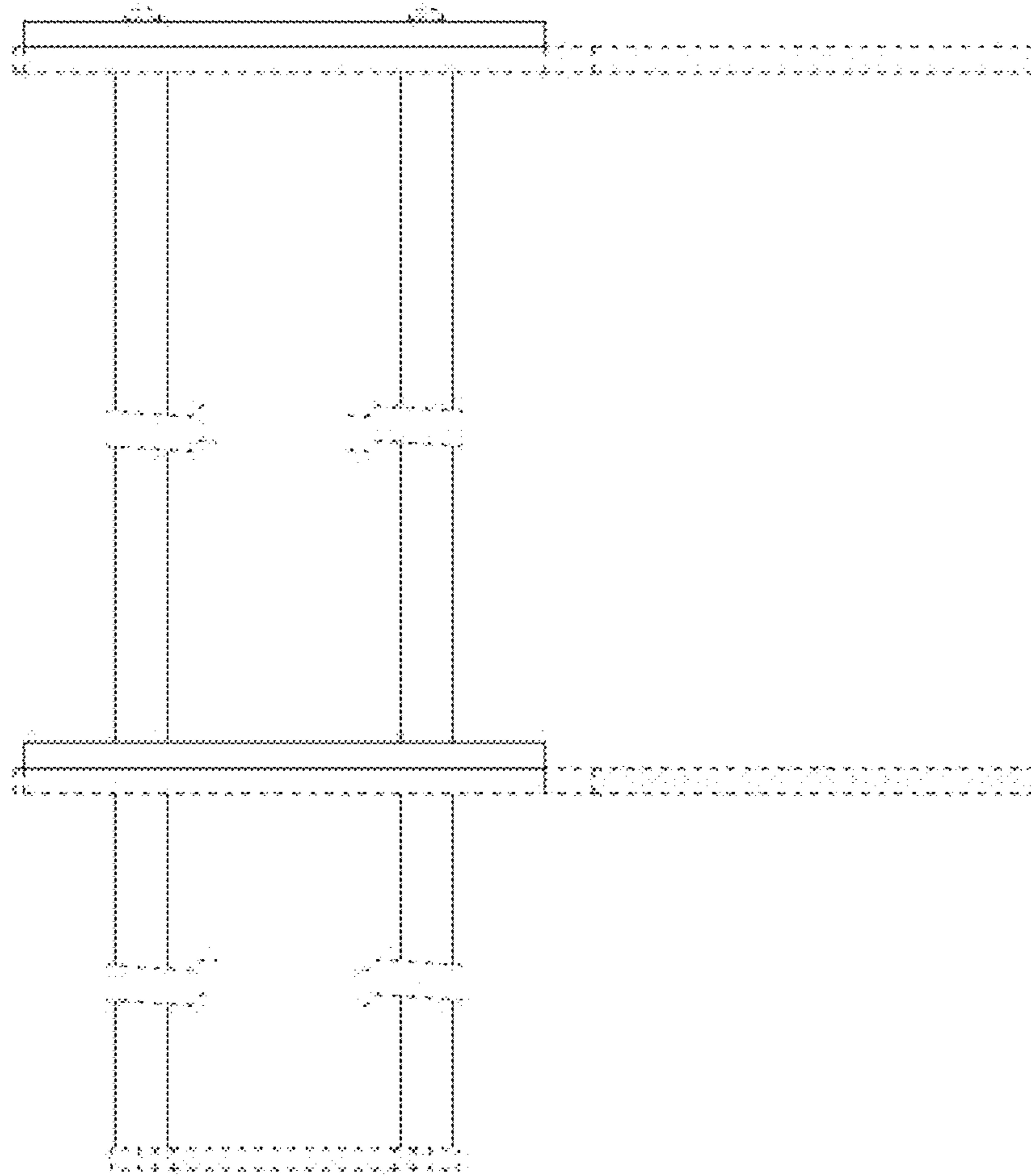

FIG. 11

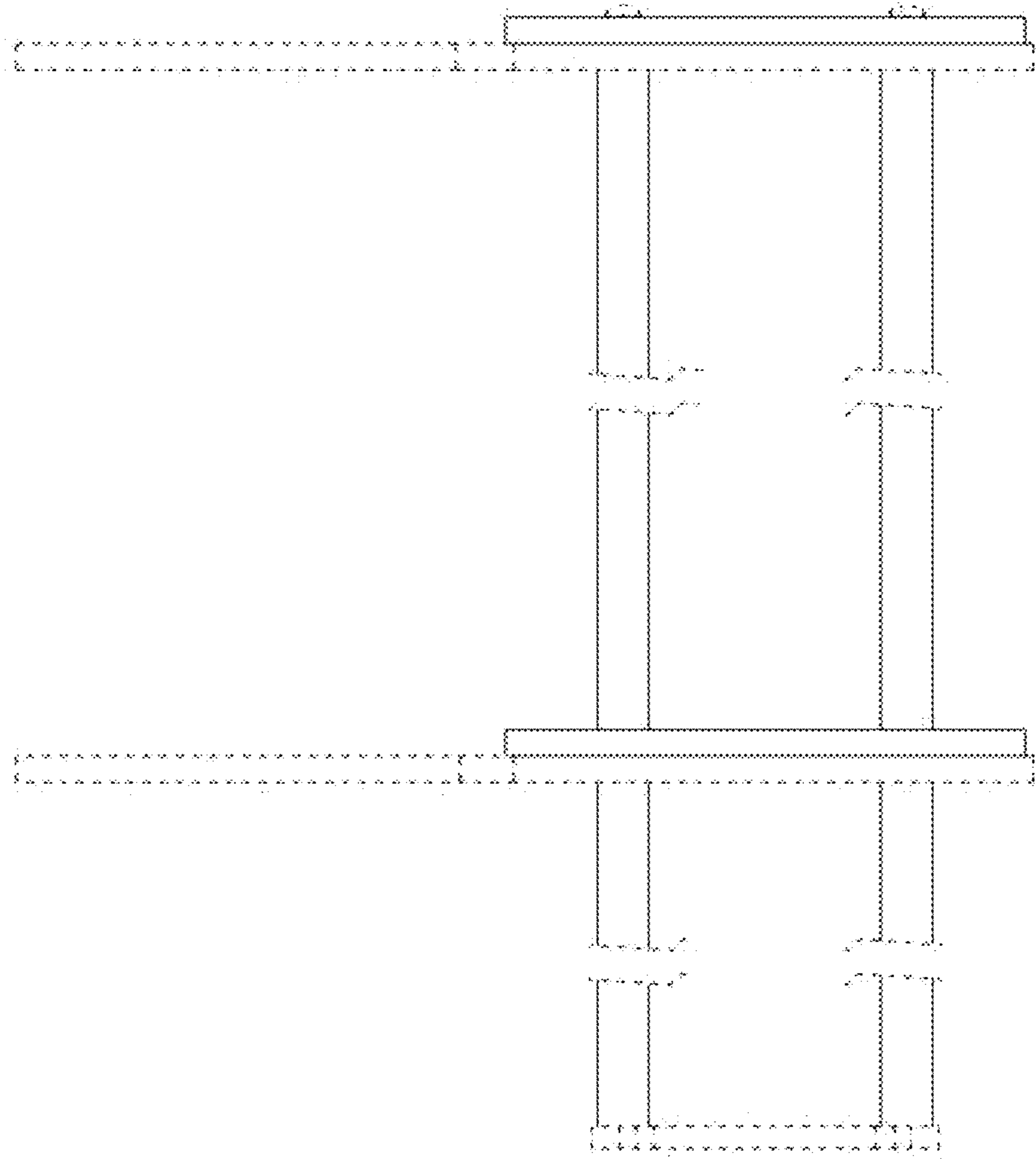

FIG. 12

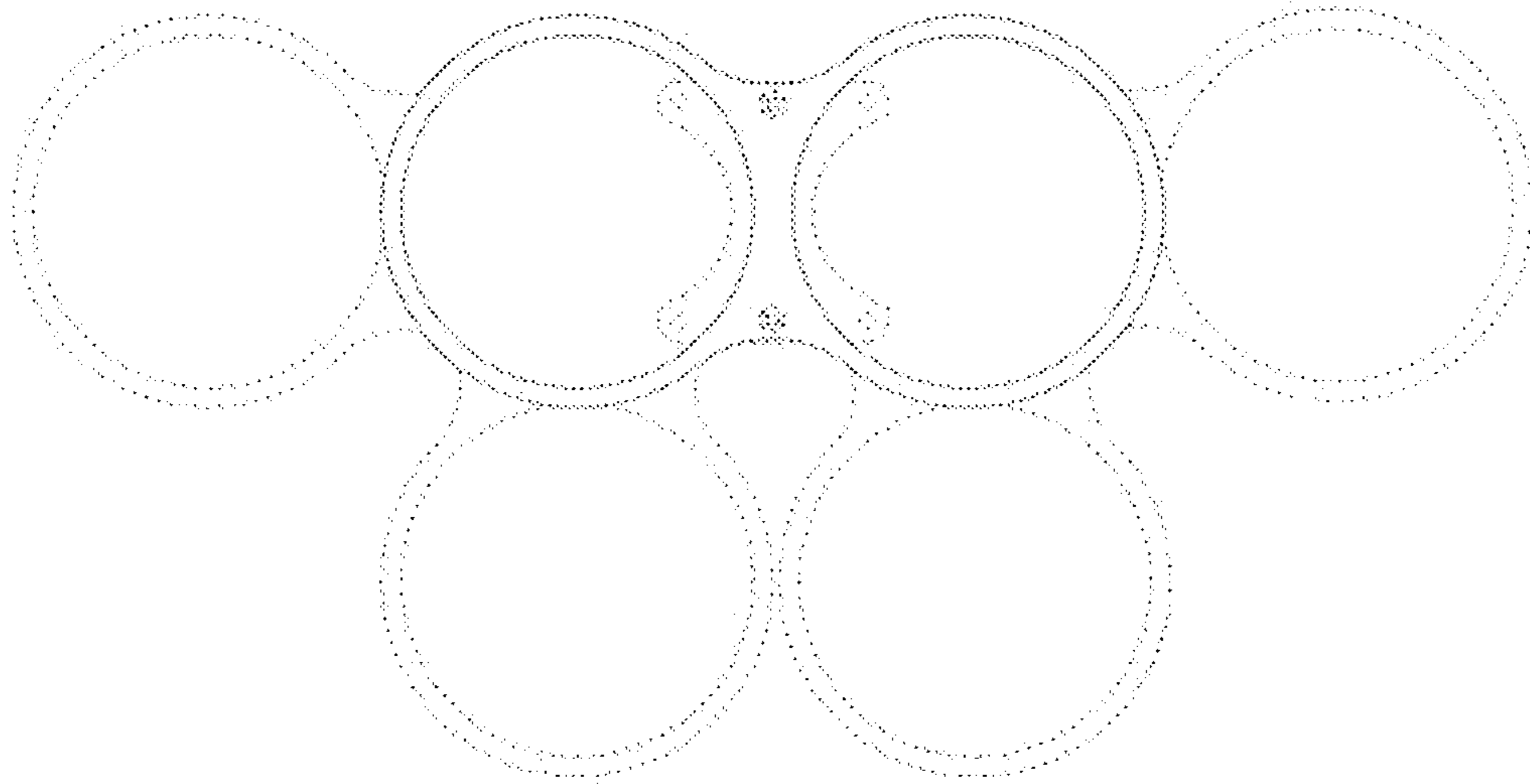

FIG. 13

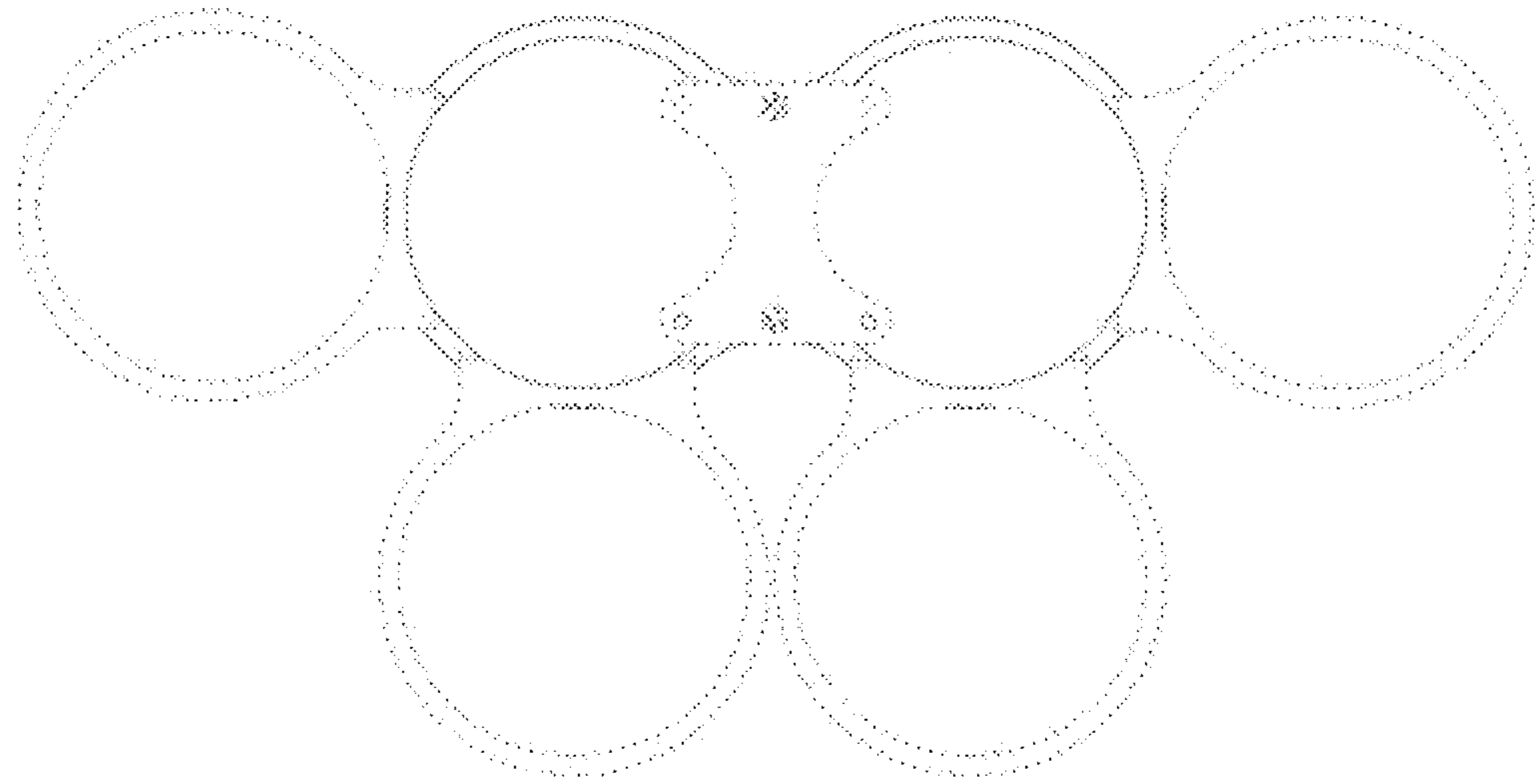

FIG. 14