



US00D985625S

(12) **United States Design Patent**  
**Sullivan**

(10) **Patent No.:** **US D985,625 S**

(45) **Date of Patent:** **\*\* May 9, 2023**

(54) **BRIDGED MINI-BULKHEADS**

(71) Applicant: **XConnect, LLC**, Denver, CO (US)

(72) Inventor: **Shelby L. Sullivan**, Minot, ND (US)

(73) Assignee: **XConnect, LLC**, Denver, CO (US)

(\*\*) Term: **15 Years**

(21) Appl. No.: **29/846,650**

(22) Filed: **Jul. 18, 2022**

**Related U.S. Application Data**

(60) Division of application No. 29/803,664, filed on Aug. 14, 2021, now Pat. No. Des. 979,611, which is a continuation-in-part of application No. 29/744,986, filed on Aug. 3, 2020, now Pat. No. Des. 947,253.

(51) **LOC (14) Cl.** ..... **15-03**

(52) **U.S. Cl.**

USPC ..... **D15/21**

(58) **Field of Classification Search**

USPC ..... D15/21

CPC ..... E21B 43/11; E21B 43/112; E21B 43/114;

E21B 43/116; E21B 43/117; E21B

43/119; E21B 43/00; F42D 1/04; F42D

1/05; F42D 1/043

See application file for complete search history.

(56) **References Cited**

**U.S. PATENT DOCUMENTS**

10,731,444 B2 \* 8/2020 Wells ..... E21B 47/092

10,858,919 B2 \* 12/2020 Anthony ..... E21B 43/1185

10,914,145 B2 \* 2/2021 Sullivan ..... E21B 43/1185

11,078,763 B2 \* 8/2021 Anthony ..... E21B 43/119

11,091,987 B1 \* 8/2021 Benker ..... E21B 43/119

2012/0199352 A1 \* 8/2012 Lanclos ..... F42D 1/05

166/297

2020/0217635 A1 \* 7/2020 Eitschberger ..... F42D 1/04

2020/0308938 A1 \* 10/2020 Sullivan ..... E21B 43/116

\* cited by examiner

*Primary Examiner* — Mark A Goodwin

(74) *Attorney, Agent, or Firm* — Peter L. Brewer

(57) **CLAIM**

The ornamental design for bridged mini-bulkheads, as shown and described.

**DESCRIPTION**

FIG. 1 is a perspective view of bridged mini-bulkheads, showing my new design. The view is taken from a top, front and right side.

FIG. 2 is a second perspective view of the bridged mini-bulkheads of FIG. 1. Here, the view is taken from a bottom, rear and left side.

FIG. 3 is a top plan view of the bridged mini-bulkheads of FIG. 1. Features that were shown in dashed lines in FIGS. 1 and 2 have been removed for clarity.

FIG. 4 is a bottom plan view thereof.

FIG. 5 is a front plan view thereof.

FIG. 6 is a rear plan view thereof.

FIG. 7 is a right side elevation view thereof; and,

FIG. 8 is a left side elevation view thereof.

The broken lines in the drawings depict portions of the bridged min-bulkheads that form no part of the claimed designs. Particularly, in FIGS. 1 and 2 the electrical wires on the end are included simply to show environment.

**1 Claim, 6 Drawing Sheets**

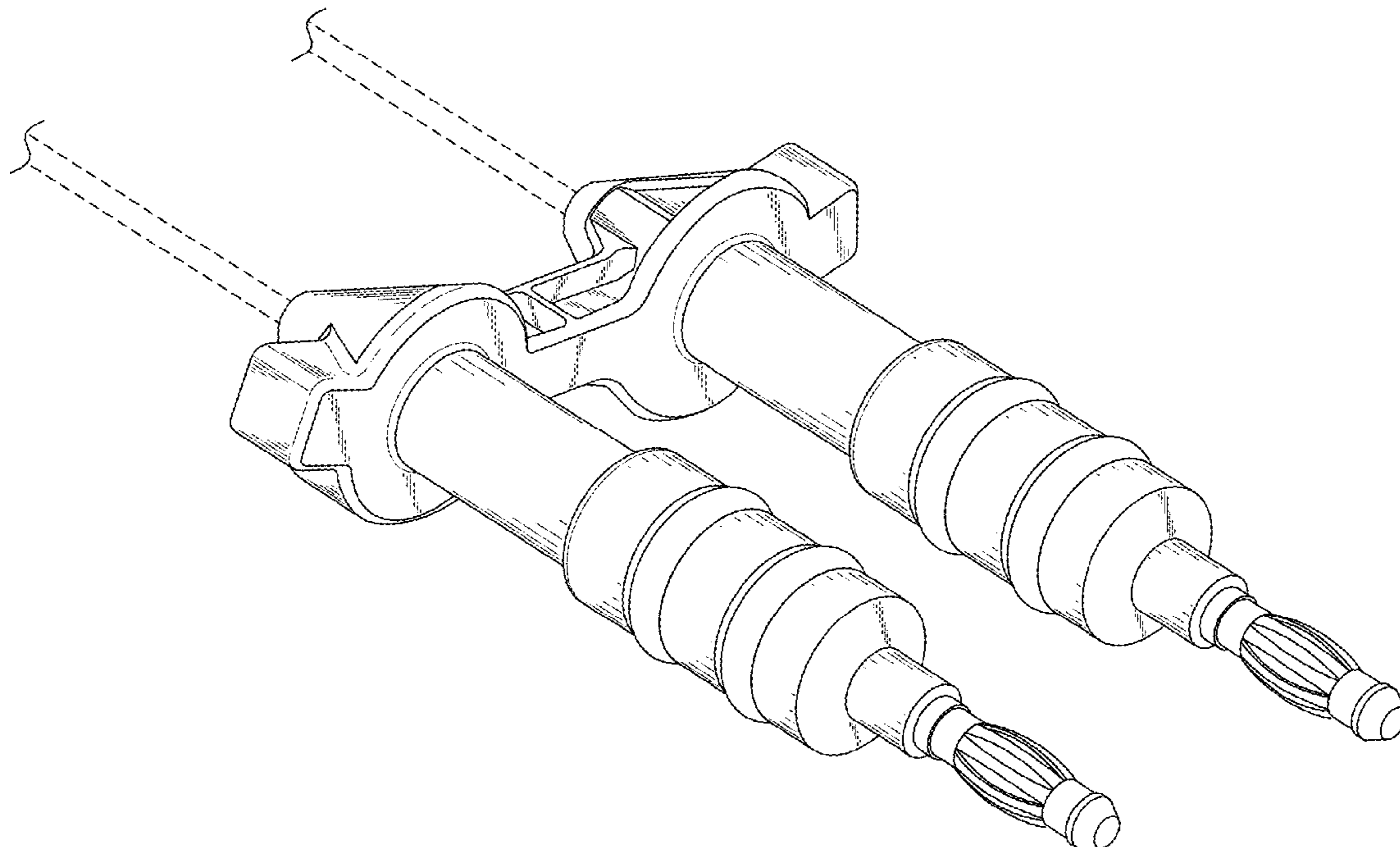

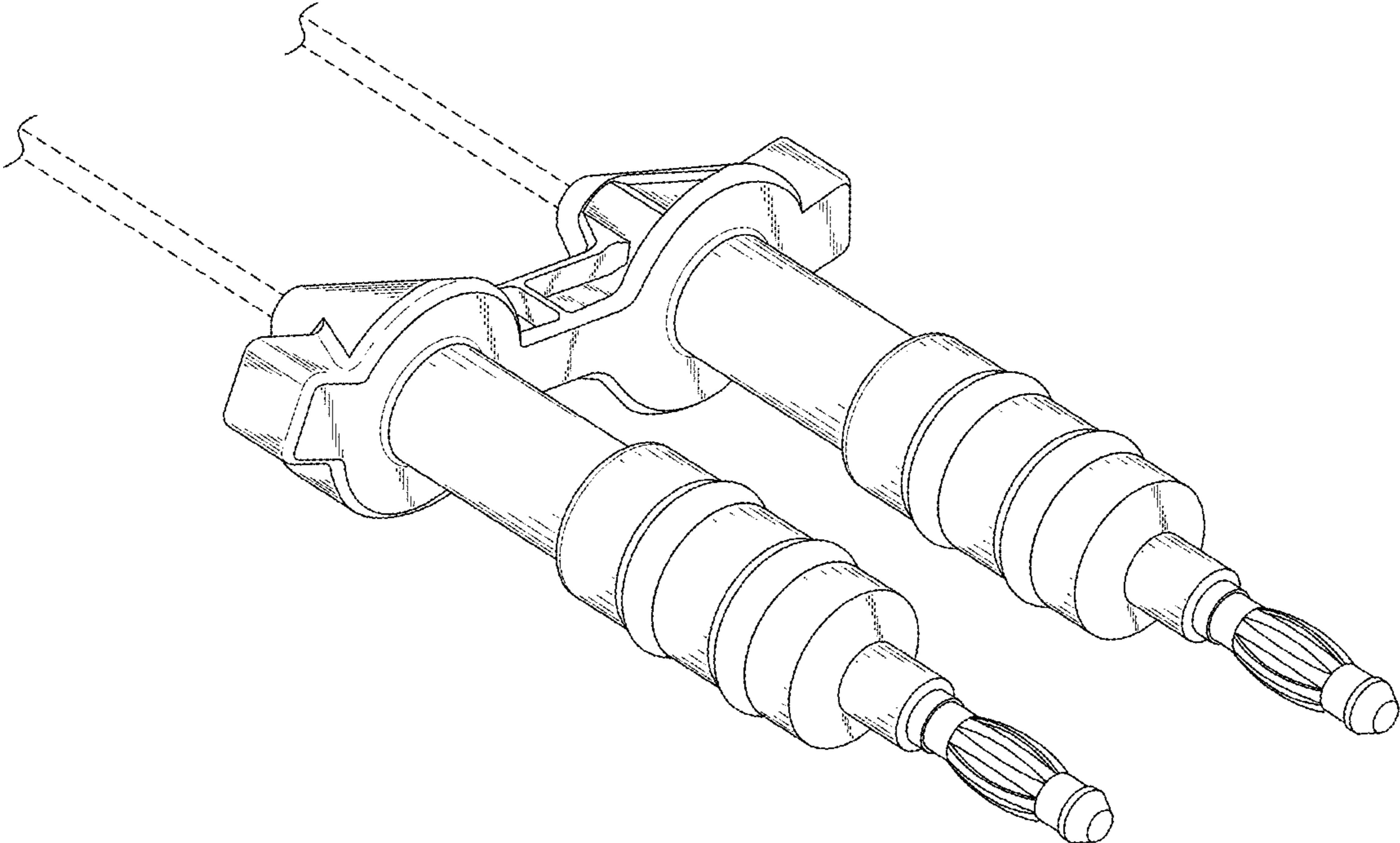
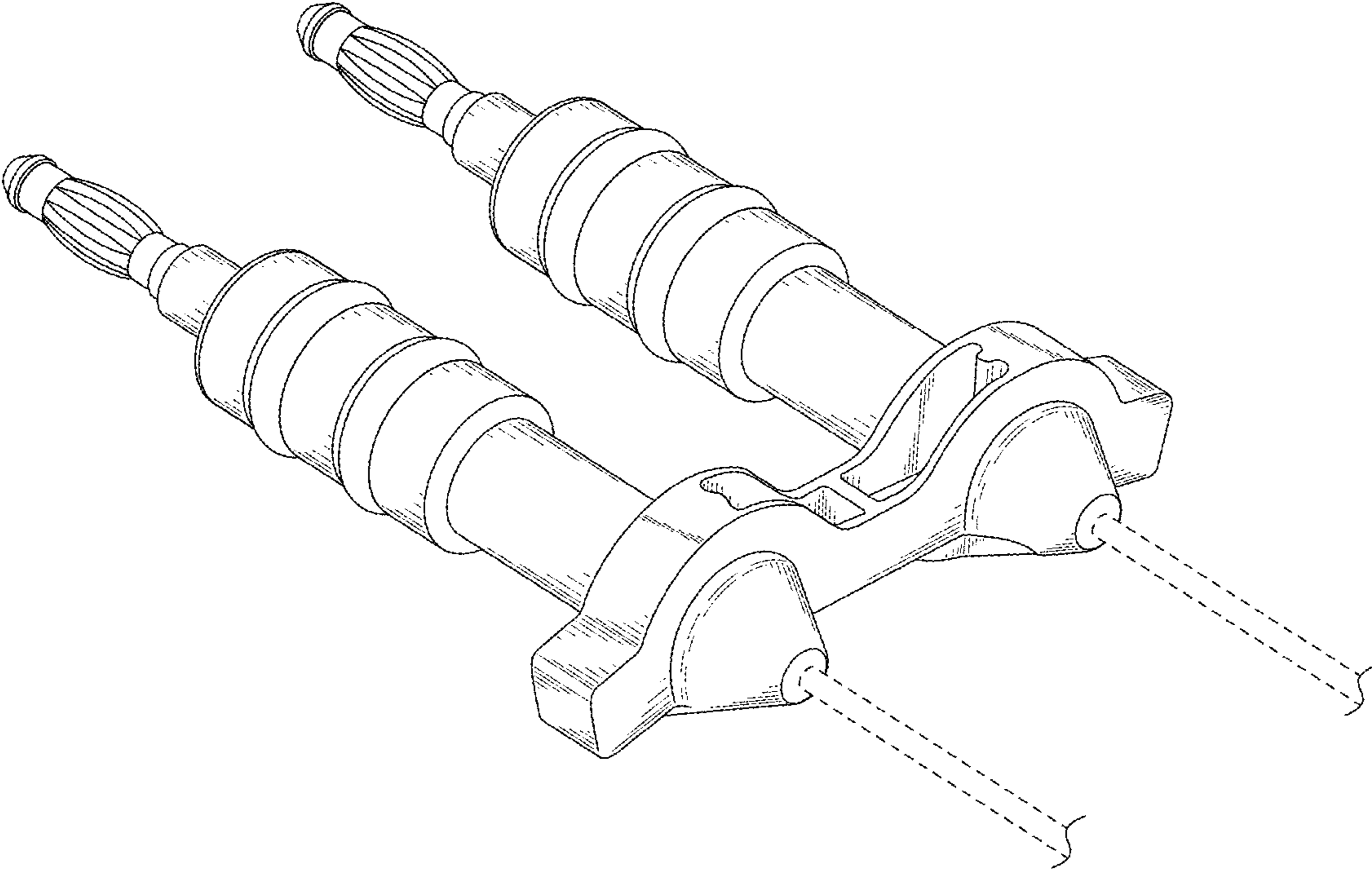

FIG. 1



**FIG. 2**

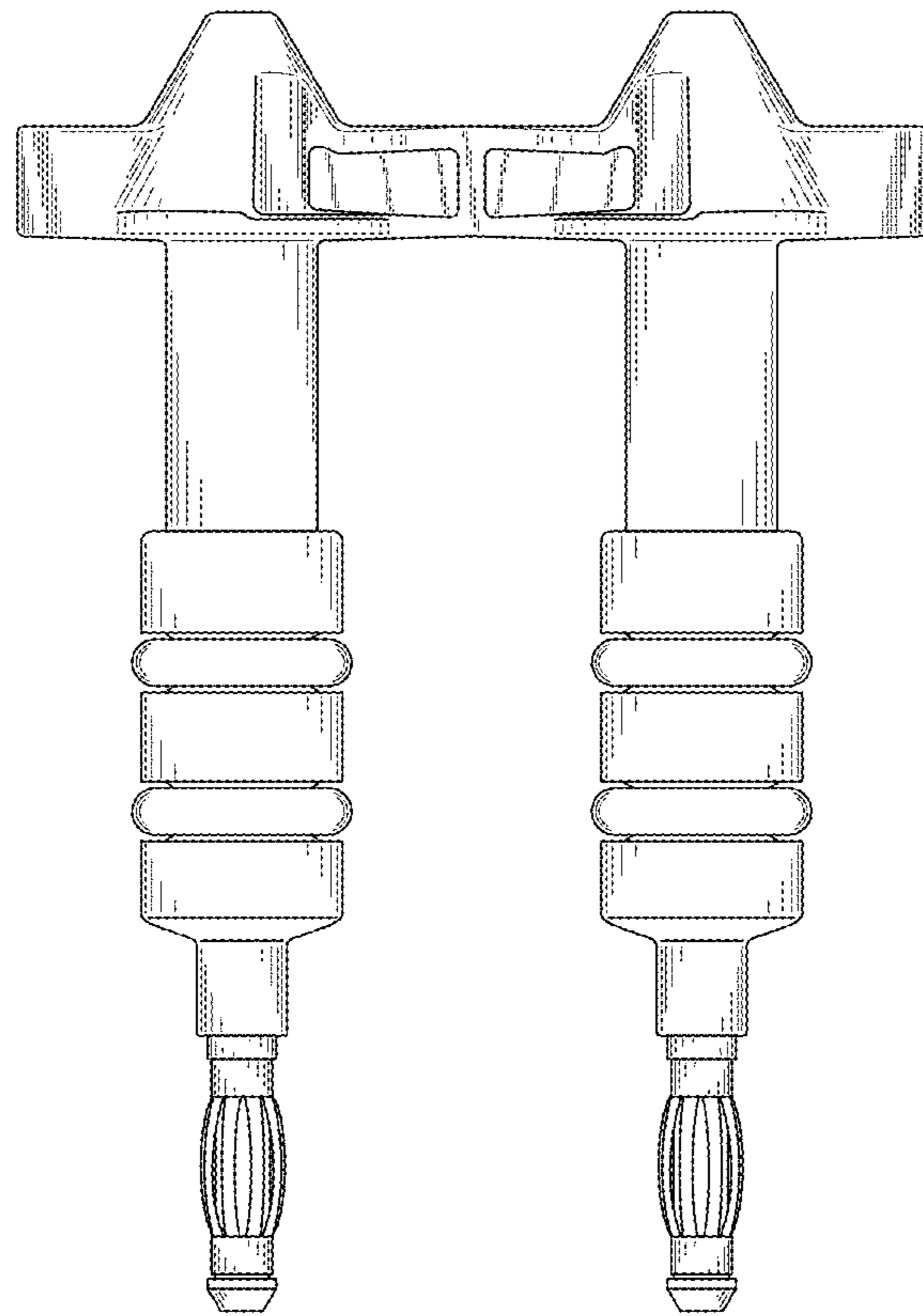

FIG. 3

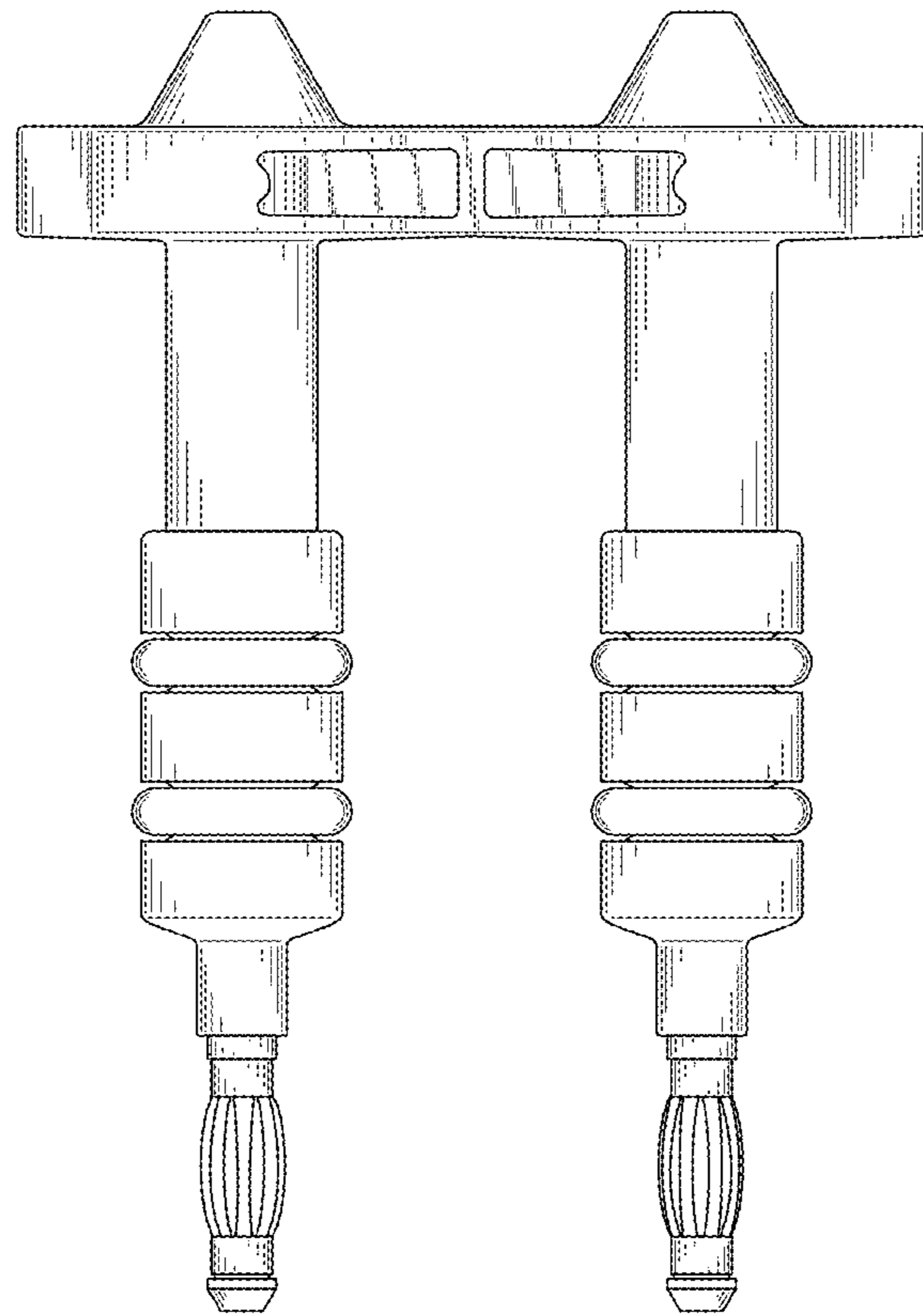
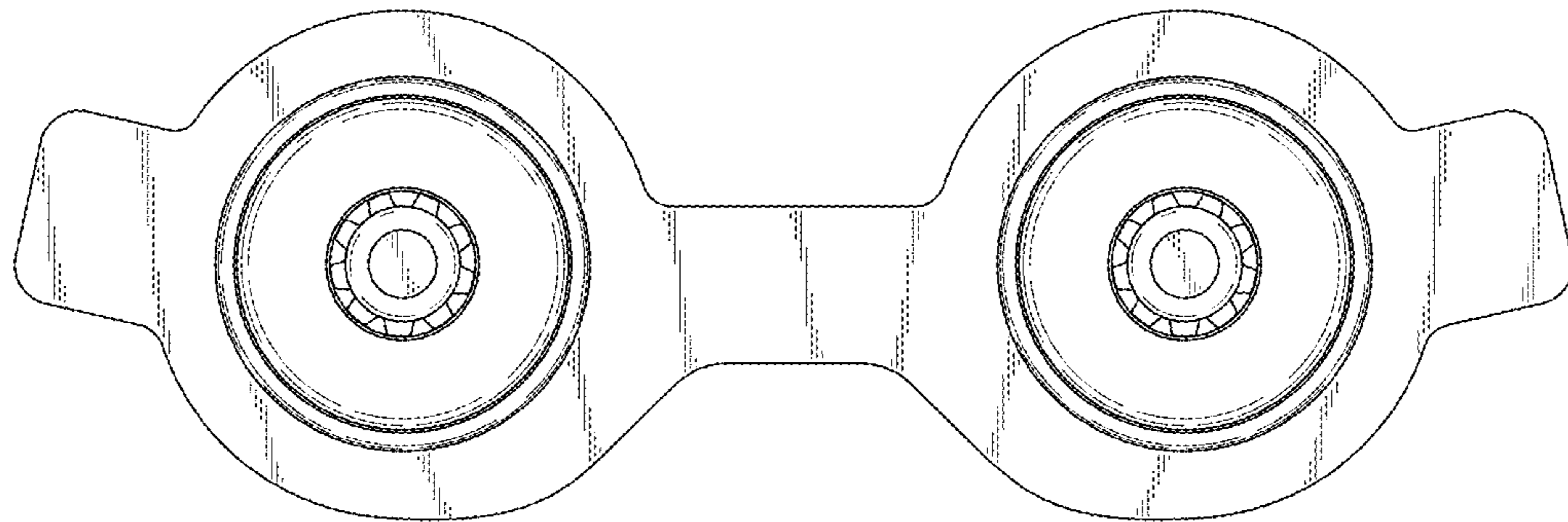
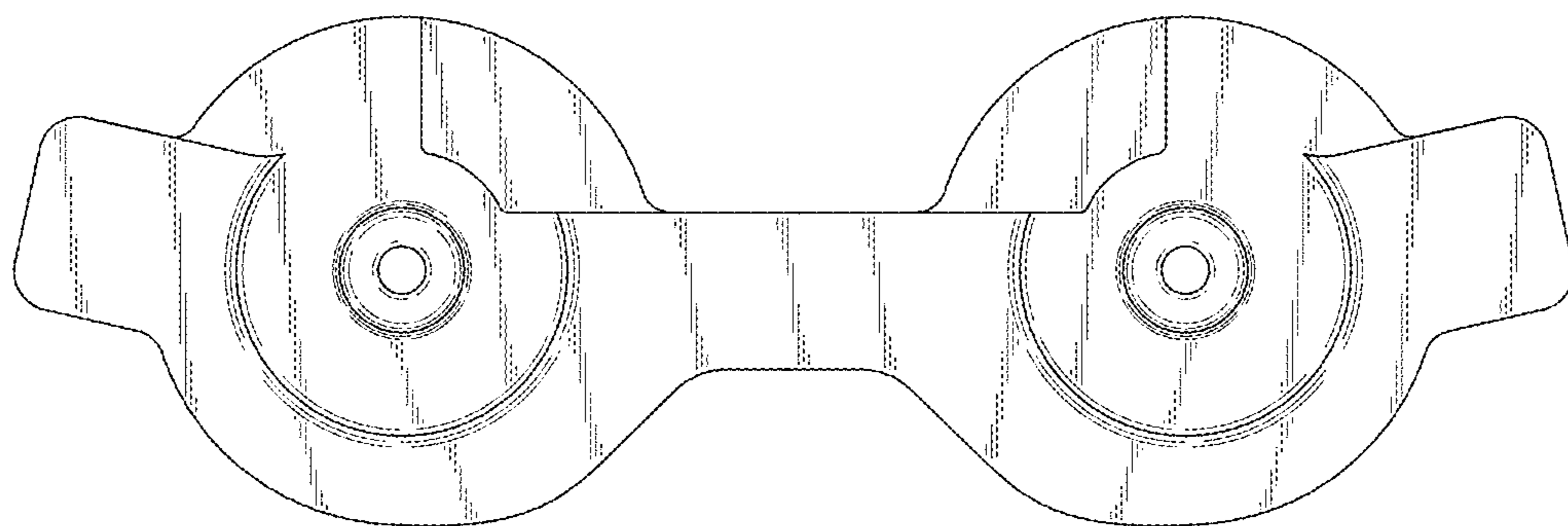

FIG. 4



**FIG. 5**



**FIG. 6**

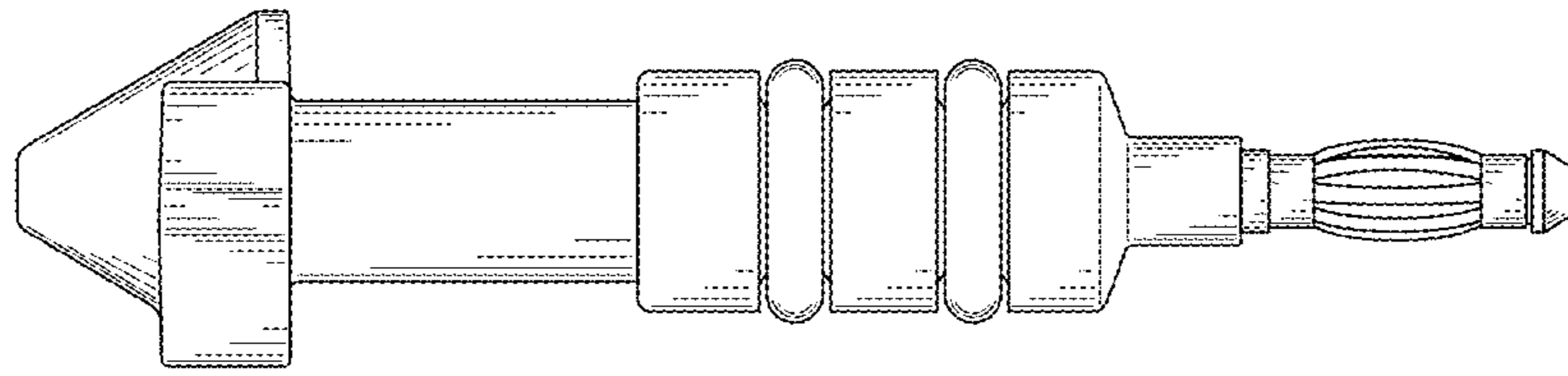

**FIG. 7**

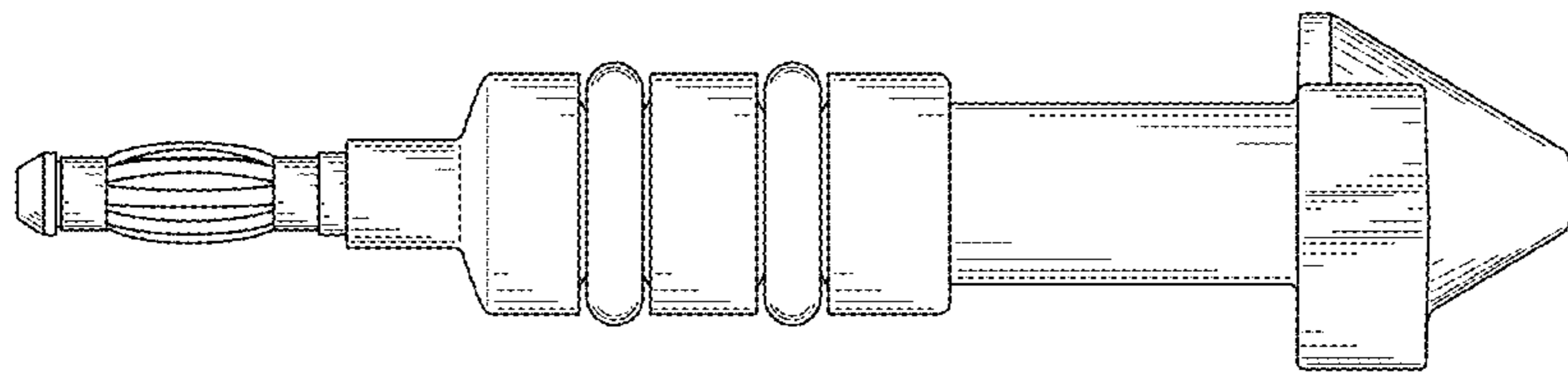

**FIG. 8**