



US00D985517S

(12) **United States Design Patent** (10) **Patent No.:** **US D985,517 S**
McPherson et al. (45) **Date of Patent:** **** May 9, 2023**

(54) **POWER MODULE HAVING PIN FINS**

- (71) Applicant: **WOLFSPEED, INC.**, Durham, NC (US)
- (72) Inventors: **Brice McPherson**, Fayetteville, AR (US); **Matthew Feurtado**, Fayetteville, AR (US)
- (73) Assignee: **WOLFSPEED, INC.**, Durham, NC (US)
- (**) Term: **15 Years**
- (21) Appl. No.: **29/821,330**
- (22) Filed: **Dec. 29, 2021**

Related U.S. Application Data

- (62) Division of application No. 29/710,592, filed on Oct. 24, 2019, now Pat. No. Des. 942,403.
- (51) **LOC (14) Cl.** **13-03**
- (52) **U.S. Cl.**
USPC **D13/179; D13/110**
- (58) **Field of Classification Search**
USPC D13/110, 123, 124, 158, 162, 179, 184
CPC H05K 5/00; H05K 5/0069; H05K 5/0247;
H05K 9/0037; H05K 7/1432; H03K
17/305; H01L 2223/6644; H02M 7/003
See application file for complete search history.

(56) **References Cited**

U.S. PATENT DOCUMENTS

D109,235 S 4/1938 Smith
3,421,578 A 1/1969 Marton
(Continued)

FOREIGN PATENT DOCUMENTS

JP D1411990 S 4/2011
JP D1495189 S 4/2014
(Continued)

OTHER PUBLICATIONS

“IGBT power semiconductor module” M & E, published by Kogyo Chosakai, vol. 33, No. 7, Jul. 1, 2006, p. 137, Product No. KAL100, Special License Office Design Division Publicly known document No. HA1800853600 [With machine-generated translation].
(Continued)

Primary Examiner — Selina Sikder
(74) *Attorney, Agent, or Firm* — BakerHostetler

(57) **CLAIM**

We claim the ornamental design for a power module having pin fins, as shown and described.

DESCRIPTION

FIG. 1 is a front right side perspective view of a power module having pin fins;
FIG. 2 is a bottom right side perspective view of the power module having pin fins shown in FIG. 1;
FIG. 3 is a top view of the power module having pin fins shown in FIG. 1;
FIG. 4 is a left side view of the power module having pin fins shown in FIG. 1;
FIG. 5 is a right side view of the power module having pin fins shown in FIG. 1;
FIG. 6 is a bottom view of the power module having pin fins shown in FIG. 1;
FIG. 7 is a back side view of the power module having pin fins shown in FIG. 1; and,
FIG. 8 is a front side view of the power module having pin fins shown in FIG. 1.
In the drawings, the claimed design is defined by the shaded surfaces; broken lines immediately adjacent shaded surfaces represent boundaries of the claim and form no part thereof; all other broken lines depict unclaimed environmental subject matter and form no part of the claim.

1 Claim, 8 Drawing Sheets

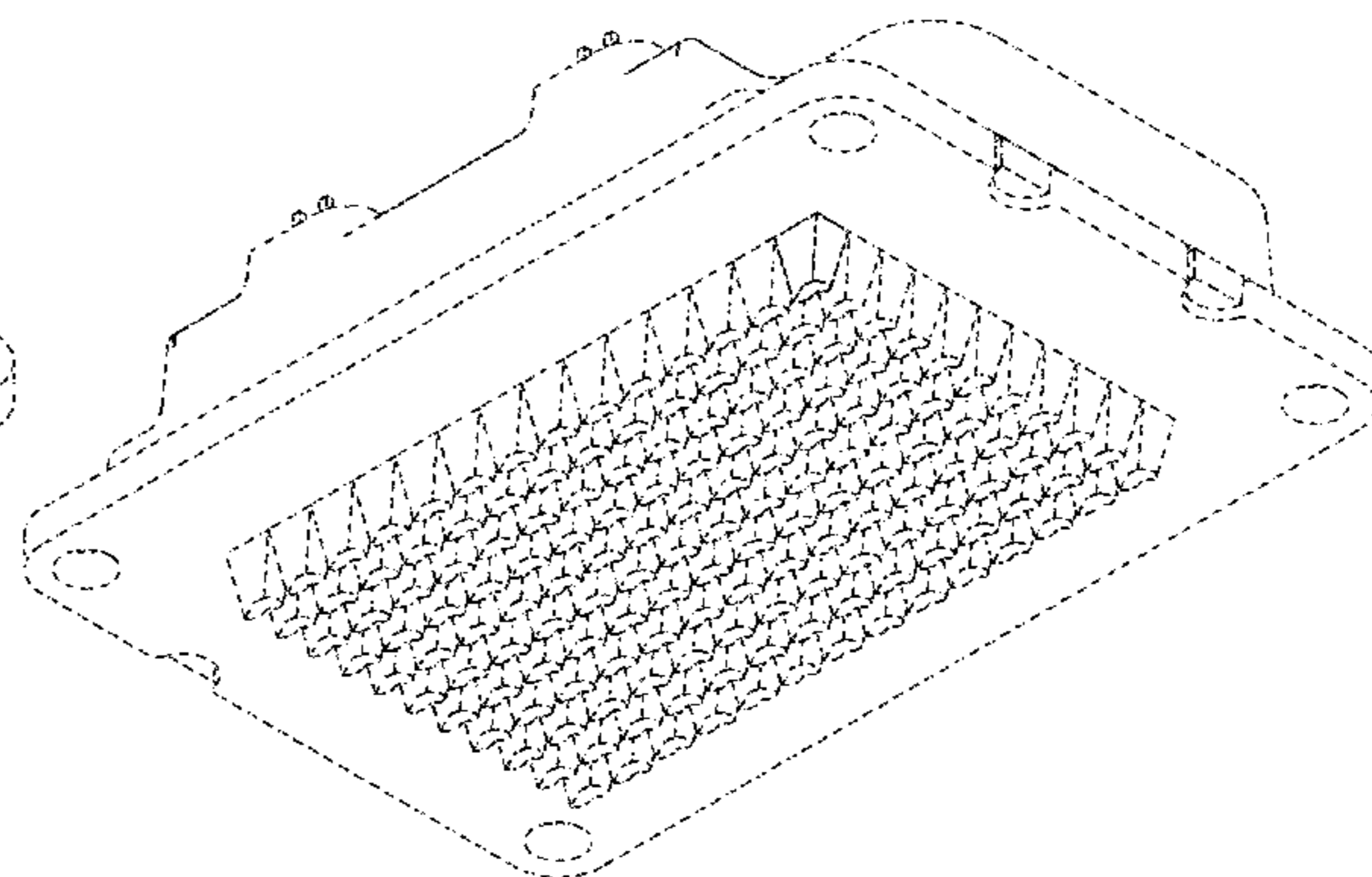
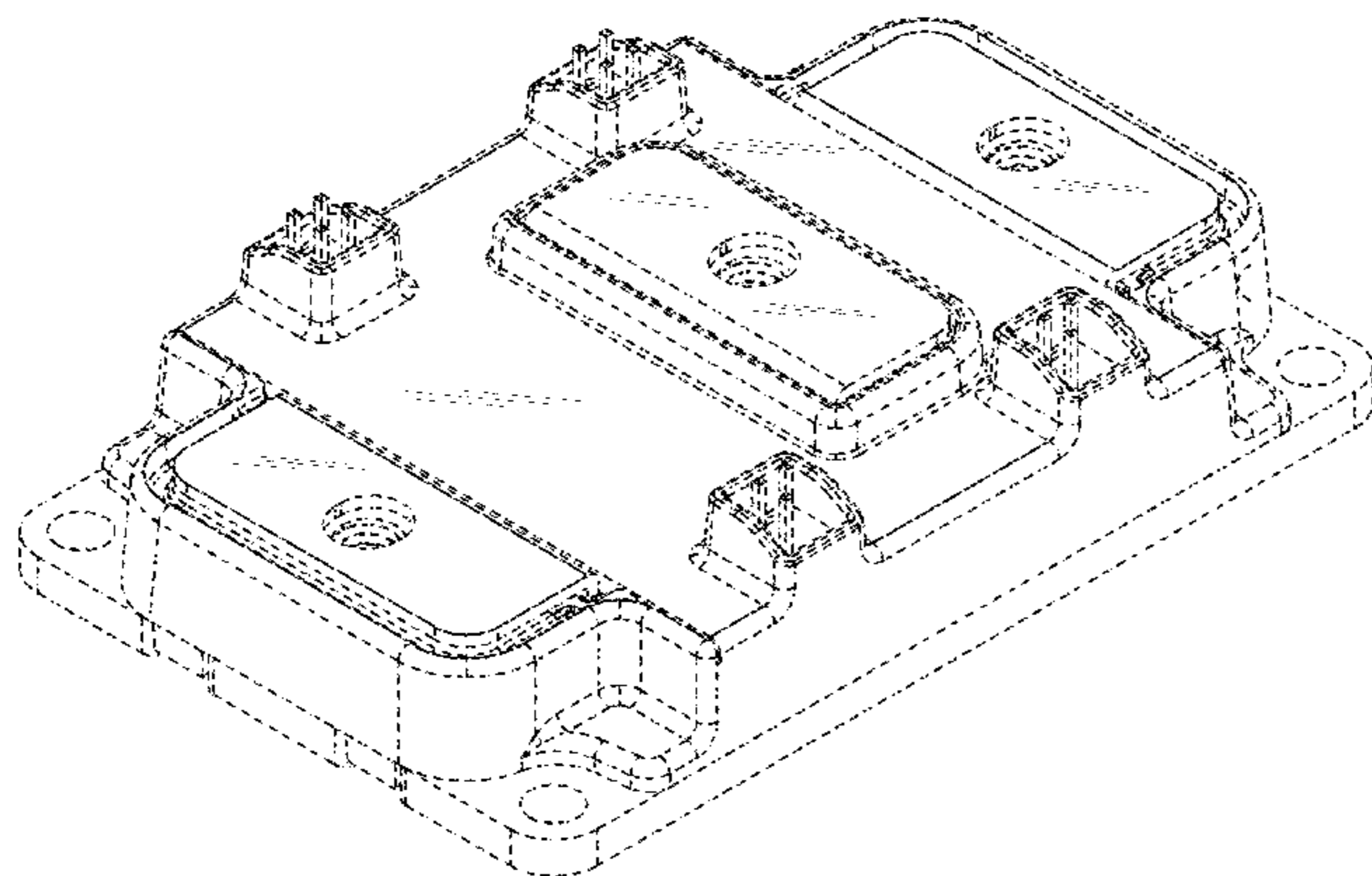

(56)

References Cited

U.S. PATENT DOCUMENTS

3,790,859	A	2/1974	Schraeder	
4,638,858	A	1/1987	Chu	
D291,845	S	9/1987	Lamborghini	
5,241,453	A	8/1993	Bright et al.	
D341,944	S	12/1993	Peter	
D364,385	S	11/1995	Shimizu et al.	
5,725,051	A	3/1998	Veltkamp	
D398,295	S	9/1998	Chang	
6,601,299	B2	8/2003	Stikeleather	
6,952,347	B2	10/2005	Baeumel et al.	
D511,251	S	11/2005	Wong	
D611,255	S	3/2010	Ko et al.	
7,751,192	B2	7/2010	Abul-Haj et al.	
D622,228	S	8/2010	Huang et al.	
D622,230	S	8/2010	Yan et al.	
D627,746	S	11/2010	Yan et al.	
D672,154	S	12/2012	Huss et al.	
D672,729	S	12/2012	Lin	
D673,124	S	12/2012	Lin	
8,441,275	B1	5/2013	Alladio	
D699,908	S	2/2014	Fang	
D719,537	S	12/2014	Kawase et al.	
9,255,745	B2	2/2016	Bertolotti et al.	
9,291,404	B2	3/2016	Tamura et al.	
D757,450	S	5/2016	Sierra et al.	
D772,184	S	11/2016	Soyano et al.	
D775,091	S	12/2016	Edenharter et al.	
D810,706	S	2/2018	Soyano et al.	
D822,626	S	7/2018	Reilly et al.	
10,020,237	B2	7/2018	Hoehn et al.	
10,297,525	B2	5/2019	Gong et al.	
10,302,371	B2	5/2019	Kadijk et al.	
D903,590	S	12/2020	McPherson et al.	
10,957,621	B2	3/2021	Williams	
11,071,234	B2	7/2021	Huitink et al.	
11,078,847	B2	8/2021	Porter et al.	
D942,403	S *	2/2022	McPherson D13/110	
2004/0150956	A1	8/2004	Conte	
2007/0119568	A1	5/2007	Weber et al.	
2008/0066888	A1	3/2008	Tong et al.	

2009/0145581	A1	6/2009	Hoffman et al.
2009/0309524	A1	12/2009	Rider et al.
2012/0001227	A1	1/2012	Takahashi et al.
2012/0207591	A1	8/2012	Lee et al.
2013/0105961	A1	5/2013	Jones et al.
2014/0029199	A1	1/2014	Dede
2014/0091453	A1	4/2014	Mori et al.
2014/0198475	A1	7/2014	Menzies et al.
2014/0376184	A1	12/2014	Gohara
2015/0137871	A1	5/2015	Takano
2015/0146377	A1	5/2015	You et al.
2015/0327394	A1	11/2015	Davis et al.
2020/0102839	A1	4/2020	Heneveld
2020/0144140	A1	5/2020	Trussel et al.
2020/0388556	A1	12/2020	Tsuyuno
2021/0285727	A1	9/2021	Aute et al.

FOREIGN PATENT DOCUMENTS

JP	D1495703	S	4/2014
JP	D1530509	S	8/2015
JP	D1660547	S	6/2020
JP	D1660592	S	6/2020
JP	D1660593	S	6/2020
KR	30-0236239	S	5/1999
KR	30-0255614	S	4/2000

OTHER PUBLICATIONS

“Semiconductor devices for electric power” 2003 CVCF constant voltage, constant frequency uninterruptible power supply (UPS) catalog, 2004, Domestic Catalog No. 262, p. 3, Public Document No. HC1605031600, Design Division, Japan Patent Office; retrieved from the Internet on Mar. 1, 2005 [With machine-generated translation].
 German Design Bulletin, vol. 3, Feb. 25, 1995, p. 979, Register No. M9407438, Design Nos. M9407438-0001, M9407438-0002 and M9407438-0003; Public Document No. HH08013675, Design Division, Japan Patent Office [With machine-generated translation].

* cited by examiner

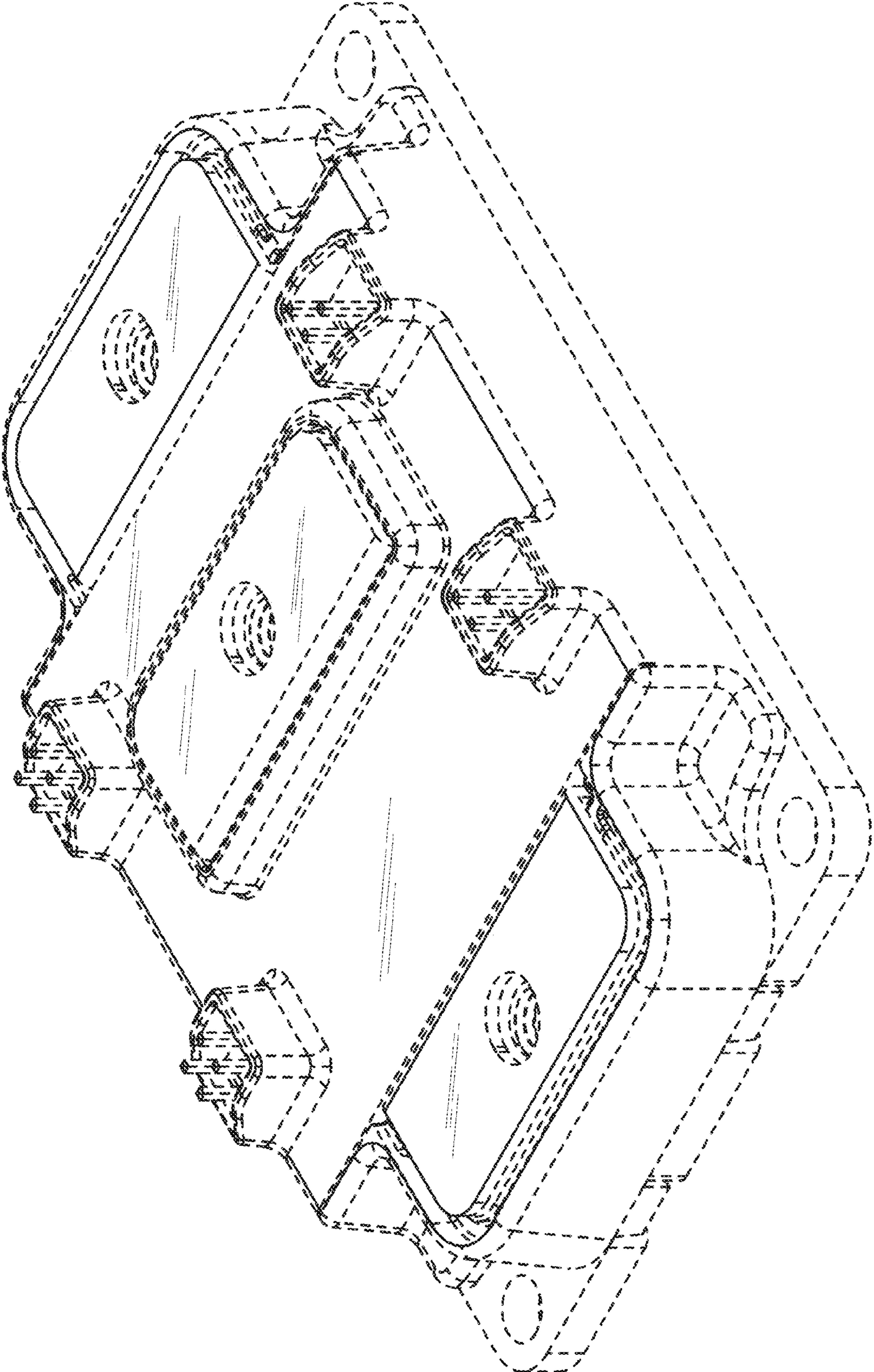

FIG. 1

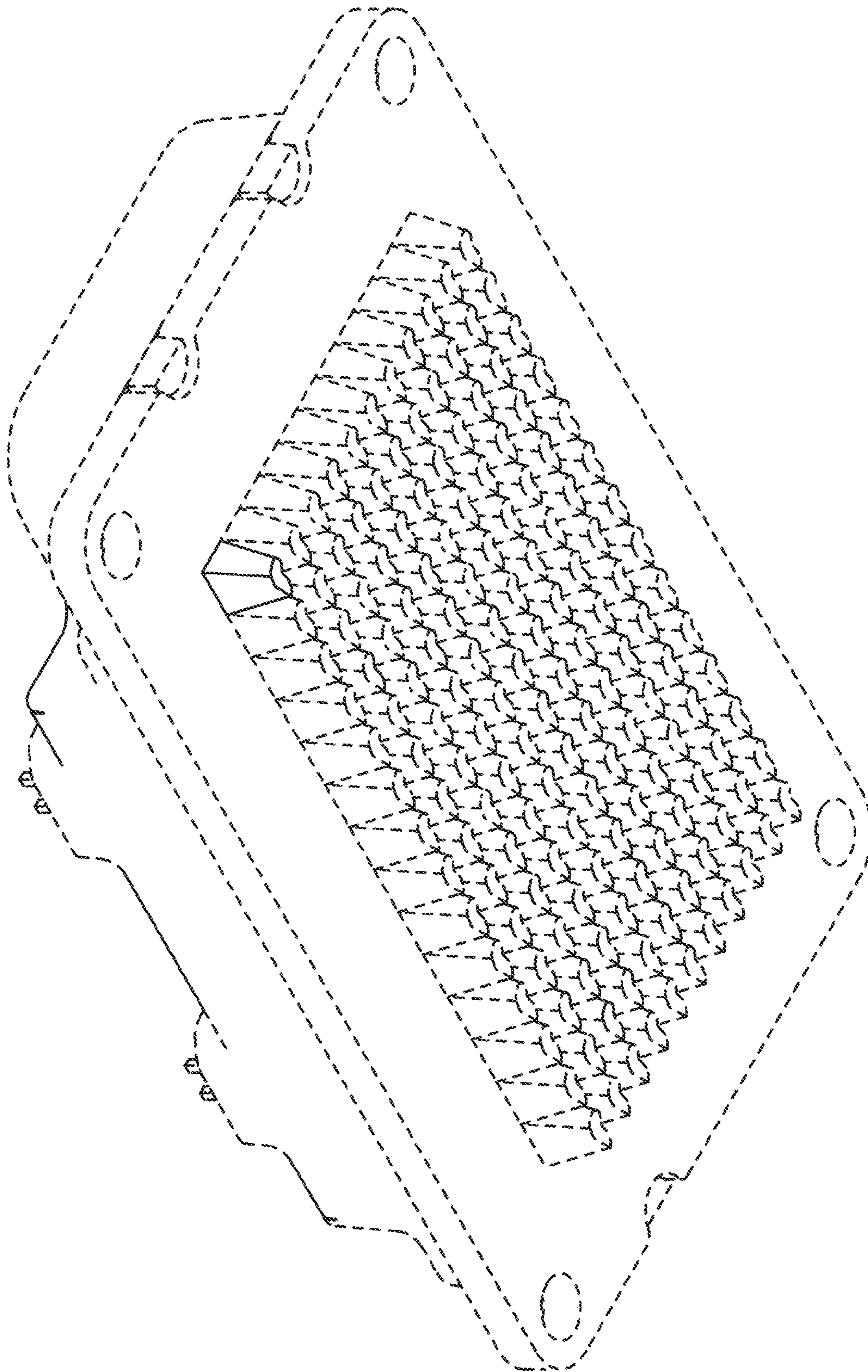

FIG. 2

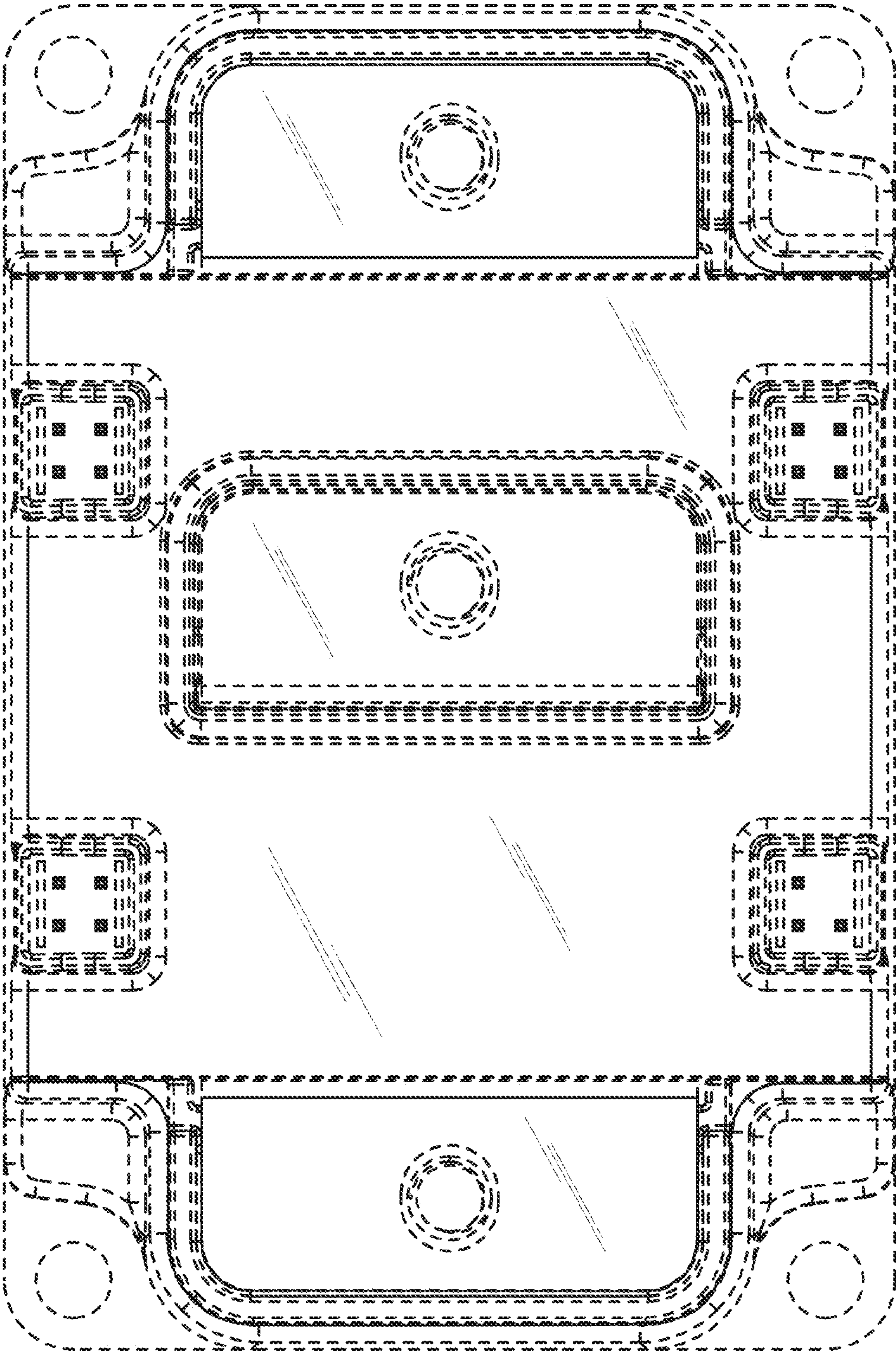

FIG. 3

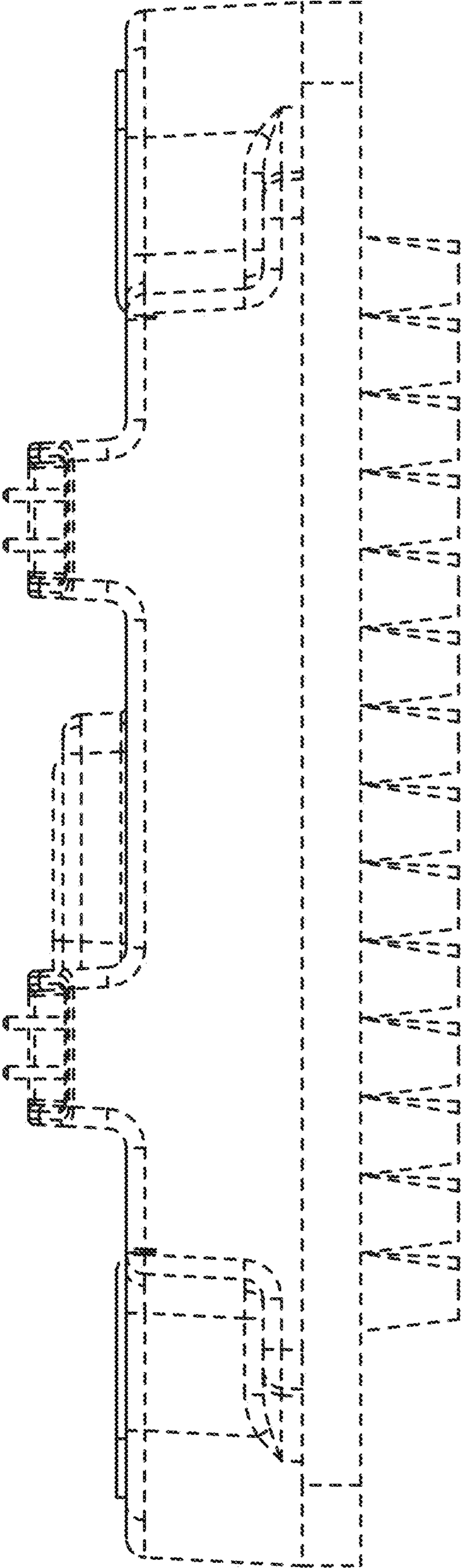

FIG. 4

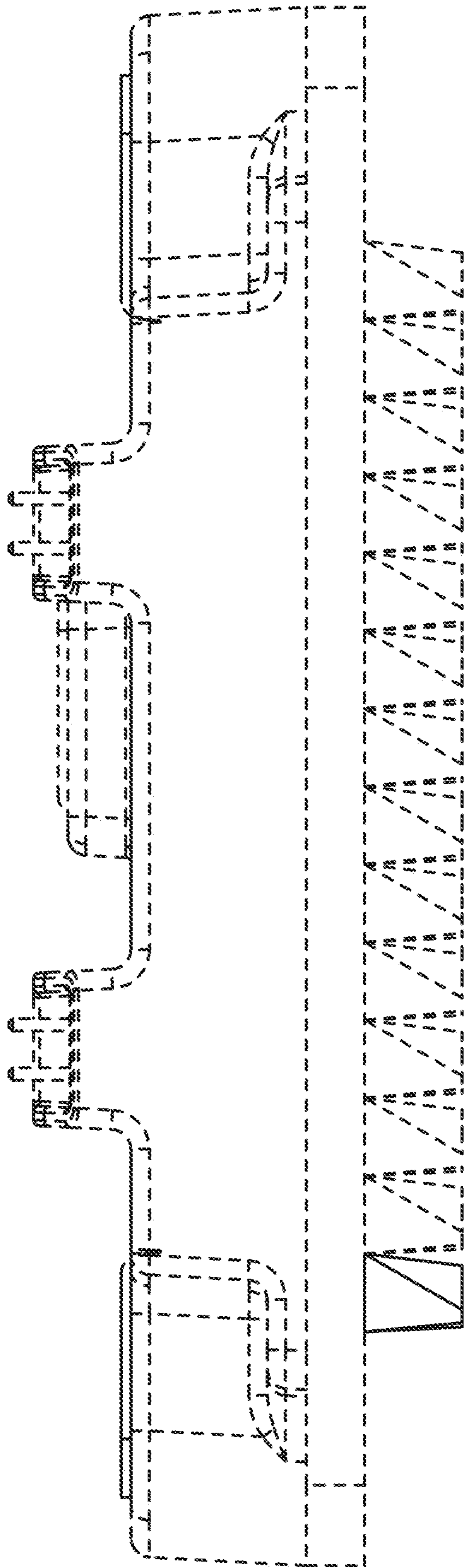

FIG. 5

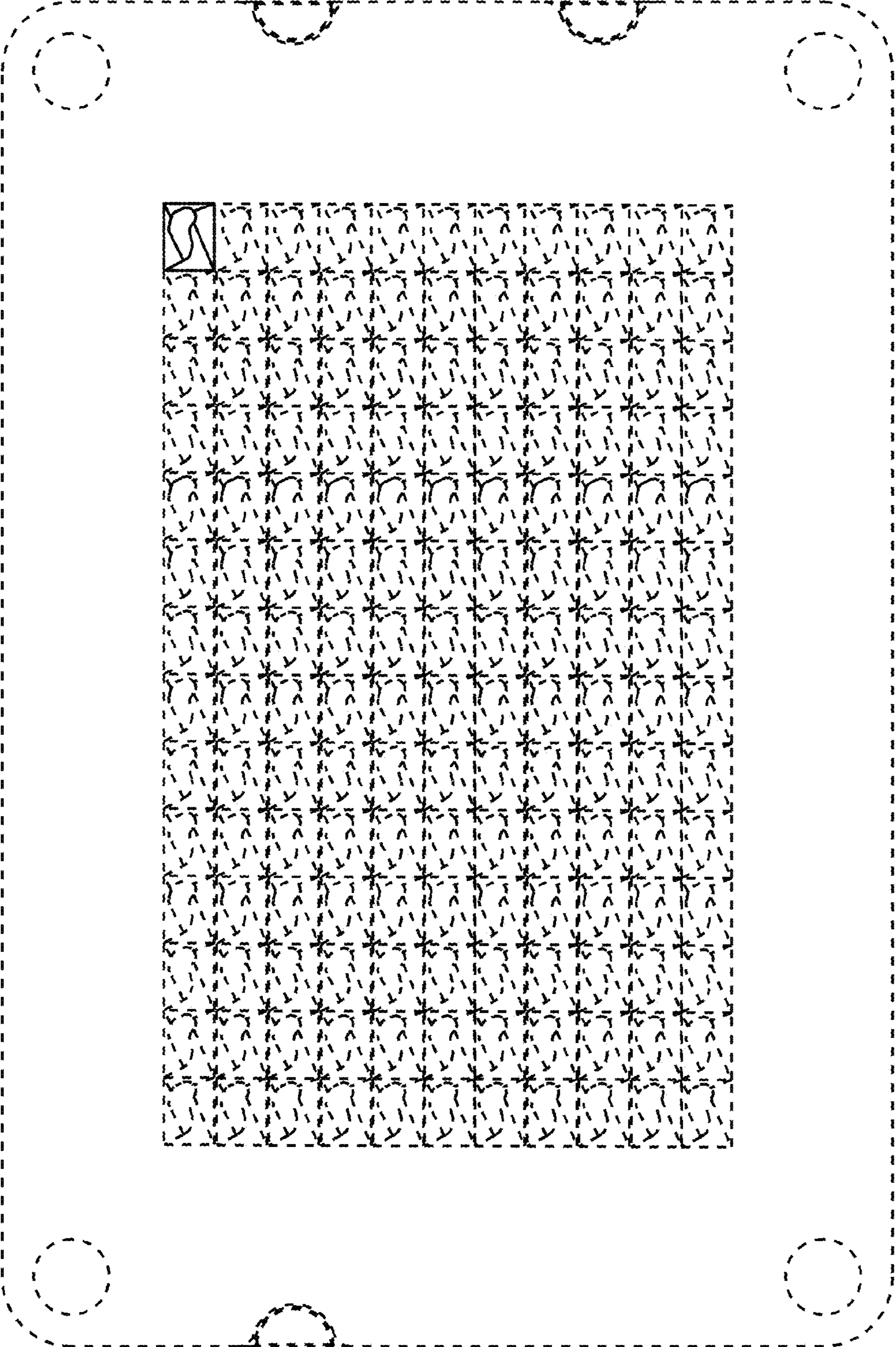

FIG. 6

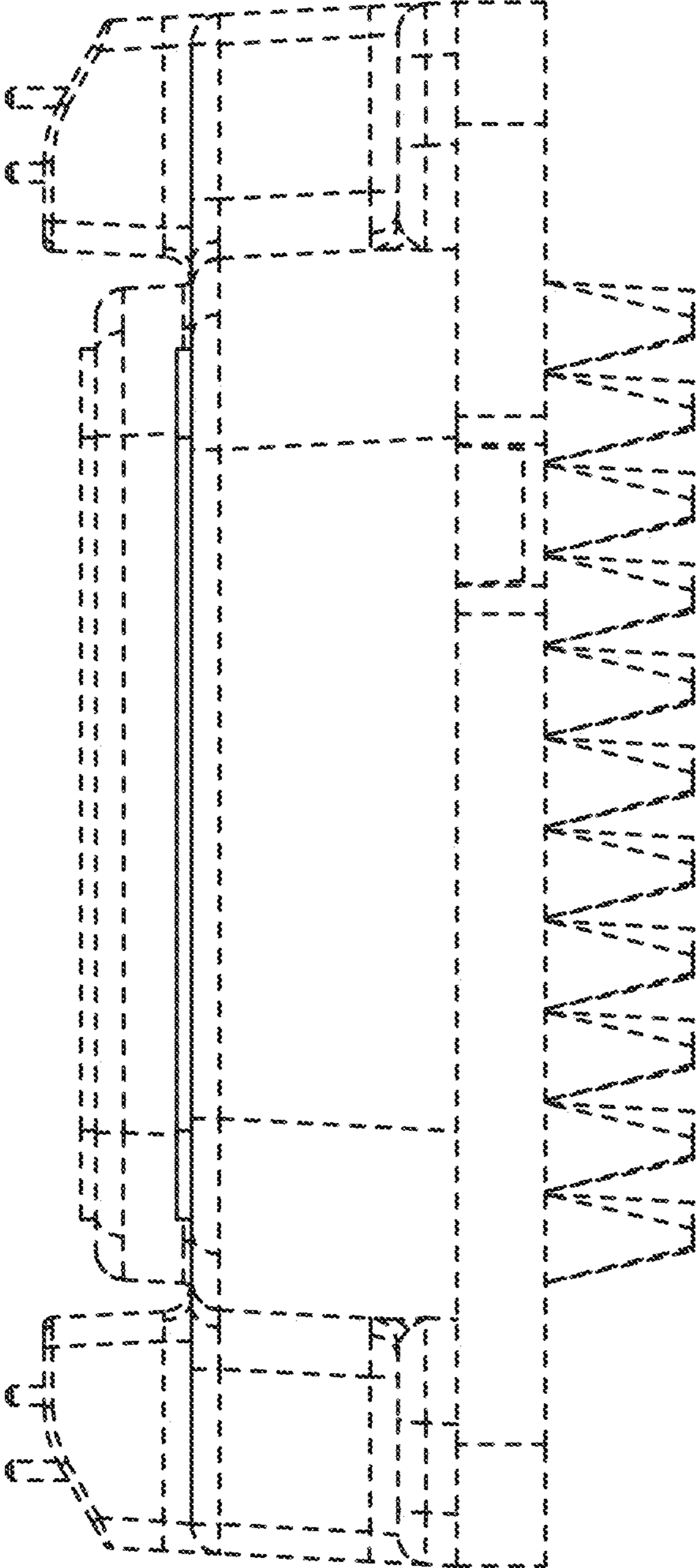

FIG. 7

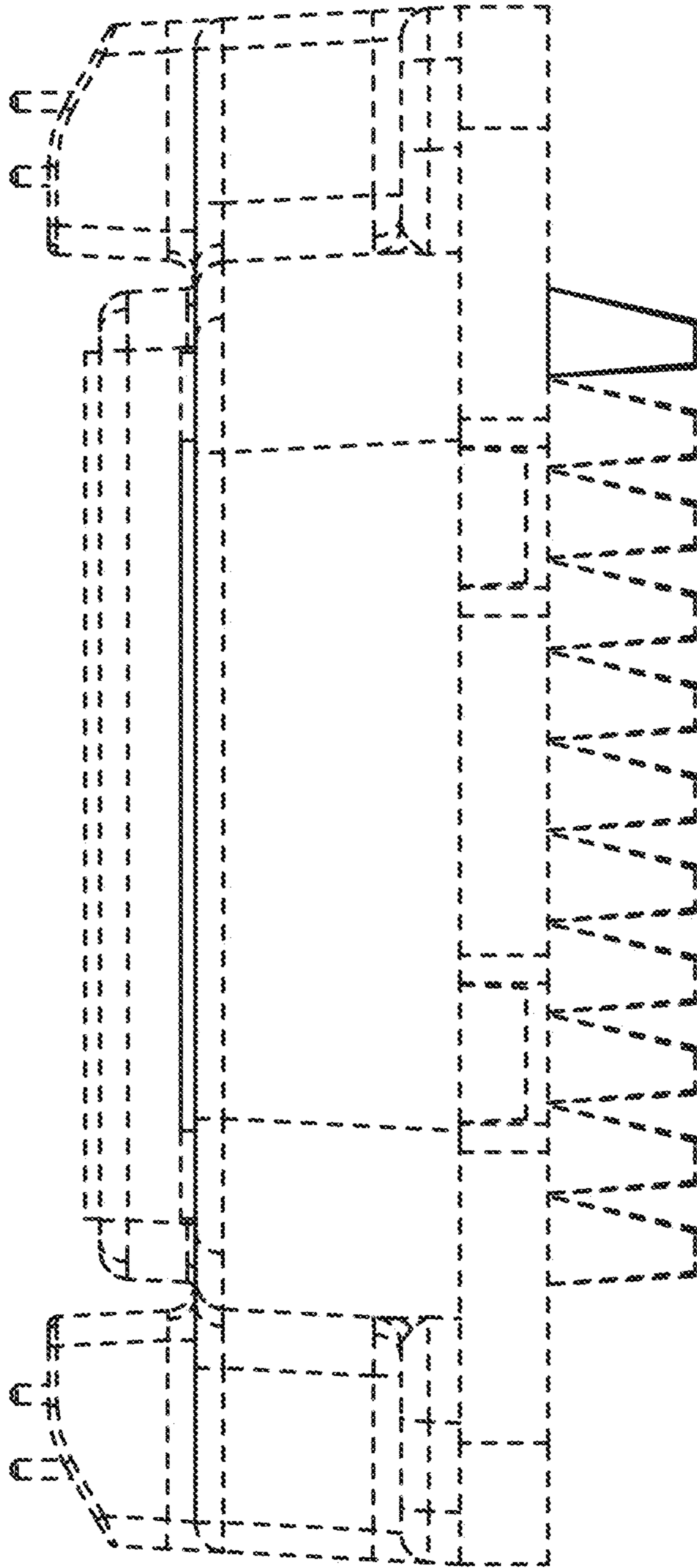

FIG. 8