



US00D985376S

(12) **United States Design Patent**
Jie et al.

(10) **Patent No.:** **US D985,376 S**

(45) **Date of Patent:** **** May 9, 2023**

(54) **TRIPLE WHEEL CASTER**

(71) Applicants: **Yebing Jie**, Fujian (CN); **Xiaolin Shen**, Fujian (CN); **Jingduan Chen**, Fujian (CN)

(72) Inventors: **Yebing Jie**, Fujian (CN); **Xiaolin Shen**, Fujian (CN); **Jingduan Chen**, Fujian (CN)

(73) Assignee: **Angellun (Fuzhou) Propulsion Technology Co., Ltd**, Fuzhou (CN)

(**) Term: **15 Years**

(21) Appl. No.: **29/804,242**

(22) Filed: **Aug. 19, 2021**

(30) **Foreign Application Priority Data**

Jun. 29, 2021 (CN) 202130404237.7

(51) **LOC (14) Cl.** **08-11**

(52) **U.S. Cl.**
USPC **D8/375**

(58) **Field of Classification Search**

USPC D8/375, 397, 398, 396, 377, 376;
D12/131, 204, 205, 206, 207, 213, 133
CPC A61G 5/00-14; B62B 5/0083; B60B
33/0028; B60B 33/001; B60B 33/0073;
B60B 33/0049; B60B 33/0057; B60B
33/0002; B60B 33/0068; B60B 33/0039;
B60B 33/0021; A47C 7/006
See application file for complete search history.

(56) **References Cited**

U.S. PATENT DOCUMENTS

D308,815 S * 6/1990 Caruso D8/375
D347,162 S * 5/1994 Simonsen D8/375

D573,010 S * 7/2008 Lin D8/375
D653,526 S * 2/2012 Melara D8/375
D741,431 S * 10/2015 Wells D21/765
D802,930 S * 11/2017 Morszeck D8/375
D802,931 S * 11/2017 Morszeck D8/375
D802,932 S * 11/2017 Morszeck D8/375
D901,283 S * 11/2020 Chen D8/375
D928,598 S * 8/2021 Aubin D8/375
D936,466 S * 11/2021 Hozumi D8/375
2015/0258850 A1 * 9/2015 Schioppa B60B 33/025
16/37

FOREIGN PATENT DOCUMENTS

EM 0086688830001 * 8/2021
JP D171239 * 8/2021

* cited by examiner

Primary Examiner — Eliza Z Harvey

Assistant Examiner — Kayla Marie Bennett

(57) **CLAIM**

The ornamental design for a triple wheel caster, as shown and described.

DESCRIPTION

FIG. 1 is a top, front, left side perspective view of a triple wheel caster showing our new design;
FIG. 2 is an enlarged front elevation view thereof;
FIG. 3 is an enlarged rear elevation view thereof;
FIG. 4 is a left side elevation view thereof, the right side elevation view being a mirror image of the left side elevation view;
FIG. 5 is a top plan view thereof; and,
FIG. 6 is a bottom plan view thereof.
The broken lines in the drawings illustrate portions of the triple wheel caster that form no part of the claimed design.

1 Claim, 6 Drawing Sheets

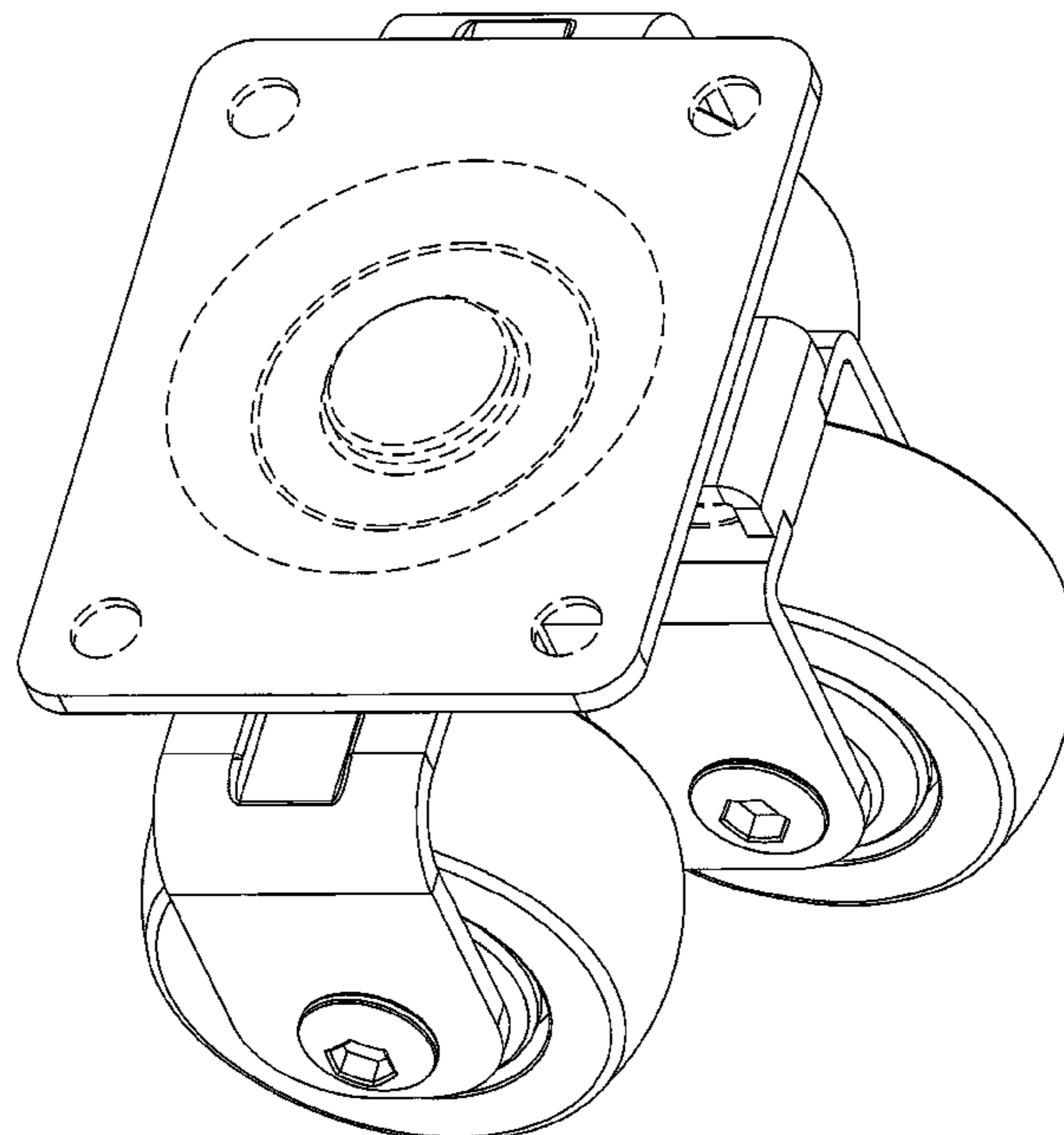

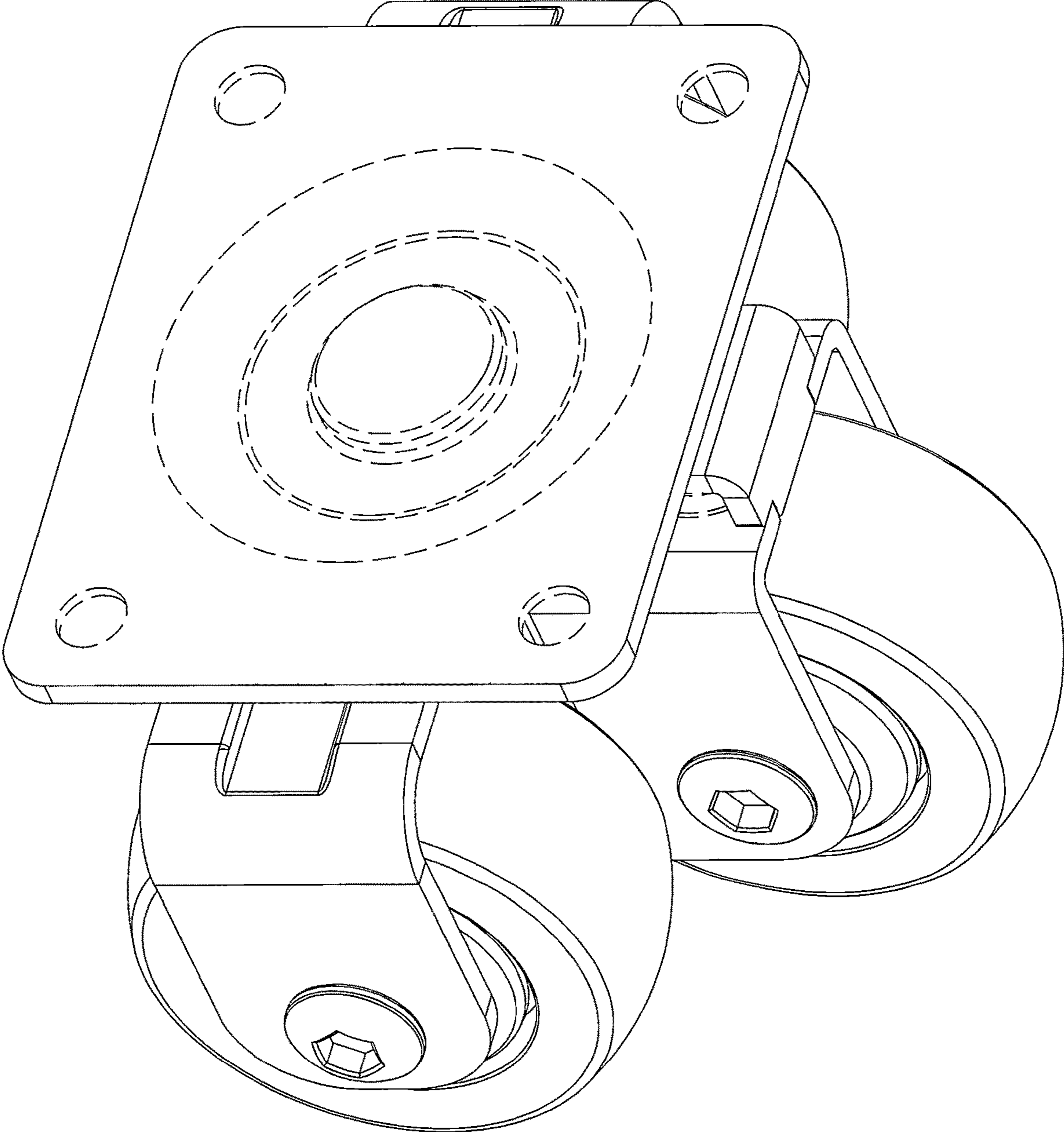

FIG.1

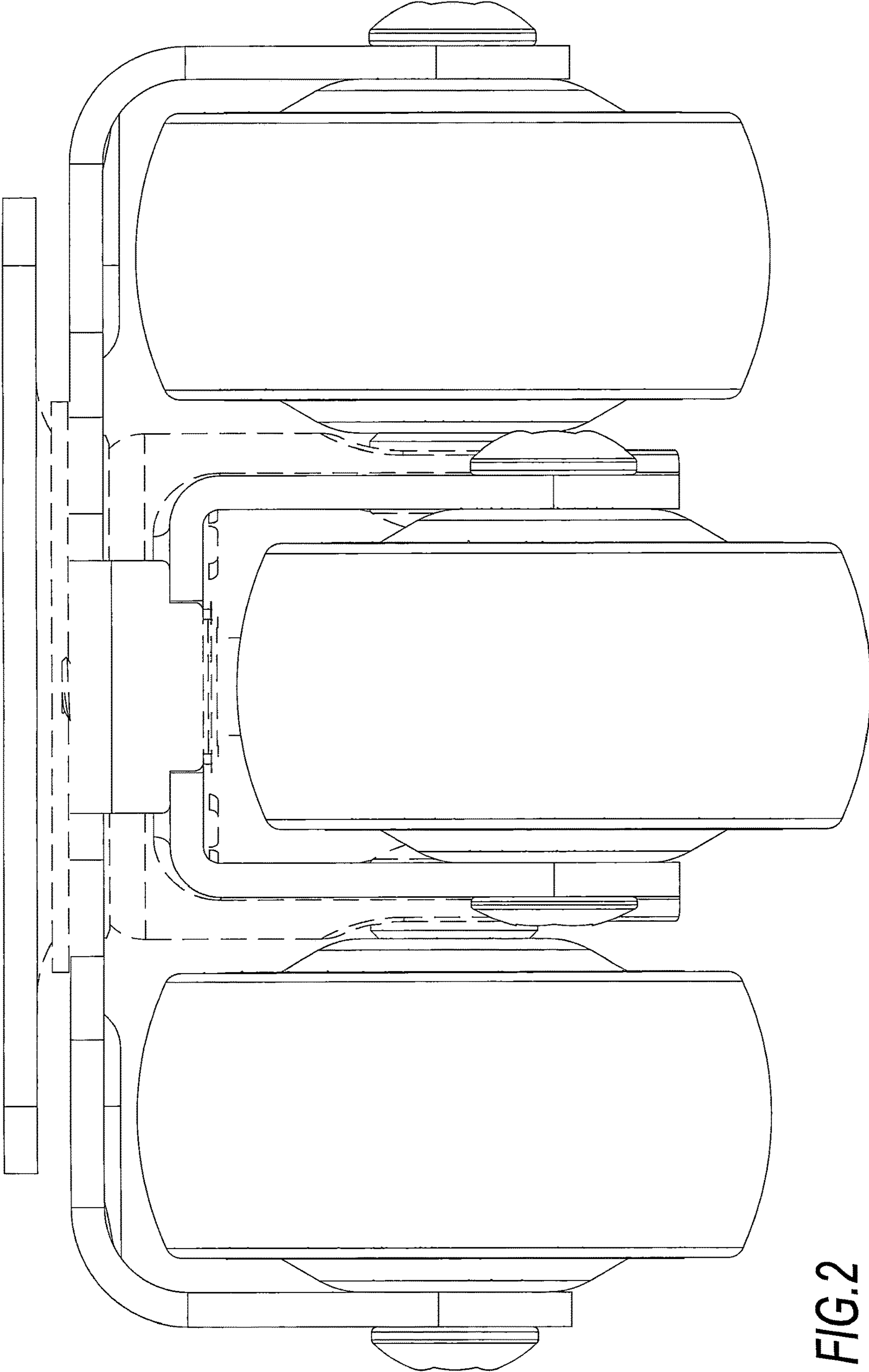

FIG.2

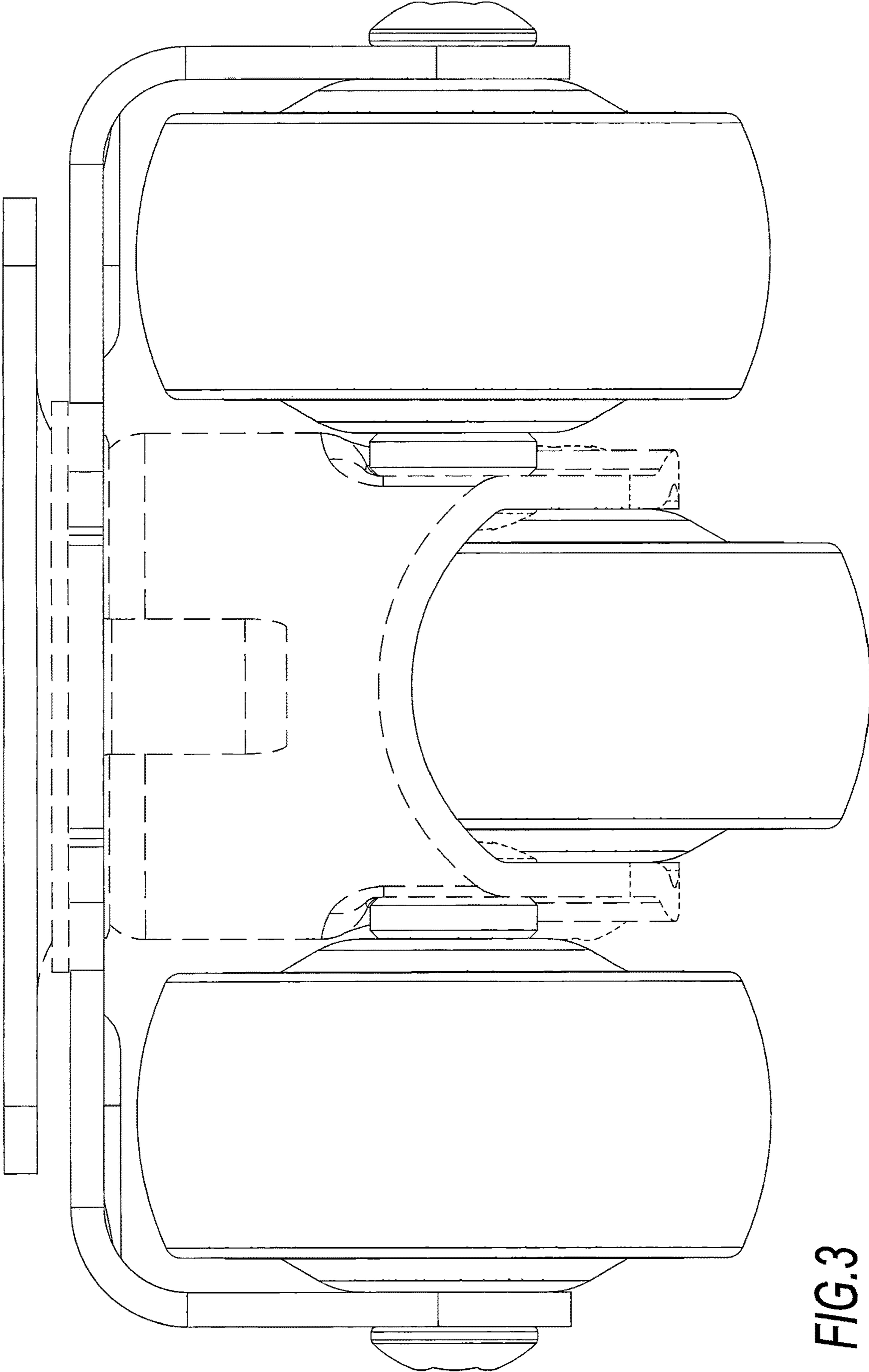

FIG. 3

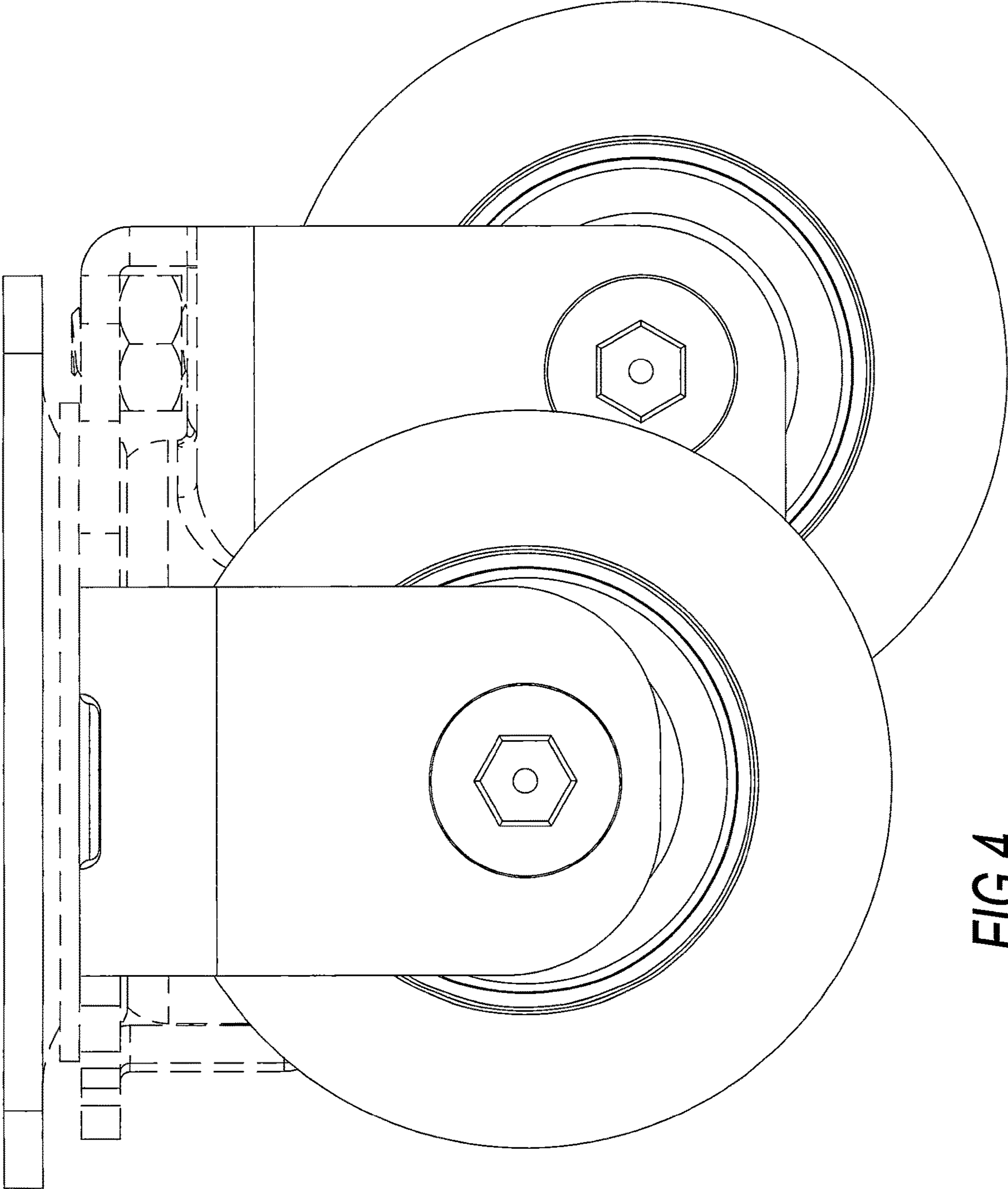

FIG.4

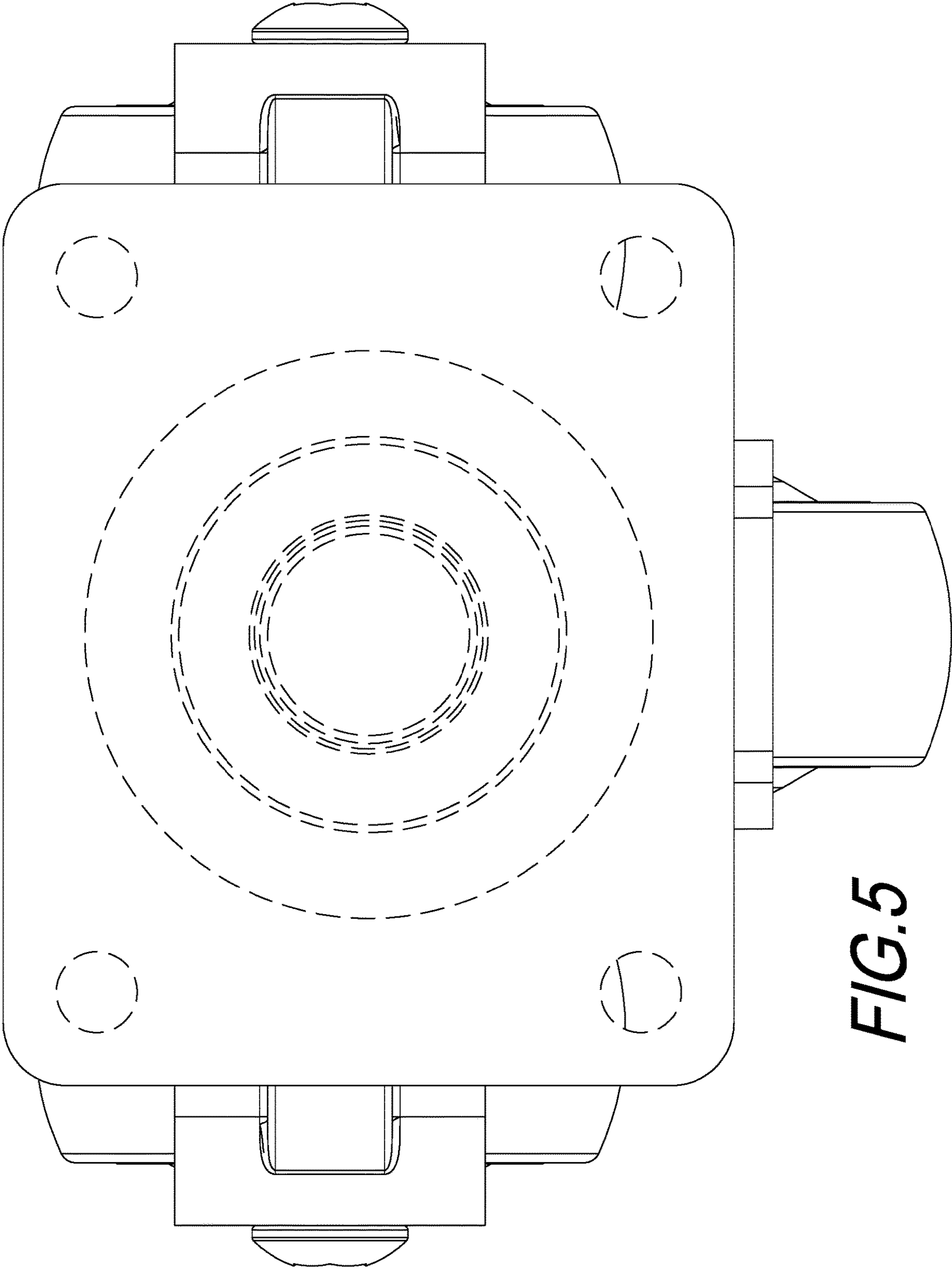

FIG. 5

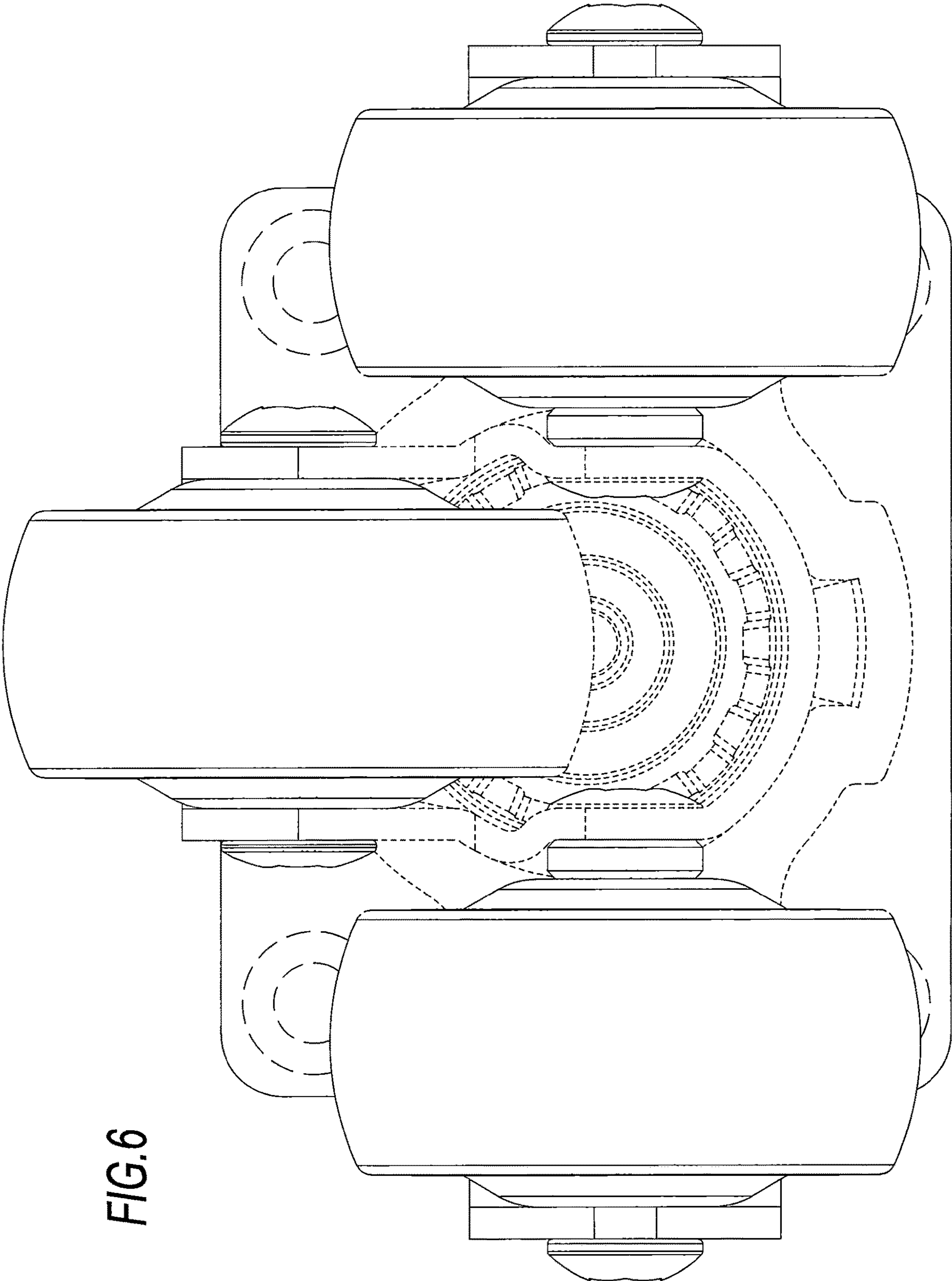

FIG.6