



US00D985178S

(12) **United States Design Patent**
Danforth

(10) **Patent No.:** **US D985,178 S**

(45) **Date of Patent:** **** May 2, 2023**

(54) **RED-LIGHT UNIT**

(71) Applicant: **David B Danforth**, Brandon, MS (US)

(72) Inventor: **David B Danforth**, Brandon, MS (US)

(**) Term: **15 Years**

(21) Appl. No.: **29/827,757**

(22) Filed: **Feb. 22, 2022**

(51) **LOC (14) Cl.** **26-05**

(52) **U.S. Cl.**
USPC **D26/104**

(58) **Field of Classification Search**
USPC D26/1, 24, 28, 88, 93, 94, 106, 104, 110,
D26/118

CPC F21S 6/00; F21S 6/002; F21V 3/00; F21W
2121/00; F21W 2131/00

See application file for complete search history.

D842,532 S *	3/2019	Reynolds	D26/118
D930,867 S	9/2021	Ormsbee et al.		
D930,869 S	9/2021	Mundhra et al.		
D930,883 S	9/2021	Sonneman		
D930,884 S	9/2021	Xu		
D945,671 S *	3/2022	Liao	D25/135
D959,720 S *	8/2022	Liao	D25/135
2006/0283493 A1	12/2006	Charles		
2011/0010014 A1	1/2011	Oexman et al.		

* cited by examiner

Primary Examiner — Nathan M Johnston

(74) *Attorney, Agent, or Firm* — Suzanne Kikel, Patent Agent

(57) **CLAIM**

The ornamental design for a red-light unit, as shown and described.

(56) **References Cited**

U.S. PATENT DOCUMENTS

D165,259 S *	11/1951	Baker	D26/74
2,884,666 A	5/1959	Paulsen		
3,745,327 A *	7/1973	Lowery	F21S 8/033
				D26/80
D232,376 S *	8/1974	Yabraus	D26/24
D243,473 S *	2/1977	Freeman	D26/112
D442,731 S *	5/2001	Serrano	D26/104
D527,482 S *	8/2006	Bucher	D26/67
D577,454 S *	9/2008	Maxik	D26/63
D614,801 S *	4/2010	Collins	D26/118
D715,475 S *	10/2014	Nankil	D26/85
D744,687 S *	12/2015	Li	D26/67

DESCRIPTION

FIG. 1 is a front perspective view of a red-light unit, showing my new design;

FIG. 2 is a top plan view thereof;

FIG. 3 is a bottom plan view thereof;

FIG. 4 is a right-side elevation view thereof;

FIG. 5 is a left side elevation view thereof;

FIG. 6 is a front elevation view thereof; and,

FIG. 7 is a rear elevation view thereof.

The broken lines showing of a partial electric cord in the figures forms no part of the claimed design.

1 Claim, 5 Drawing Sheets

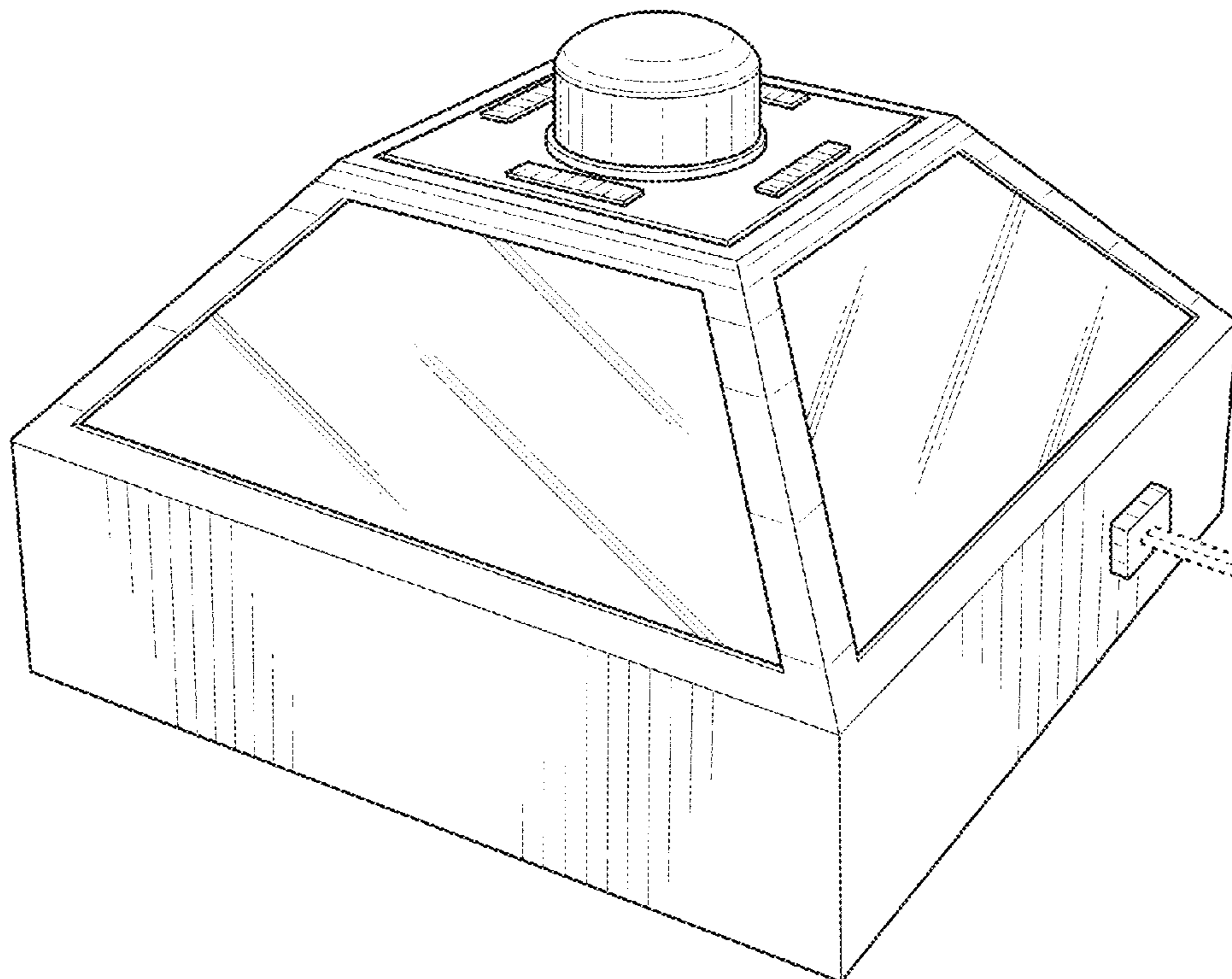

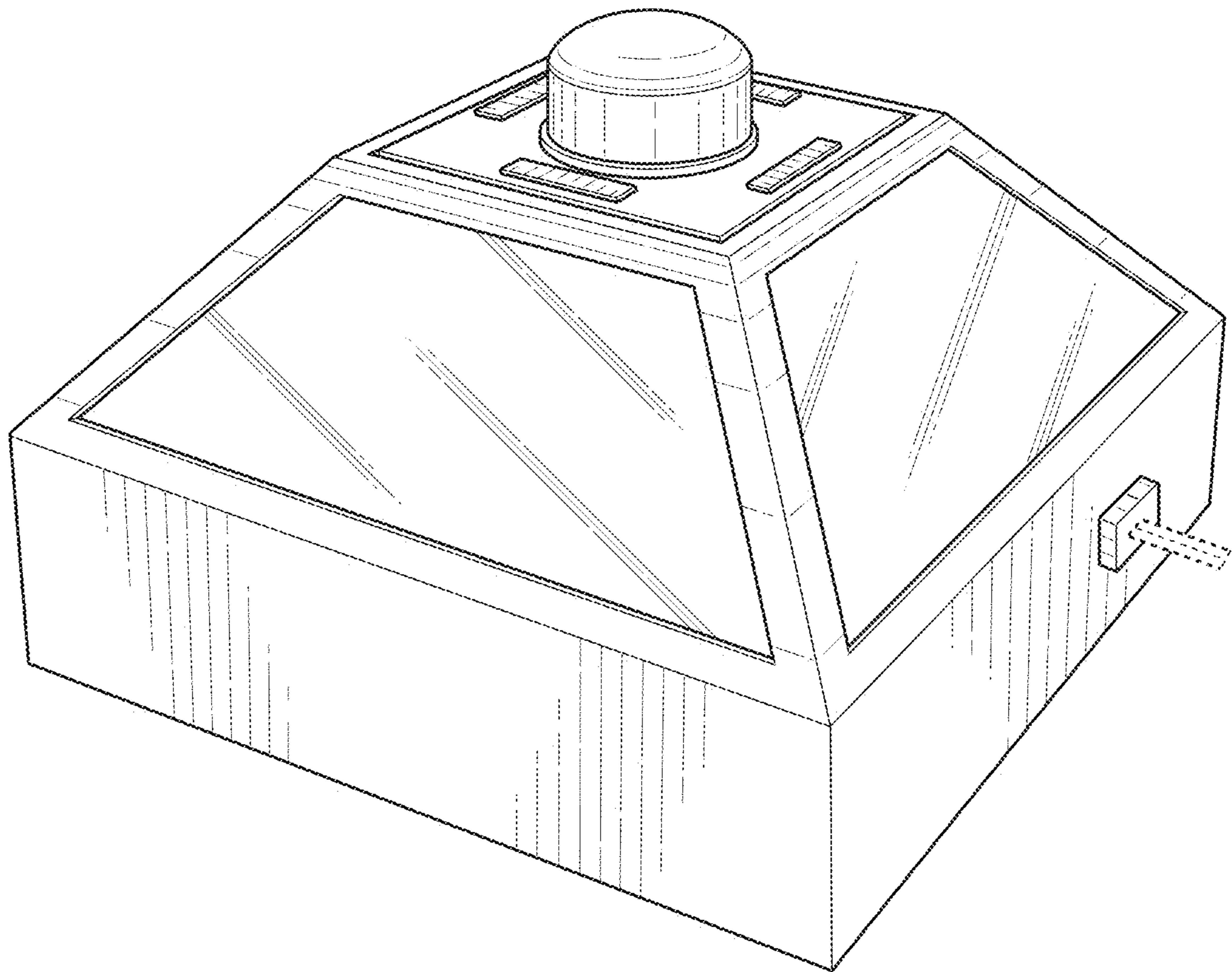

FIG. 1

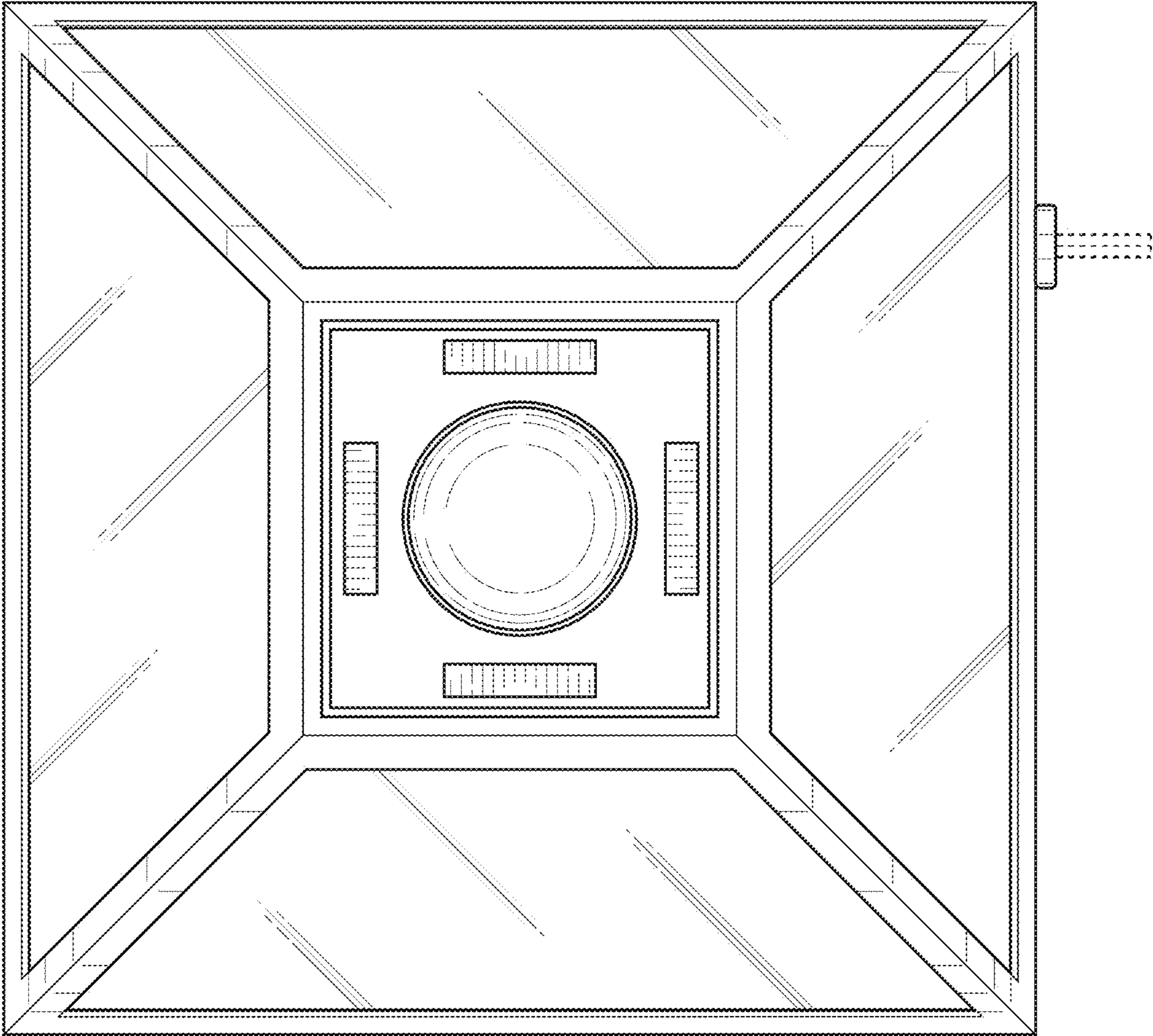

FIG. 2

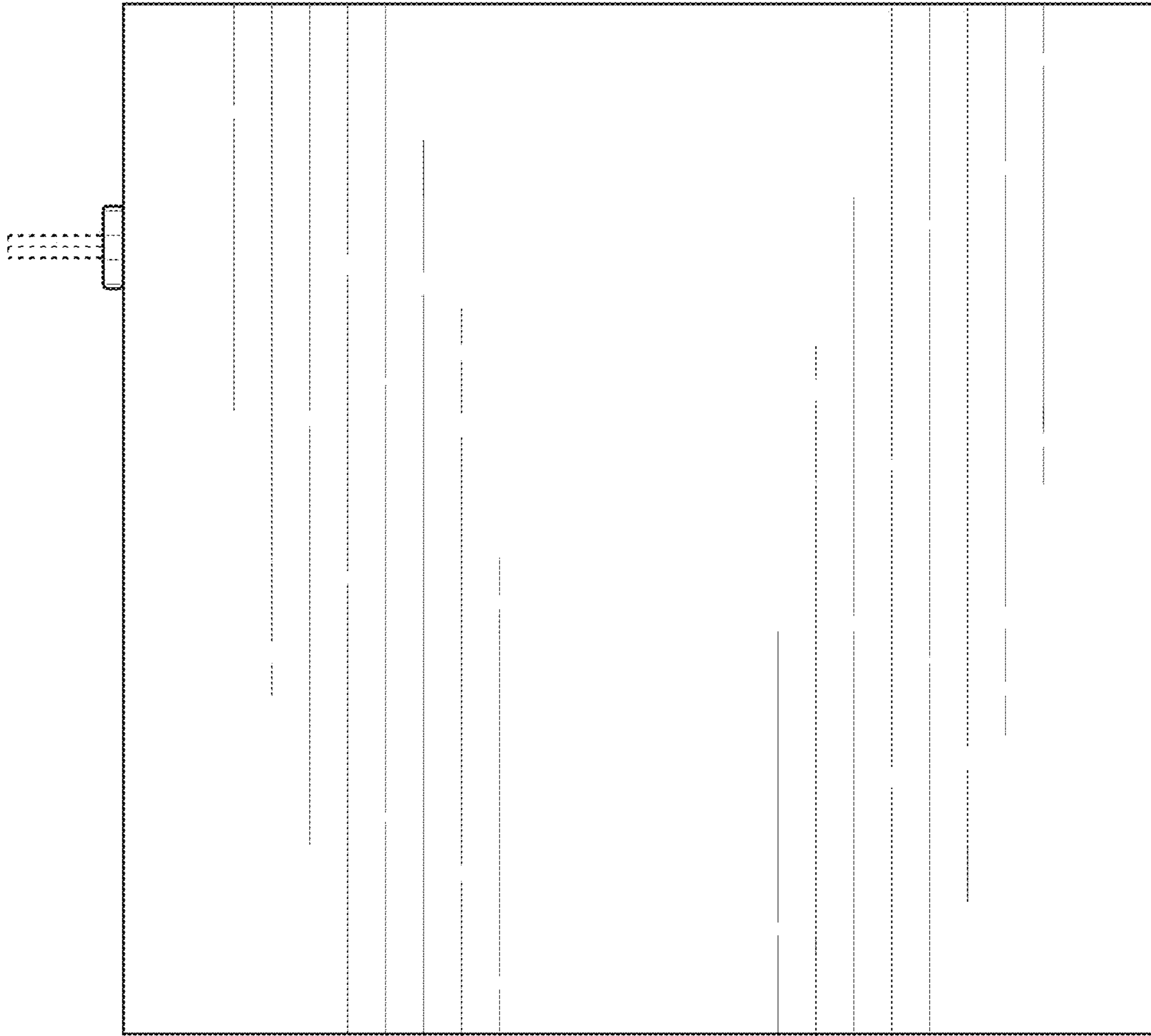

FIG. 3

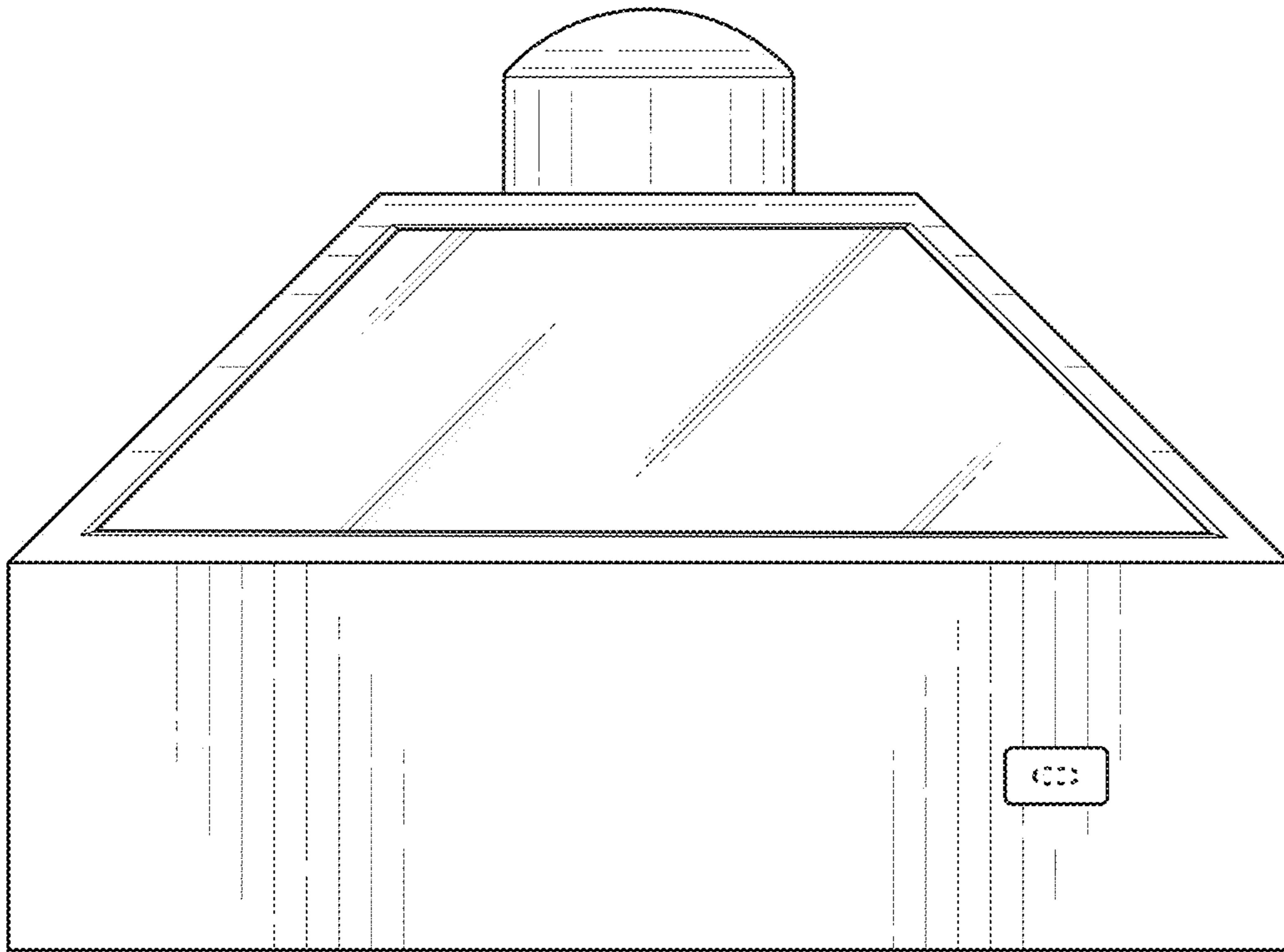

FIG. 4

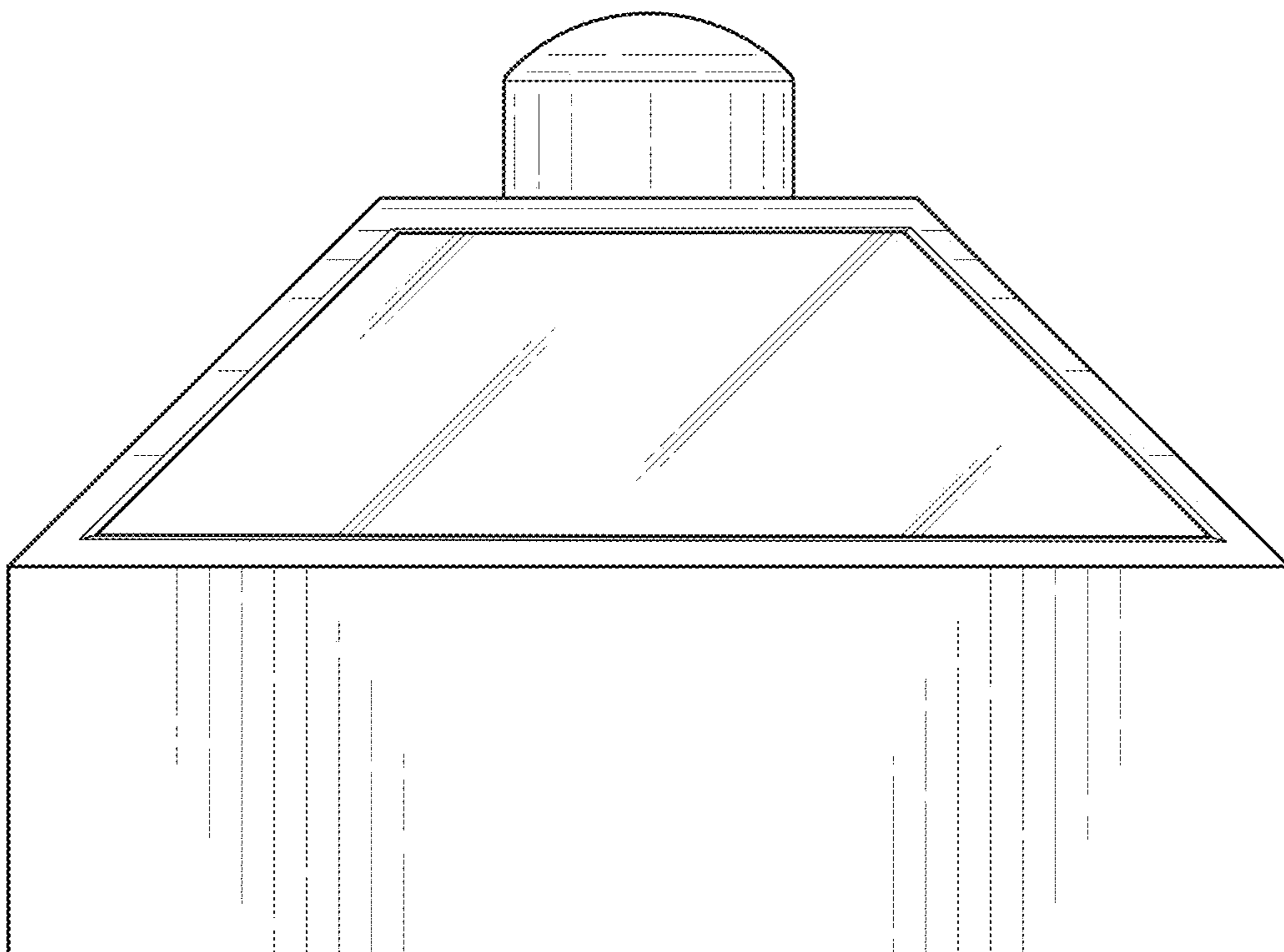

FIG. 5

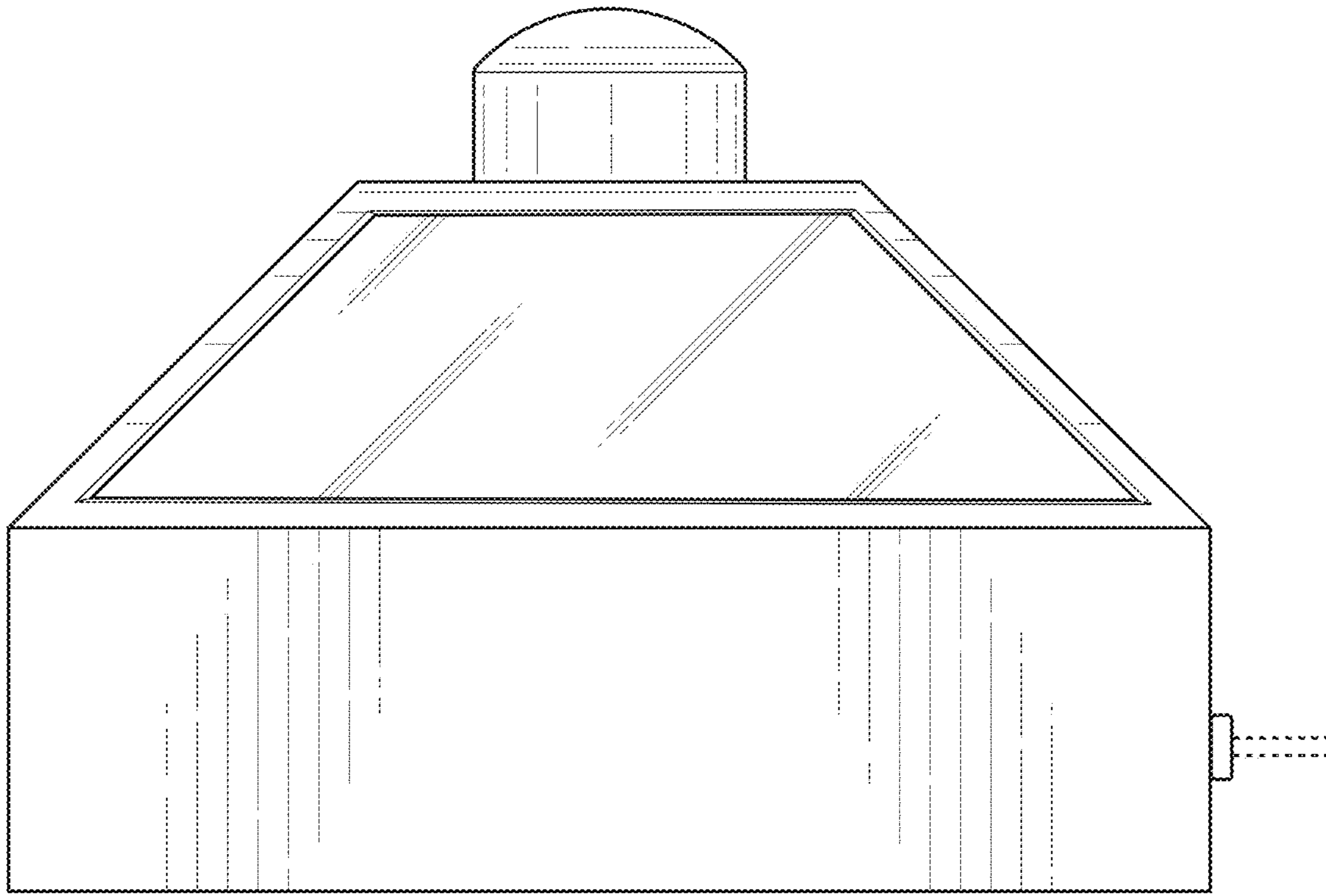

FIG. 6

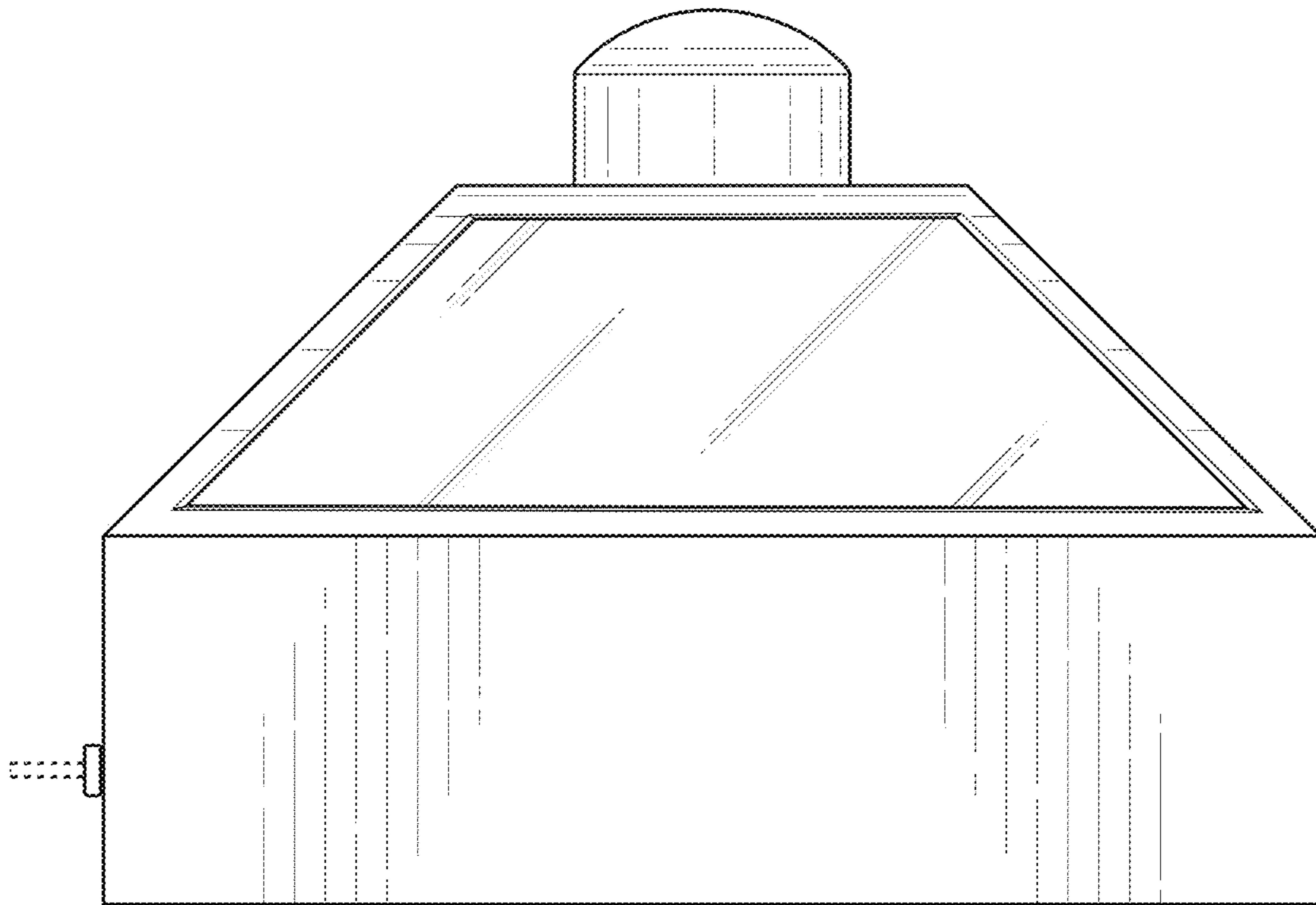

FIG. 7