



US00D985032S

(12) **United States Design Patent** (10) **Patent No.:** **US D985,032 S**
Riley (45) **Date of Patent:** **** May 2, 2023**

(54) **DUAL FLYWHEEL ENERGY APPARATUS**
(71) Applicant: **Graviton Motors, Inc.**, Snellville, GA (US)
(72) Inventor: **Brian R. Riley**, Snellville, GA (US)
(73) Assignee: **Graviton Motors, Inc.**, Snellville, GA (US)

D904,478 S * 12/2020 Costa F16H 35/10
D15/149
D931,350 S * 9/2021 Andersson D15/148
D947,297 S * 3/2022 Flick D21/667
2010/0272620 A1 * 10/2010 Greve A61L 2/07
29/428

(**) Term: **15 Years**
(21) Appl. No.: **29/772,304**

FOREIGN PATENT DOCUMENTS

FR 2868823 A1 * 10/2005 F16F 15/1343
FR 2894005 A1 * 6/2007 F16F 15/134
FR 3027986 A1 * 5/2016 F16F 15/1333
FR 3038024 A1 * 12/2016 F16F 15/13142
FR 3056045 B1 * 10/2019 G06K 19/0723
TW 200413637 A * 8/2004
WO WO-2006079258 A1 * 8/2006 F03G 1/00
WO WO-2017124208 A1 * 7/2017

(22) Filed: **Mar. 1, 2021**
(51) **LOC (14) Cl.** **15-99**
(52) **U.S. Cl.**
USPC **D15/148**
(58) **Field of Classification Search**
USPC D12/194; D13/158; D15/1-6, 14, 17,
D15/143, 148, 149; D23/23
CPC F02B 29/0475; F02M 35/161; F02M
35/1255; F02M 35/10137; F02M 35/048;
F16H 33/02
See application file for complete search history.

* cited by examiner

Primary Examiner — Patricia A Palasik
(74) *Attorney, Agent, or Firm* — Walter A. Rodgers

(57) **CLAIM**

The ornamental design for a dual flywheel energy apparatus, as shown and described.

(56) **References Cited**

DESCRIPTION

U.S. PATENT DOCUMENTS

5,894,763 A * 4/1999 Peters F16C 3/10
74/597
D420,689 S * 2/2000 Lannoch D15/148
D521,087 S * 5/2006 Francis D21/694
D555,742 S * 11/2007 Lai D21/694
D699,305 S * 2/2014 Rauwerdink D21/667
D808,452 S * 1/2018 Watrin D15/148
D846,012 S * 4/2019 Ishikawa D13/158
D867,414 S * 11/2019 Kawaguchi D13/174
D900,180 S * 10/2020 Pozzo D15/148
D900,181 S * 10/2020 Pozzo D15/148

FIG. 1 is a perspective view of a dual flywheel energy apparatus showing my new design;
FIG. 2 is a front elevation view thereof;
FIG. 3 is a rear elevation view thereof;
FIG. 4 is a left-side elevation view thereof;
FIG. 5 is a right-side elevation view thereof;
FIG. 6 is a top plan view thereof; and,
FIG. 7 is a bottom plan view thereof.

1 Claim, 7 Drawing Sheets

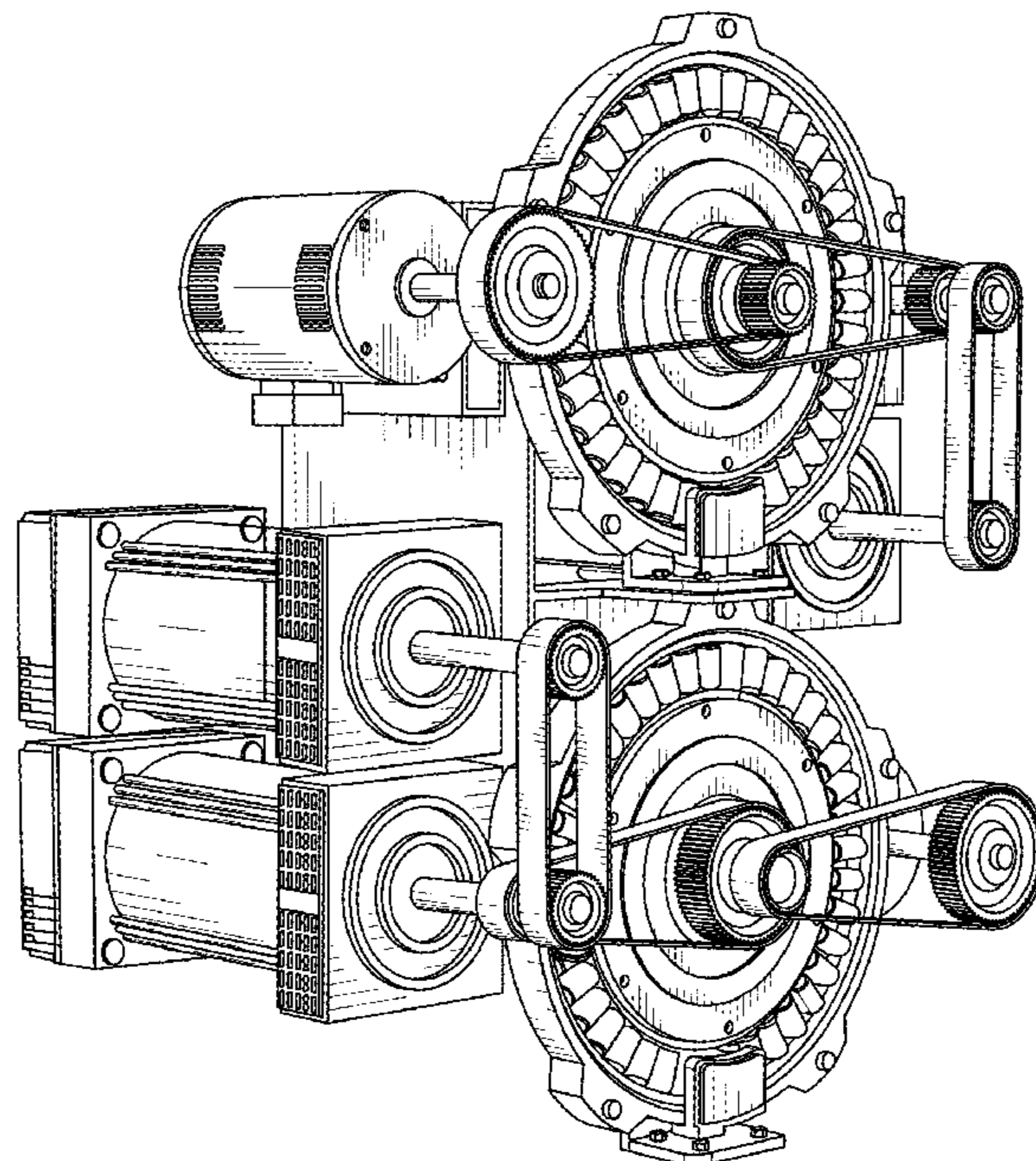

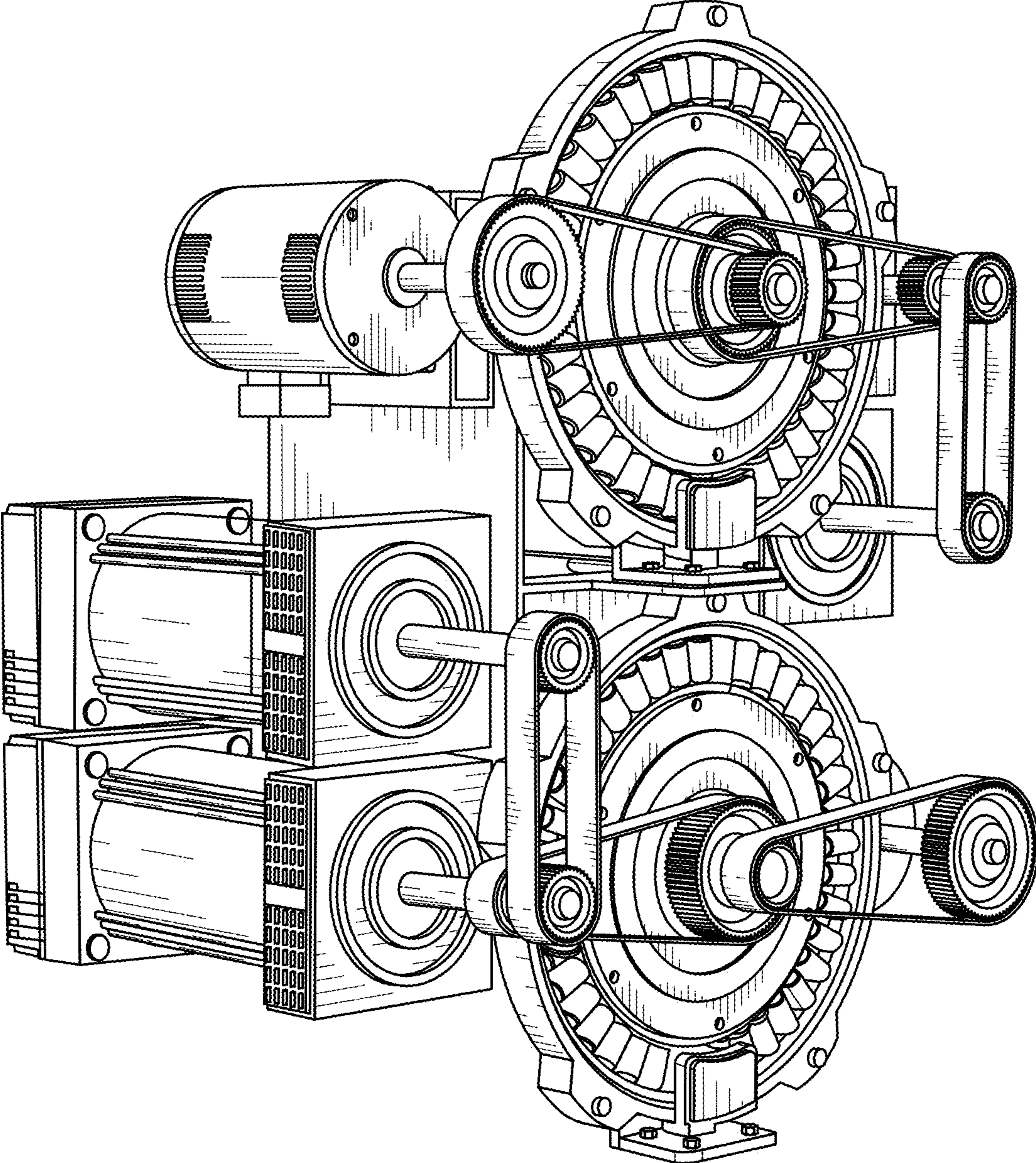

FIG. 1

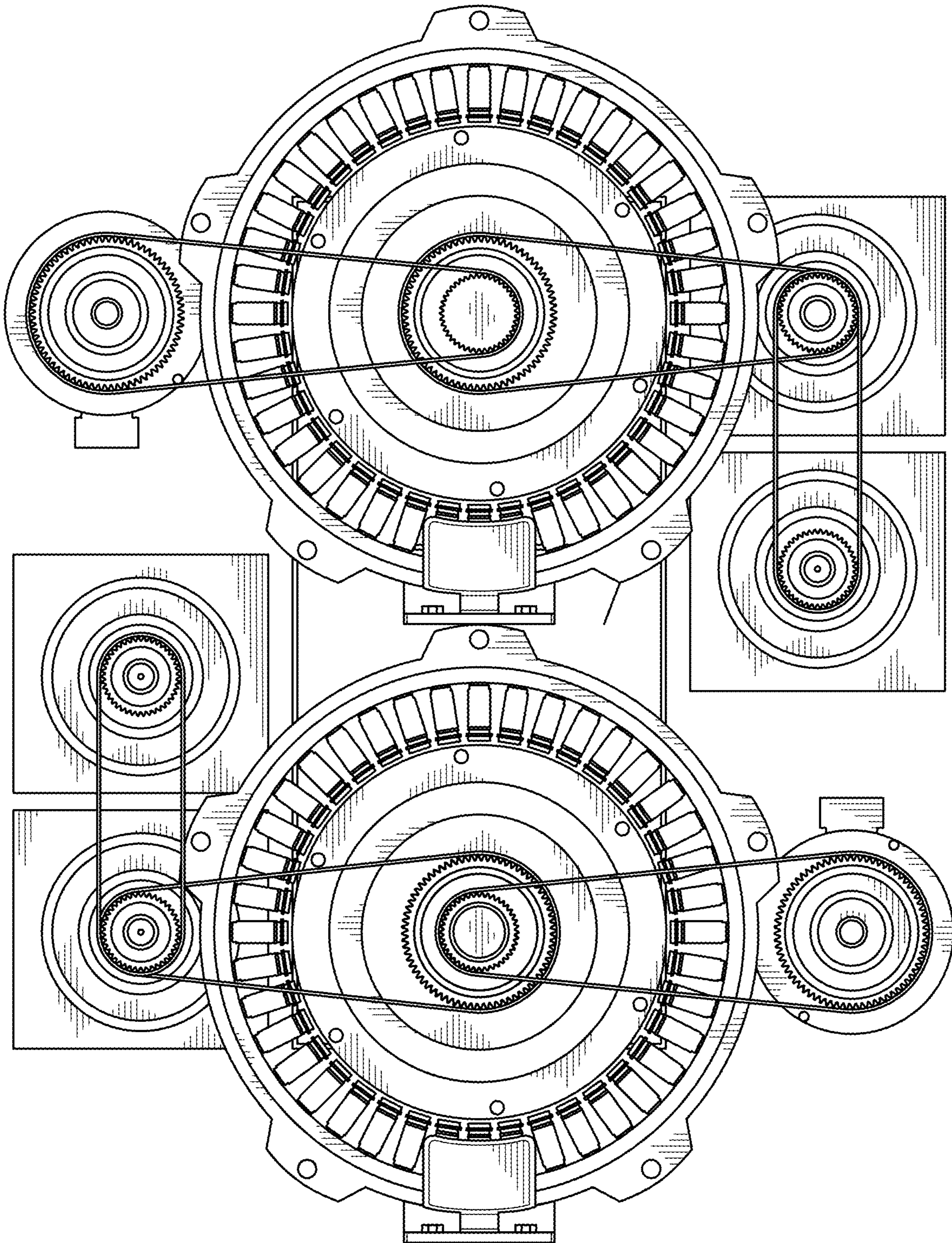

FIG. 2

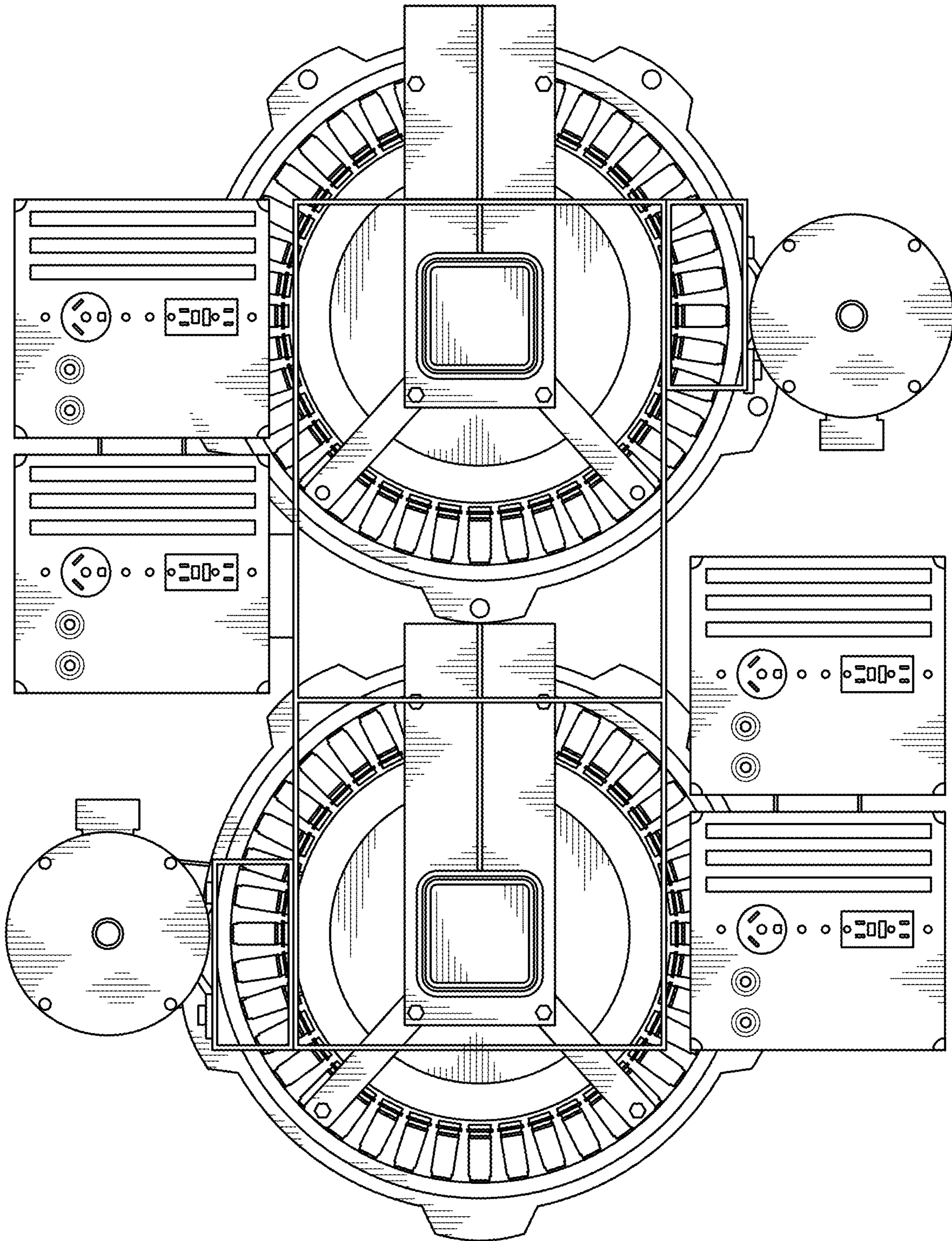

FIG. 3

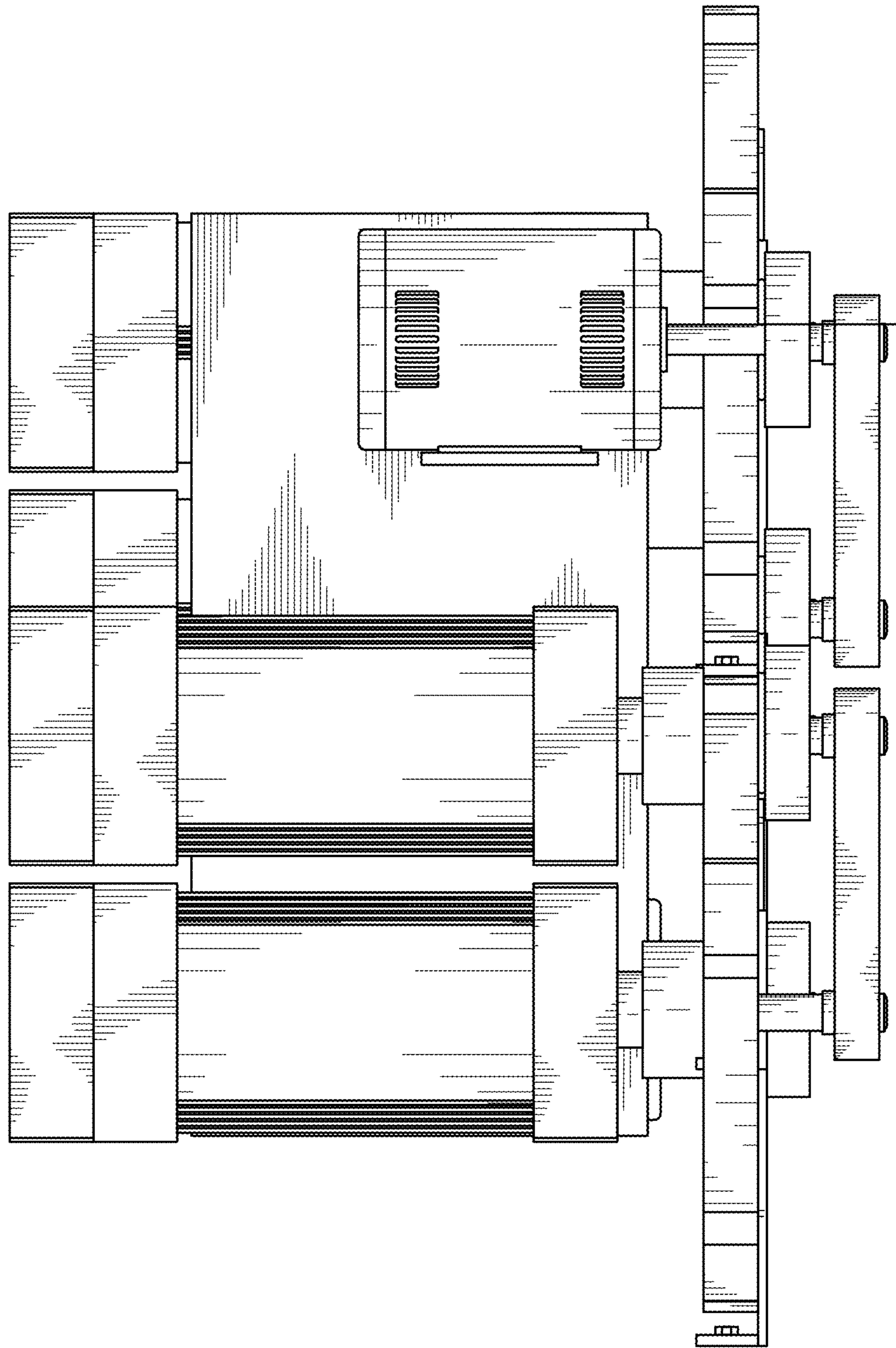

FIG. 4

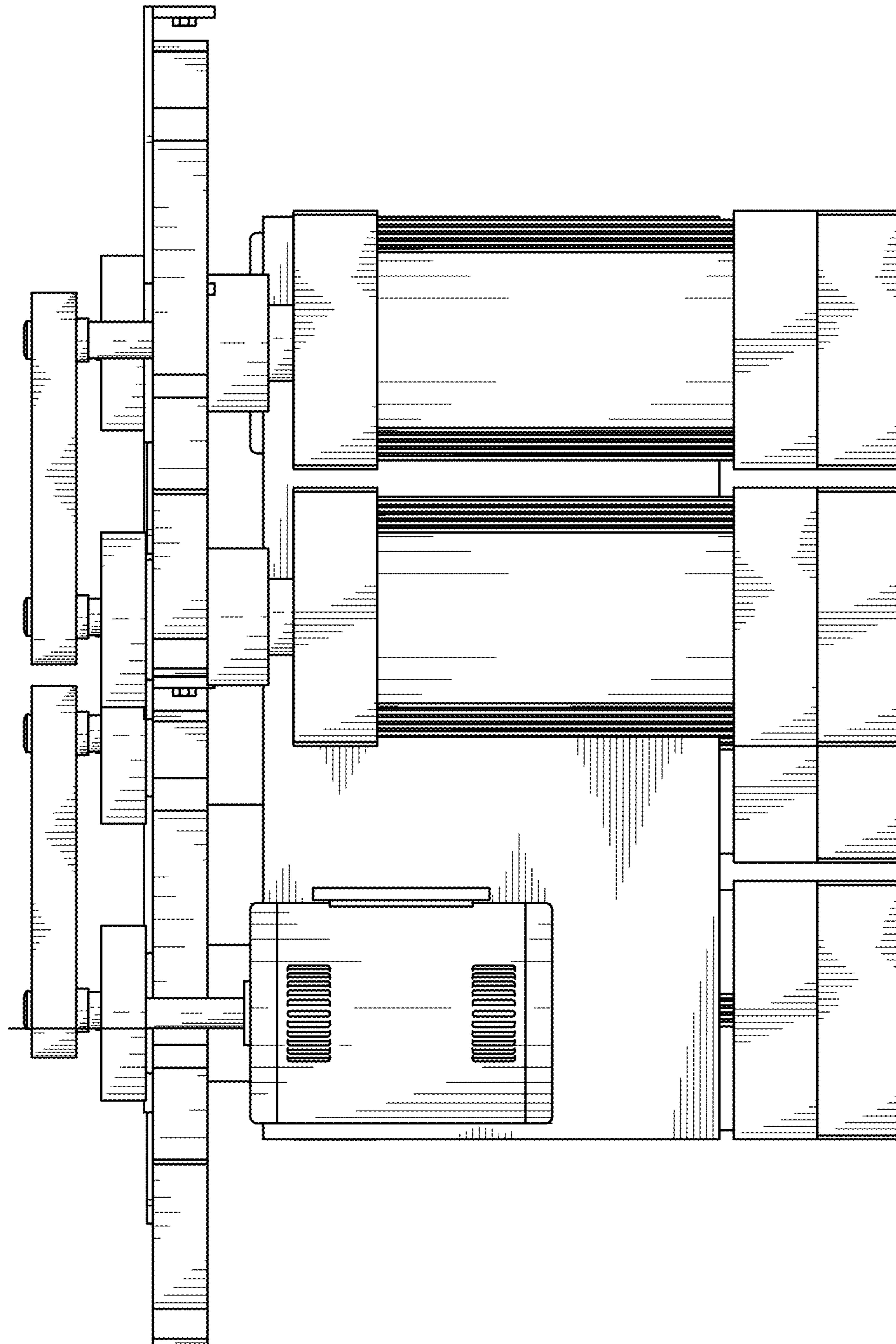

FIG. 5

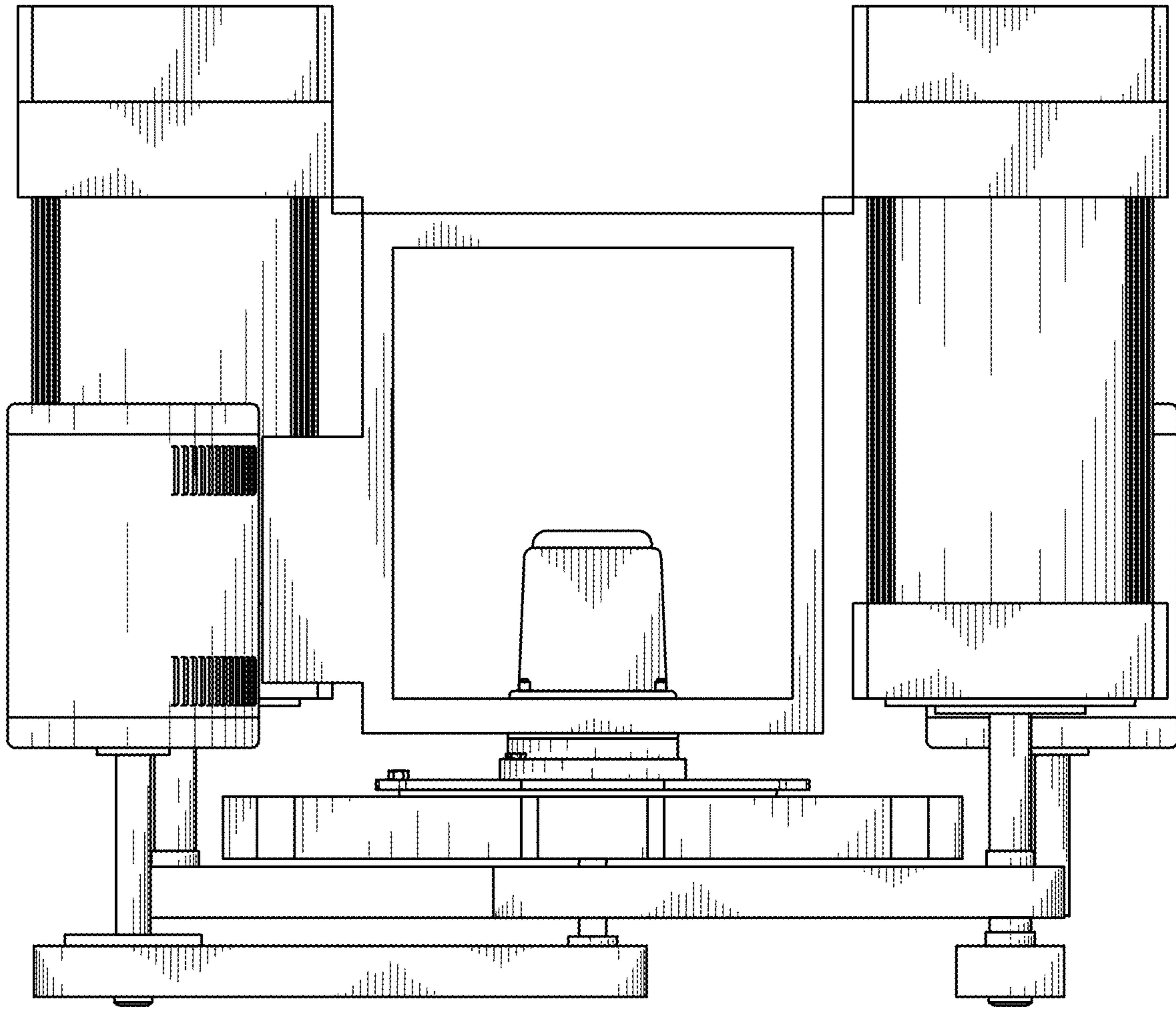

FIG. 6

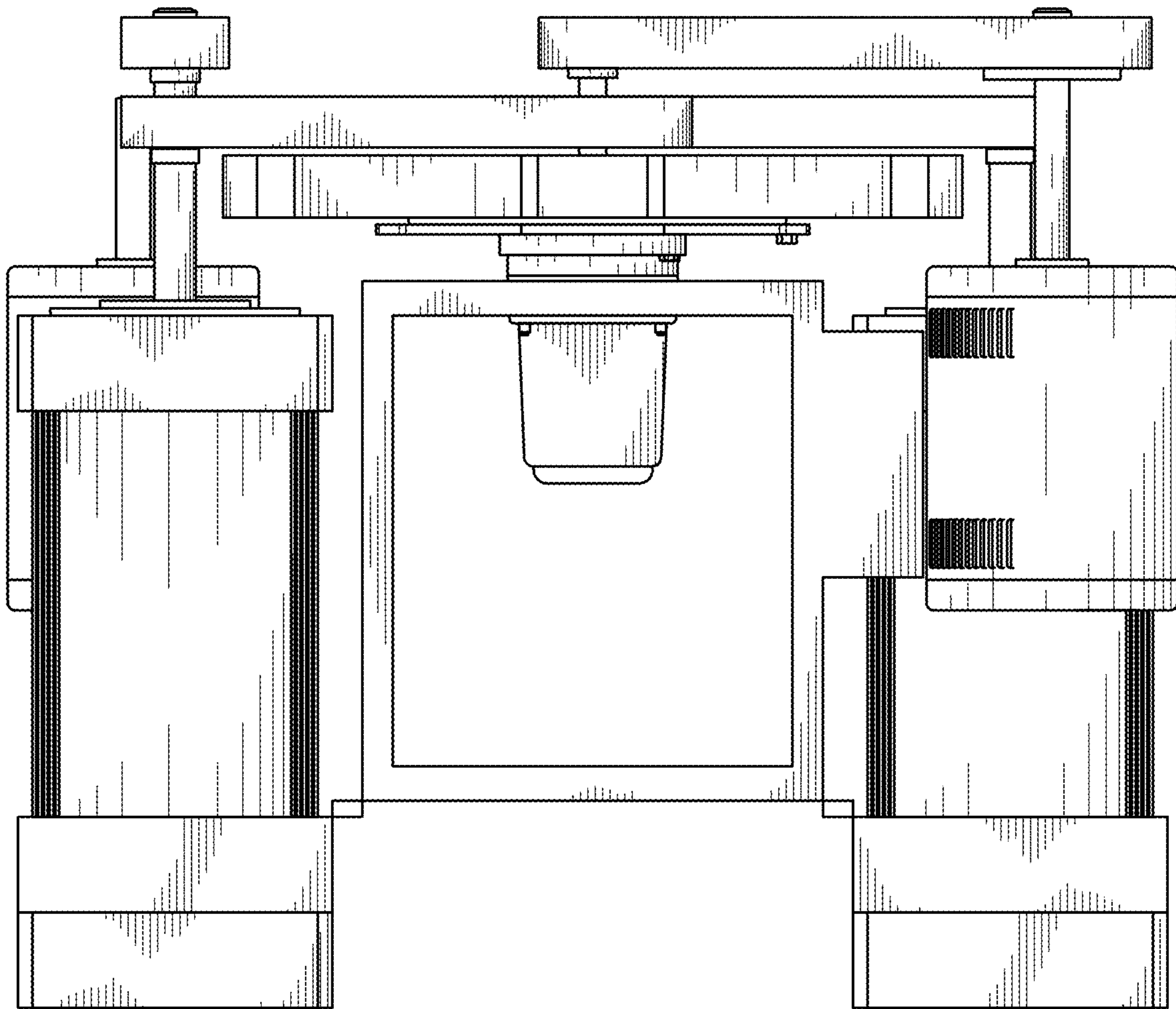

FIG. 7