



US00D985029S

(12) **United States Design Patent** (10) **Patent No.:** **US D985,029 S**
Cartwright (45) **Date of Patent:** **** May 2, 2023**

(54) **COLD-SWAGING DIE SET WITH TUBULAR SPLICE SLEEVE**

(71) Applicant: **Barsplice Products, Inc.**, Dayton, OH (US)

(72) Inventor: **Timothy L. Cartwright**, Tipp City, OH (US)

(73) Assignee: **Barsplice Products, Inc.**, Dayton, OH (US)

(**) Term: **15 Years**

(21) Appl. No.: **29/696,401**

(22) Filed: **Jun. 27, 2019**

(51) **LOC (14) Cl.** **15-09**

(52) **U.S. Cl.**
USPC **D15/123**

(58) **Field of Classification Search**
USPC D15/122, 128, 135, 136, 138, 140, 143
CPC B25B 27/146; B25B 27/10; H01R 43/042;
B21D 37/10

See application file for complete search history.

(56) **References Cited**

U.S. PATENT DOCUMENTS

D25,804 S *	7/1896	Zell	D15/138
1,966,593 A *	7/1934	O'Russa	H01R 43/042
				81/304
D154,028 S *	6/1949	DuMont	D15/138
3,098,517 A *	7/1963	Zimmerman, Jr.	..	H01R 43/058
				72/399
4,067,224 A *	1/1978	Birks	E04C 5/165
				29/517
4,192,171 A *	3/1980	Hamilton	H01R 43/042
				72/454
4,276,764 A *	7/1981	Kozhevnikov	B21J 5/02
				72/340
5,421,186 A *	6/1995	Lefavour	H01R 43/042
				72/409.14

(Continued)

OTHER PUBLICATIONS

BarSplice Products, Taper Threaded Grip-Twist Swaging and Assembly video demonstration, (uploaded Jun. 20, 2019), Youtube.com, URL:<<https://www.youtube.com/watch?v=UvryfzkFChc>> (Year: 2019).*

(Continued)

Primary Examiner — Calvin E Vansant

Assistant Examiner — Mark T. Philipps

(74) *Attorney, Agent, or Firm* — Jacox, Meckstroth & Jenkins

(57) **CLAIM**

The ornamental design of a cold-swaging die set with tubular splice sleeve, as shown and described.

DESCRIPTION

FIG. 1 is a perspective view of a cold-swaging die set with tubular splice sleeve in accordance with my invention and is shared by all embodiments;

FIG. 2 is an end view thereof and is shared by all embodiments;

FIG. 3 is a side view of a first embodiment thereof;

FIG. 4 is a side view with the die side removed for ease of illustration with the view being directed along line 4-4 on FIG. 2 thereof;

FIG. 5 is a side view of a second embodiment thereof; and, FIG. 6 is a side view with the die side removed for ease of illustration with the view being directed along line 6-6 on FIG. 2 thereof.

The broken lines in FIGS. 1-6 illustrate a polymer rebar and form no part of the claimed invention.

The radially compressed tubular sleeves shown in the FIGS. 1-6 have diametrically opposed longitudinally extending ridges formed by the die set.

1 Claim, 3 Drawing Sheets

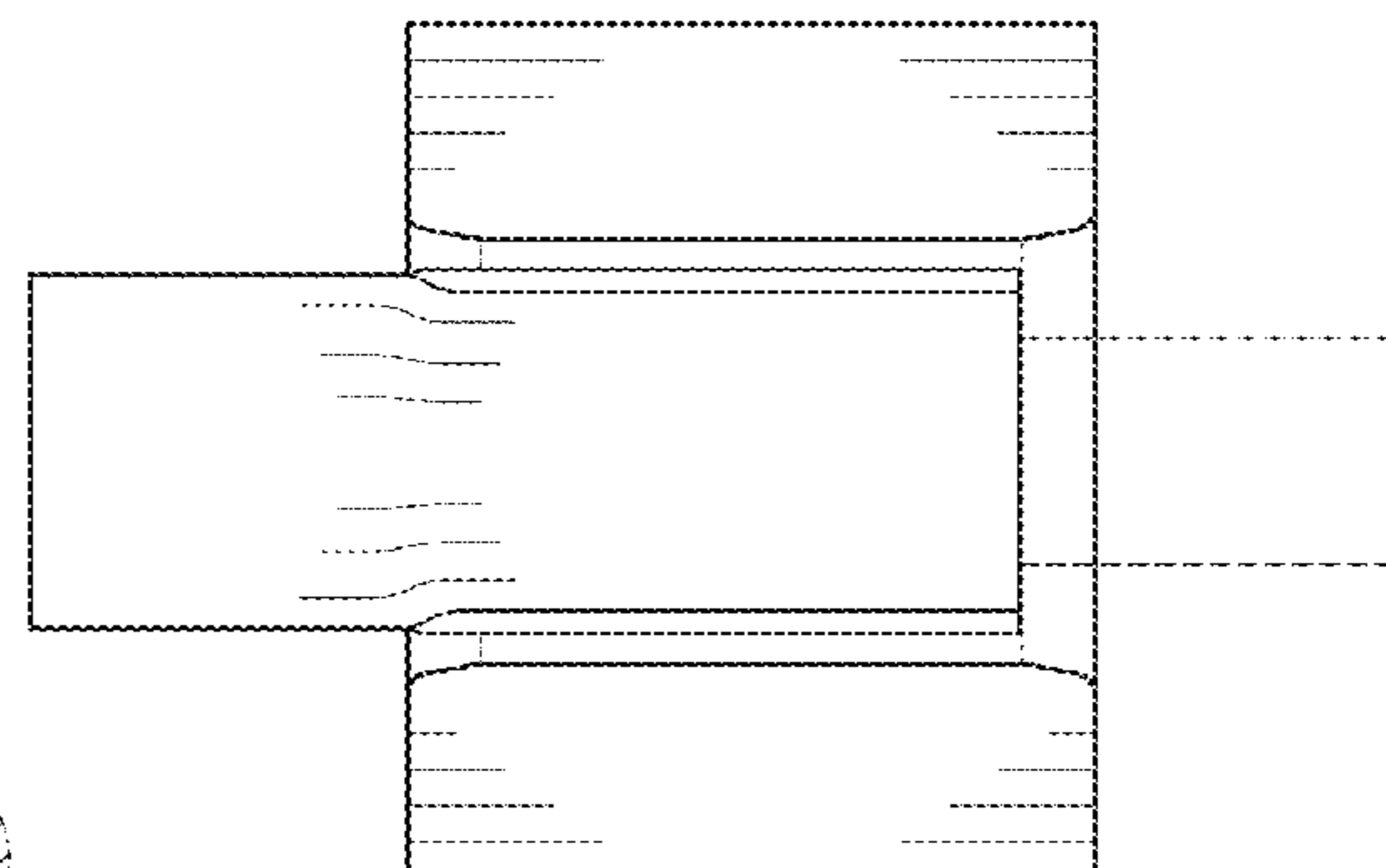
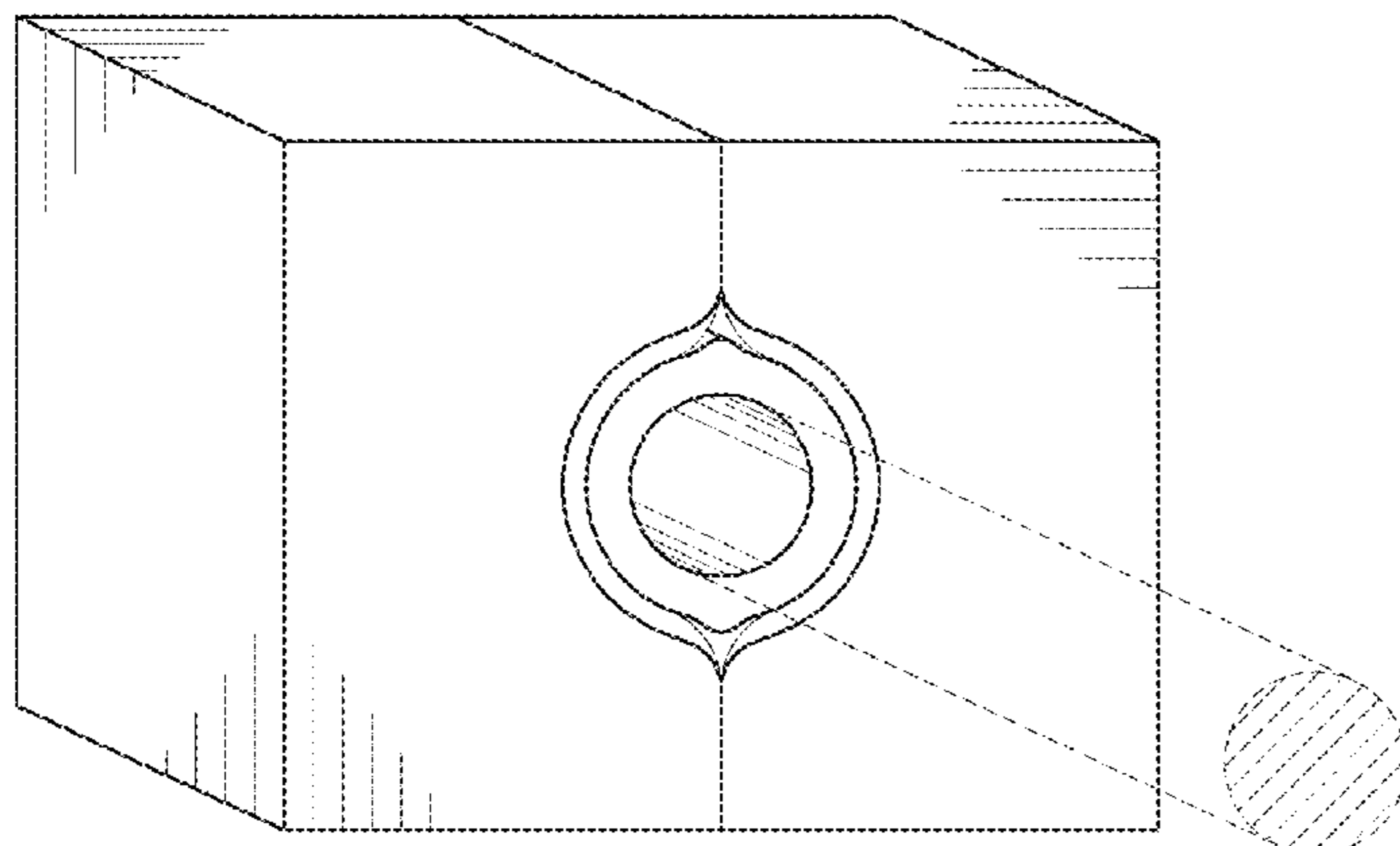

(56)

References Cited

U.S. PATENT DOCUMENTS

5,879,503 A * 3/1999 McDunn B29C 66/9141
219/535
6,571,452 B1 6/2003 Wang
7,032,286 B2 4/2006 Wang
7,490,504 B1 * 2/2009 Hirsch B25B 27/146
72/409.19
7,762,117 B2 * 7/2010 Faucher B25B 27/10
403/14
7,882,879 B2 * 2/2011 Patterson B29C 66/961
156/583.8
8,413,396 B2 4/2013 Oliva et al.
8,826,627 B2 9/2014 Hongo et al.
8,925,279 B2 1/2015 Pantelides et al.
9,404,254 B2 8/2016 Reigstad
D813,023 S 3/2018 Reigstad
10,243,313 B2 * 3/2019 Dinh H01R 43/058

D921,721 S * 6/2021 Matzen B21G 3/28
D15/136
2010/0287765 A1 * 11/2010 Stephens H01R 43/0421
29/751
2014/0144011 A1 * 5/2014 Sugimoto H01R 43/058
29/863
2015/0222072 A1 * 8/2015 Therrien B21D 37/10
72/414
2016/0174592 A1 * 6/2016 Baumeister A23G 3/0268
425/117
2017/0201056 A1 * 7/2017 Malloy H01R 43/058
2018/0019561 A1 * 1/2018 Montminy B21D 37/14

OTHER PUBLICATIONS

BarSplice Products, Engineered mechanical splice systems technical page, (site visited Jun. 14, 2022), BarSplice website, URL:<<https://www.barsplice.com/technical-information.html>> (Year: 2022).*

* cited by examiner

FIG. 1

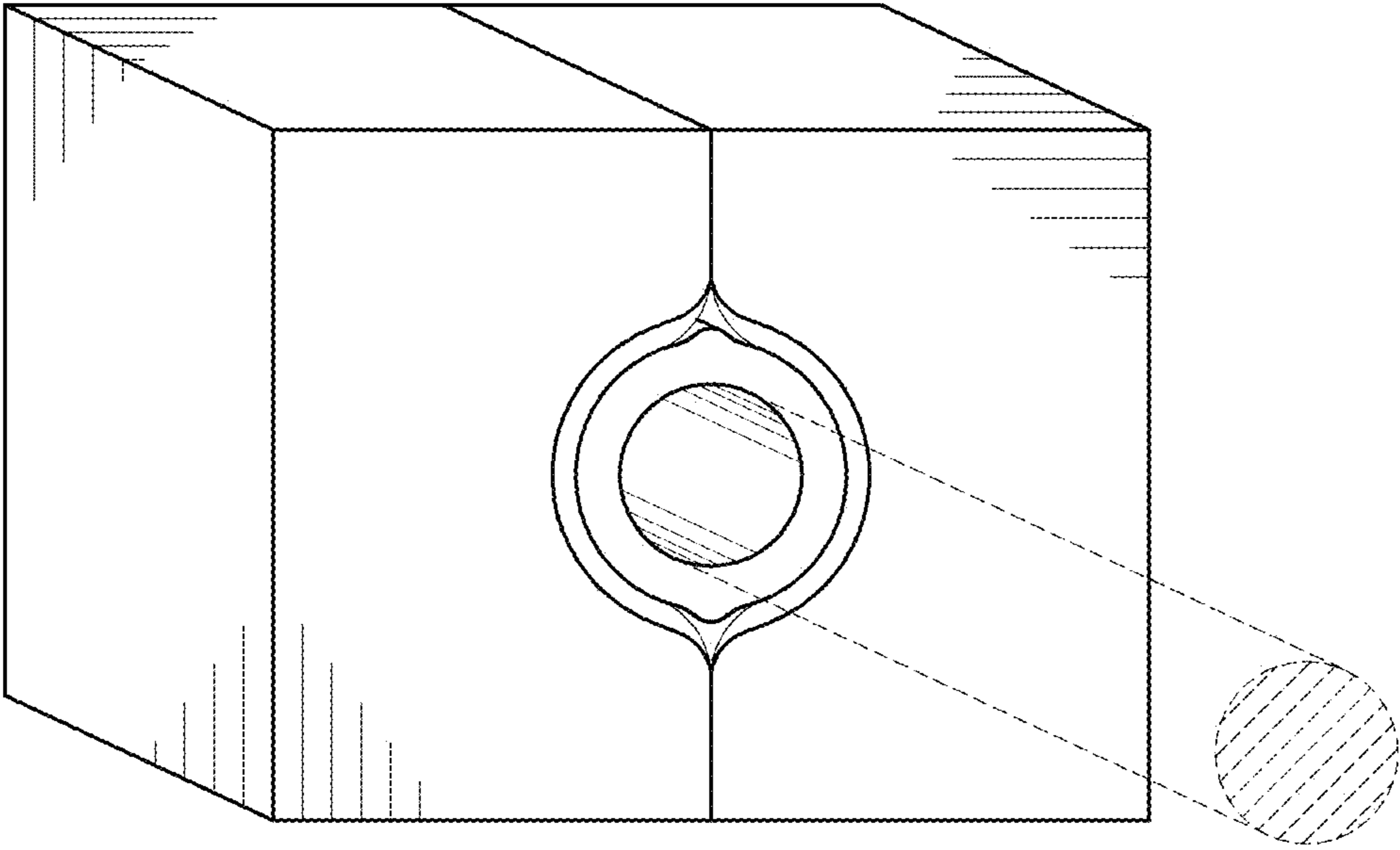

FIG. 2

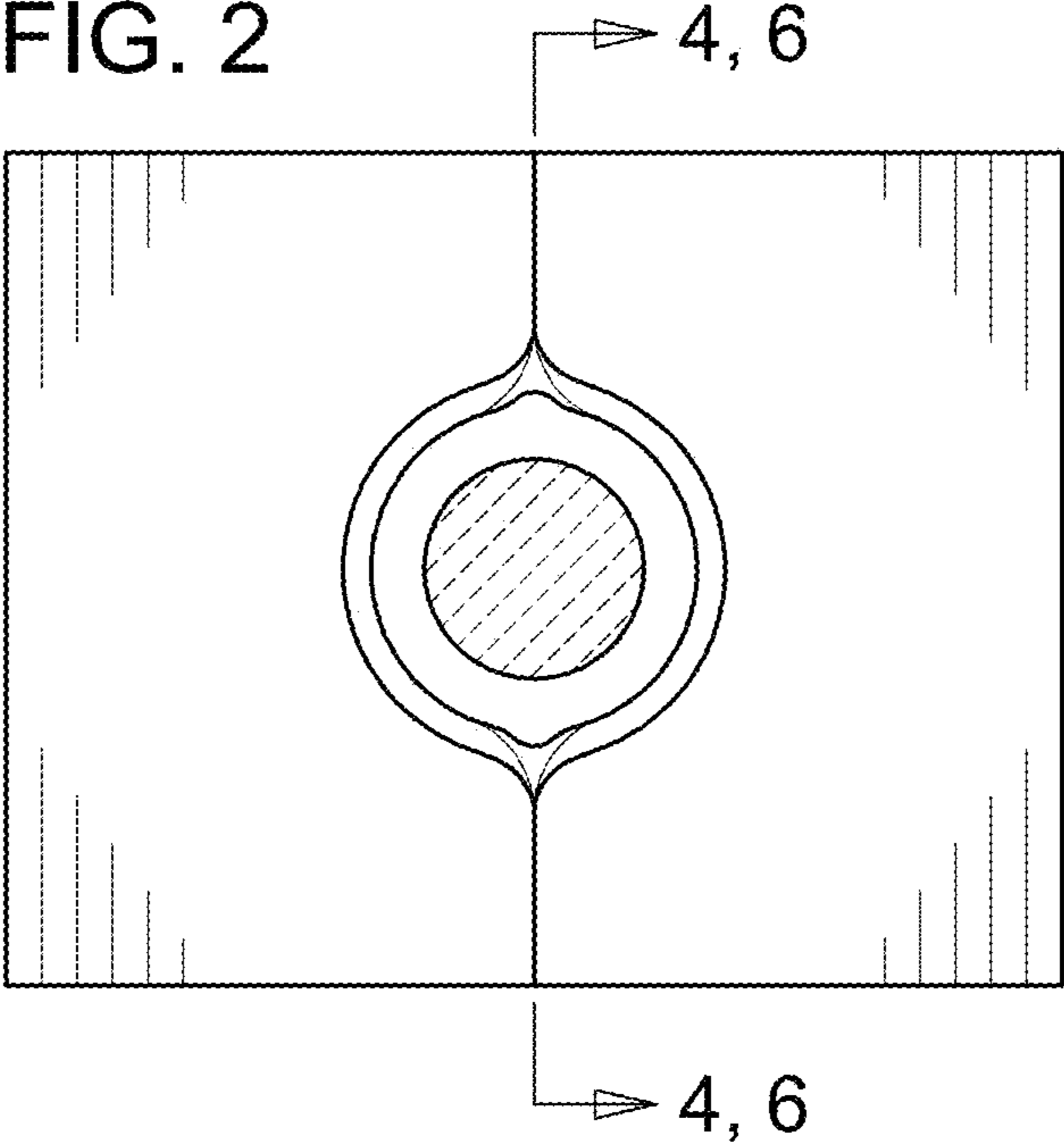

FIG. 3

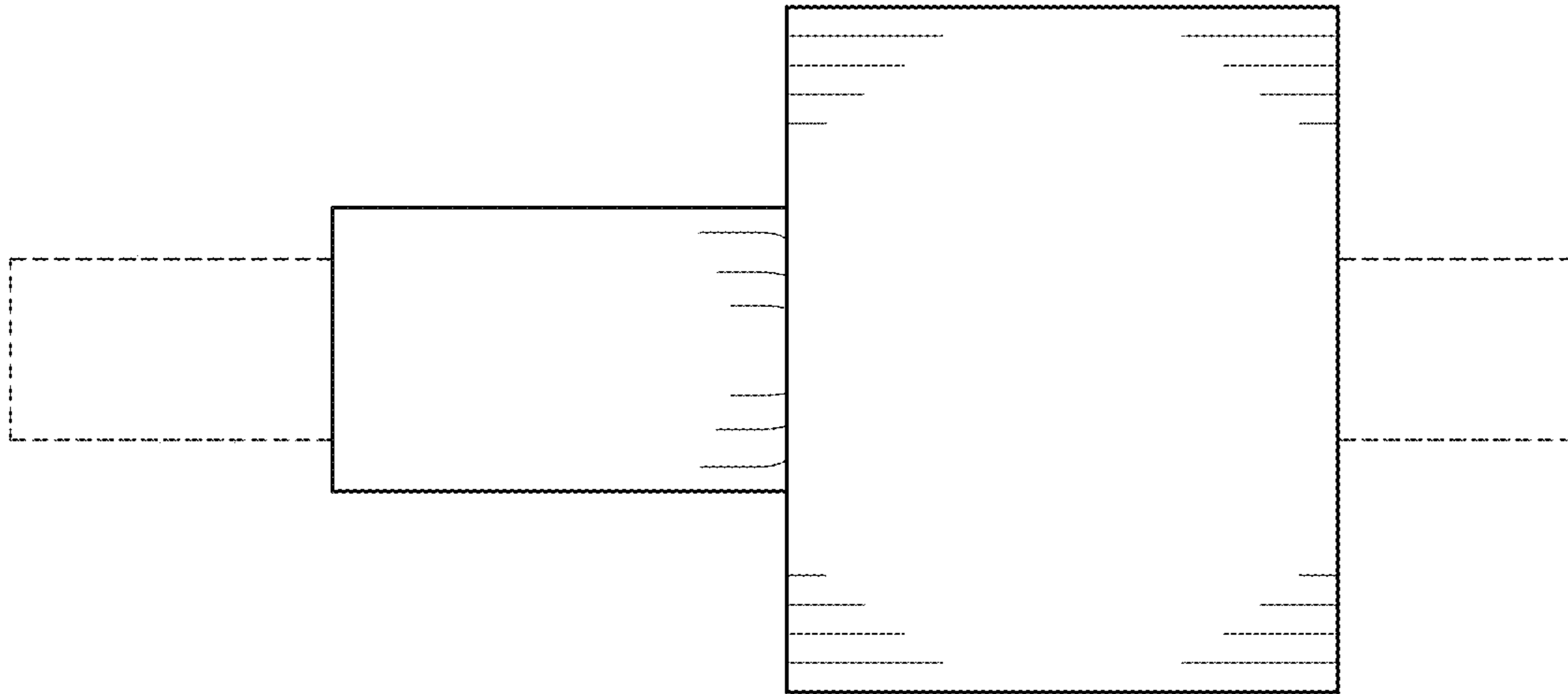

FIG. 4

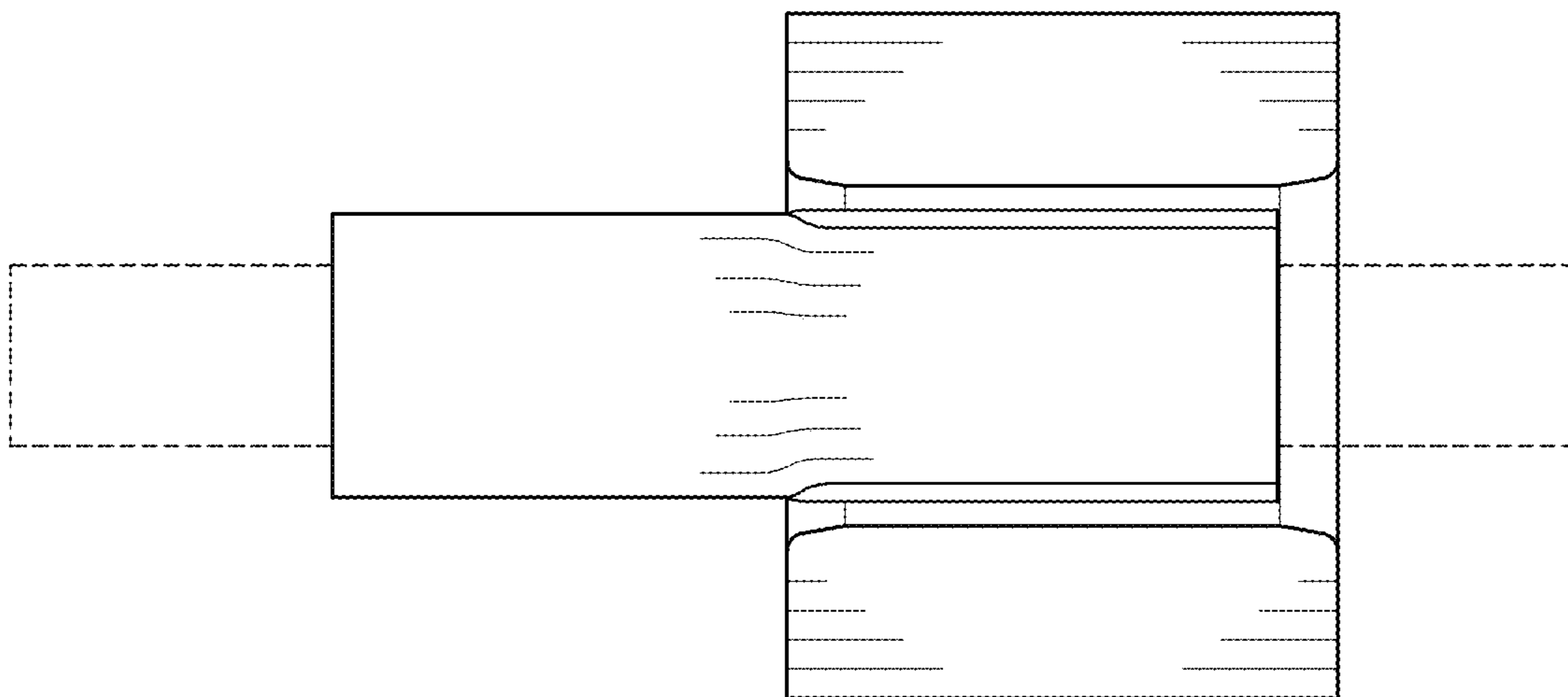

FIG. 5

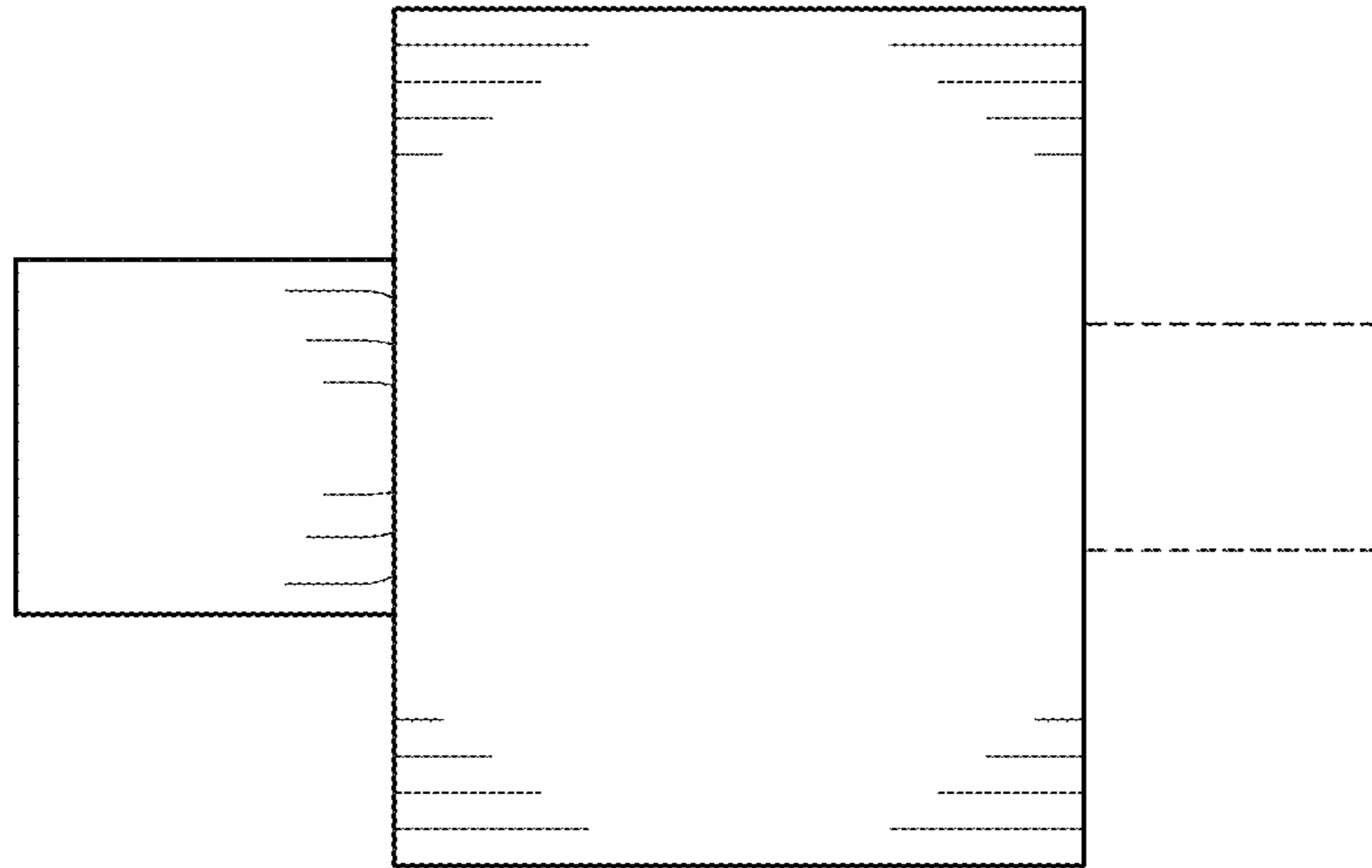

FIG. 6

