



US00D984900S

(12) **United States Design Patent** (10) **Patent No.:** **US D984,900 S**  
**Probst** (45) **Date of Patent:** **\*\* \*May 2, 2023**

- (54) **BOTTLES FOR COSMETICS** 5,252,312 A \* 10/1993 Gentile ..... A61K 8/22  
424/44
- (71) Applicant: **BIRKENSTOCK IP GMBH**, Linz am Rhein (DE) D459,211 S \* 6/2002 McGuinness ..... D9/689  
D499,338 S \* 12/2004 Mulder ..... D9/558  
D554,505 S \* 11/2007 Gilbert ..... D9/503  
D563,238 S \* 3/2008 Nevins ..... D9/684  
D570,690 S \* 6/2008 McGuinness ..... D9/686  
D582,278 S \* 12/2008 Bourne ..... D9/504  
D592,524 S \* 5/2009 Padain ..... D9/691  
D610,910 S \* 3/2010 Simmons ..... D9/503  
D619,460 S \* 7/2010 Beckerman ..... D9/500  
D620,742 S \* 8/2010 Lion ..... D9/504  
D628,885 S \* 12/2010 Hale ..... D9/449  
8,690,022 B2 \* 4/2014 Lee ..... B05B 11/0029  
222/536
- (72) Inventor: **Esther Probst**, Hohenschäftlarn (DE)
- (73) Assignee: **BIRKENSTOCK IP GMBH**, Linz am Rhein (DE)
- (\* ) Notice: This patent is subject to a terminal disclaimer.
- (\*\* ) Term: **15 Years** D708,956 S \* 7/2014 McKay ..... D9/449  
D719,448 S \* 12/2014 Pires ..... D9/504  
D720,993 S \* 1/2015 Marotti ..... D9/571
- (21) Appl. No.: **29/798,692**
- (22) Filed: **Jul. 9, 2021**

**Related U.S. Application Data**

- (60) Division of application No. 29/676,436, filed on Jan. 10, 2019, now Pat. No. Des. 924,693, which is a continuation of application No. 35/502,807, filed on Feb. 13, 2017 (U.S. filing date under 35 U.S.C. 384), and having an international filing date of Feb. 13, 2017, now Pat. No. Des. 854,939.

- (51) **LOC (14) Cl.** ..... **09-01**
- (52) **U.S. Cl.**  
USPC ..... **D9/688**
- (58) **Field of Classification Search**  
USPC ..... D9/542, 504, 688, 558, 503, 571, 449,  
D9/500, 686, 684, 545, 727; D7/532;  
D28/89; D10/104.1  
CPC ..... A61K 8/22  
See application file for complete search history.

(56) **References Cited**

**U.S. PATENT DOCUMENTS**

- D78,465 S \* 5/1929 Groniger ..... D9/500
- D180,820 S \* 8/1957 DuPree ..... D9/545

(Continued)

*Primary Examiner* — Rhea Shields

(74) *Attorney, Agent, or Firm* — Fross, Zelnick, Lehrman & Zissu PC; Charles T. J. Weigeil, Esq.

(57) **CLAIM**

The ornamental design for a bottle for cosmetics, as shown and described.

**DESCRIPTION**

The patent or application file contains at least one drawing executed in color. Copies of this patent or patent application publication with color drawing(s) will be provided by the Office upon request and payment of the necessary fee.

FIG. 1 is a front view showing my design;  
FIG. 2 is a top view thereof;  
FIG. 3 is a front view of an alternative embodiment of my design; and,  
FIG. 4 is a top view thereof.  
The broken lines in the drawings illustrate environmental matter that forms no part of the claimed design.

**1 Claim, 2 Drawing Sheets**  
**(2 of 2 Drawing Sheet(s) Filed in Color)**



(56)

**References Cited**

U.S. PATENT DOCUMENTS

D757,551 S *	5/2016	Pires .....	D9/503
D758,865 S *	6/2016	Pires .....	D9/503
D782,912 S *	4/2017	Jeong .....	D9/558
D809,399 S *	2/2018	Kwon .....	D9/542
D829,054 S *	9/2018	Breit .....	D7/510
D854,939 S *	7/2019	Probst .....	D9/688
D856,805 S *	8/2019	Moretti .....	D9/500
D881,013 S *	4/2020	Luu .....	D9/500
D924,693 S *	7/2021	Probst .....	D9/688
D939,350 S *	12/2021	Burns .....	D9/520
2008/0296247 A1 *	12/2008	Ribadeneira Mejia .....	
		B65D 47/0804	
		215/316	

\* cited by examiner

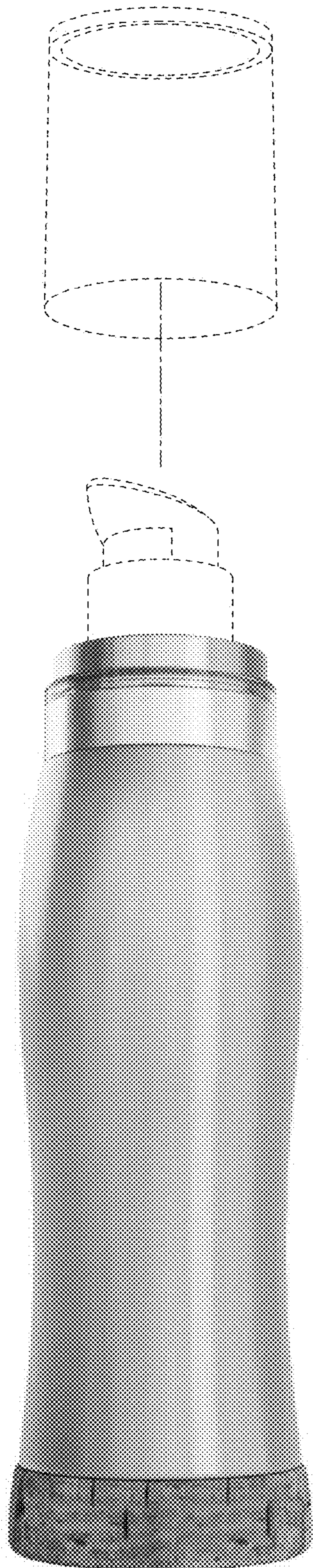

**Fig. 1**

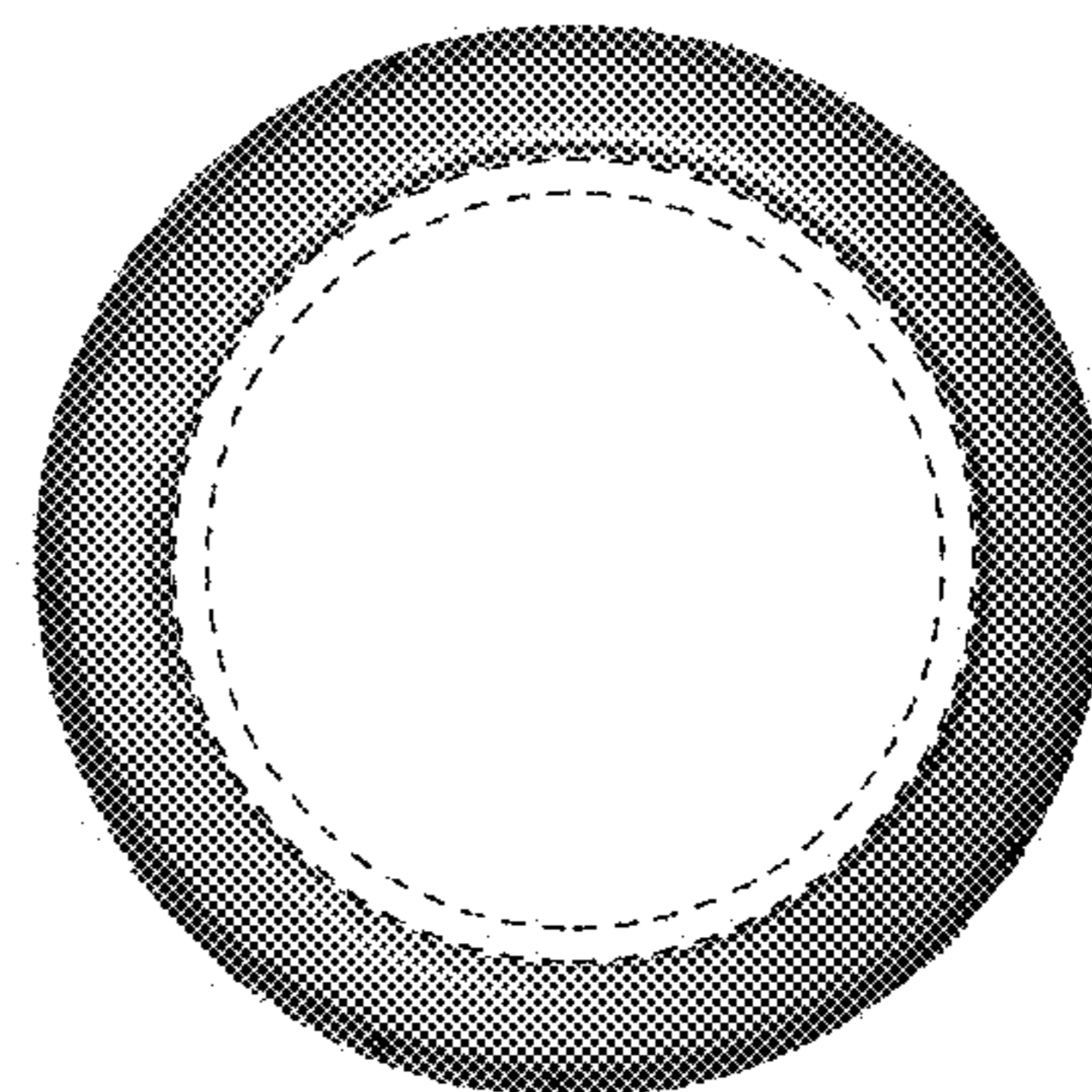

**Fig. 2**

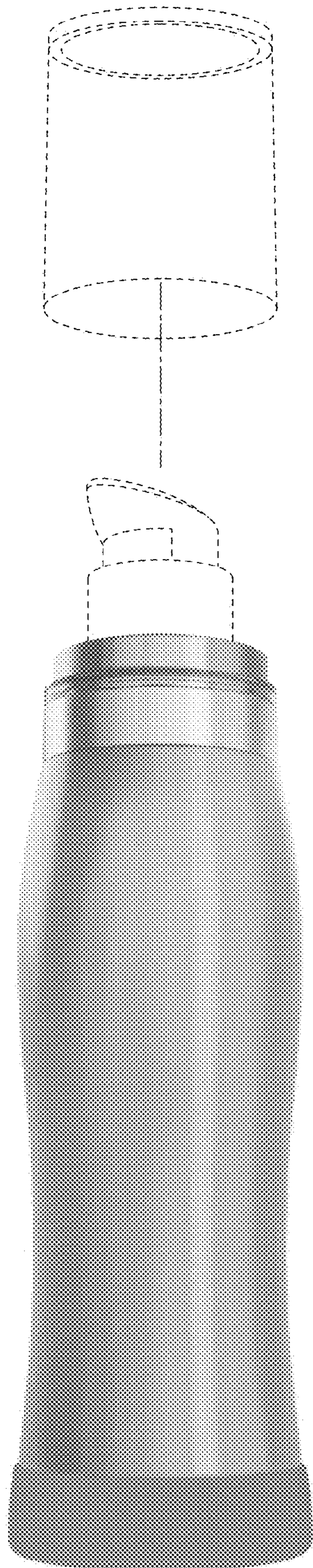

**Fig. 3**

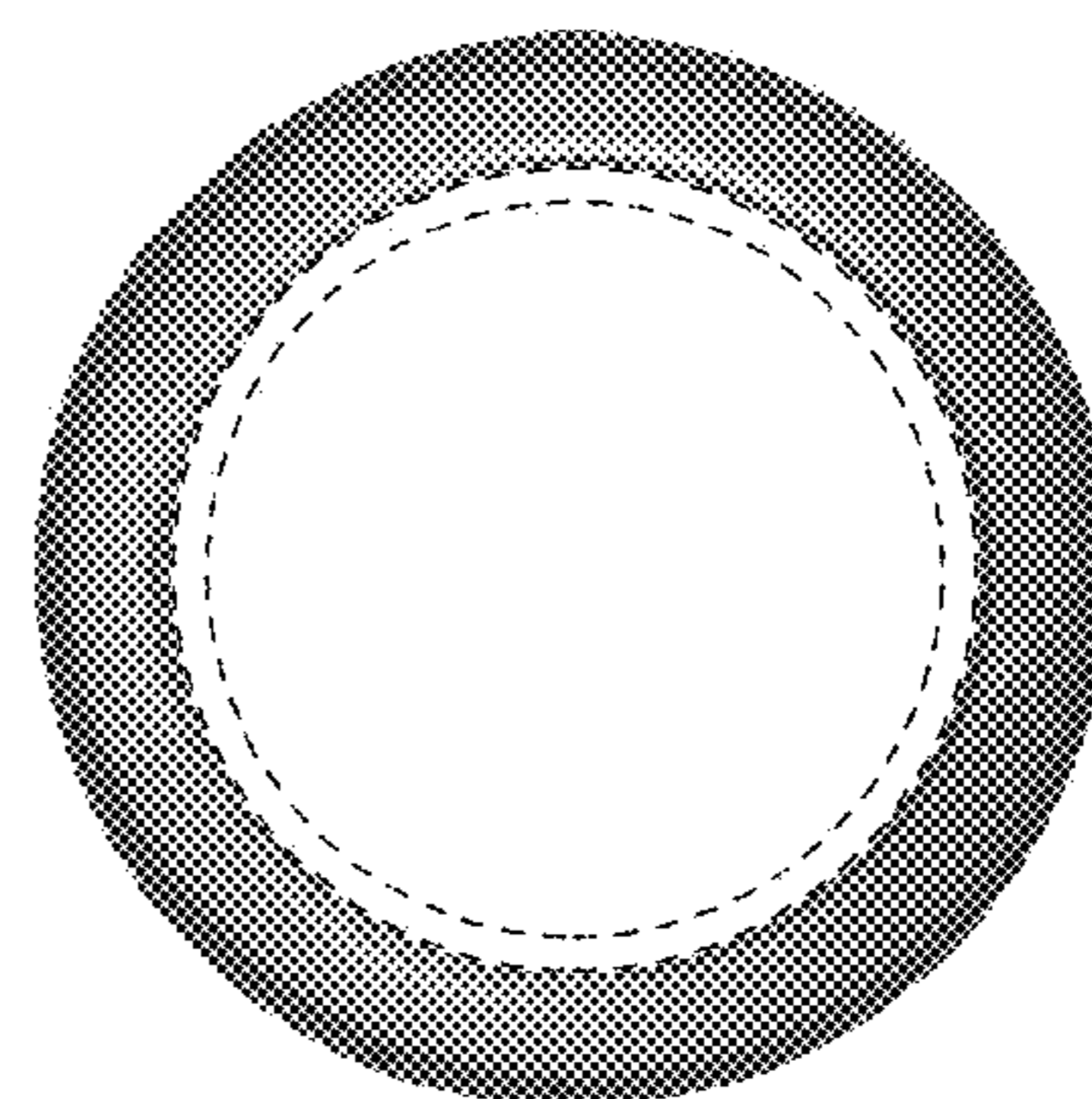

**Fig. 4**