



US00D984671S

(12) **United States Design Patent**
Triplett

(10) **Patent No.:** **US D984,671 S**

(45) **Date of Patent:** **** Apr. 25, 2023**

(54) **MORTAR AND PESTLE**

(71) Applicant: **Studio 010 Inc.**, Provo, UT (US)

(72) Inventor: **Tyson Triplett**, Provo, UT (US)

(73) Assignee: **Studio 010 Inc.**, Provo, UT (US)

(**) Term: **15 Years**

(21) Appl. No.: **29/761,541**

(22) Filed: **Dec. 9, 2020**

(51) **LOC (14) Cl.** **24-02**

(52) **U.S. Cl.**
USPC **D24/220; D7/682**

(58) **Field of Classification Search**
USPC D24/220; D27/196; D8/75; D7/682
(Continued)

(56) **References Cited**

U.S. PATENT DOCUMENTS

D33,632 S * 12/1900 Tucker D24/220
804,780 A 11/1905 Tetrault
(Continued)

FOREIGN PATENT DOCUMENTS

CA 2797527 C 11/2013
CN 202057530 U 11/2011
(Continued)

OTHER PUBLICATIONS

IMUSA USA Large Bamboo Mortar and Pestle. Mar. 4, 2010. Site visited Feb. 2, 2023. [https://www.amazon.com/IMUSA-BAM-10004-Bamboo-Mortar-Pestle/dp/B002NCV9VW/ref=asc_df_B002NCV9VW/?tag=hyprod-20&linkCode=df0&hvadid=198094063648&hvpos=&hvnetw=g&hvrnd=4329994500639239153&hvpone=&hvptwo=&hvqmt=&hvdev=c&hvdvcmidl=&hvlocint=&hvlocphy=1014895&hvtargid=pla-318359017416®ion_id=674469&th=1] (Year: 2010).*

(Continued)

Primary Examiner — Wendy L Arminio

Assistant Examiner — Maheen Khurshid

(74) *Attorney, Agent, or Firm* — Goff IP Law PLLC;
Jared S. Goff

(57) **CLAIM**

The ornamental design for a mortar and pestle, as shown and described.

DESCRIPTION

FIG. 1 is a front top perspective view of a mortar and pestle in a first configuration.

FIG. 2 is a rear bottom perspective view of the mortar and pestle as configured in FIG. 1.

FIG. 3 is a front view of the mortar and pestle as configured in FIG. 1. A rear view of the mortar and pestle as configured in FIG. 1 is the same as the front view.

FIG. 4 is a right side view of the mortar and pestle as configured in FIG. 1. A left side view of the mortar and pestle as configured in FIG. 1 is the same as the right side view.

FIG. 5 is a top view of the mortar and pestle as configured in FIG. 1.

FIG. 6 is a bottom view of the mortar and pestle as configured in FIG. 1.

FIG. 7 is a sectional view taken along line 7-7 of FIG. 3.

FIG. 8 is a sectional view taken along line 8-8 of FIG. 4.

FIG. 9 is a sectional view taken along line 9-9 of FIG. 3.

FIG. 10 is a front top perspective view of the mortar and pestle of FIG. 1 in a second configuration.

FIG. 11 is a front bottom perspective view of the mortar and pestle as configured in FIG. 10.

FIG. 12 is a front view of the mortar and pestle as configured in FIG. 10. A rear view of the mortar and pestle as configured in FIG. 10 is a mirror image of the front view.

FIG. 13 is a left side view of the mortar and pestle as configured in FIG. 10.

FIG. 14 is a right side view of the mortar and pestle as configured in FIG. 10.

FIG. 15 is a top view of the mortar and pestle as configured in FIG. 10.

(Continued)

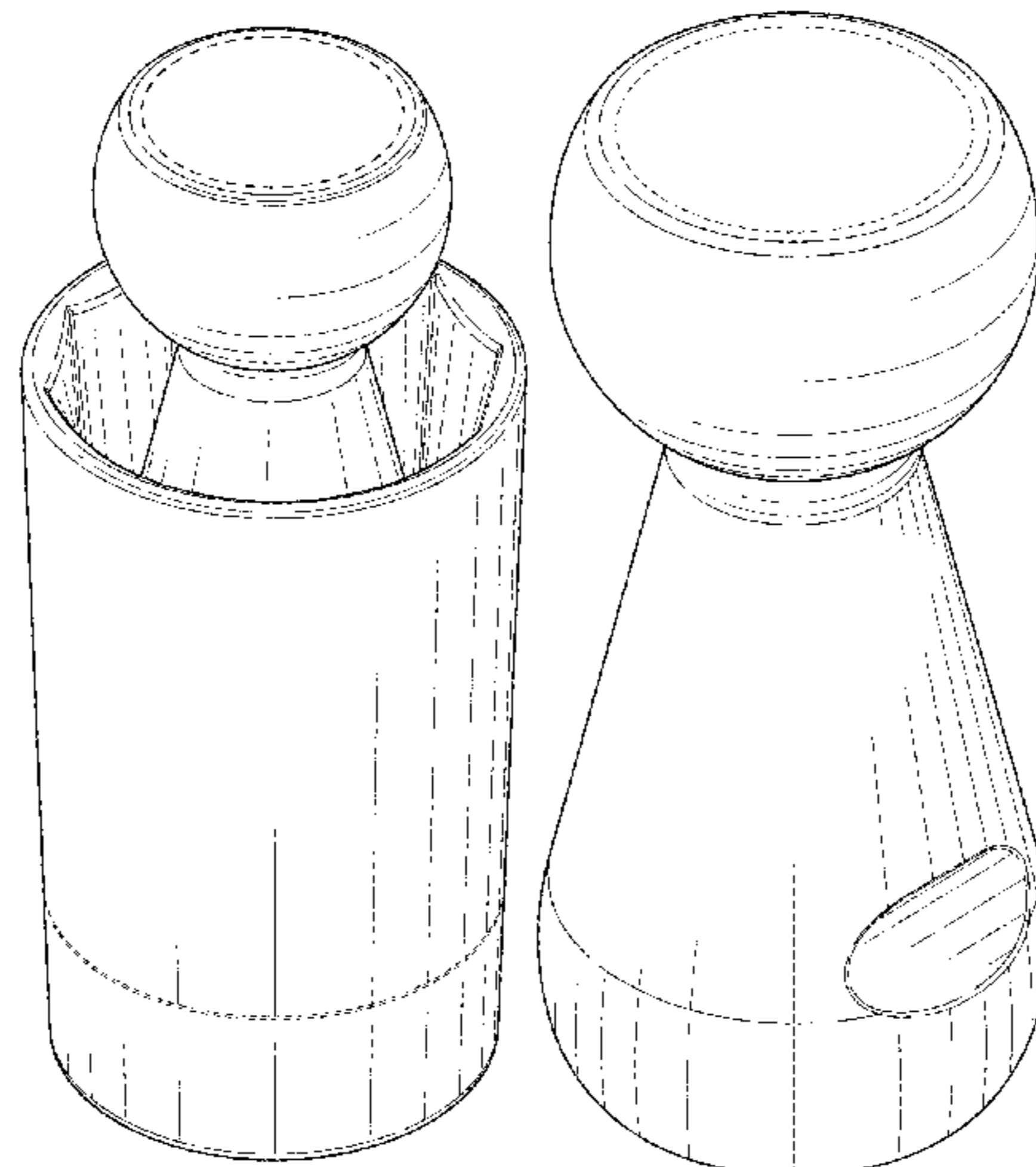

FIG. 16 is a bottom view of the mortar and pestle as configured in FIG. 10.
 FIG. 17 is a sectional view taken along line 17-17 of FIG. 12.
 FIG. 18 is a sectional view taken along line 18-18 of FIG. 13.
 FIG. 19 is a sectional view taken along line 19-19 of FIG. 12.
 FIG. 20 is a front top perspective view of the pestle of the mortar and pestle of FIG. 1.
 FIG. 21 is a rear bottom perspective view of the pestle of FIG. 20.
 FIG. 22 is a front view of the pestle of FIG. 20. A rear view of the pestle of FIG. 20 is the same as the front view.
 FIG. 23 is a right side view of the pestle of FIG. 20. A left side view the pestle of FIG. 20 is the same as the right side view.
 FIG. 24 is a top view of the pestle of FIG. 20.
 FIG. 25 is a bottom view of the pestle of FIG. 20.
 FIG. 26 is a front top perspective view of the mortar of the mortar and pestle of FIG. 1.
 FIG. 27 is a bottom rear perspective view of the mortar of FIG. 26.
 FIG. 28 is a front view of the mortar of FIG. 26. A rear view of the mortar of FIG. 26 is the same as the front view.
 FIG. 29 is a right side view of the mortar of FIG. 26. A left side view of the mortar of FIG. 26 is the same as the right side view.
 FIG. 30 is a top view of the mortar of FIG. 26.
 FIG. 31 is a bottom view of the mortar of FIG. 26.
 FIG. 32 is a sectional view taken along line 32-32 of FIG. 29.
 FIG. 33 is a sectional view taken along line 33-33 of FIG. 28.
 FIG. 34 is a perspective sectional view taken along line 34-34 of FIG. 28; and,
 FIG. 35 is a perspective sectional view taken along line 35-35 of FIG. 29.

The broken lines and unshaded surfaces bounded by broken lines form no part of the claimed design.

1 Claim, 20 Drawing Sheets

(58) **Field of Classification Search**
 CPC B02C 19/08; B02C 17/186; B02C 23/12
 See application file for complete search history.

(56) **References Cited**

U.S. PATENT DOCUMENTS

D50,471 S *	3/1917	Grier	D24/220
1,485,618 A	3/1924	Kellogg	
1,878,263 A *	9/1932	Chott	A61C 5/68 241/199.9
2,161,998 A	6/1939	Chott	
2,318,911 A	5/1943	Zweber	
2,345,474 A	3/1944	Haverland	
2,795,383 A *	6/1957	Reich	B02C 19/08 215/280
2,892,595 A	6/1959	Tupper	
3,107,063 A	10/1963	Nyberg	
3,136,491 A	6/1964	Posmanter	
3,450,355 A	6/1969	Murphy	
D231,923 S *	6/1974	Johnsrud	D7/682

3,865,551 A	2/1975	Saiki et al.	
4,003,523 A	1/1977	Doolittle	
4,121,775 A	10/1978	Roseberg et al.	
4,209,136 A	6/1980	Linden et al.	
4,212,430 A	7/1980	Dale et al.	
4,341,356 A *	7/1982	Hiott	B02C 19/08 241/199.9
4,348,950 A *	9/1982	Harris	A47J 19/06 241/168
4,366,930 A	1/1983	Trombetti, Jr.	
4,967,971 A	11/1990	Smith	
5,178,337 A	1/1993	Lupoli	
5,618,004 A	4/1997	Klearman et al.	
5,806,772 A	9/1998	Karra	
D406,019 S *	2/1999	La Gro	D27/196
D425,065 S *	5/2000	Frances	D24/220
D490,160 S *	5/2004	Sorensen	D24/220
7,032,851 B2	4/2006	Demske et al.	
D543,634 S *	5/2007	Lundstrom	D24/220
D642,023 S *	7/2011	Reay	D7/682
7,975,943 B1	7/2011	Culves	
8,087,602 B1	1/2012	Teng	
9,010,669 B2	4/2015	Priebe et al.	
9,346,058 B2	5/2016	Yamamoto et al.	
D776,294 S	1/2017	Sharpe et al.	
D827,148 S *	8/2018	Lam	D7/682
10,548,813 B2	2/2020	Evans	
D883,512 S *	5/2020	Zhou	D24/220
D906,069 S *	12/2020	Tevel	D8/75
2009/0014564 A1	1/2009	Grah	
2009/0038485 A1 *	2/2009	Kavanaugh	B02C 19/08 426/481
2009/0212143 A1	8/2009	Teng	
2012/0305685 A1	12/2012	Yamamoto et al.	
2016/0310366 A1	10/2016	Evans	
2019/0091104 A1	3/2019	Yang et al.	

FOREIGN PATENT DOCUMENTS

CN	104289291 A	1/2015
CN	104959205 A	10/2015
CN	106733059 A	5/2017
CN	106902951 A	6/2017
CN	107007471 A	8/2017
CN	107982067 A	5/2018
CN	108262129 A	7/2018
CN	108362534 A	8/2018
CN	109549851 A	4/2019
CN	307753620 *	12/2022
EP	2529837 A2	12/2012
GB	367112	2/1932
GB	2399518 A	9/2004
GB	6014345 *	6/2017
KR	20120135474 A	12/2012
KR	20190000995 U	4/2019
WO	9516427 A1	6/1995

OTHER PUBLICATIONS

Samhita Handmade Acacia Wood Mortar and Pestle. Jun. 11, 2021. Site visited Feb. 2, 2023. [https://www.amazon.com/Samhita-Handmade-Perfect-Grinder-Essentials/dp/B0972M8VRF/ref=sr_1_13?crd=33ED42TVECB8X&keywords=mortar+and+pestle+tall+thin+narrow&qid=1675384395&sprefix=mortar+and+pestle+tall+thin+narrow%2Caps%2C120&sr=8-13] (Year: 2021).*

Kota Japan Large Granite Mortar & Pestle. Feb. 14, 2017. Site visited Feb. 2, 2023. [https://www.amazon.com/Kota-Japan-Natural-Seasonings-Guacamole/dp/B06W2KBC4Z/ref=sr_1_9?crd=33ED42TVECB8X&keywords=mortar+and+pestle+tall+thin+narrow&qid=1675384395&sprefix=mortar+and+pestle+tall+thin+narrow%2Caps%2C120&sr=8-9] (Year: 2017).*

* cited by examiner

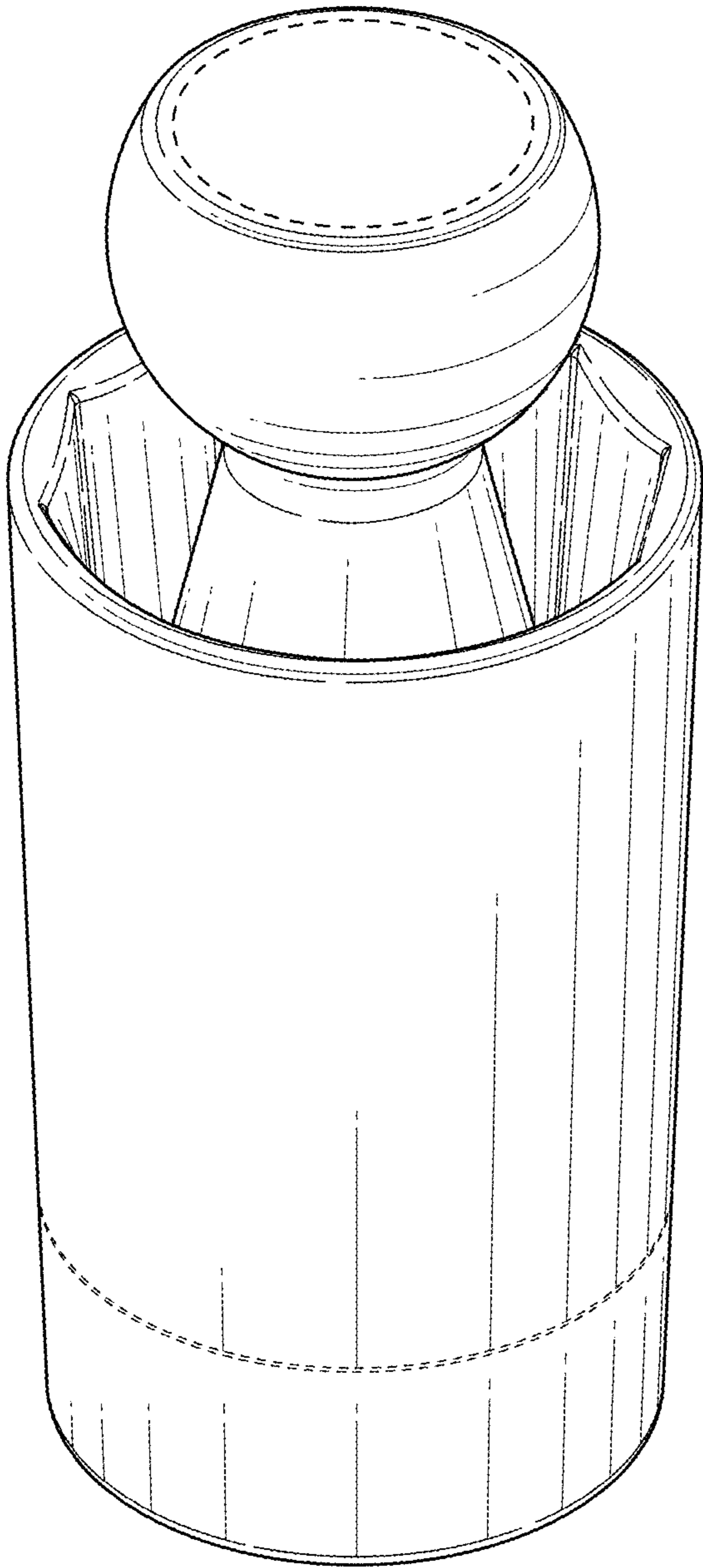

FIG. 1

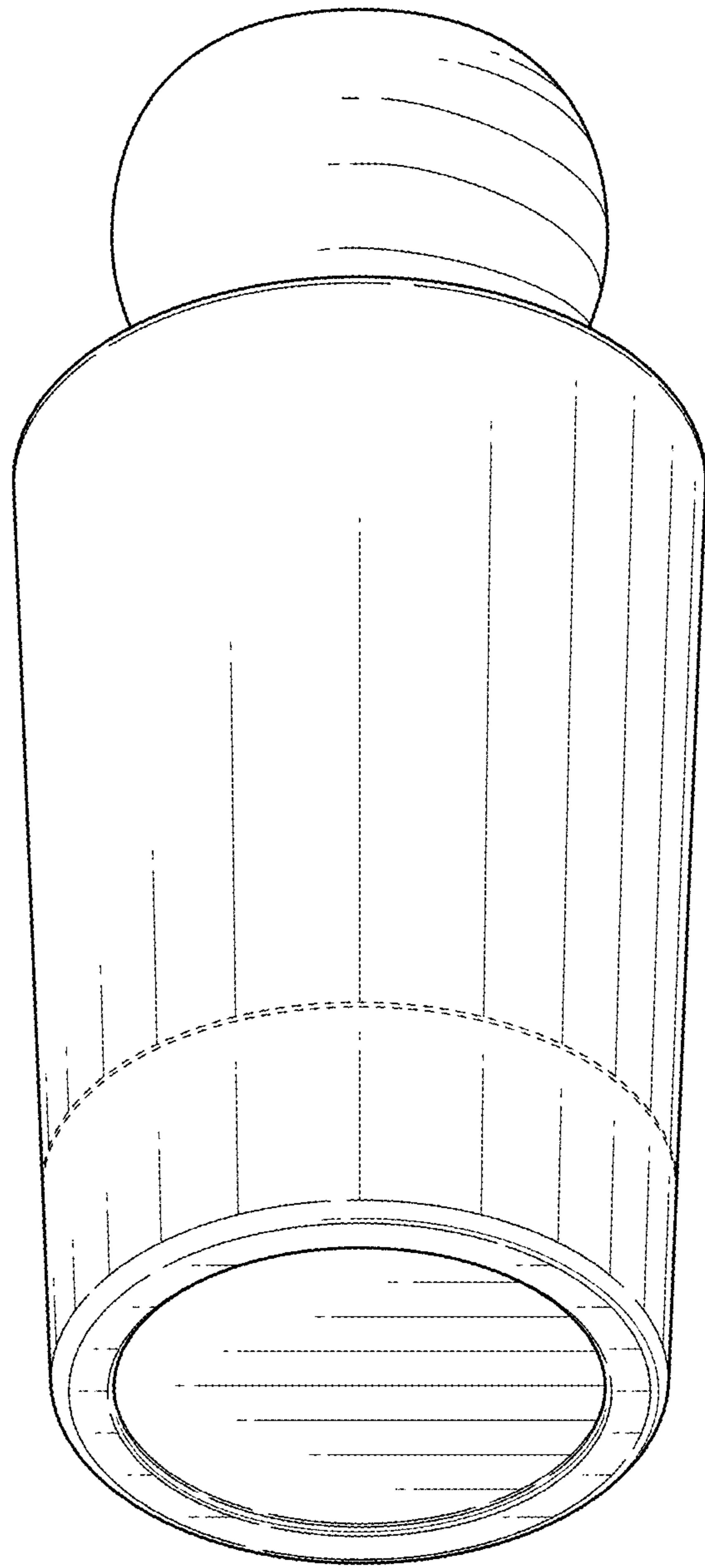

FIG. 2

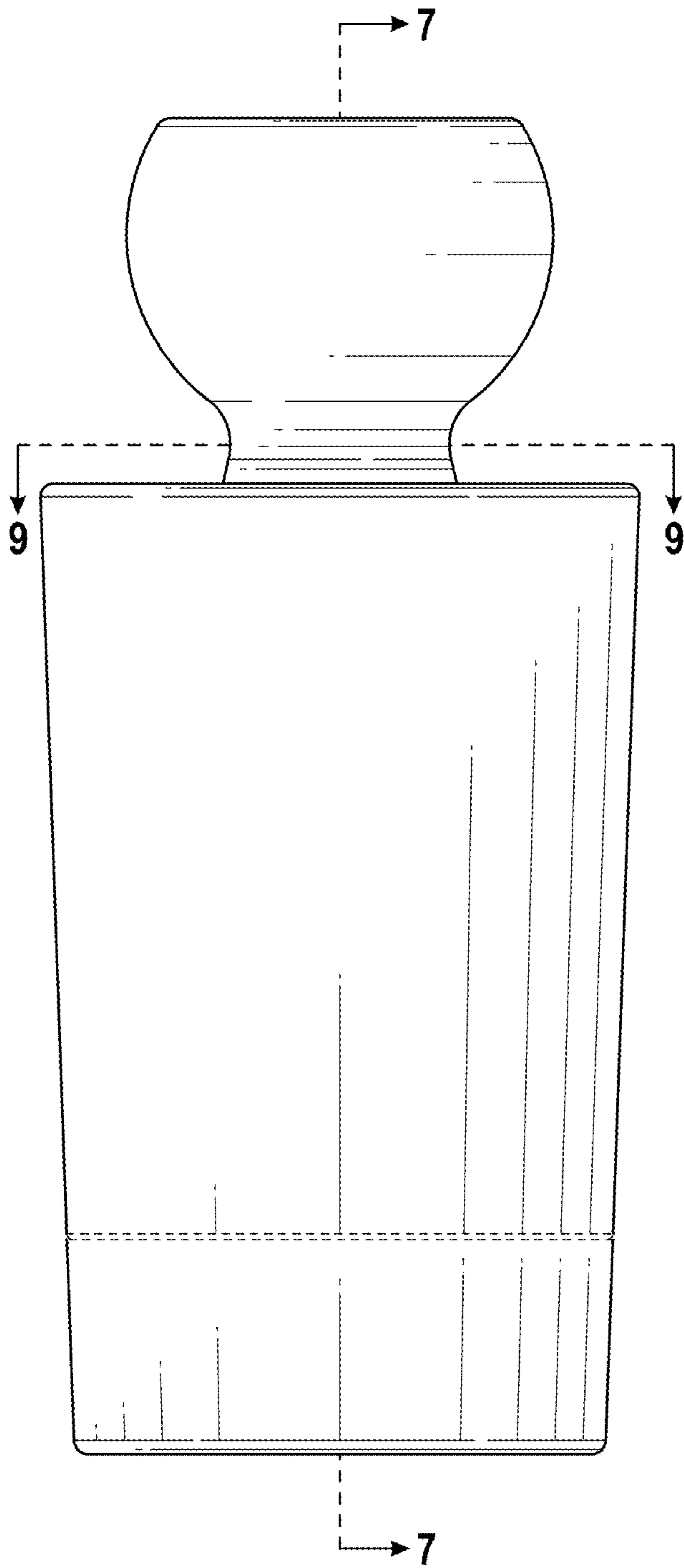

FIG. 3

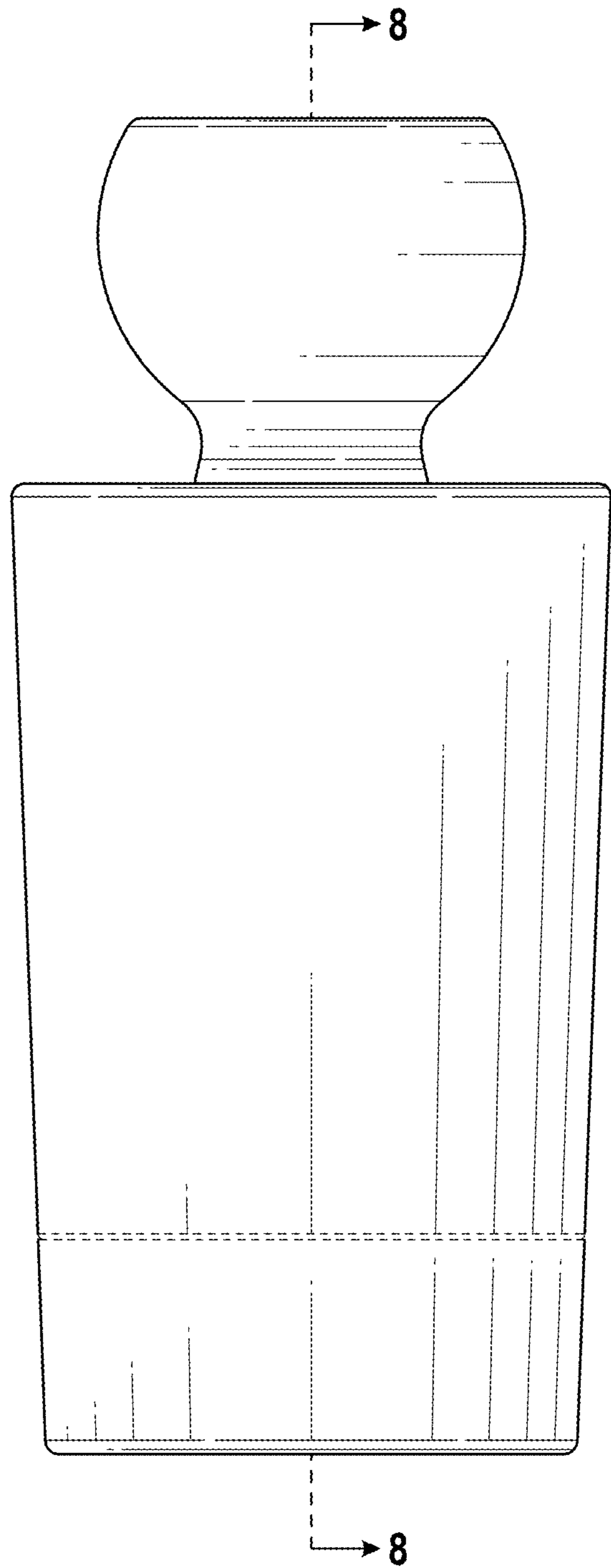

FIG. 4

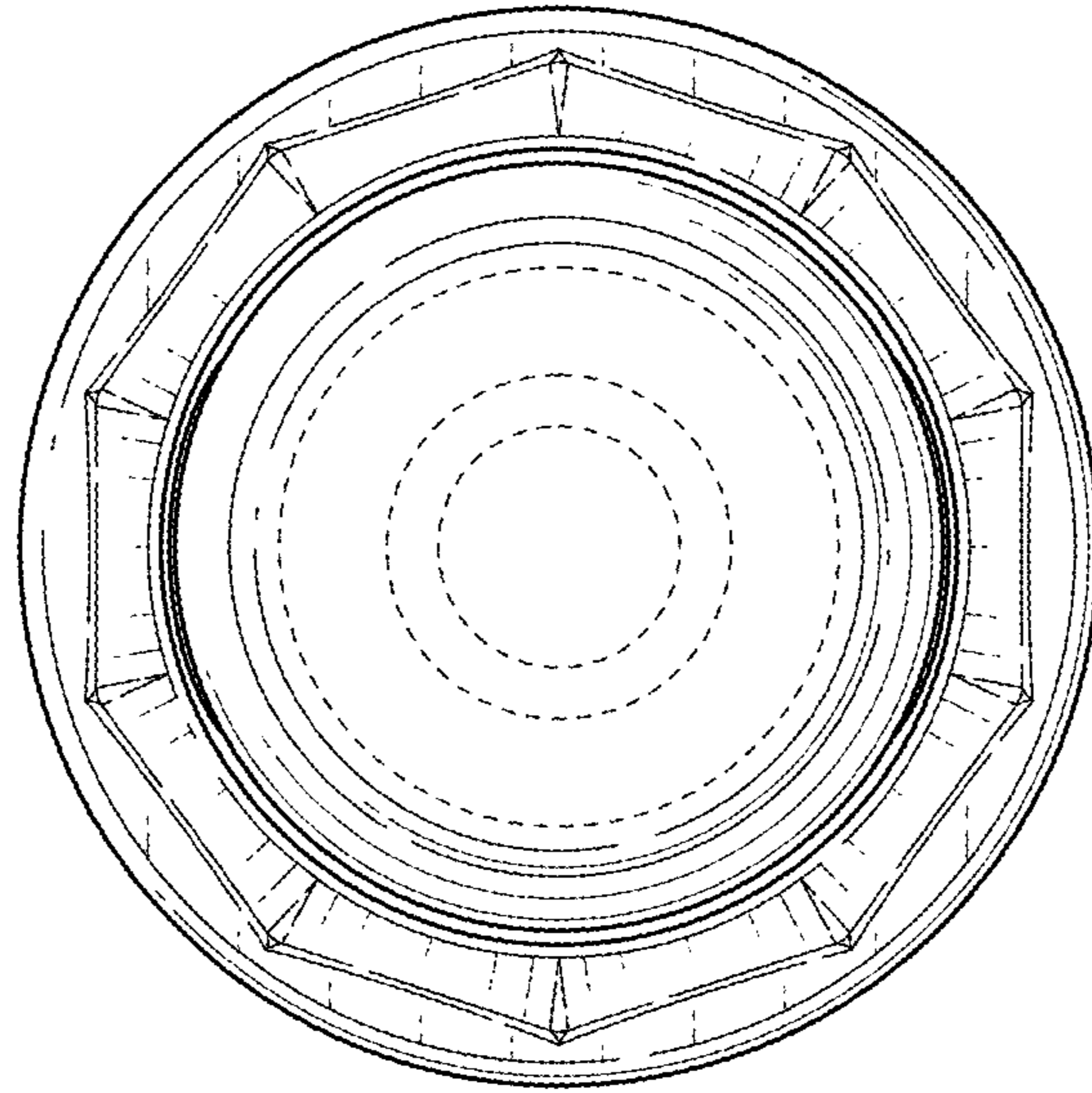

FIG. 5

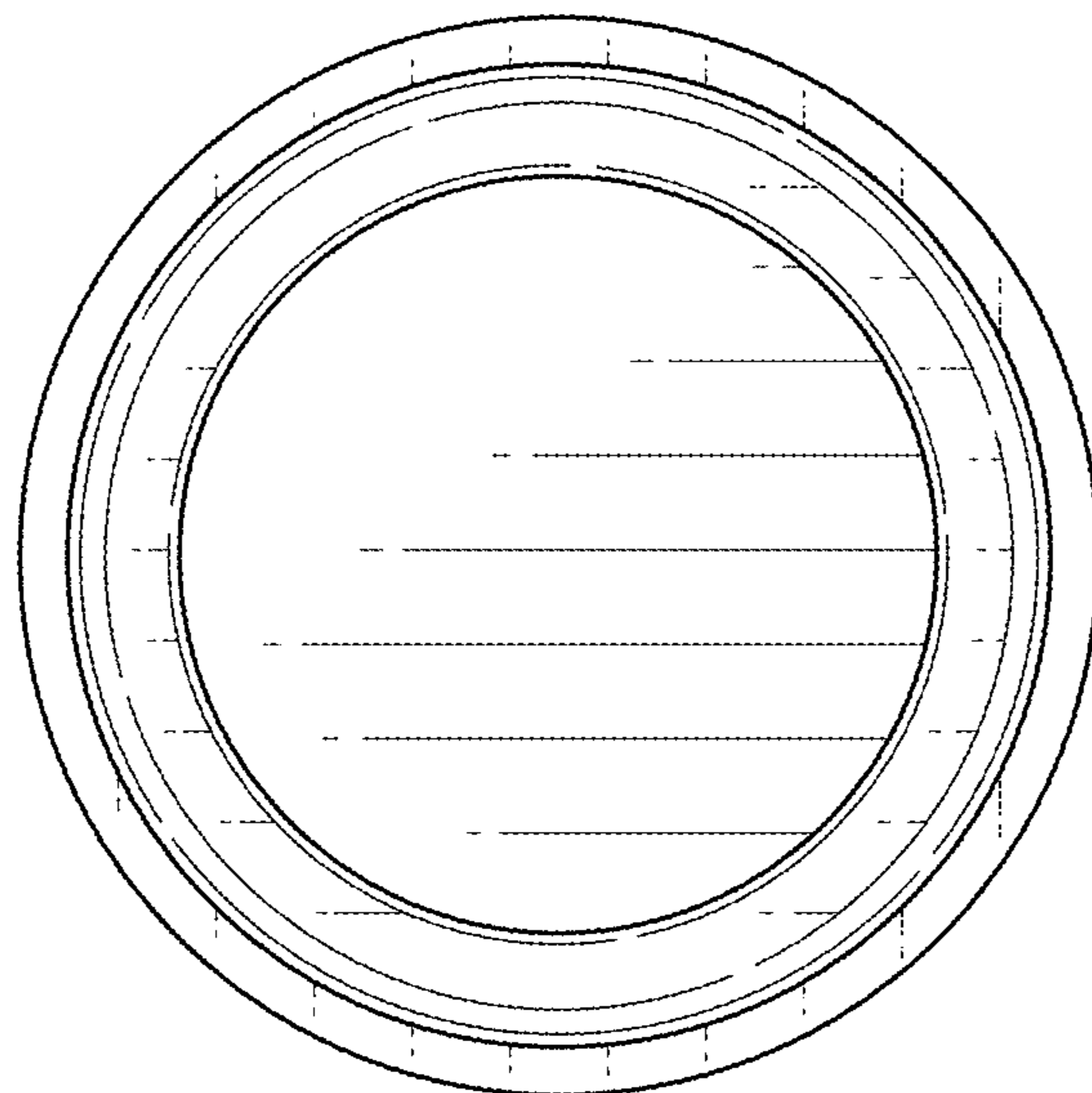

FIG. 6

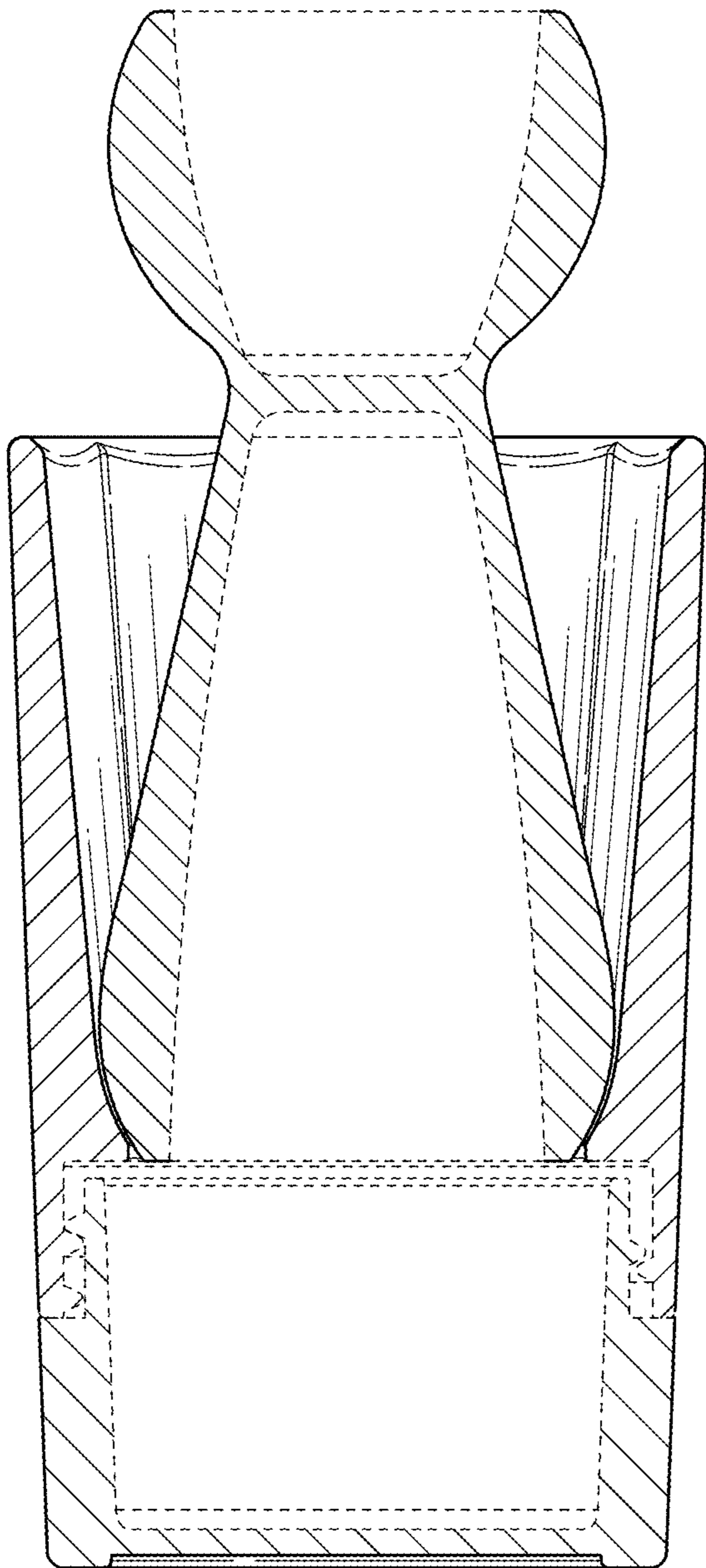

FIG. 7

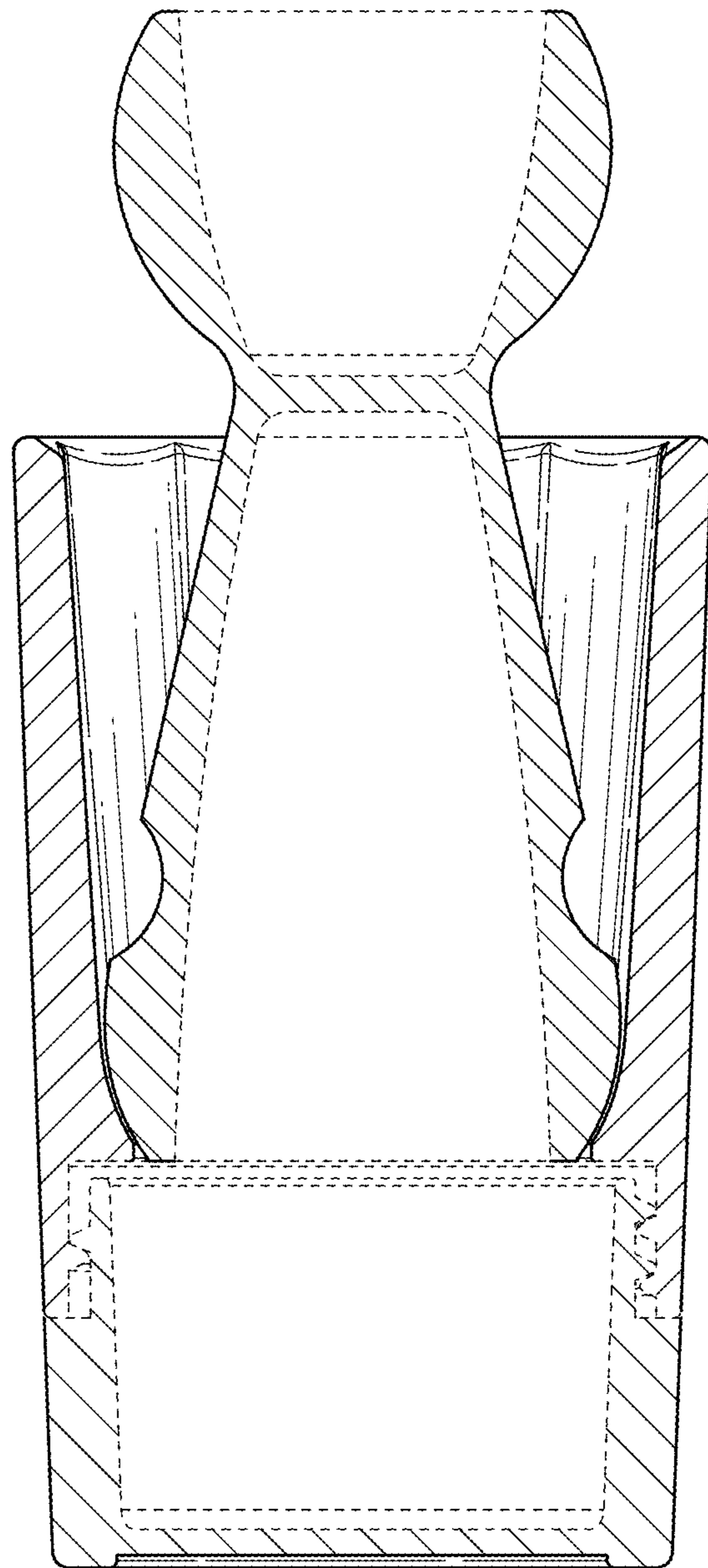

FIG. 8

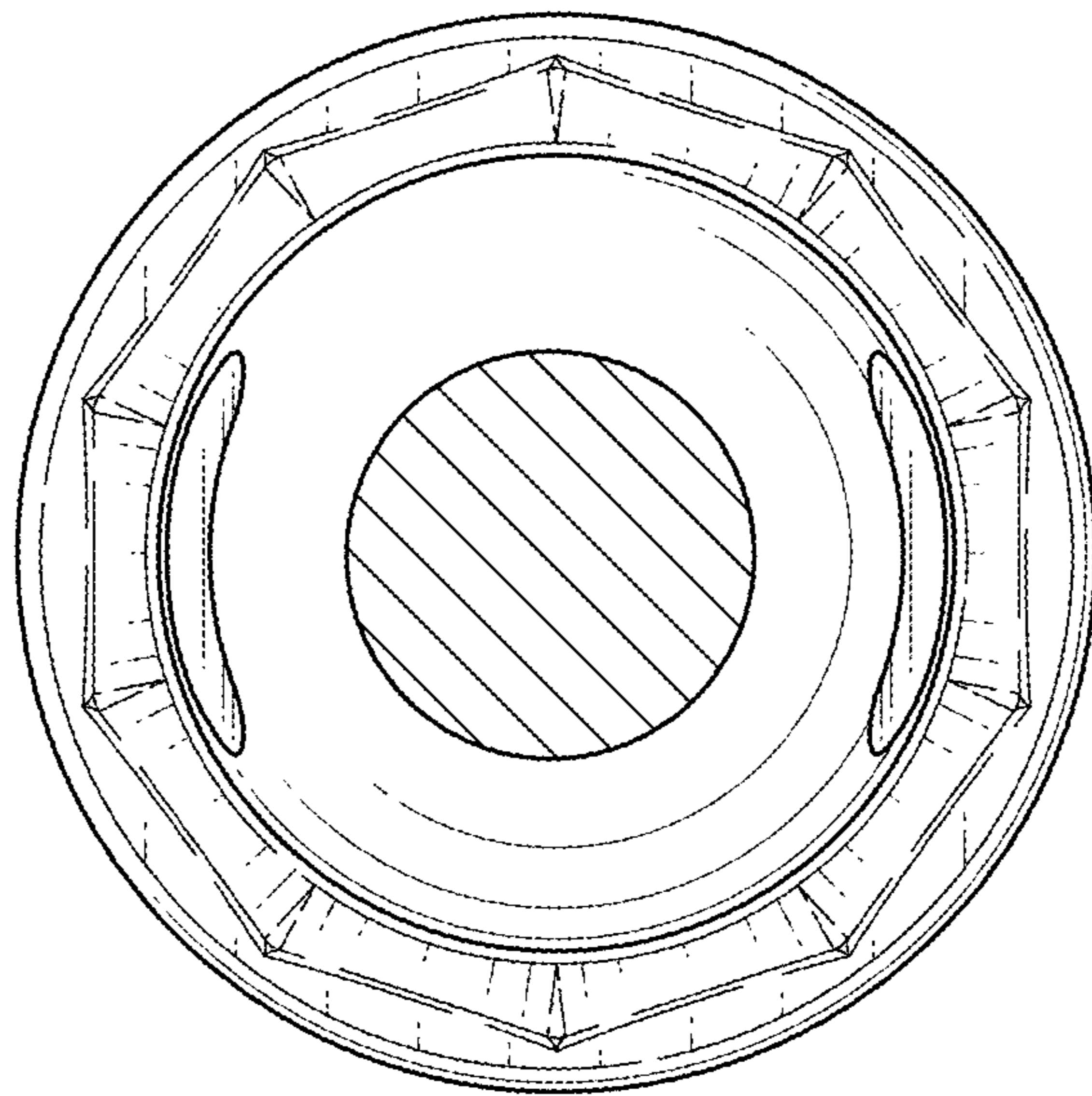

FIG. 9

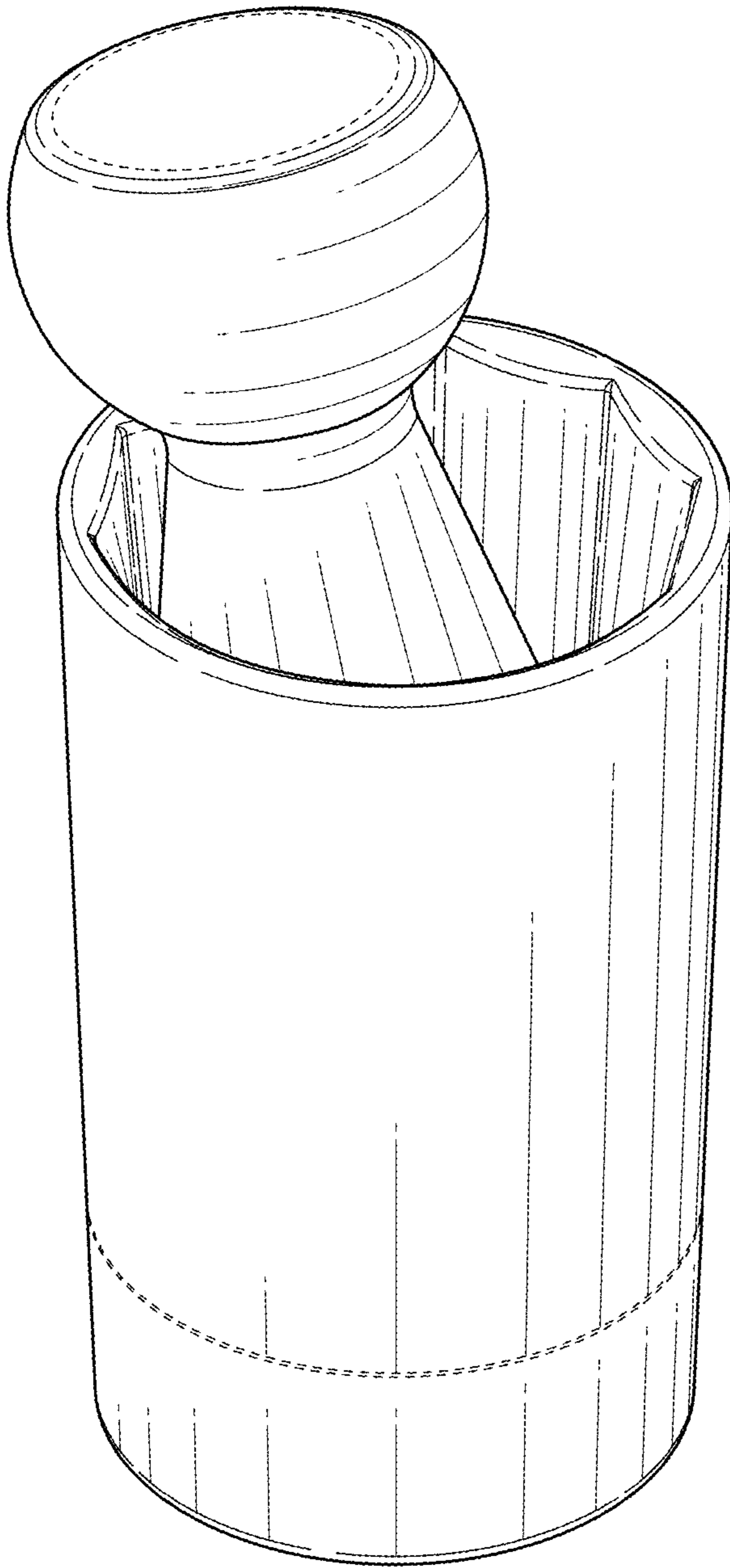

FIG. 10

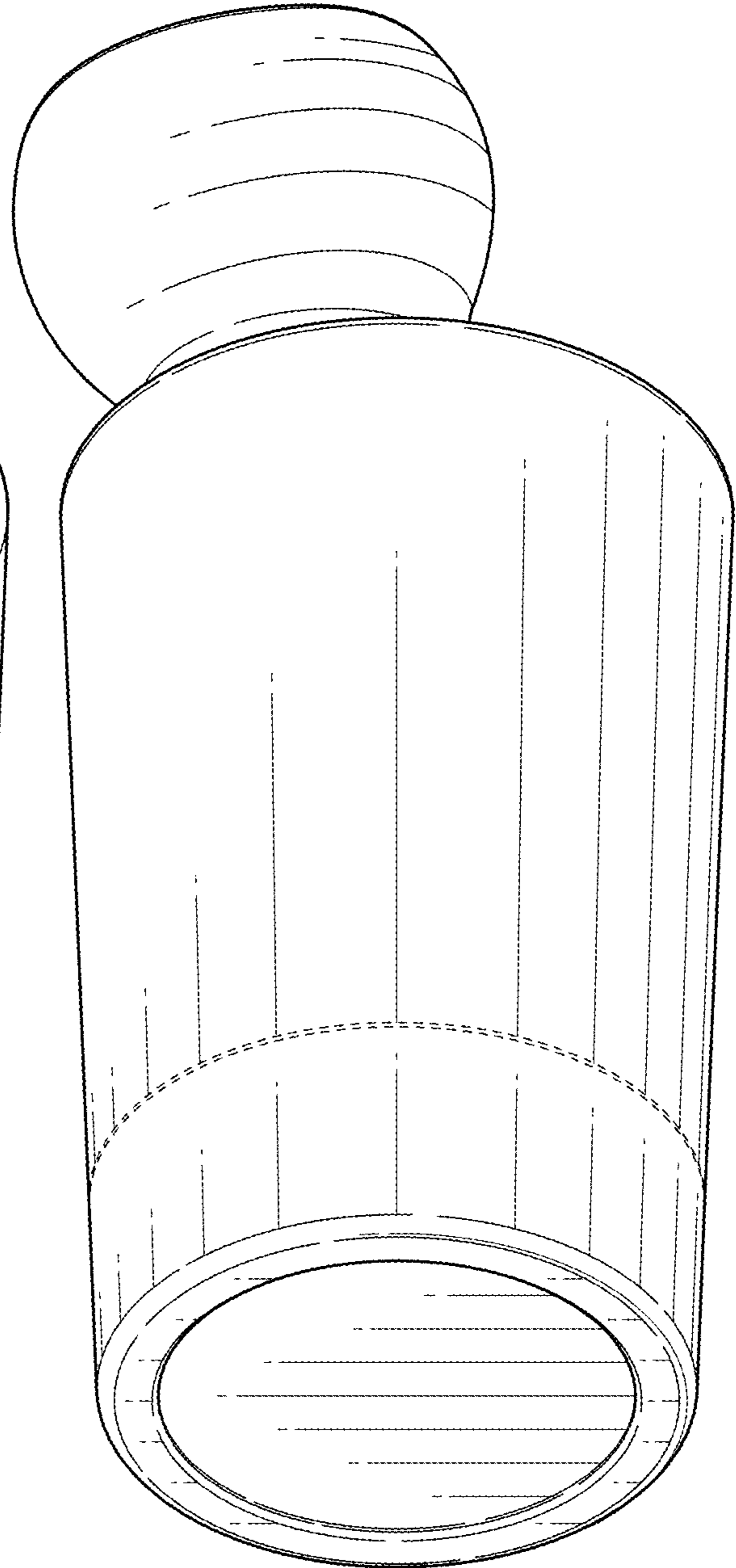

FIG. 11

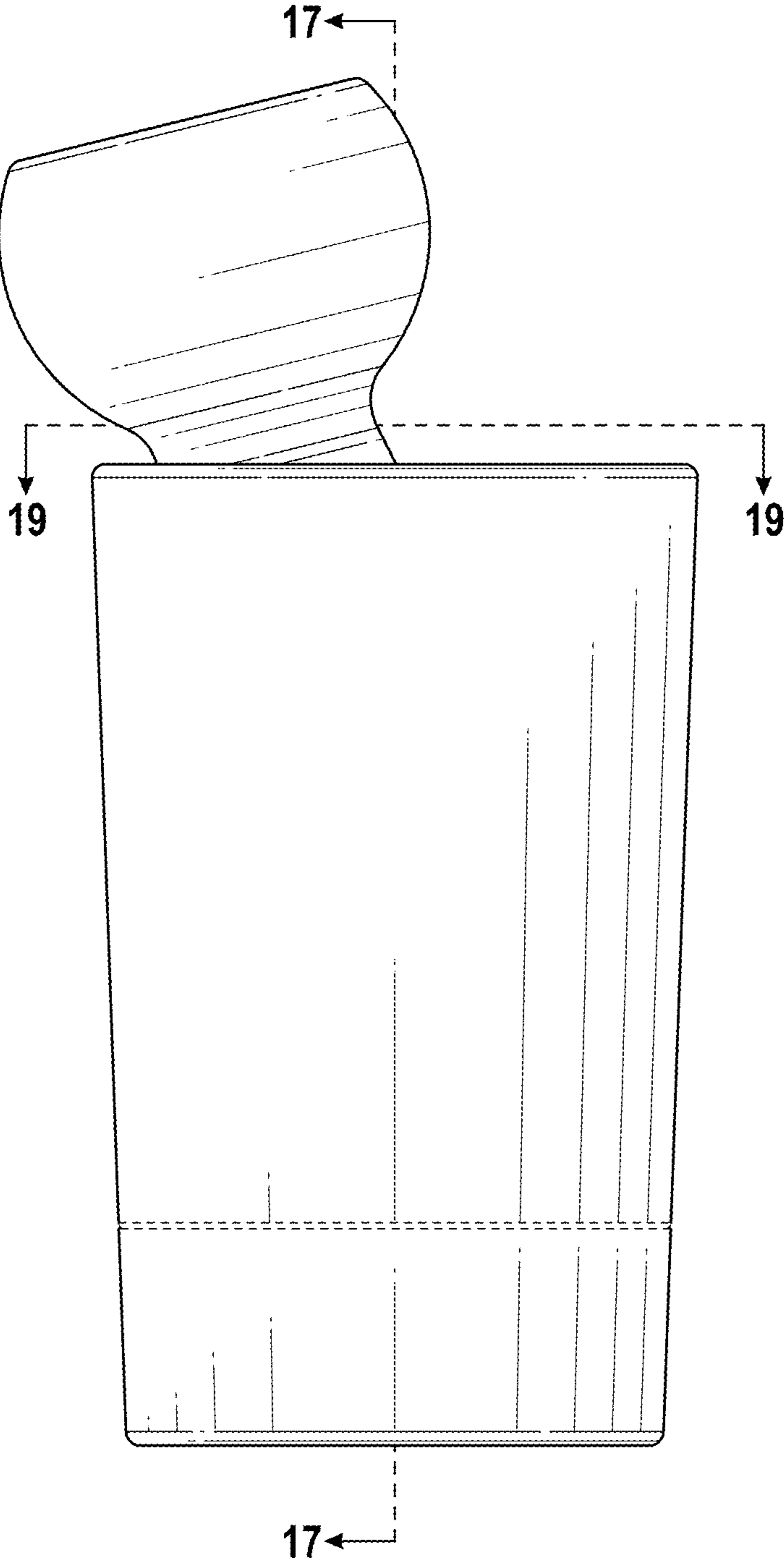
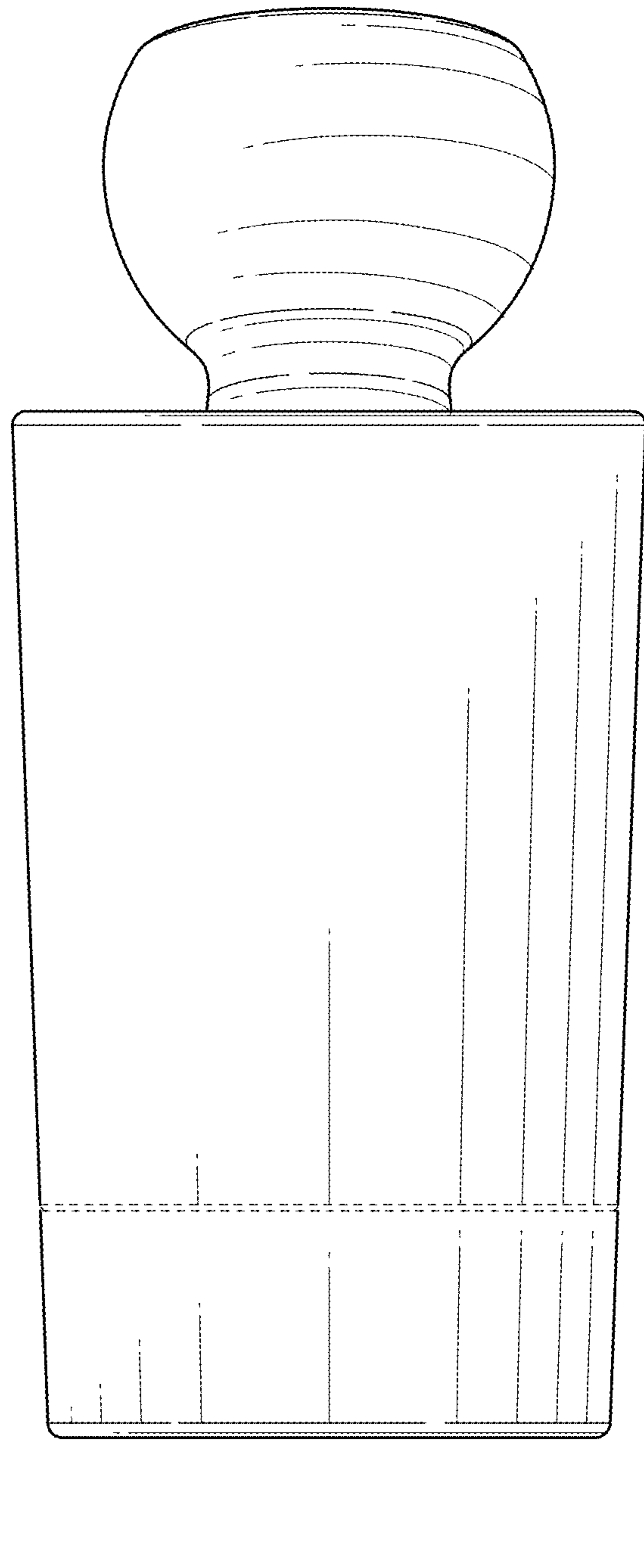
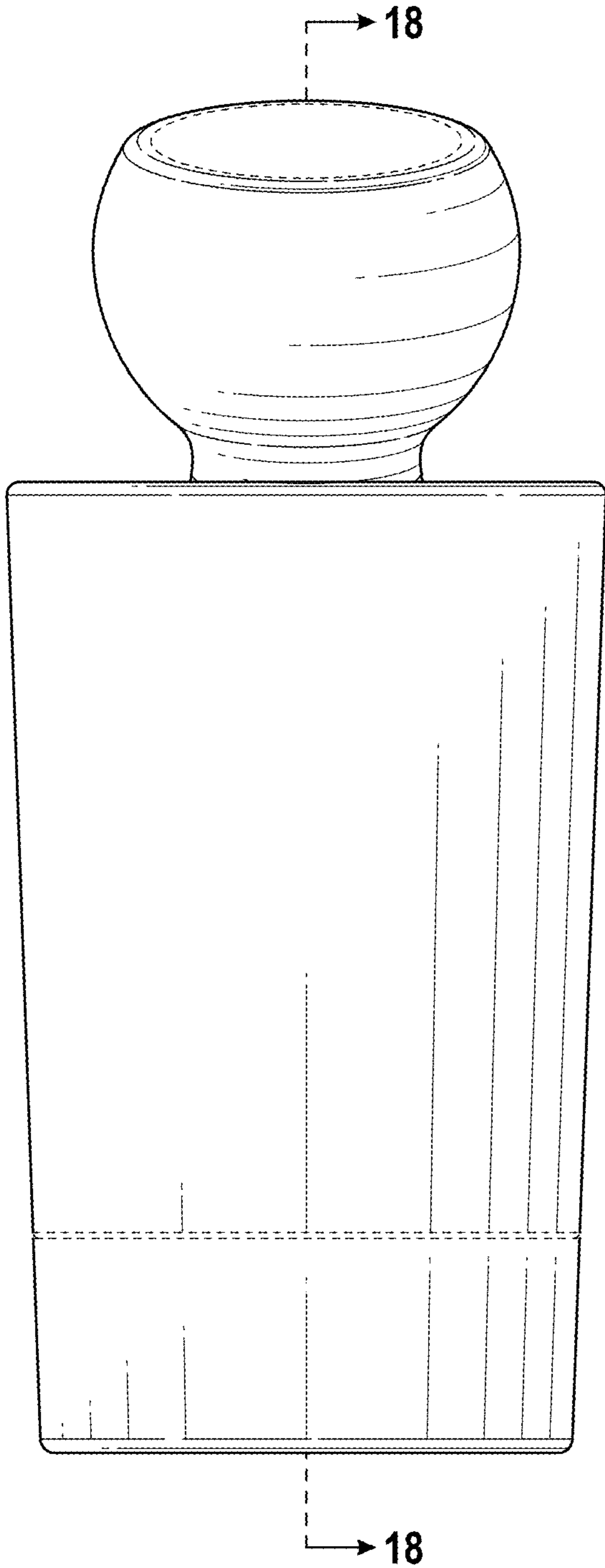

FIG. 12



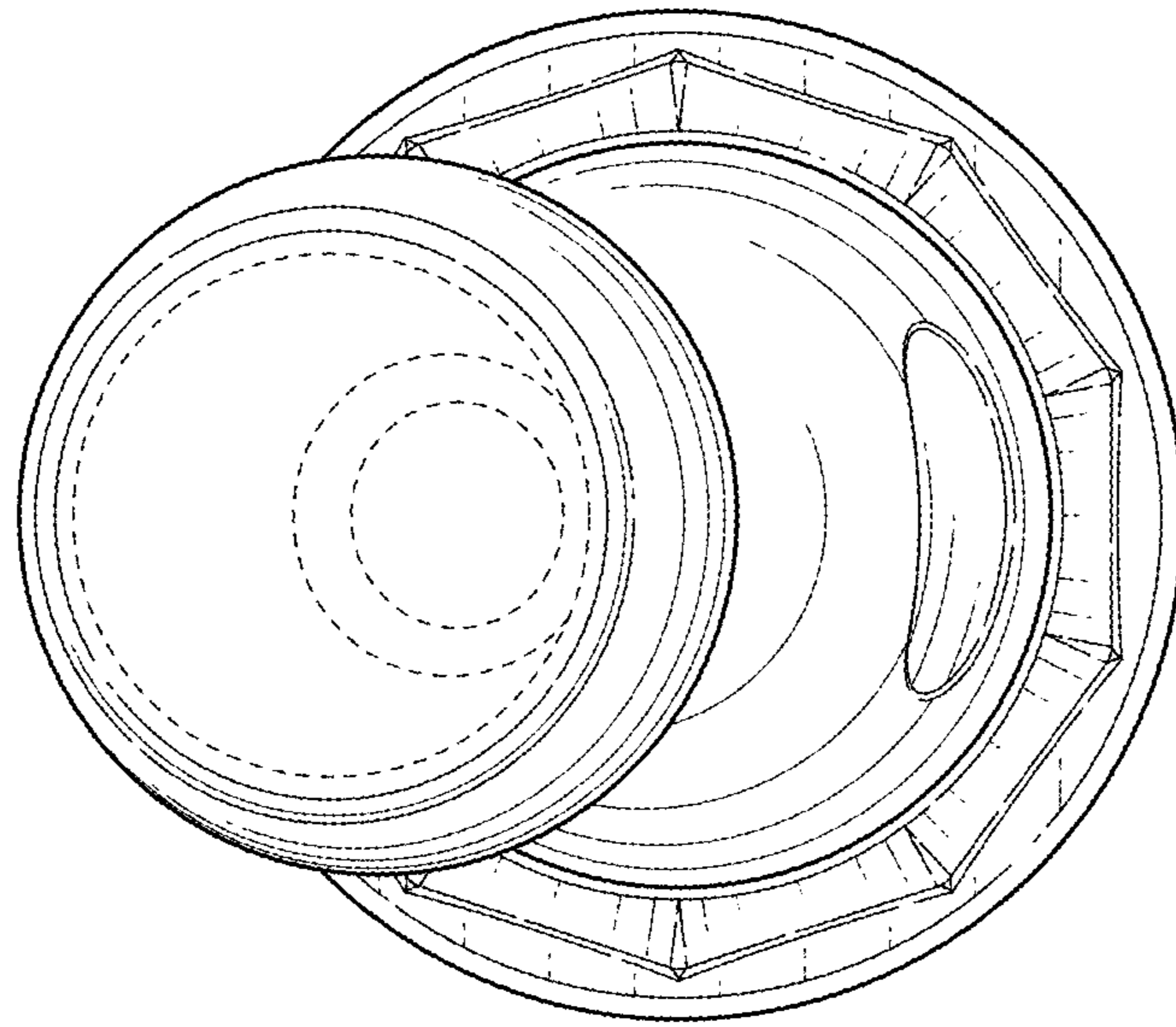

FIG. 15

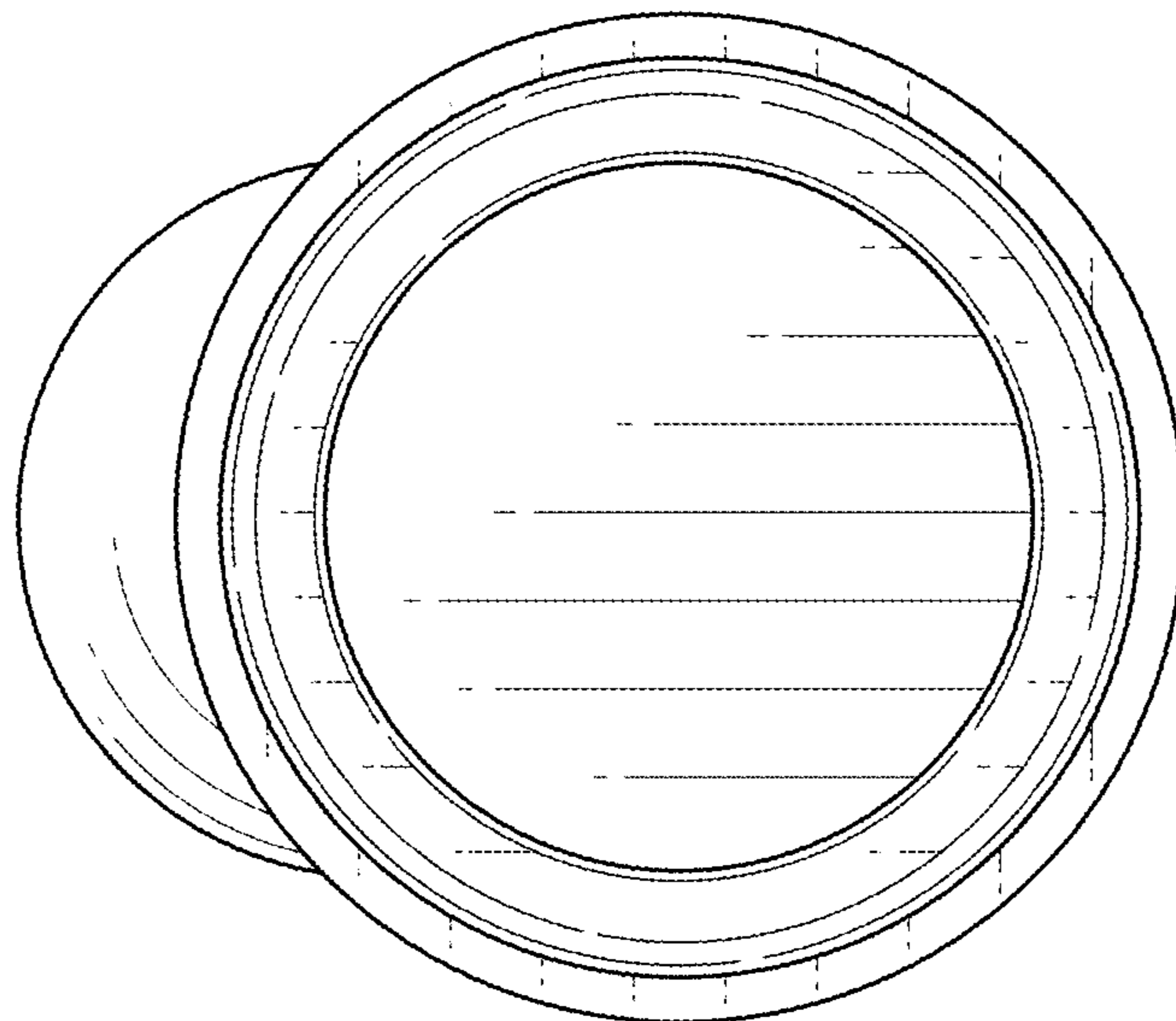

FIG. 16

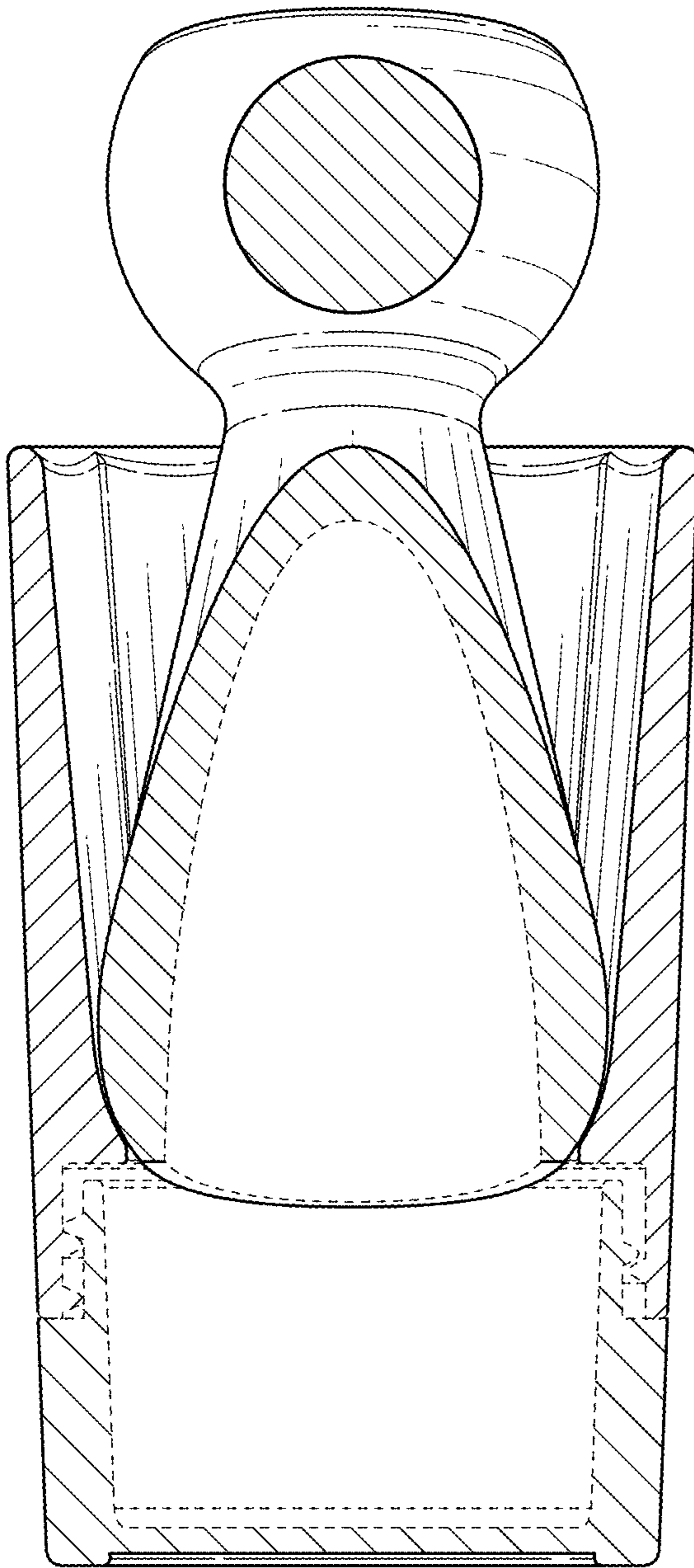

FIG. 17

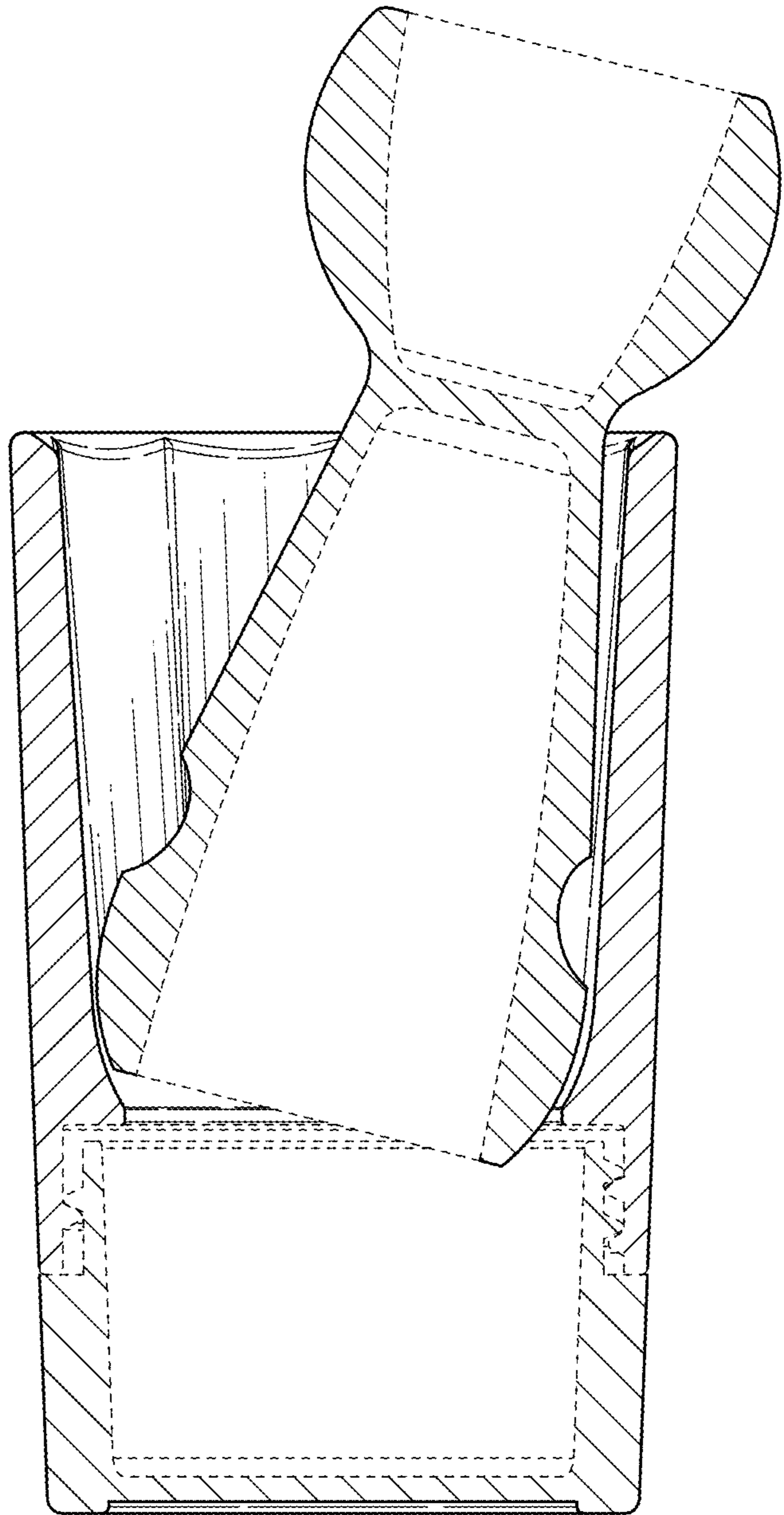

FIG. 18

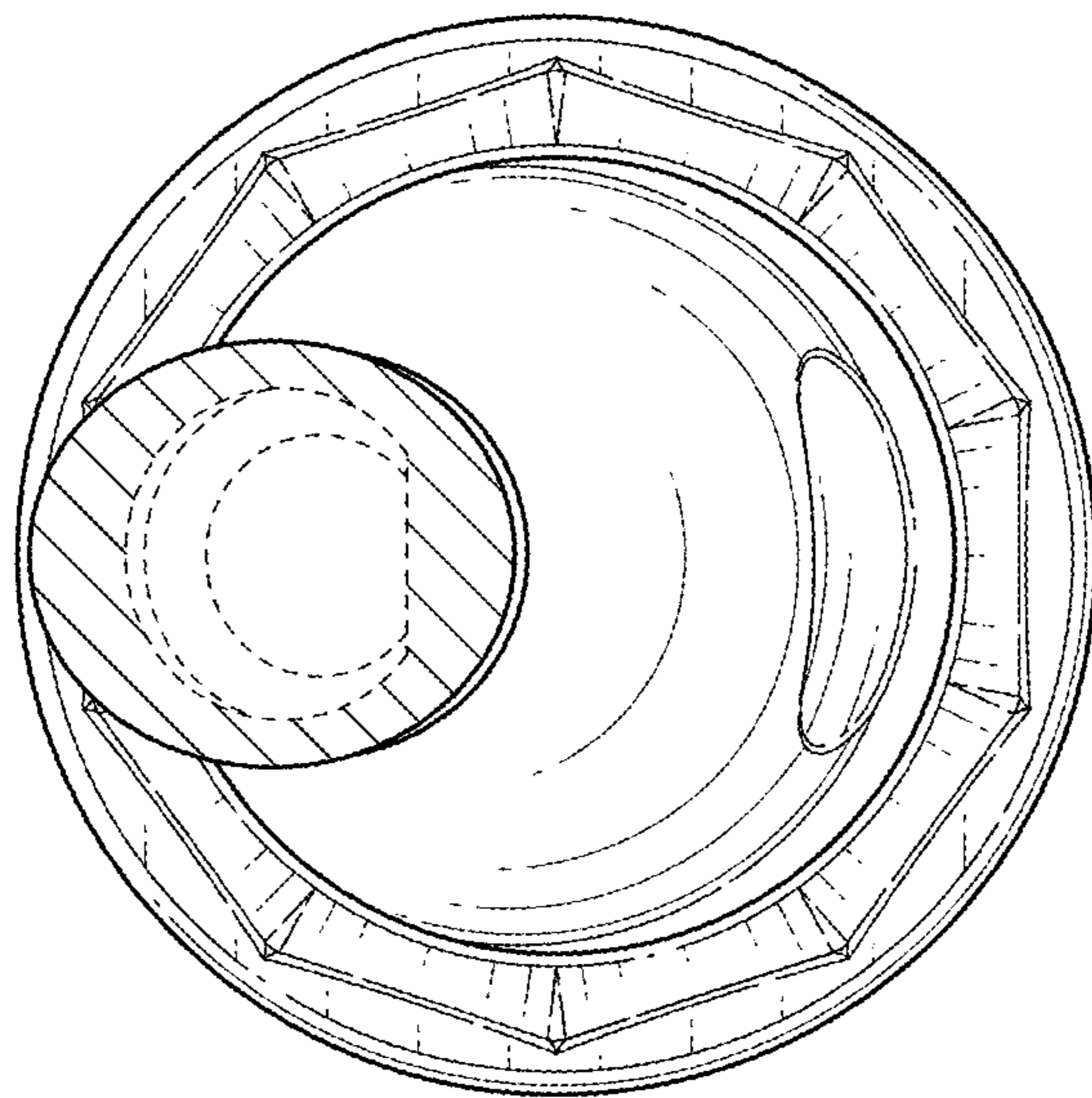

FIG. 19

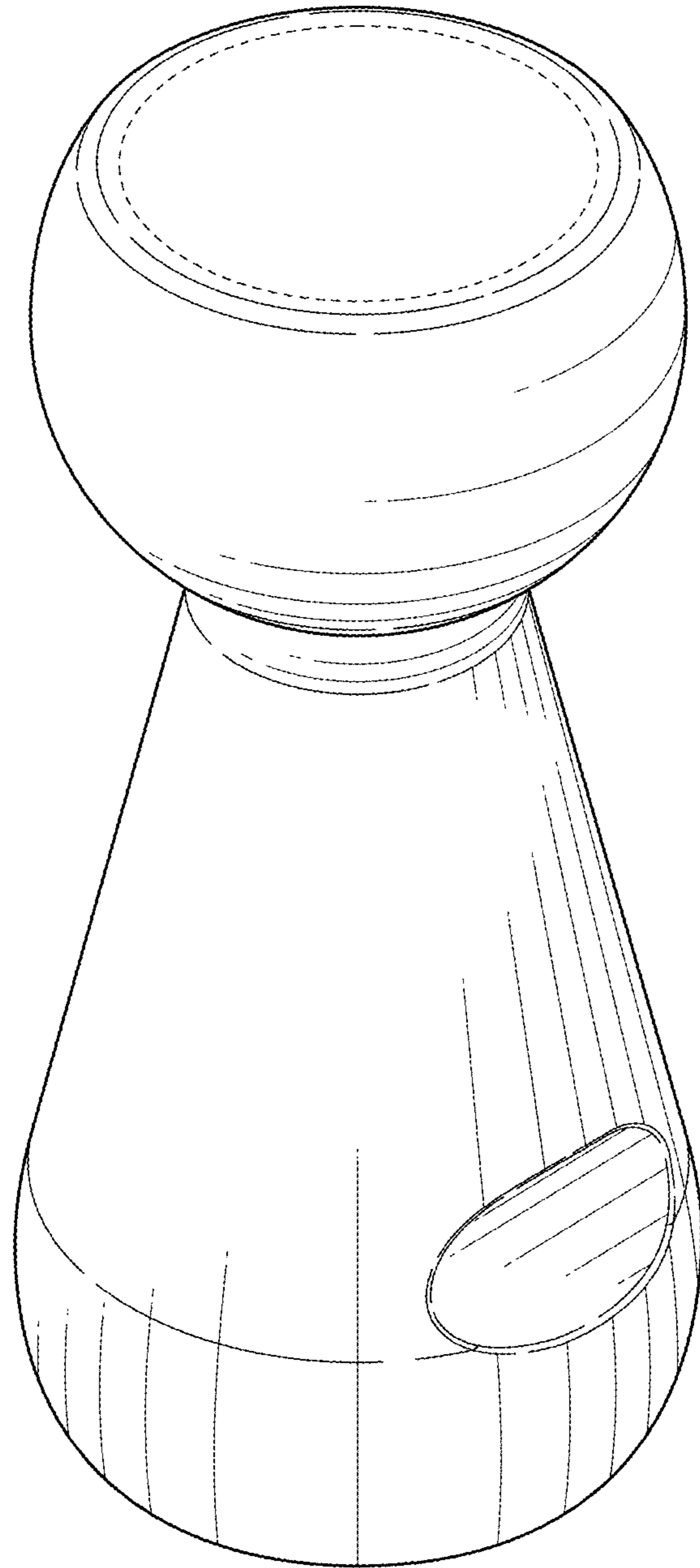

FIG. 20

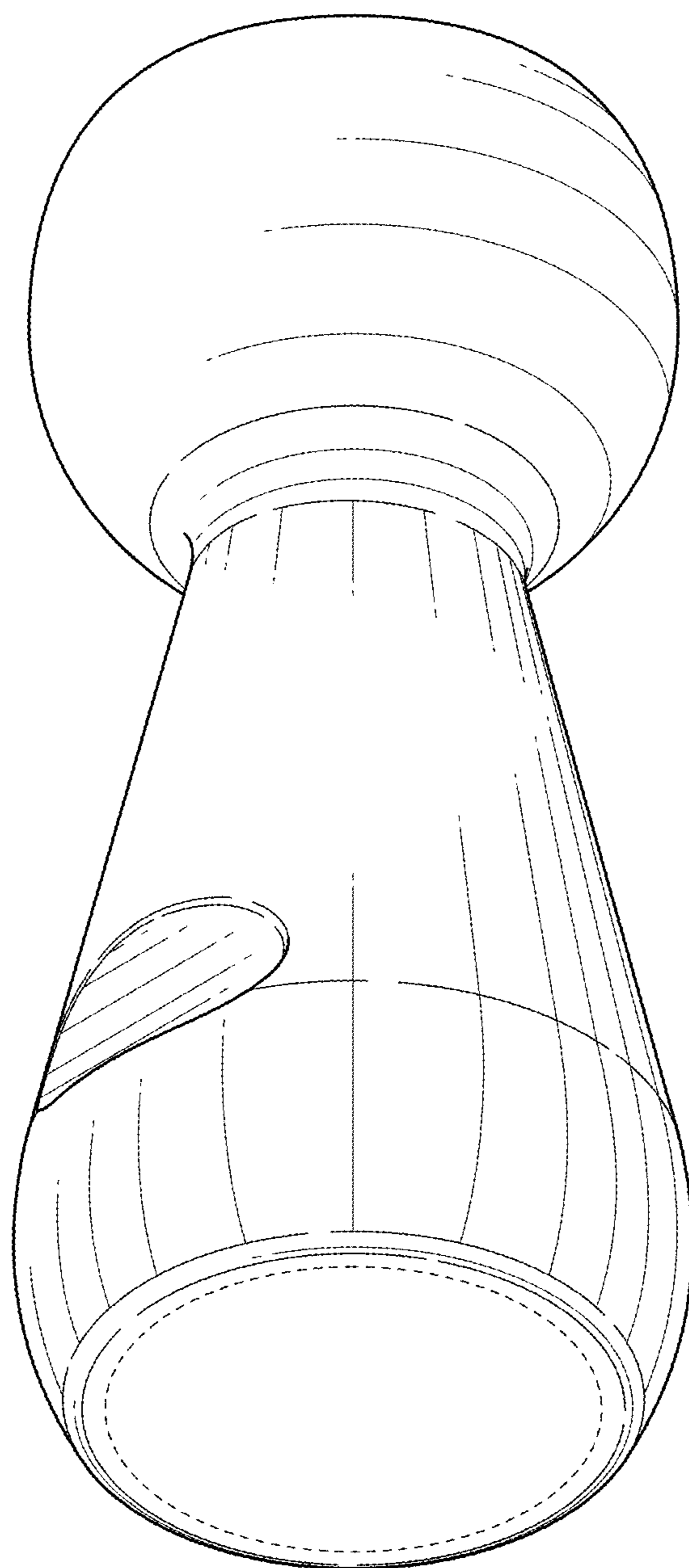

FIG. 21

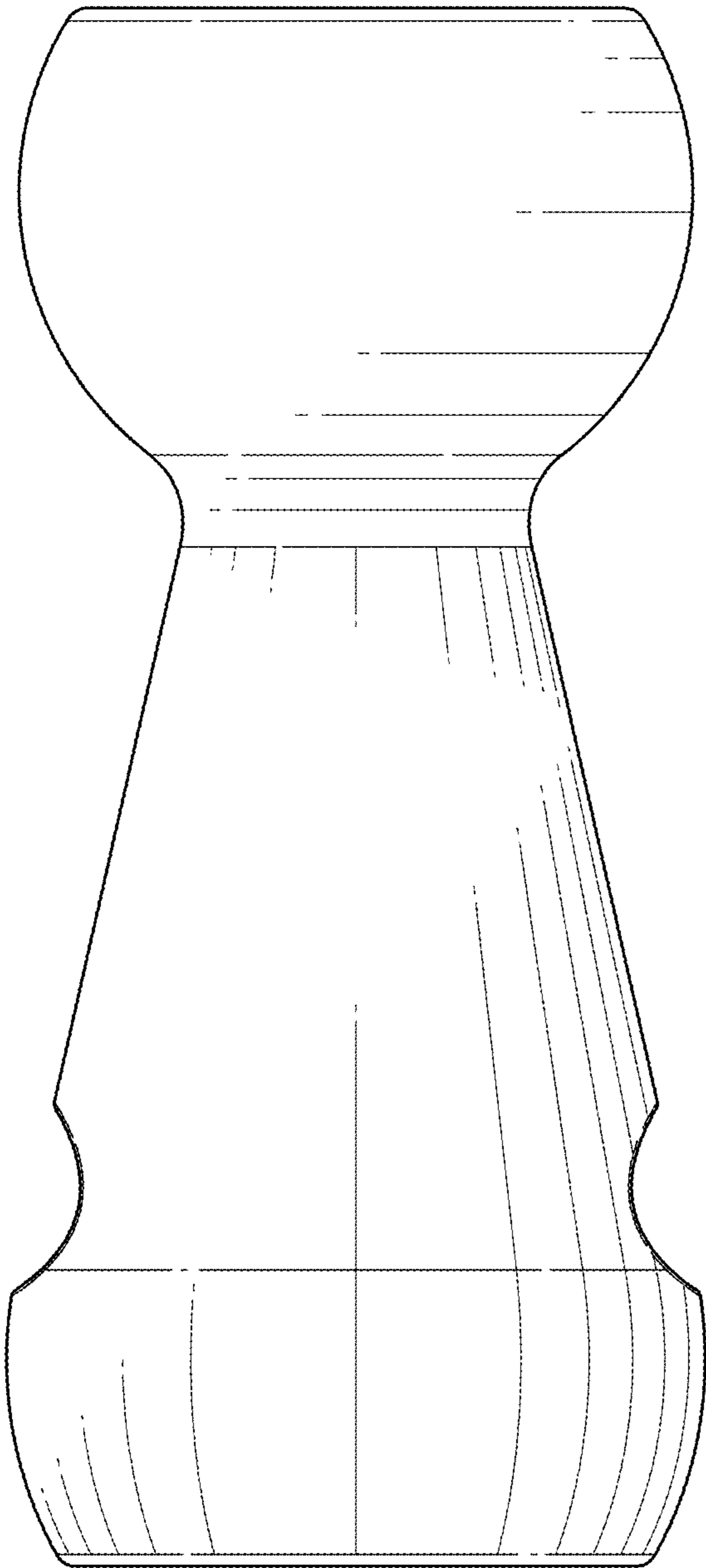

FIG. 22

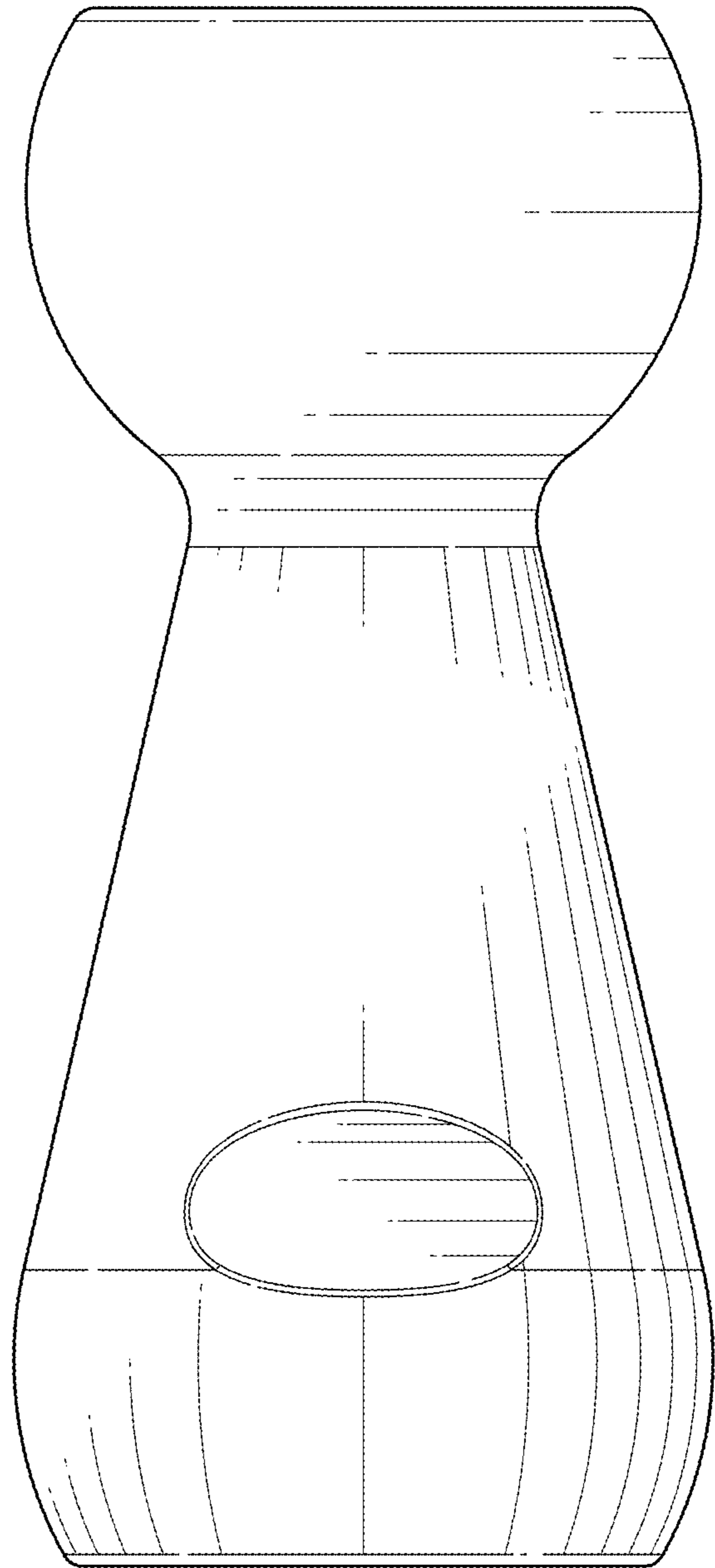

FIG. 23

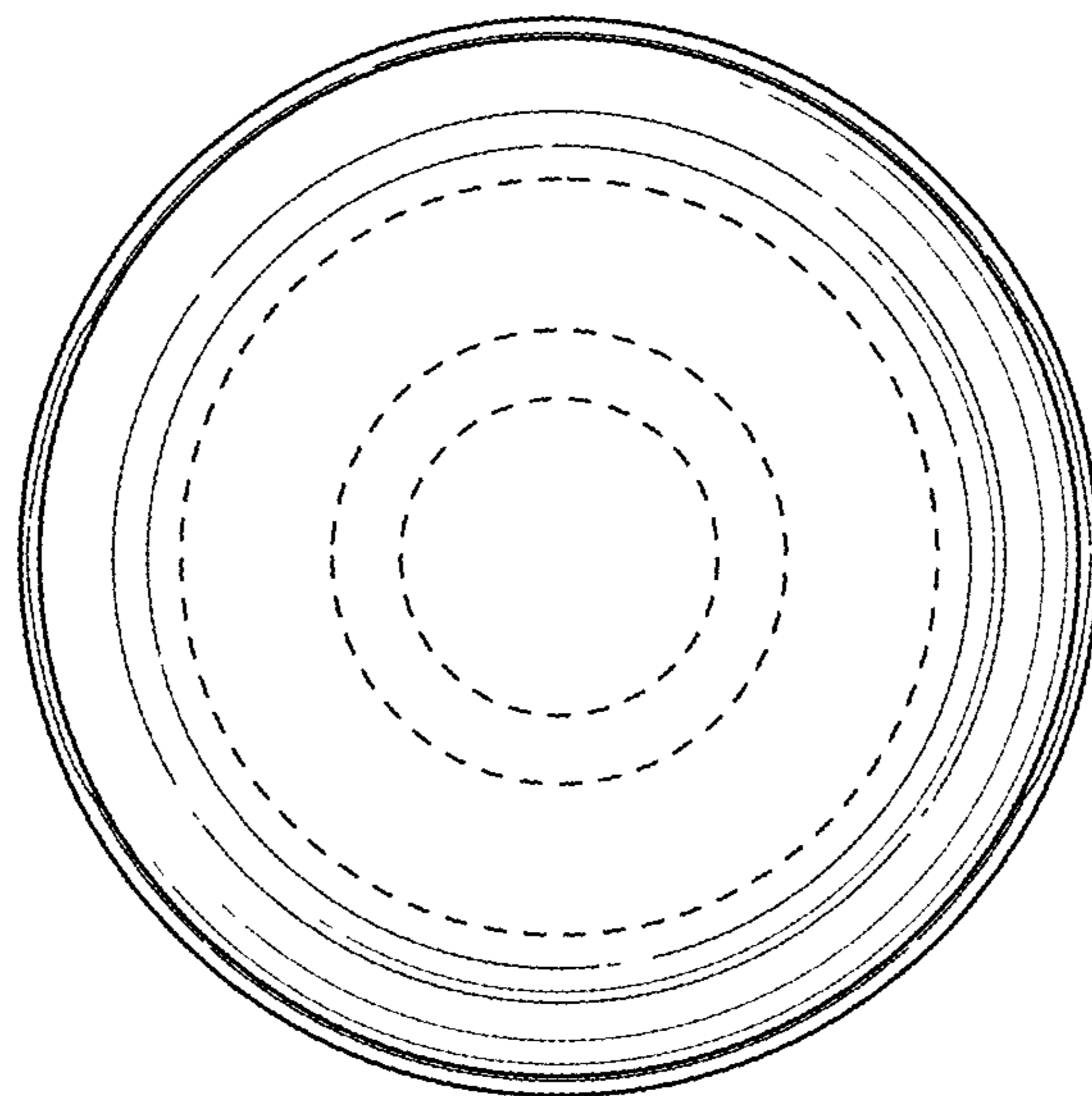

FIG. 24

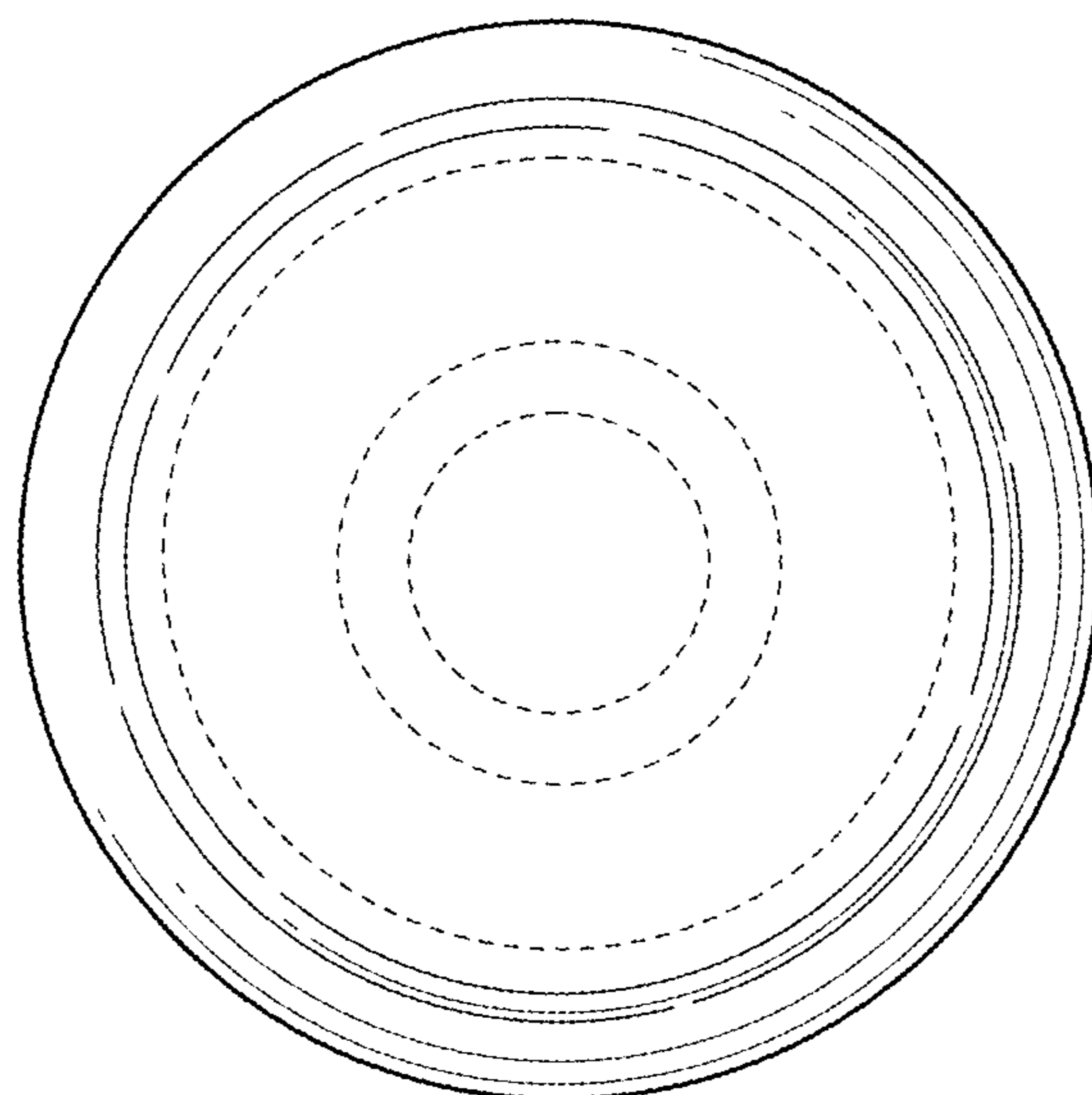

FIG. 25

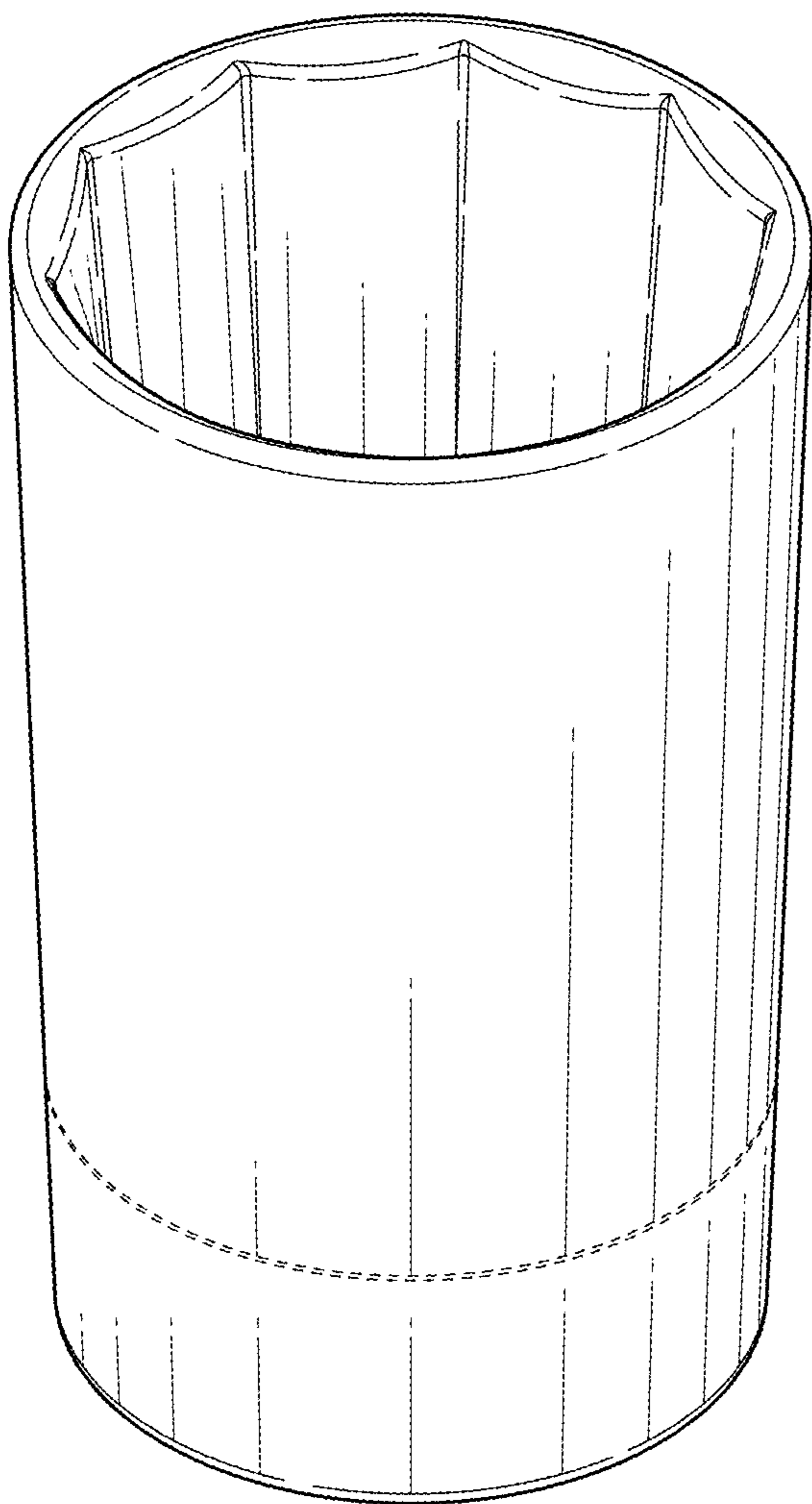

FIG. 26

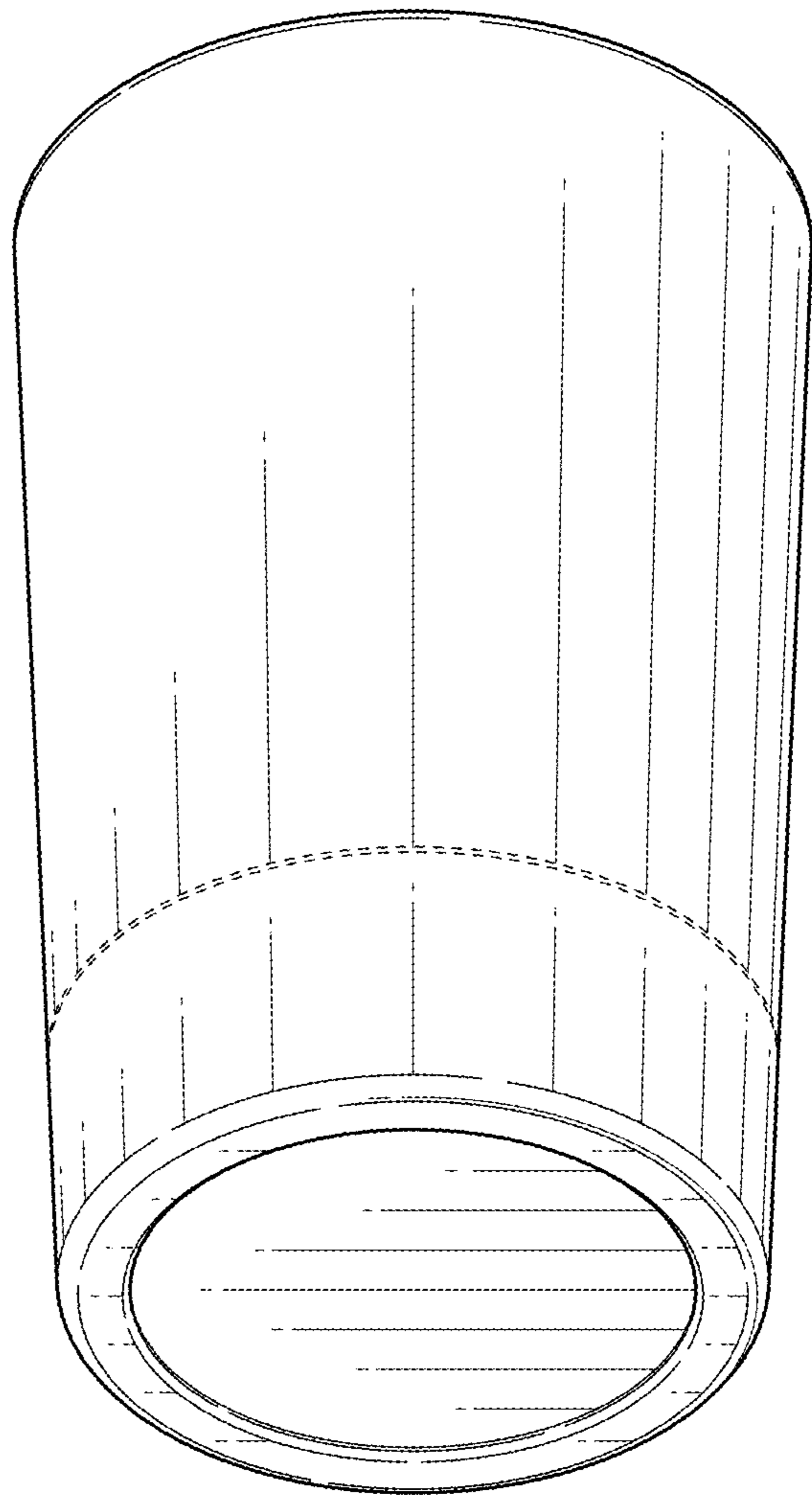

FIG. 27

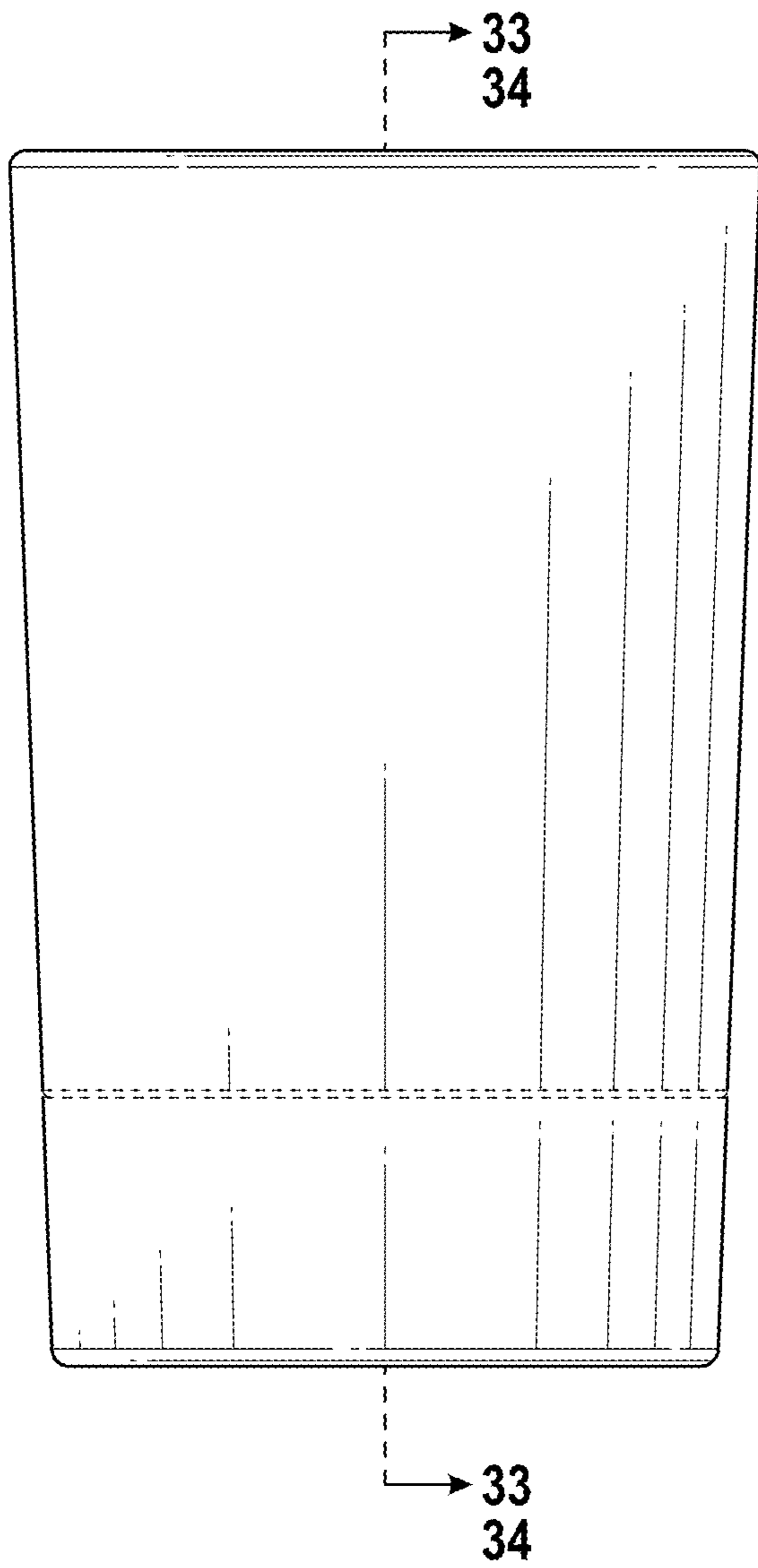

FIG. 28

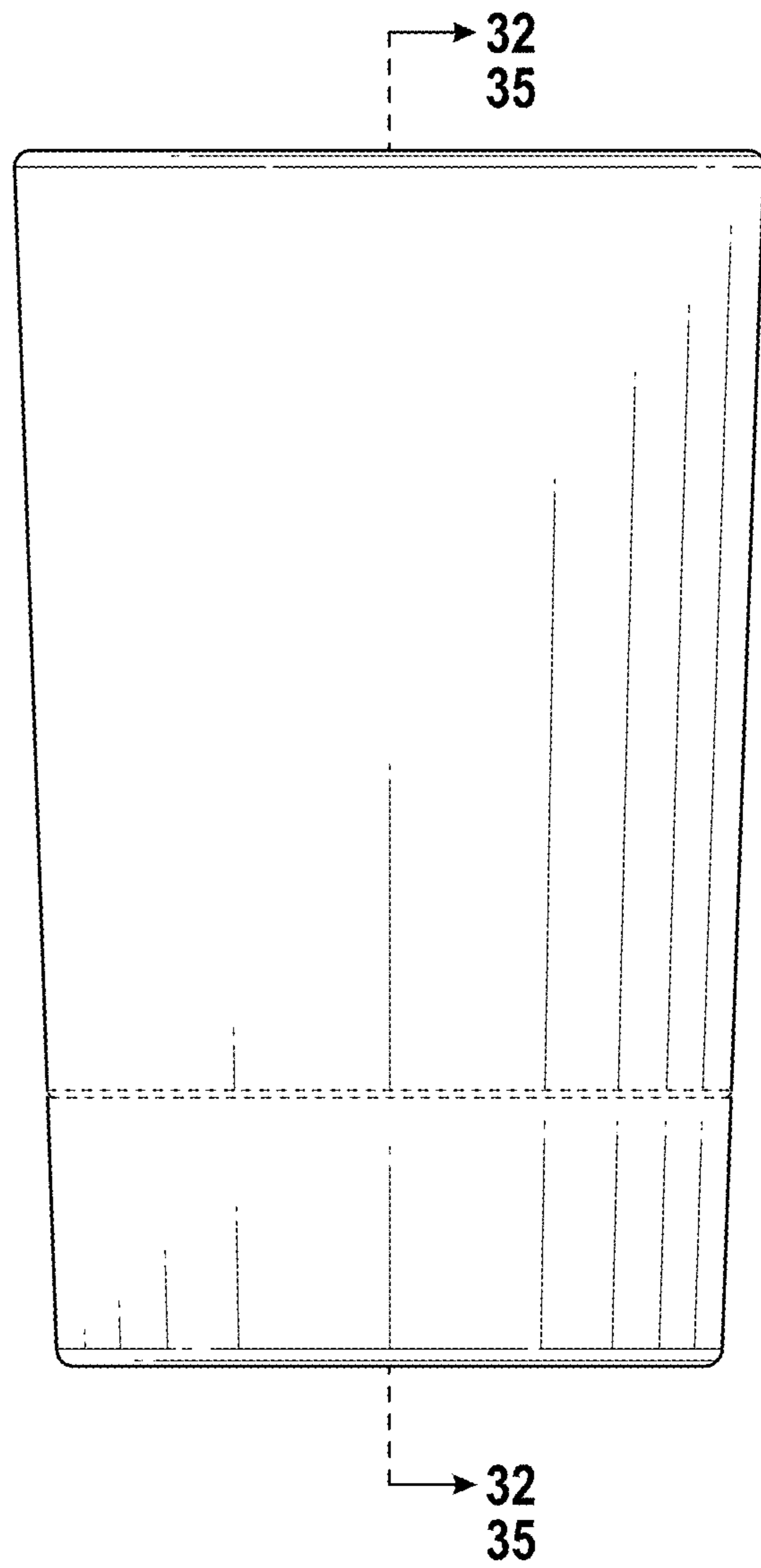

FIG. 29

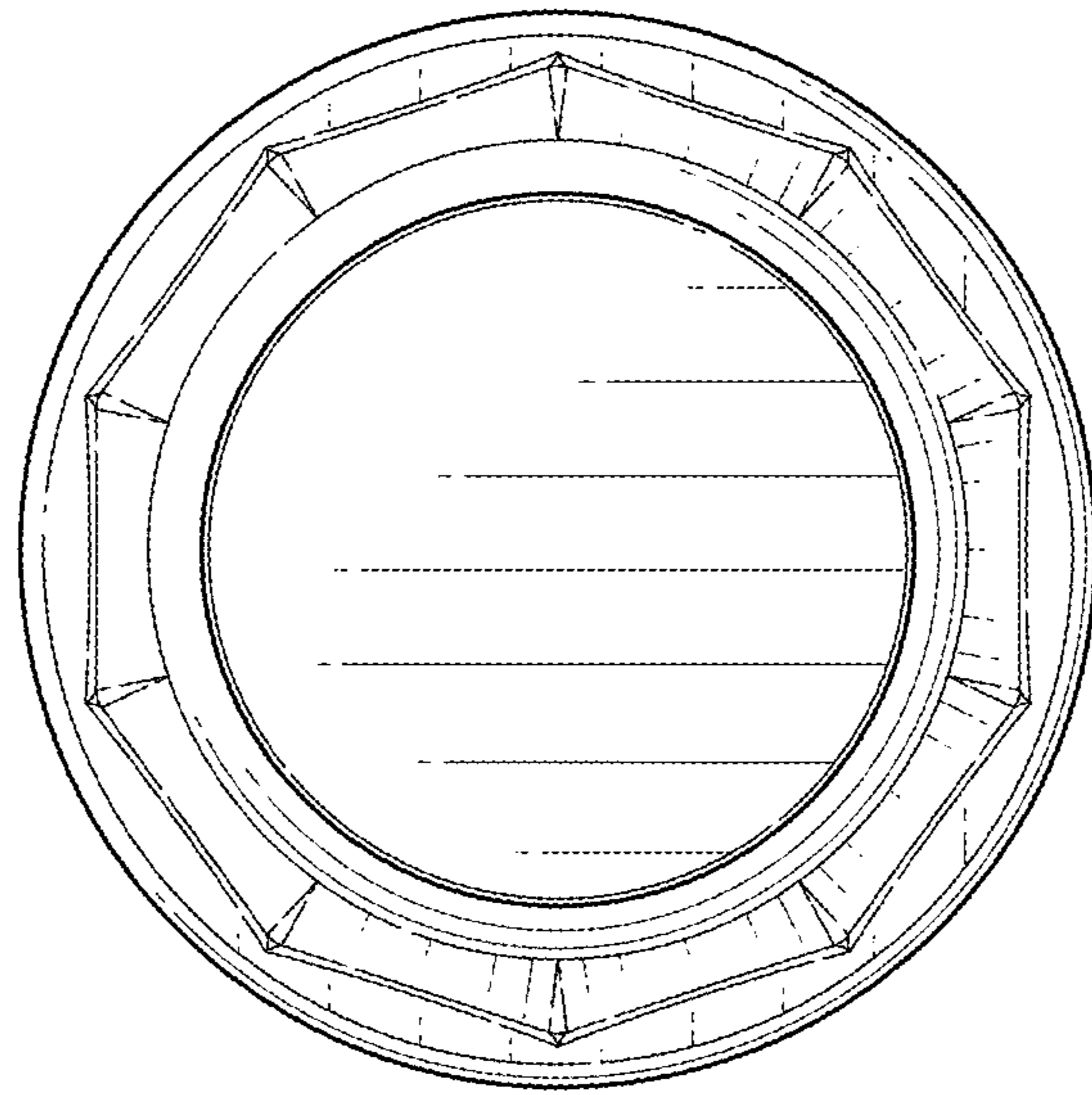

FIG. 30

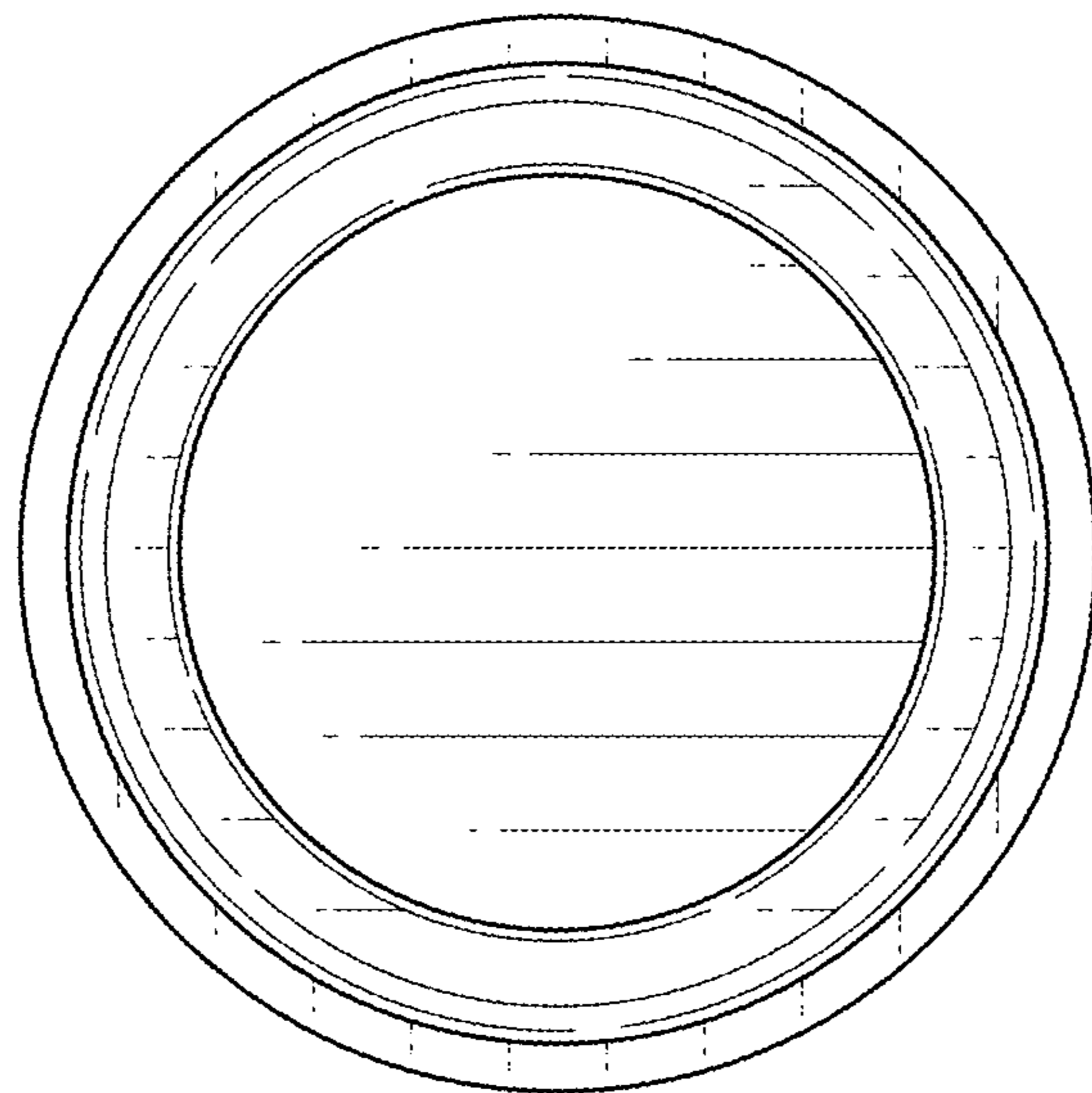

FIG. 31

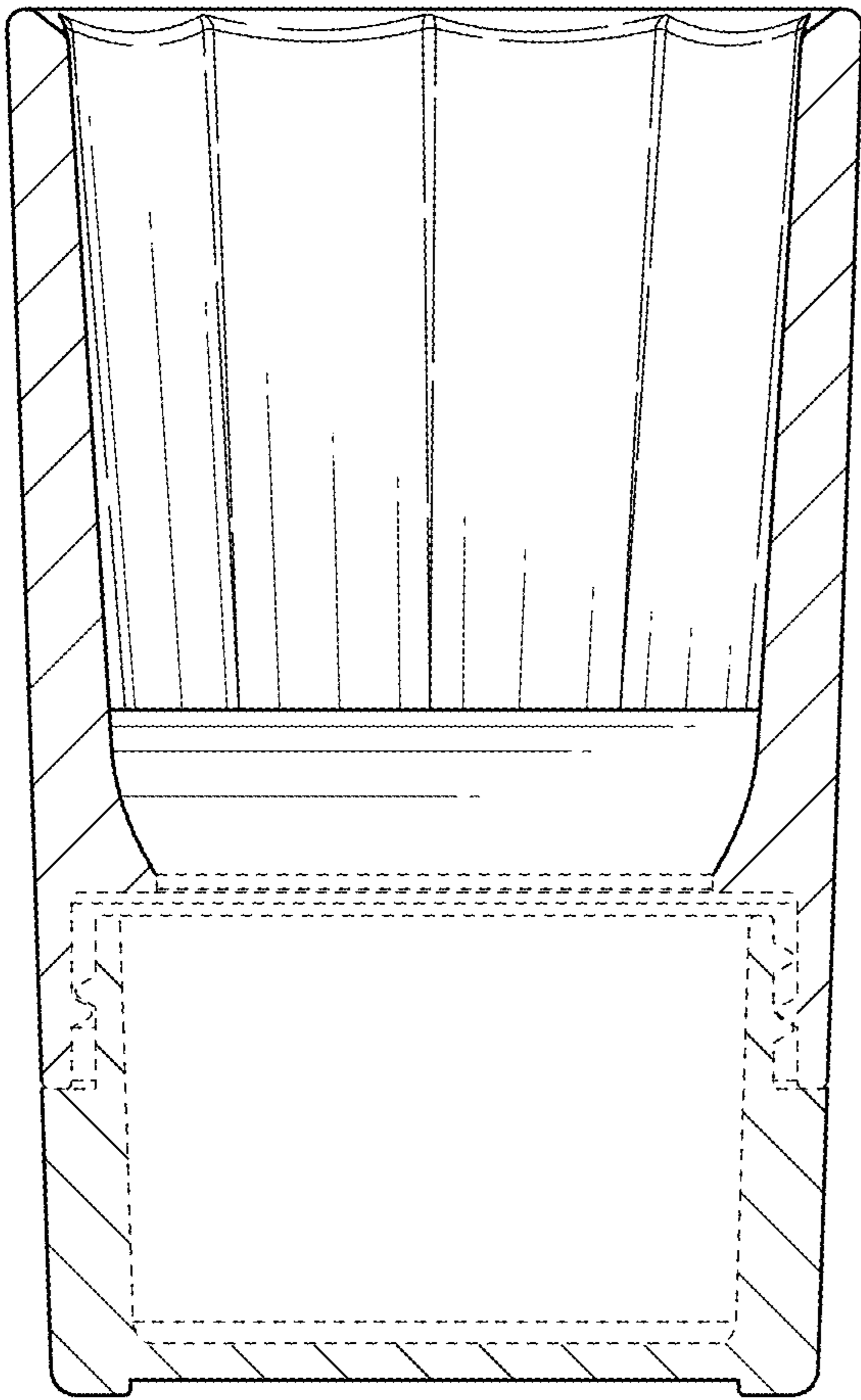

FIG. 32

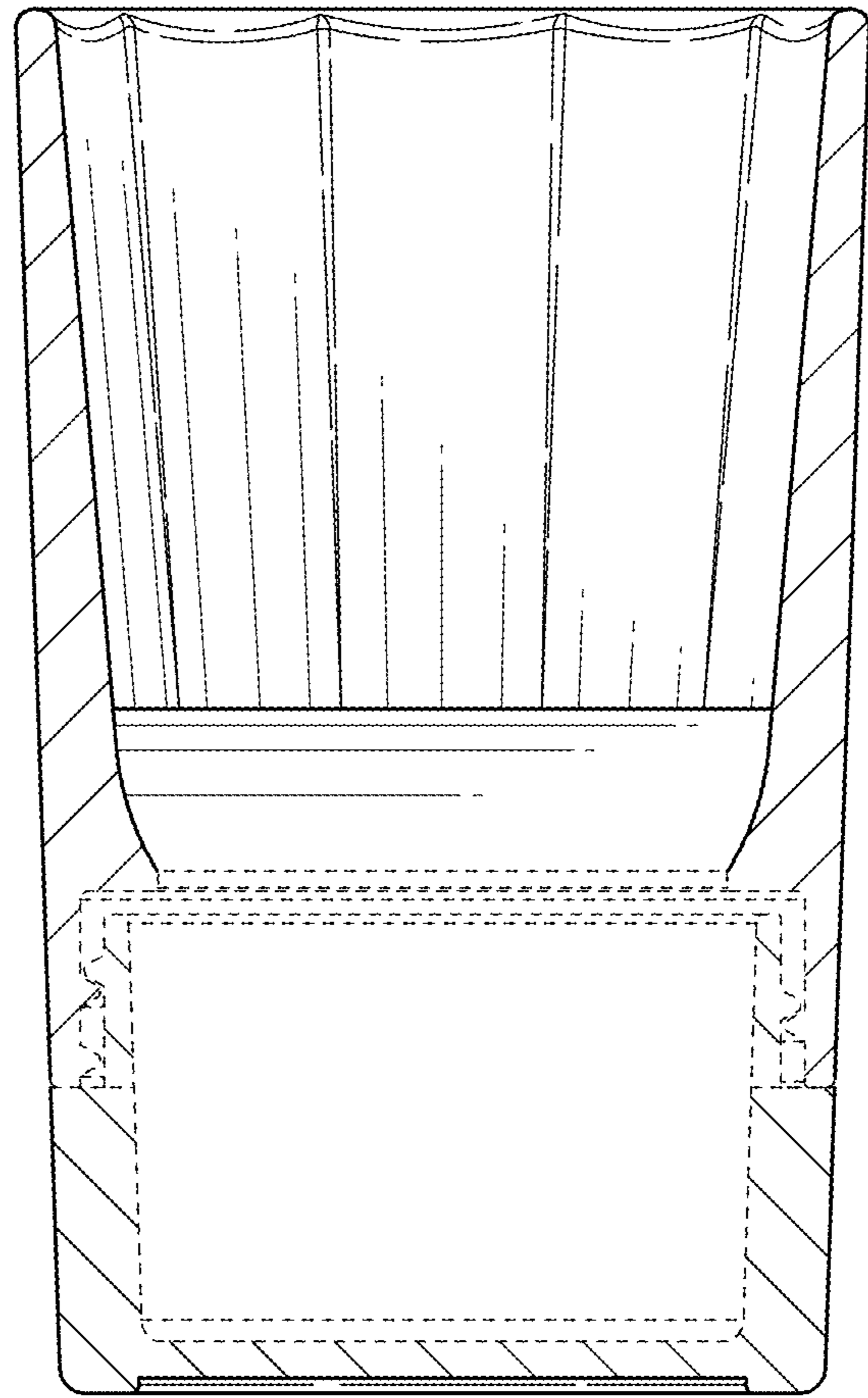

FIG. 33

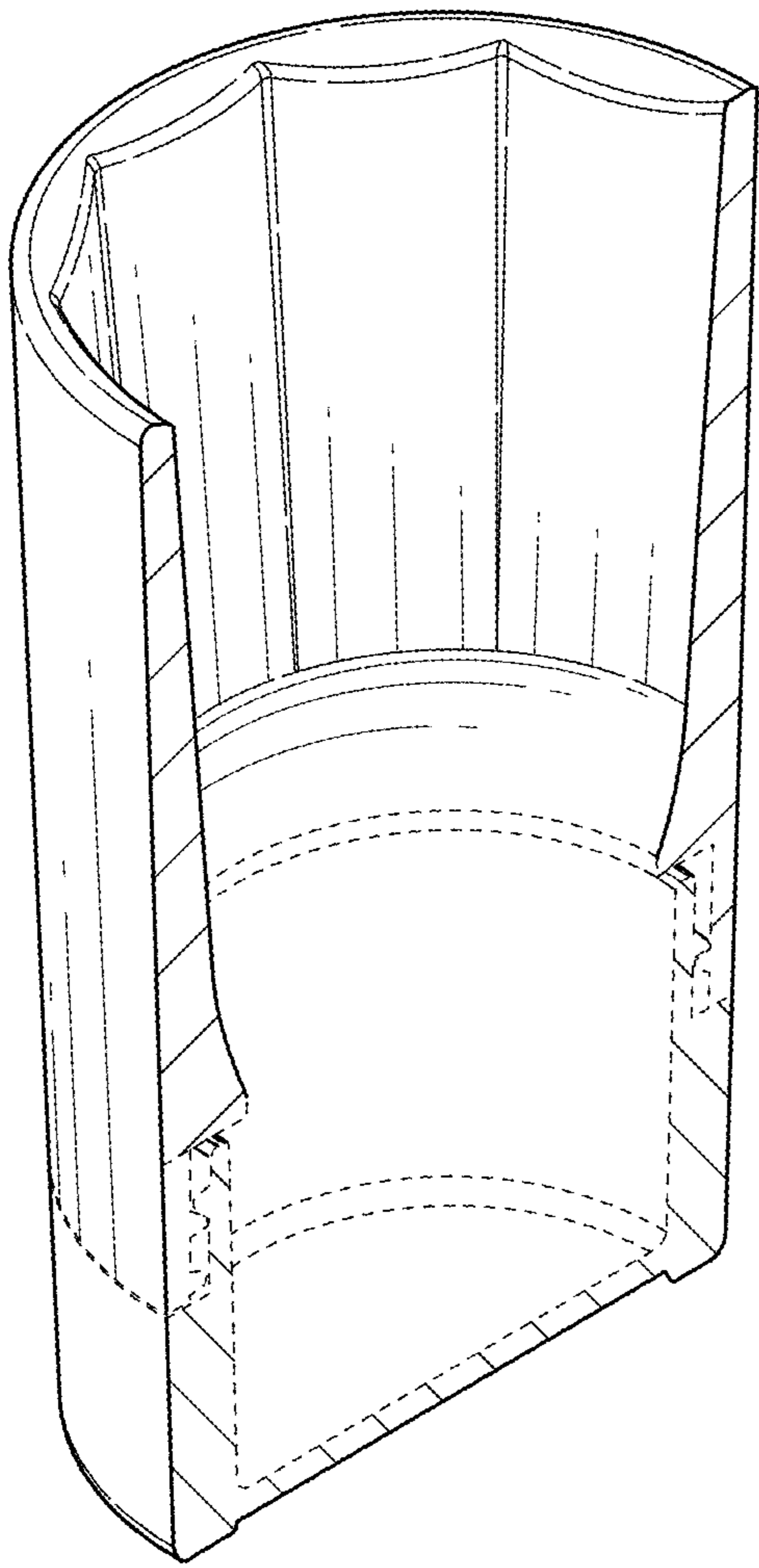

FIG. 34

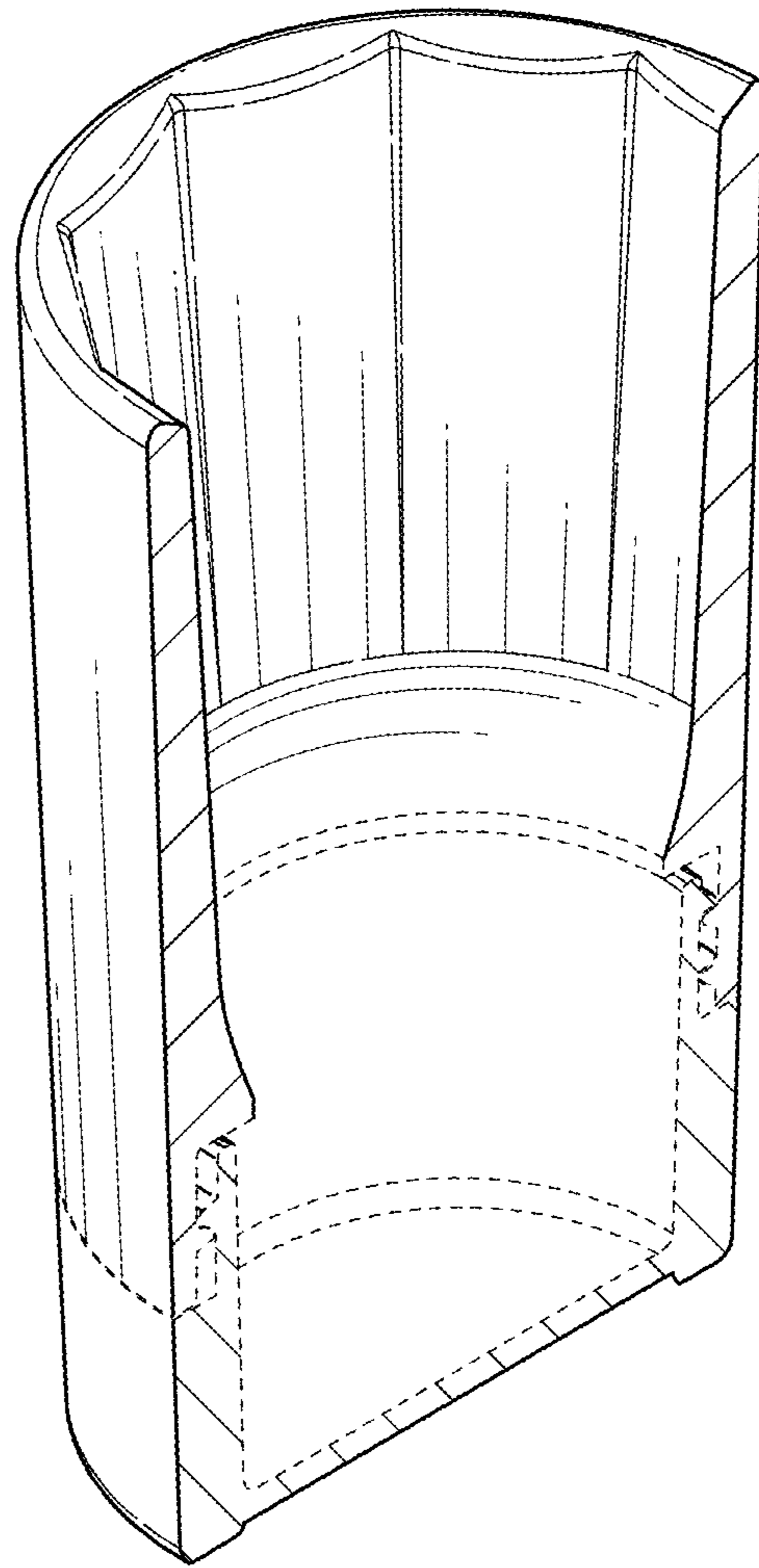

FIG. 35