



US00D984513S

(12) **United States Design Patent**
Huang et al.

(10) **Patent No.:** **US D984,513 S**
(45) **Date of Patent:** **** Apr. 25, 2023**

(54) **OPTICAL LENS**

- (71) Applicant: **Chun Kuang Optics Corp.**, Hsinchu County (TW)
- (72) Inventors: **Hsin-Chieh Huang**, Hsinchu County (TW); **Sheng-Jung Lin**, Hsinchu County (TW); **Shun-Wen Teng**, Hsinchu County (TW)
- (73) Assignee: **CHUN KUANG OPTICS CORP.**, Hsinchu County (TW)
- (**) Term: **15 Years**
- (21) Appl. No.: **29/753,564**
- (22) Filed: **Sep. 30, 2020**
- (51) **LOC (14) Cl.** **16-01**
- (52) **U.S. Cl.**
USPC **D16/219**
- (58) **Field of Classification Search**
USPC D16/206, 211, 217, 218–219, 220;
D10/46, 104.1, 114.6; D14/195, 228, 506
CPC G03B 7/20; G03B 13/00; G03B 13/06;
G03B 17/00; G03B 17/56; G03B 2217/00
See application file for complete search history.

(56) **References Cited**

U.S. PATENT DOCUMENTS

| | | | | | |
|------------|---|---------|-----------|-------|---------|
| D429,817 S | * | 8/2000 | Banks | | D24/190 |
| D571,036 S | * | 6/2008 | Rashidi | | D26/118 |
| D600,729 S | * | 9/2009 | Takishima | | D16/135 |
| D689,649 S | * | 9/2013 | Popper | | D26/124 |
| D725,818 S | * | 3/2015 | Yao | | D26/118 |
| D841,077 S | * | 2/2019 | Kip | | D16/242 |
| D869,061 S | * | 12/2019 | Altamura | | D26/118 |

FOREIGN PATENT DOCUMENTS

| | | | |
|----|-----------|---|--------|
| CN | 302703905 | * | 1/2014 |
| CN | 306451885 | * | 4/2021 |
| CN | 307570579 | * | 9/2022 |

OTHER PUBLICATIONS

- “Narrow Beam 3 Degree Led Lens” from Tradeindia.com, first retrieved Jan. 23, 2023 from the internet <<https://www.tradeindia.com/products/narrow-beam-3-degree-led-lens-4585567.html>> (Year: 2023).*
- “Uxcell Clear High Power LED Lens Reflector Collimator 5 Degree 20mm 10pcs” from Amazon.com, first available May 29, 2015 from the internet <<https://www.amazon.com/uxcell-Clear-Reflector-Collimator-Degree/dp/B00YGBKA40/>> (Year: 2015).*
- “Single Lenses for Power LEDs—Narrow Beam—Color Mixing” from Khatod.com, first retrieved Jan. 23, 2023 from the internet <<https://www.khatod.com/en/product-3009/Single-Lenses-for-Power-LEDs---Narrow-Beam---Color-Mixing.html?lang=EN&ProdTypePrg=61&AserPrg=779>> (Year: 2023).*

* cited by examiner

Primary Examiner — Elizabeth J Oswecki

Assistant Examiner — Lacey Chey Bowman

(74) *Attorney, Agent, or Firm* — Chun-Ming Shih; HDLS IPR Services

(57) **CLAIM**

The ornamental design for an optical lens, as shown and described.

DESCRIPTION

FIG. 1 is a perspective view of an optical lens showing our new design;
 FIG. 2 is a front view thereof;
 FIG. 3 is a rear view thereof;
 FIG. 4 is a left side view thereof;
 FIG. 5 is a right side view thereof;
 FIG. 6 is a top view thereof;
 FIG. 7 is a bottom view thereof;
 FIG. 8 is second perspective view thereof;
 FIG. 9 is a cross sectional view taken along line 9-9 in FIG. 2; and,
 FIG. 10 is a cross sectional view taken along line 10-10 in FIG. 2.

1 Claim, 10 Drawing Sheets

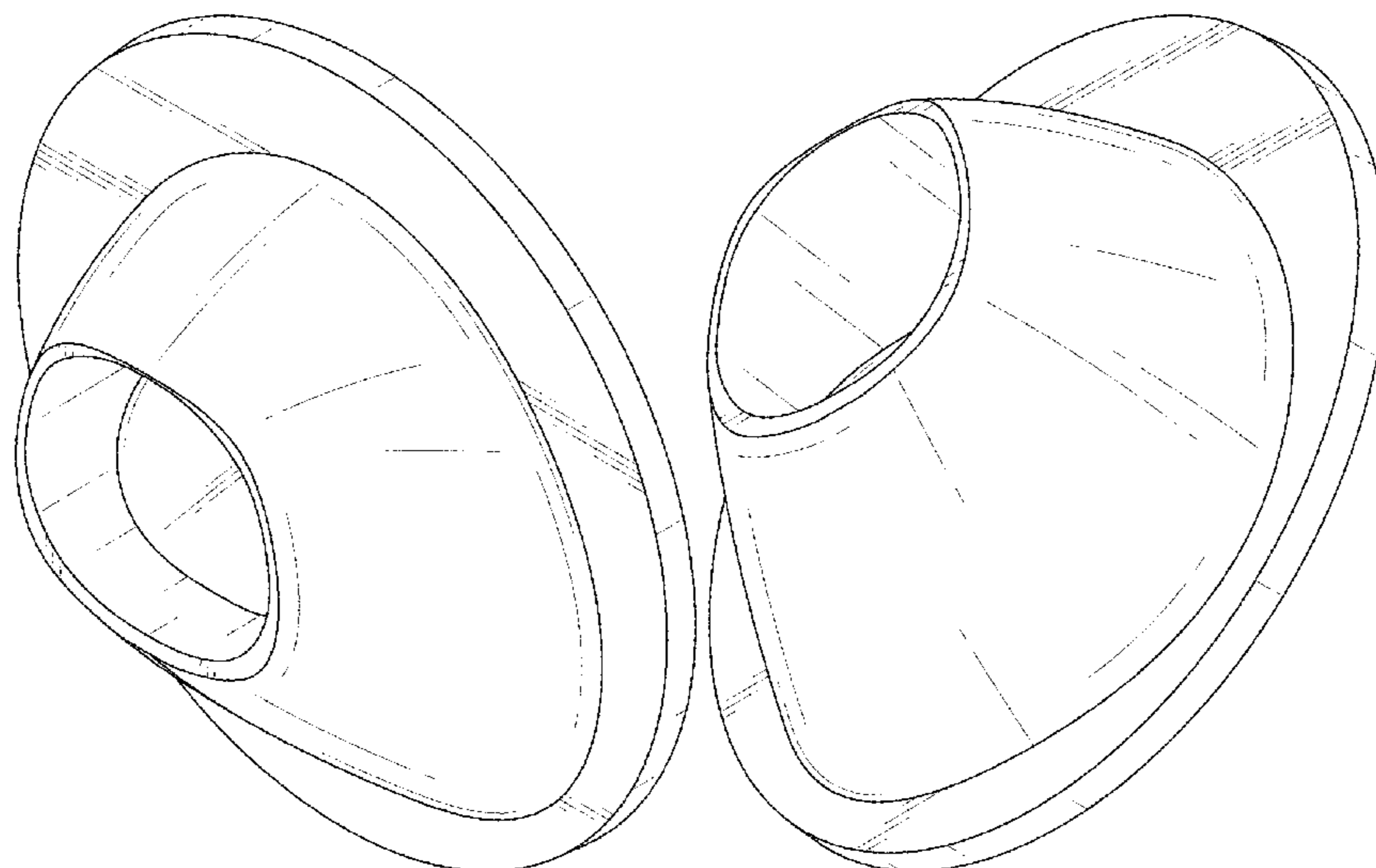

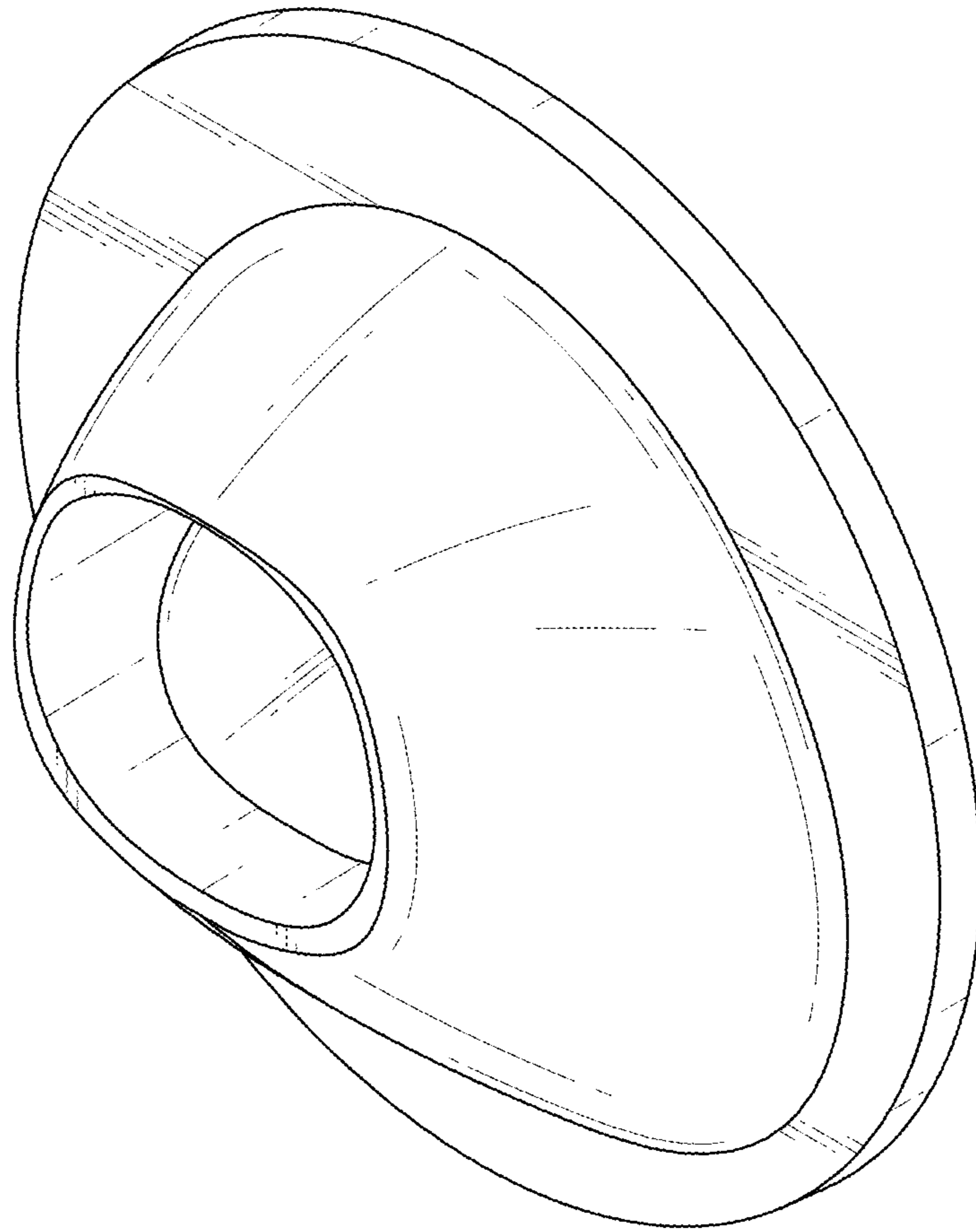

FIG.1

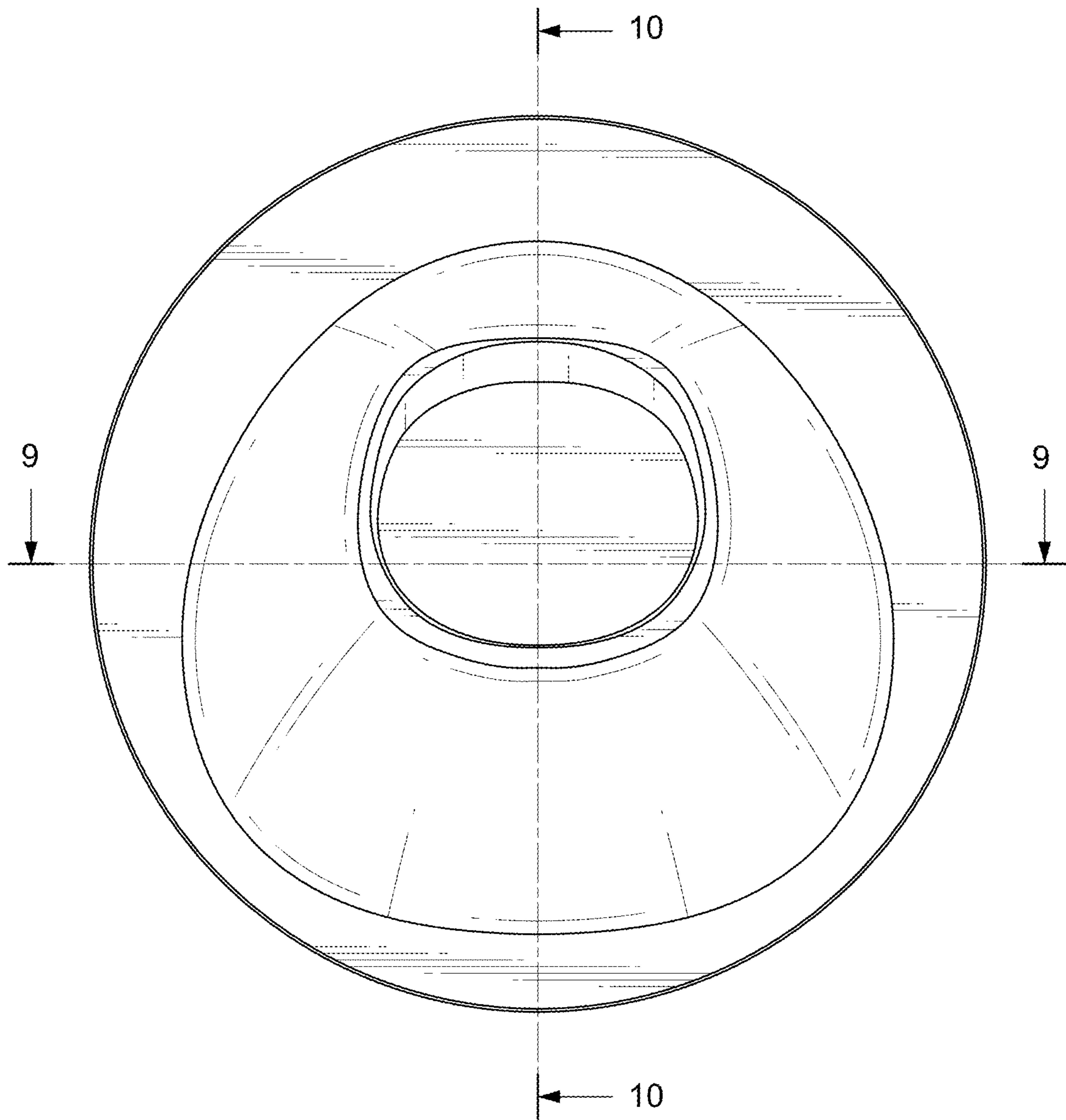

FIG.2

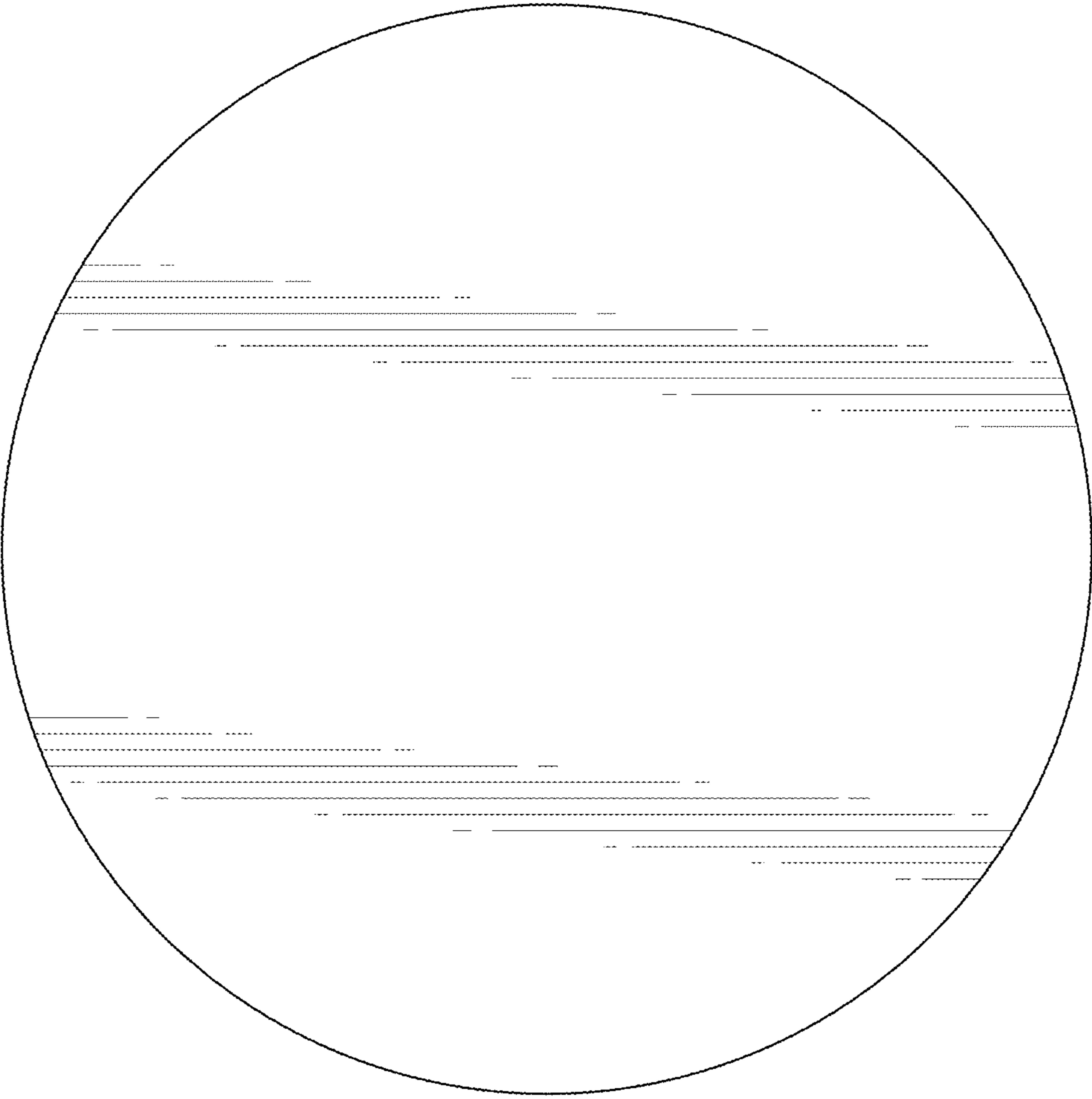

FIG.3

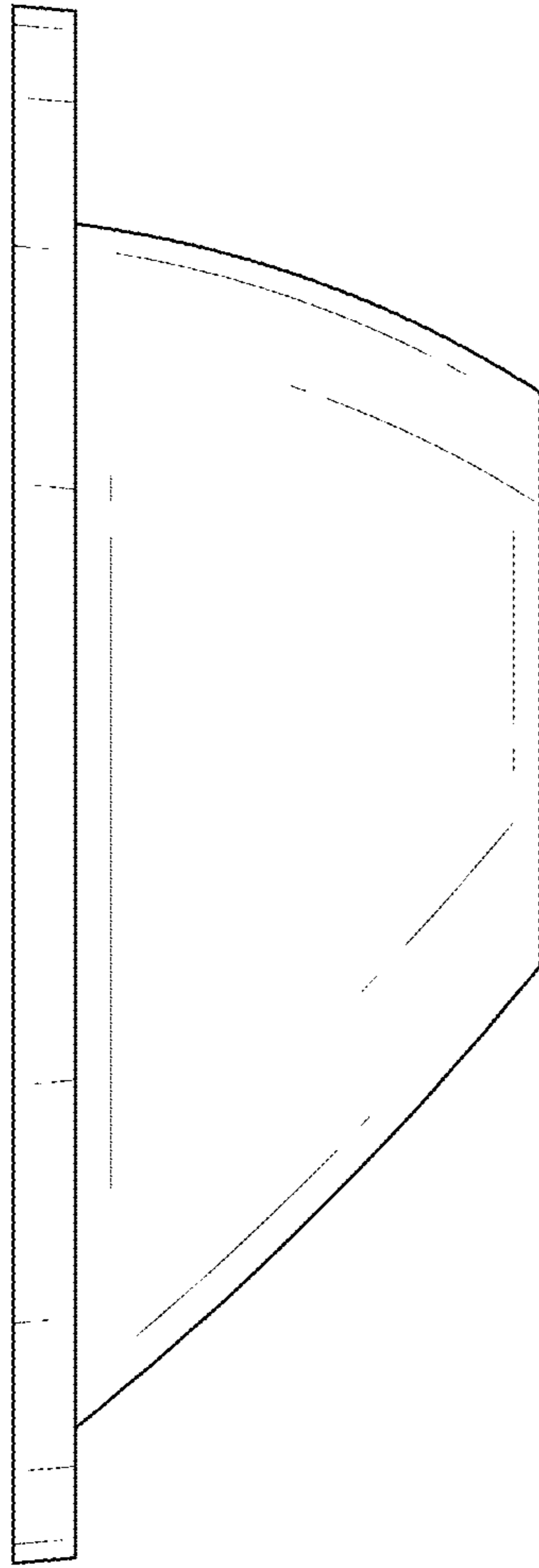

FIG.4

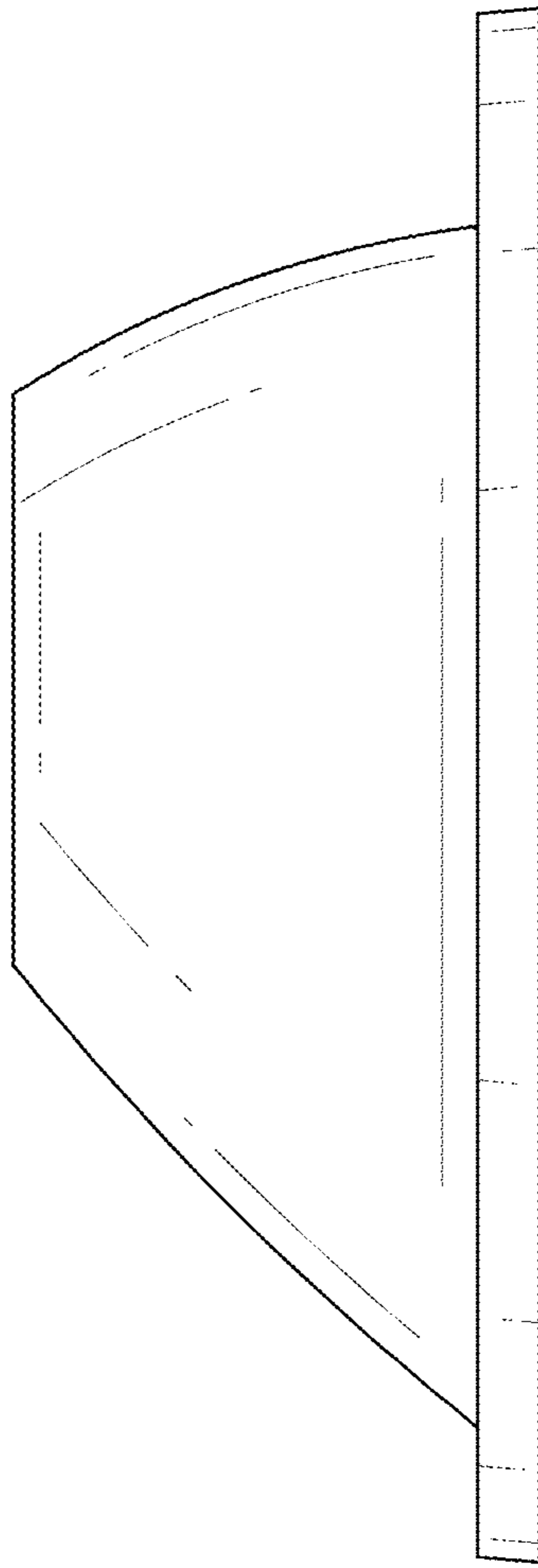

FIG.5

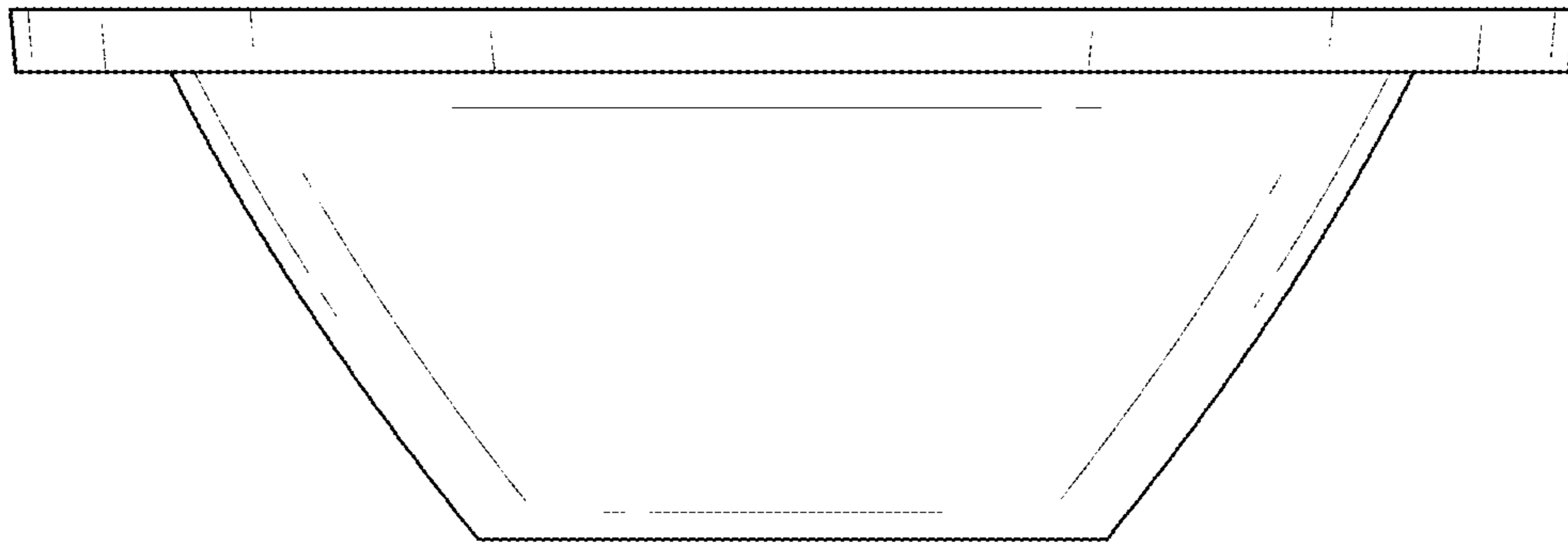

FIG.6

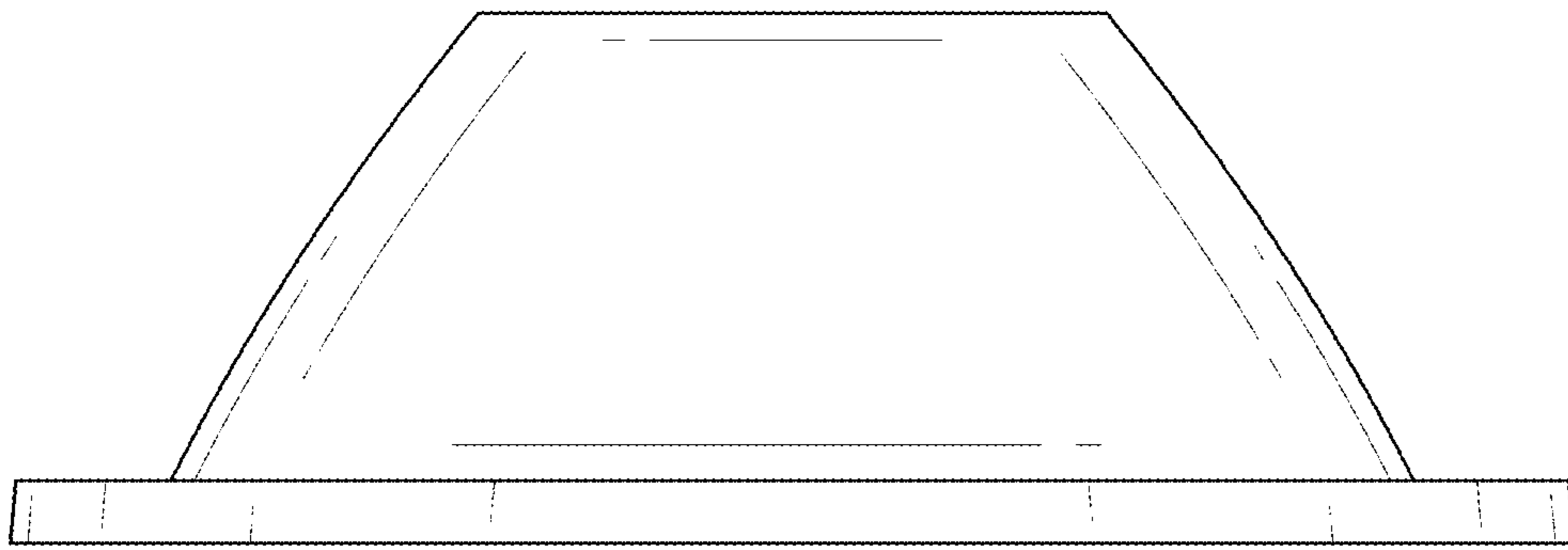

FIG.7

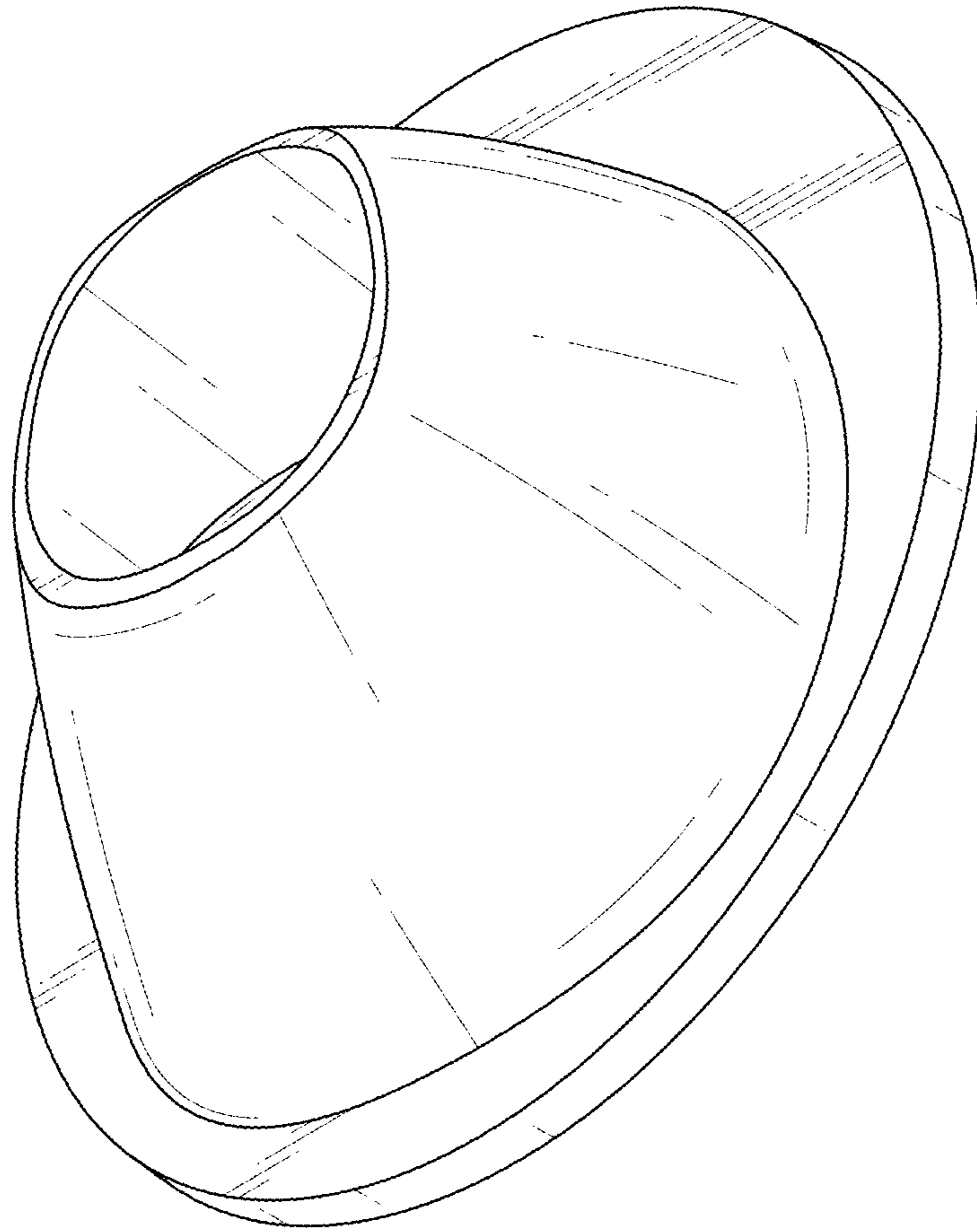

FIG.8

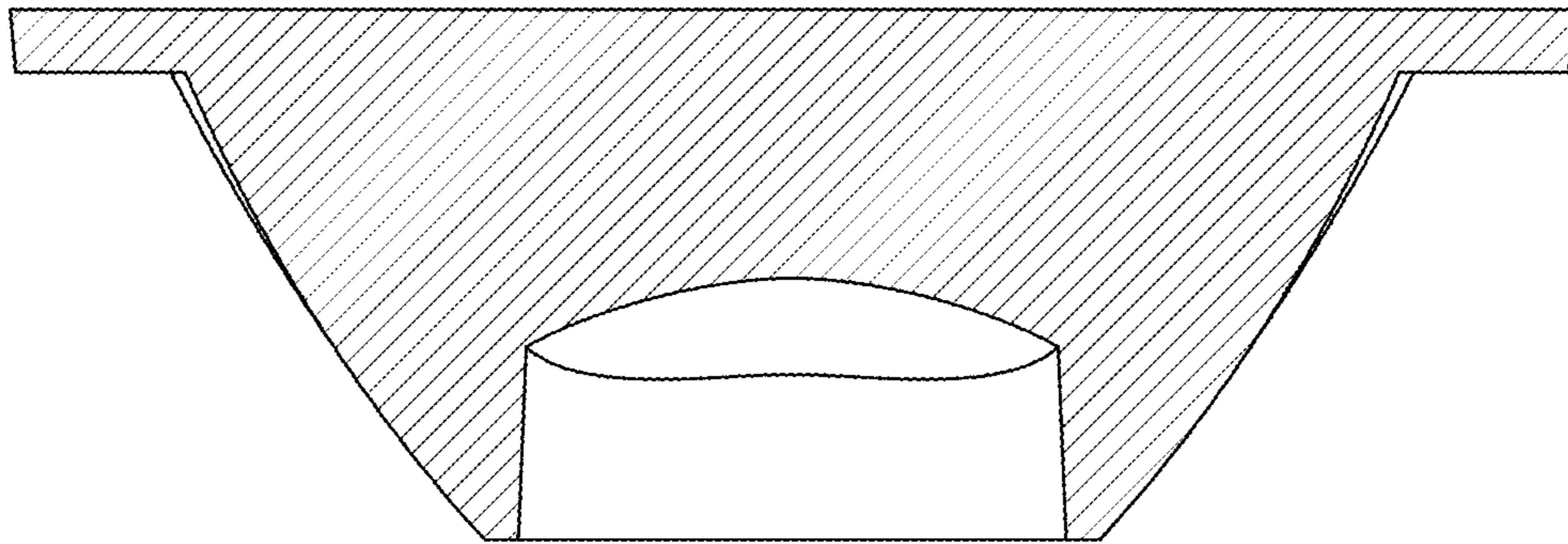

FIG.9

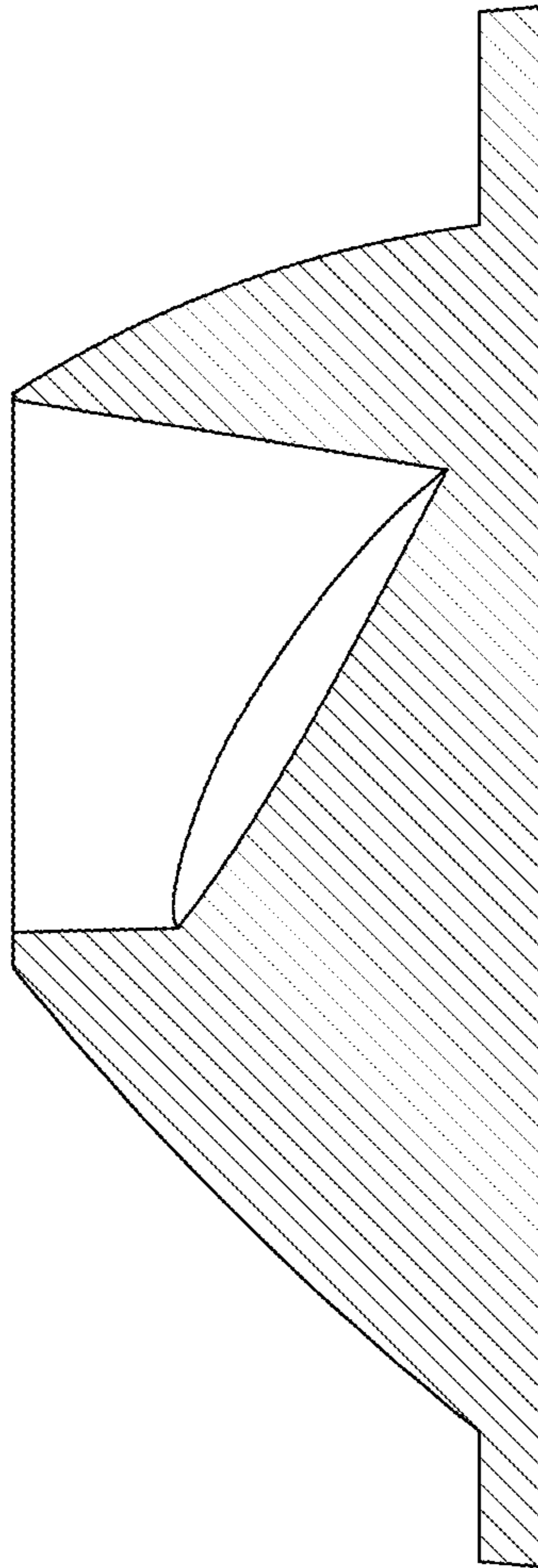

FIG.10