



US00D984505S

(12) **United States Design Patent**
Choi et al.

(10) **Patent No.:** **US D984,505 S**
(45) **Date of Patent:** **** Apr. 25, 2023**

(54) **CARGO CONTAINER WITH ILLUMINATED INDICATOR**

DESCRIPTION

(71) Applicant: **DEKA Products Limited Partnership**,
Manchester, NH (US)

(72) Inventors: **Sooshin Choi**, Londonderry, NH (US);
Spencer Winfield Trafton, Nashua, NH
(US)

(73) Assignee: **FedEx Corporation**, Memphis, TN
(US)

(**) Term: **15 Years**

(21) Appl. No.: **29/725,486**

(22) Filed: **Feb. 25, 2020**

(51) **LOC (14) Cl.** **15-99**

(52) **U.S. Cl.**
USPC **D15/199**; D3/272; D12/415

(58) **Field of Classification Search**
USPC D3/201, 273, 232, 287, 276, 272, 215,
D3/282, 217, 225, 218, 226, 274;
(Continued)

(56) **References Cited**

U.S. PATENT DOCUMENTS

D257,358 S * 10/1980 Armbruster D16/131
D260,252 S 8/1981 Groene
(Continued)

Primary Examiner — Patricia A Palasik

(74) *Attorney, Agent, or Firm* — Finnegan, Henderson,
Farabow, Garrett & Dunner LLP

(57) **CLAIM**

The ornamental design for a cargo container with illuminated indicator, as shown and described.

FIG. 1 is a front, top, and right side perspective view of the cargo container with illuminated indicator, showing the new design;

FIG. 2 is a front elevational view thereof;

FIG. 3 is a rear elevational view thereof;

FIG. 4 is a left elevational view thereof;

FIG. 5 is a right elevational view thereof;

FIG. 6 is a top plan view thereof;

FIG. 7 is another front, top, and right side perspective view of the cargo container with illuminated indicator, showing the new design;

FIG. 8 is a front elevational view thereof;

FIG. 9 is a rear elevational view thereof;

FIG. 10 is a left elevational view thereof;

FIG. 11 is a right elevational view thereof;

FIG. 12 is a top plan view thereof;

FIG. 13 is another front, top, and right side perspective view of the Cargo container with illuminated indicator, showing the new design;

FIG. 14 is a front elevational view thereof;

FIG. 15 is a rear elevational view thereof;

FIG. 16 is a left elevational view thereof;

FIG. 17 is a right elevational view thereof; and,

FIG. 18 is a top plan view thereof.

No portion of the claimed design is visible from a bottom plan view of the cargo container with illuminated indicator.

The ornamental design which is claimed is shown in solid lines in the drawings. Any broken lines in the drawings illustrate portions of the cargo container with illuminated indicator which form no part of the claimed design.

Areas of the design that appear shaded with different shades of gray represent illuminated areas. Intensity of illumination increases as the shade of gray increases in darkness.

The subject matter in this disclosure includes a process or period in which the area of illumination of the indicator changes from one region (FIGS. 1-6) of the indicator of the cargo container with illuminated indicator to other regions (FIGS. 7-13 and FIGS. 14-18) of the indicator. The process or period forms no part of the claimed design.

1 Claim, 18 Drawing Sheets

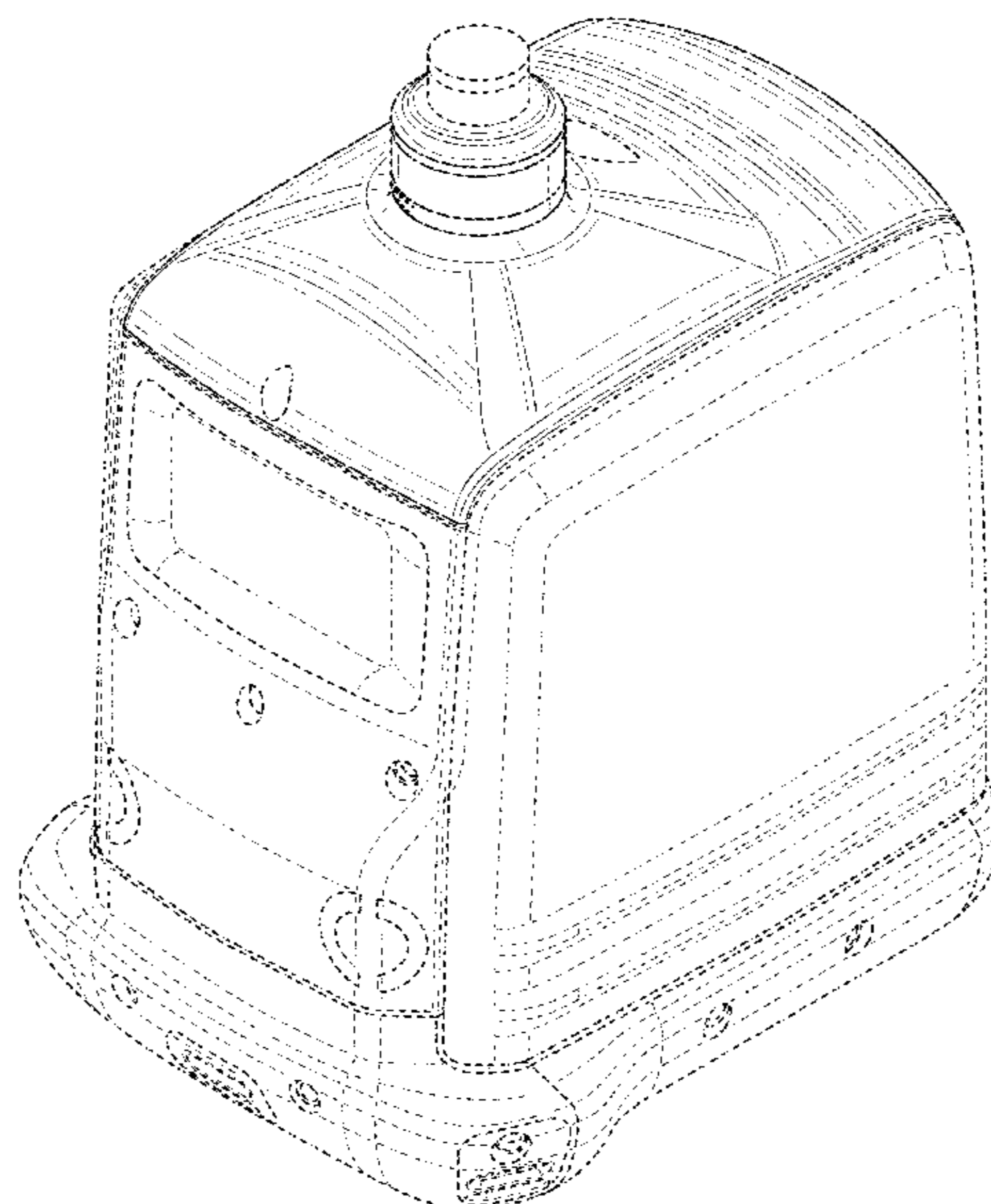

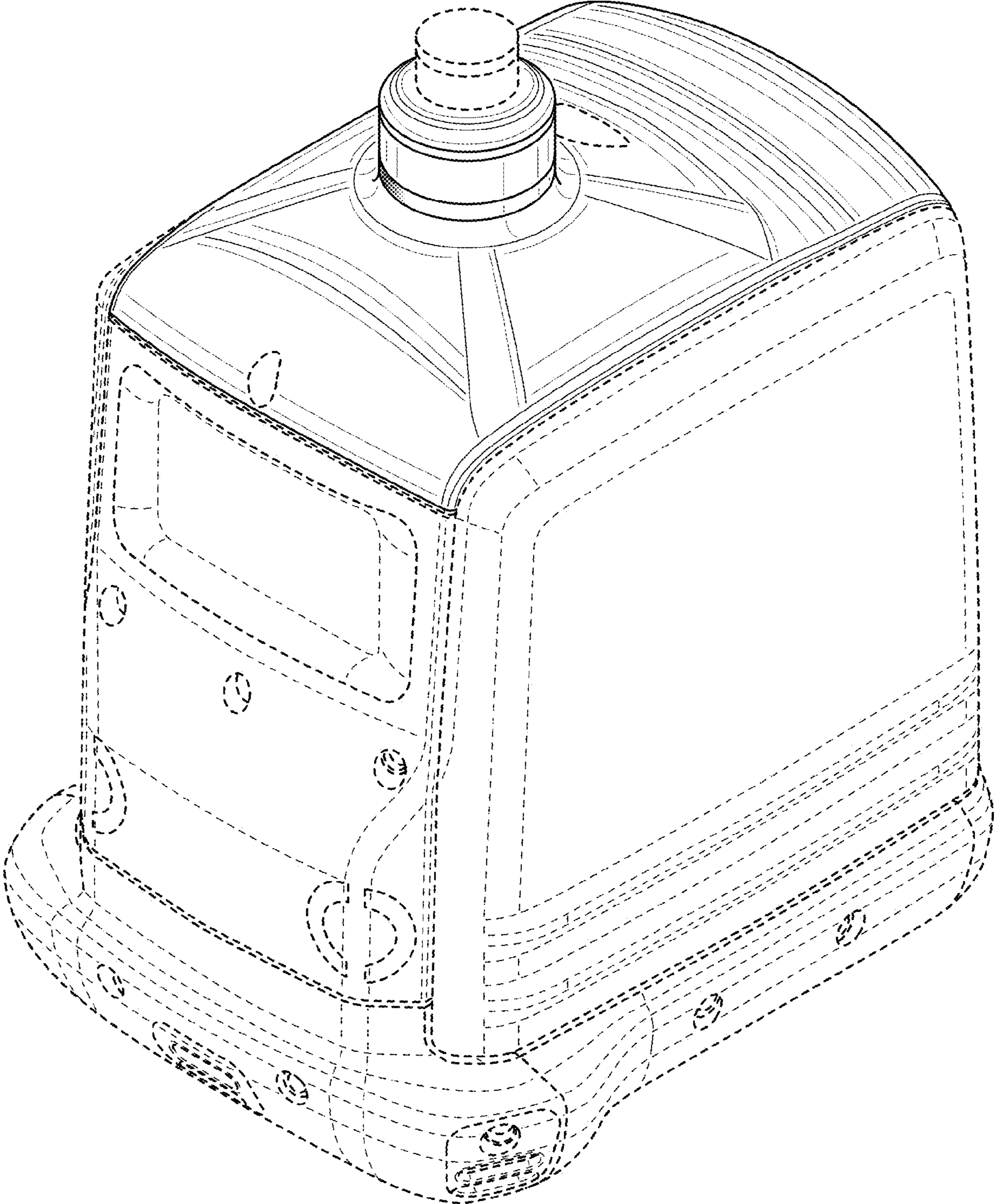

FIG. 1

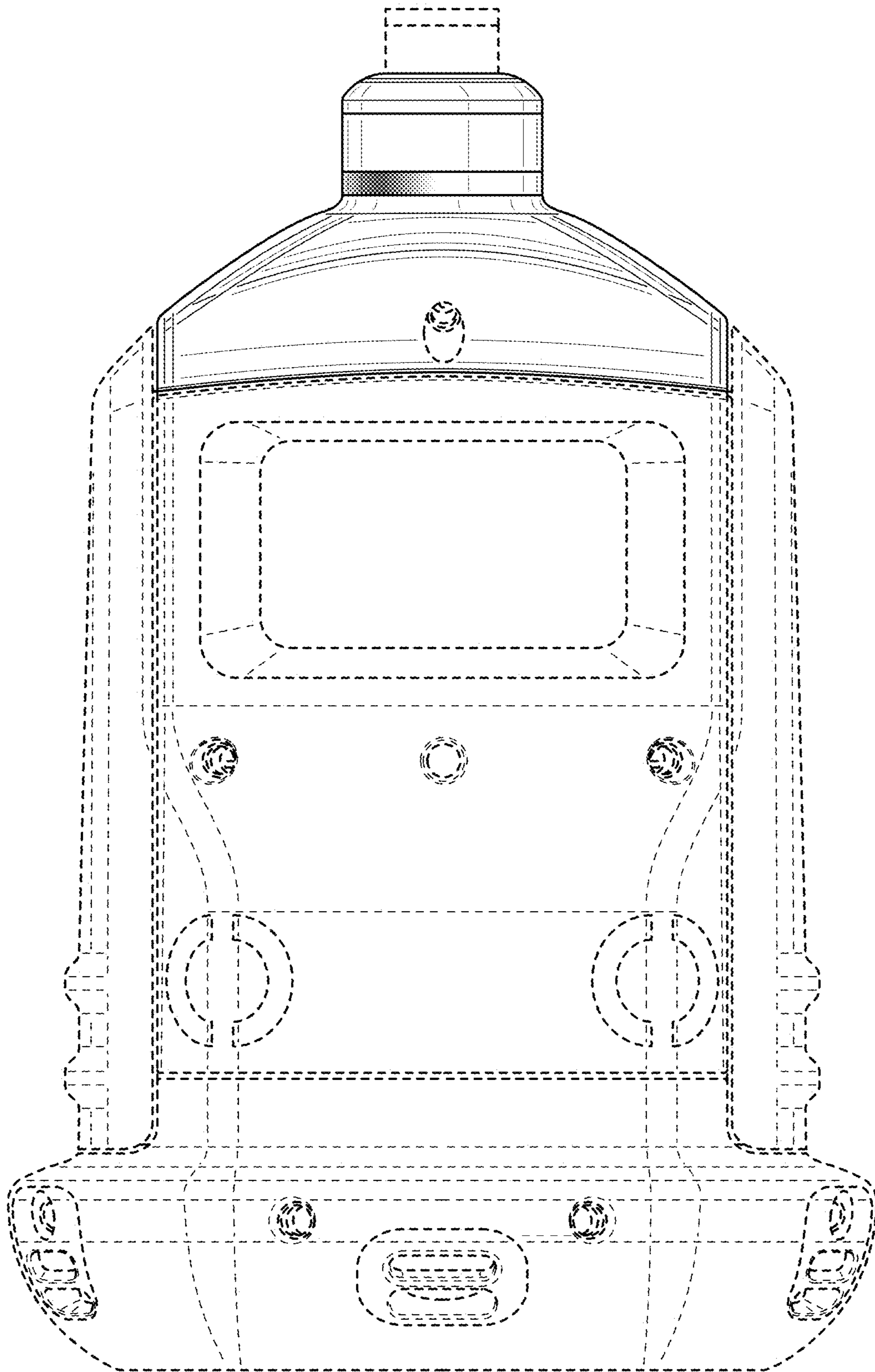

FIG. 2

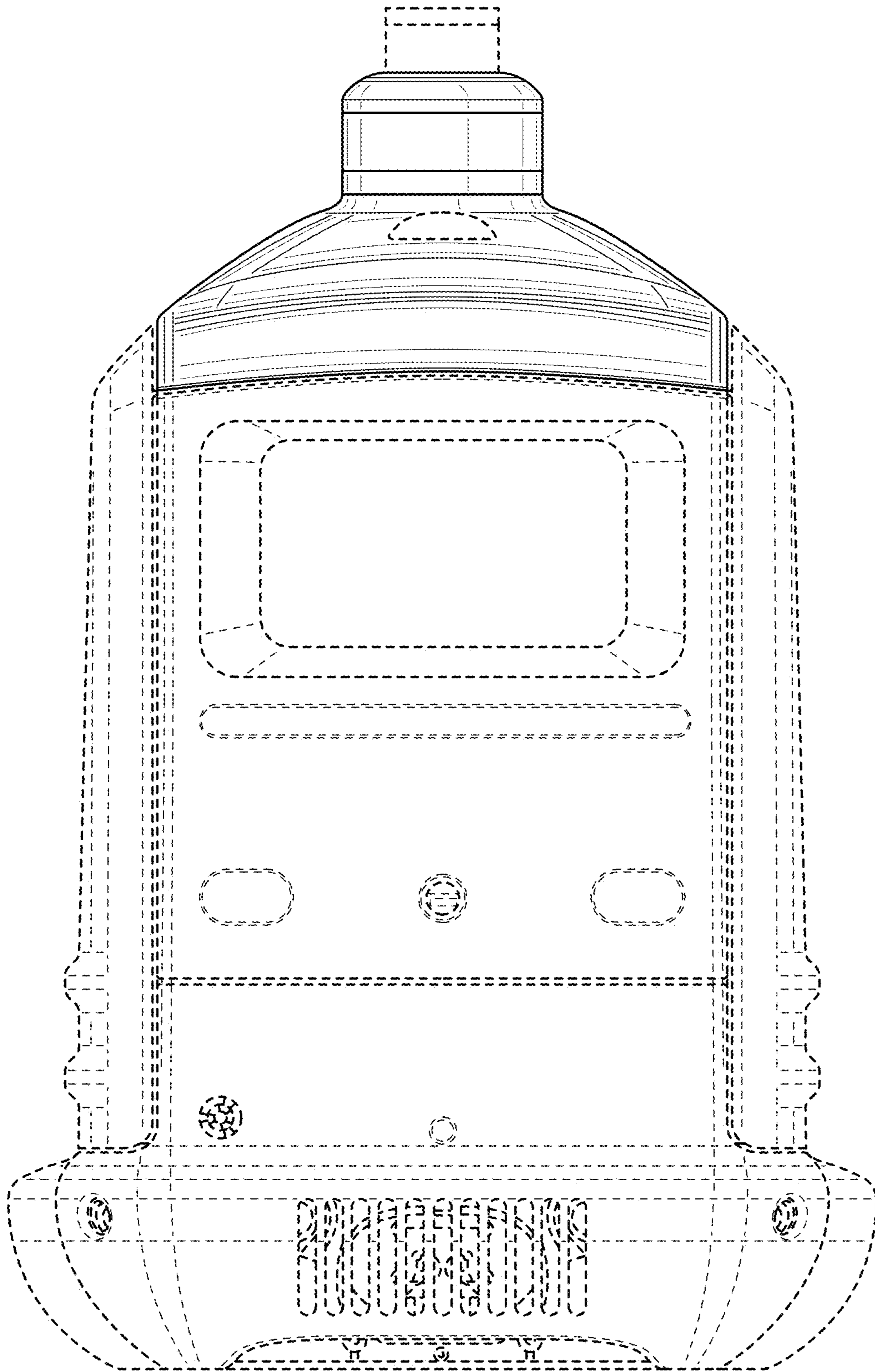

FIG. 3

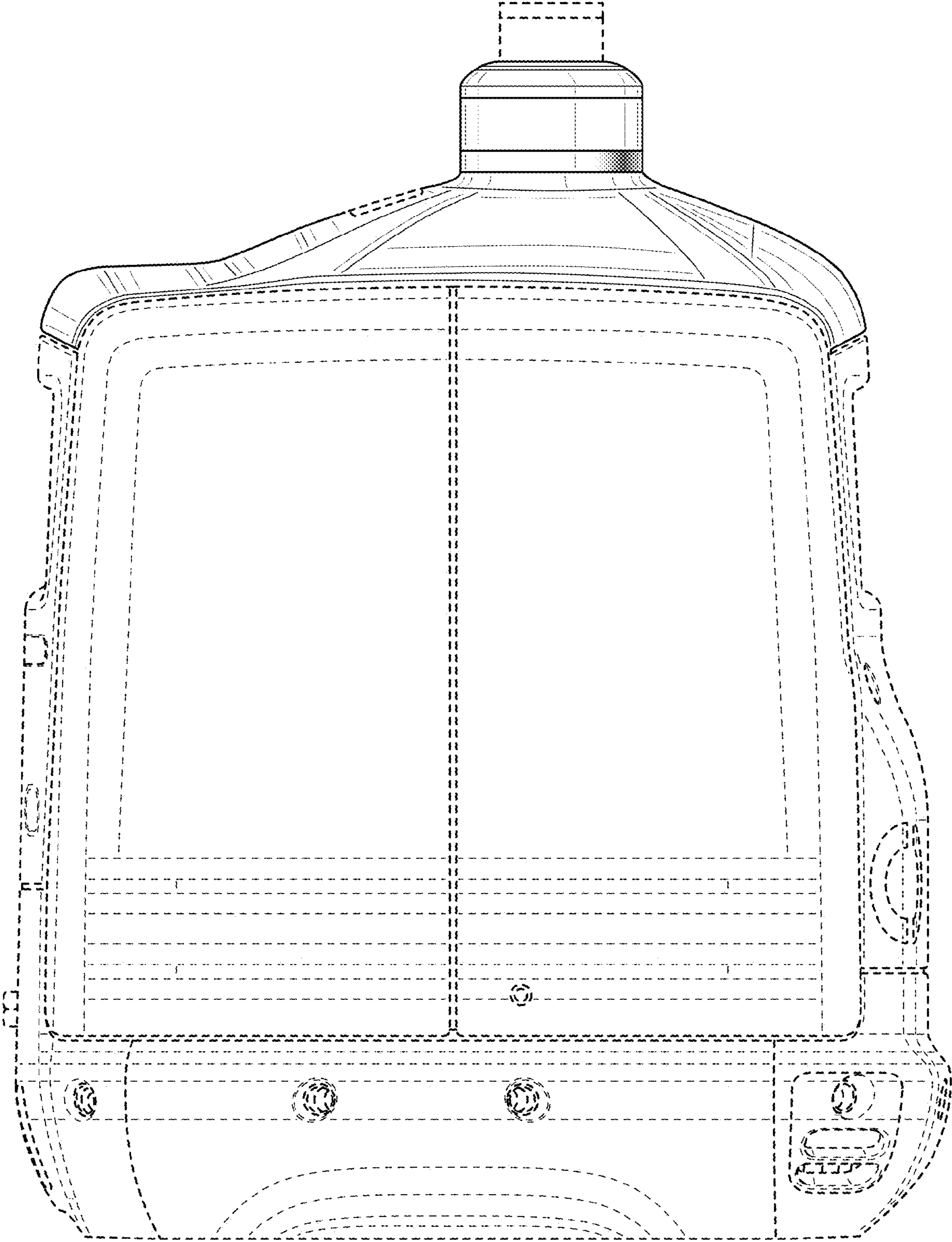

FIG. 4

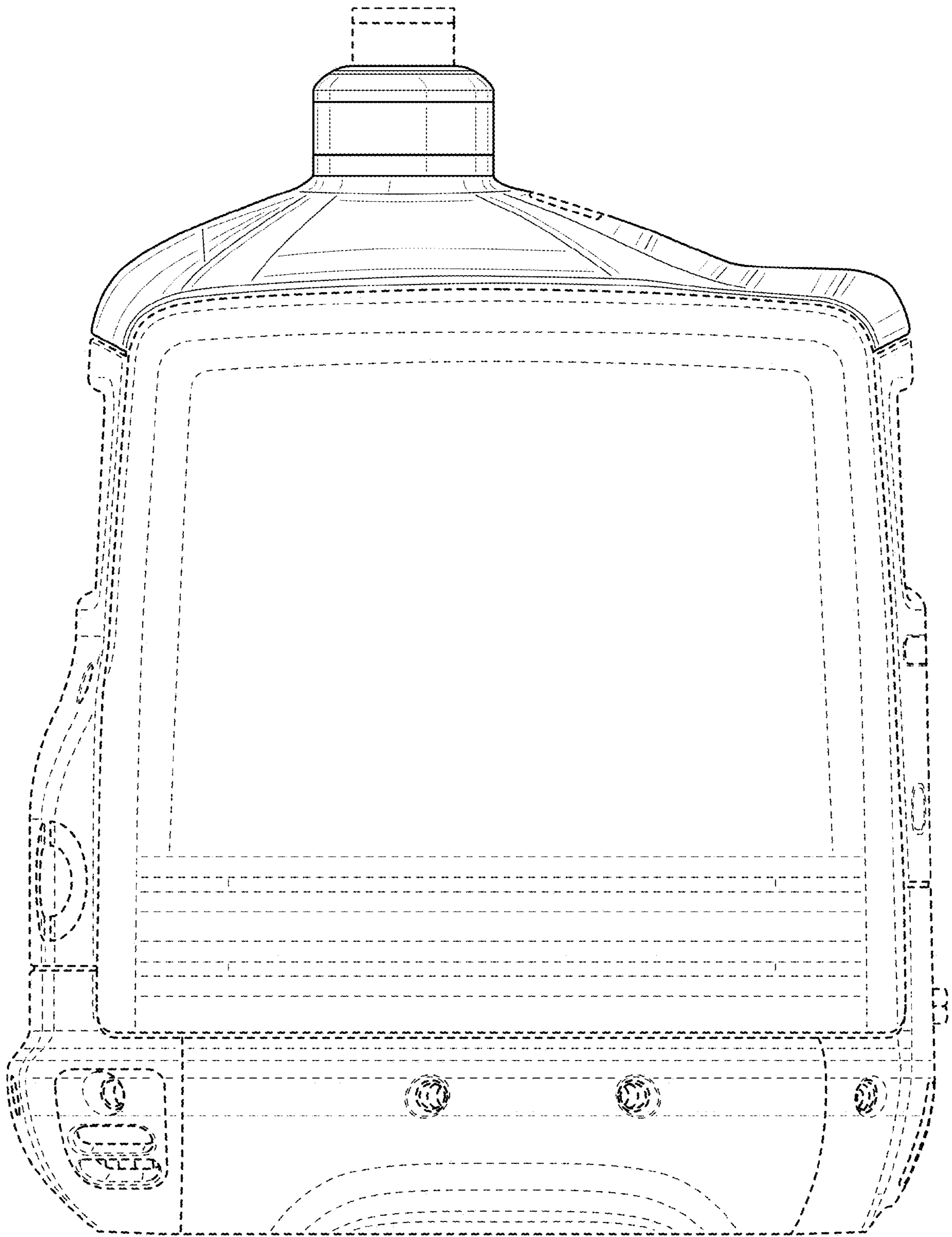

FIG. 5

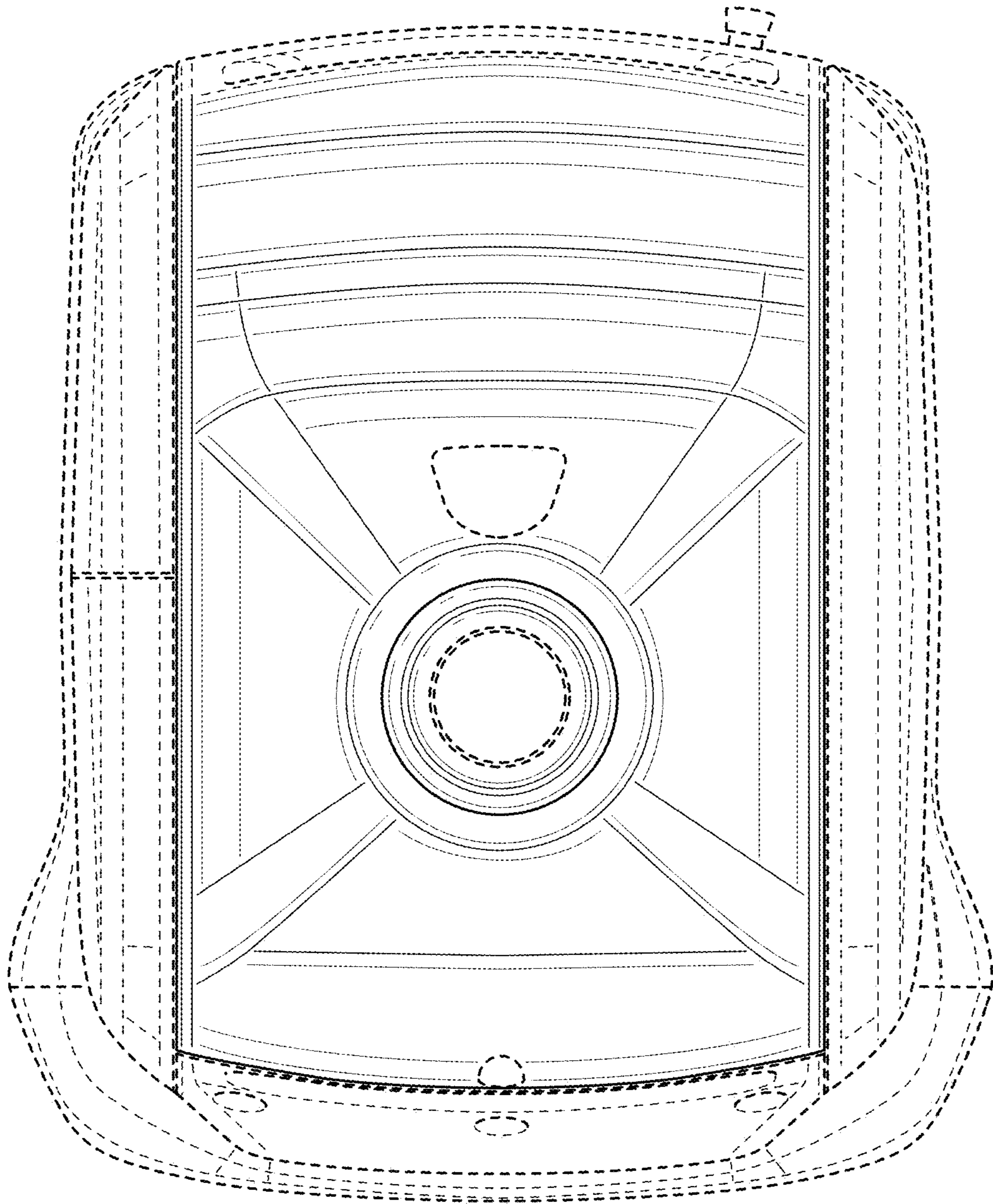

FIG. 6

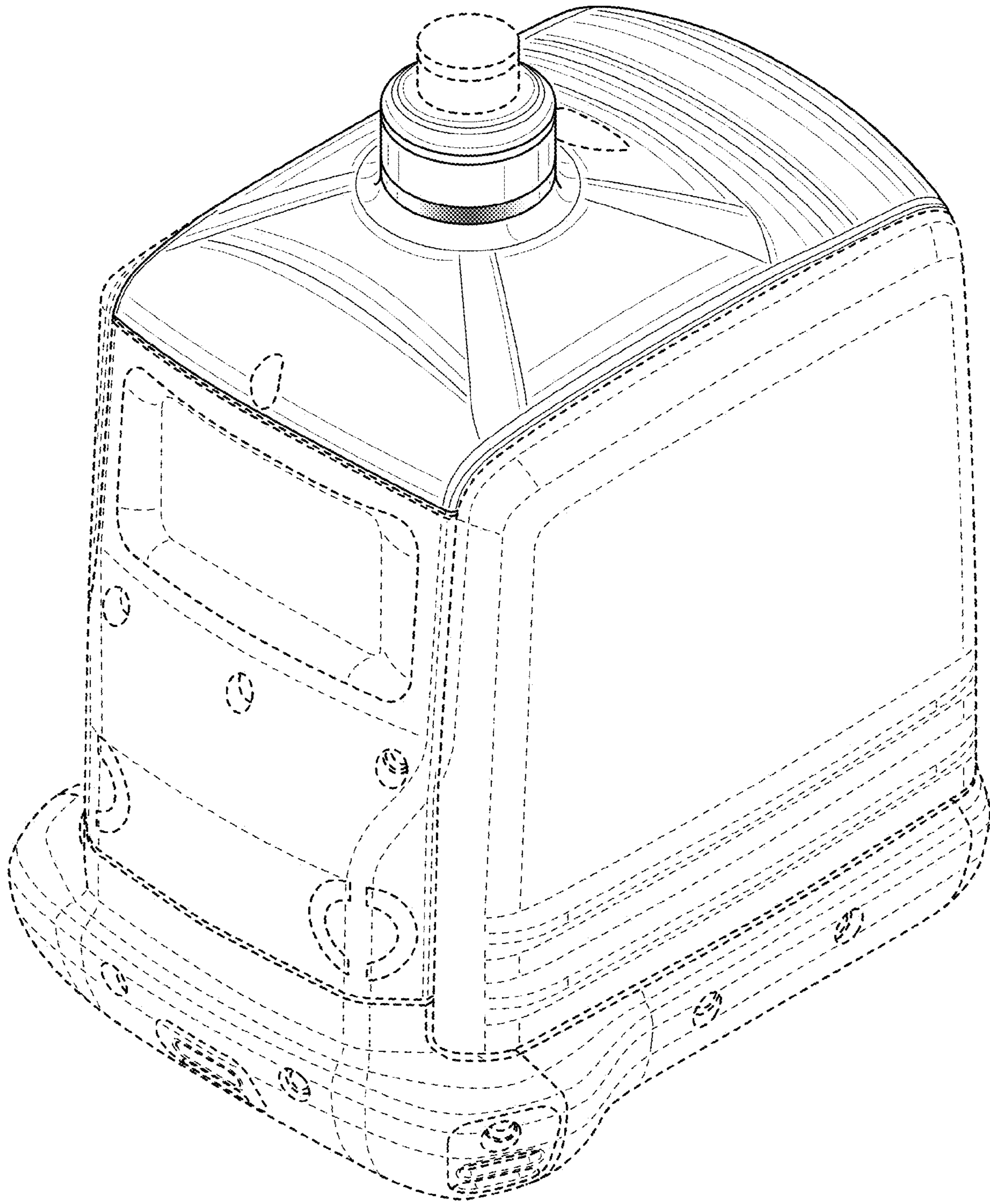

FIG. 7

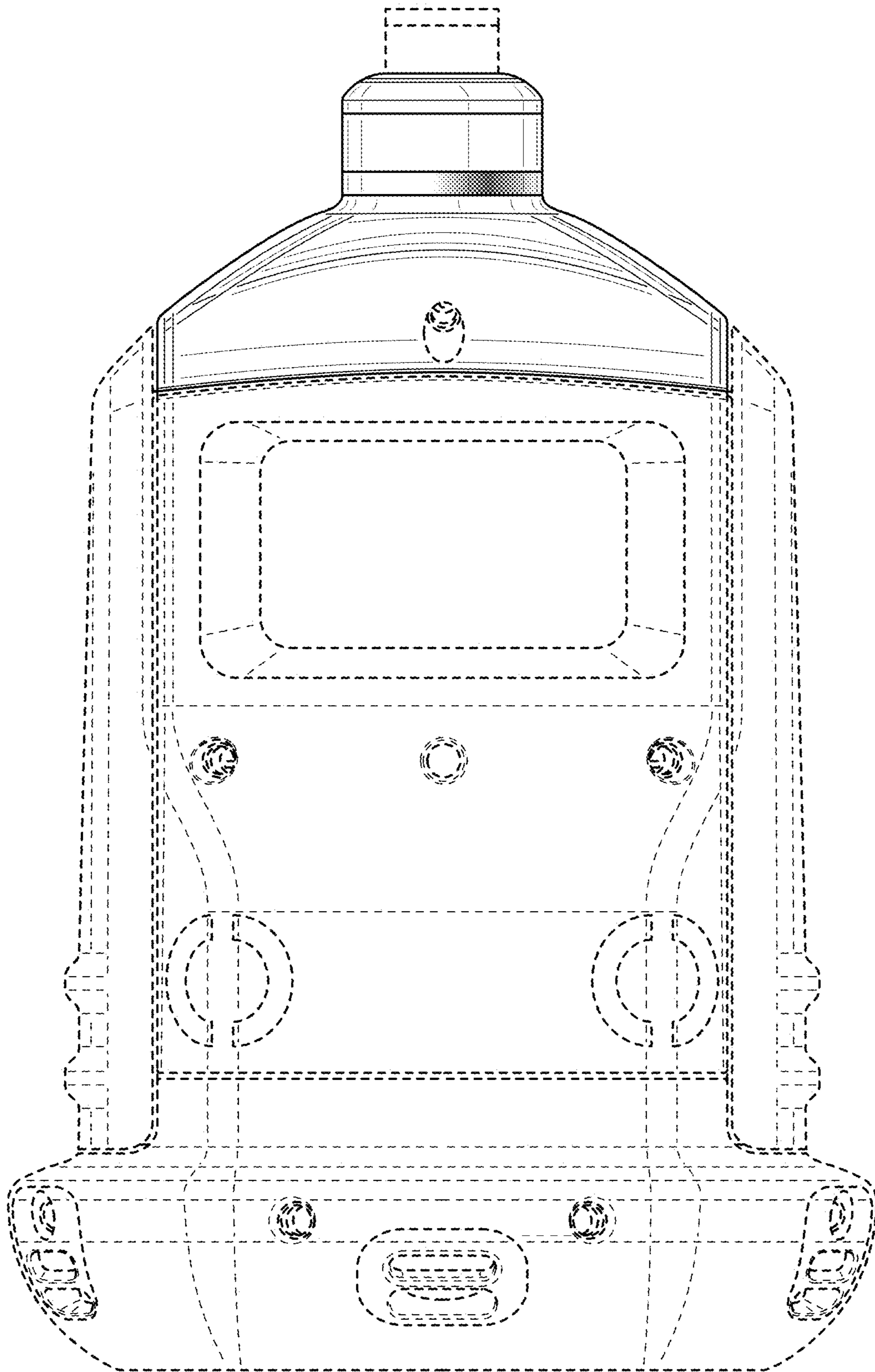

FIG. 8

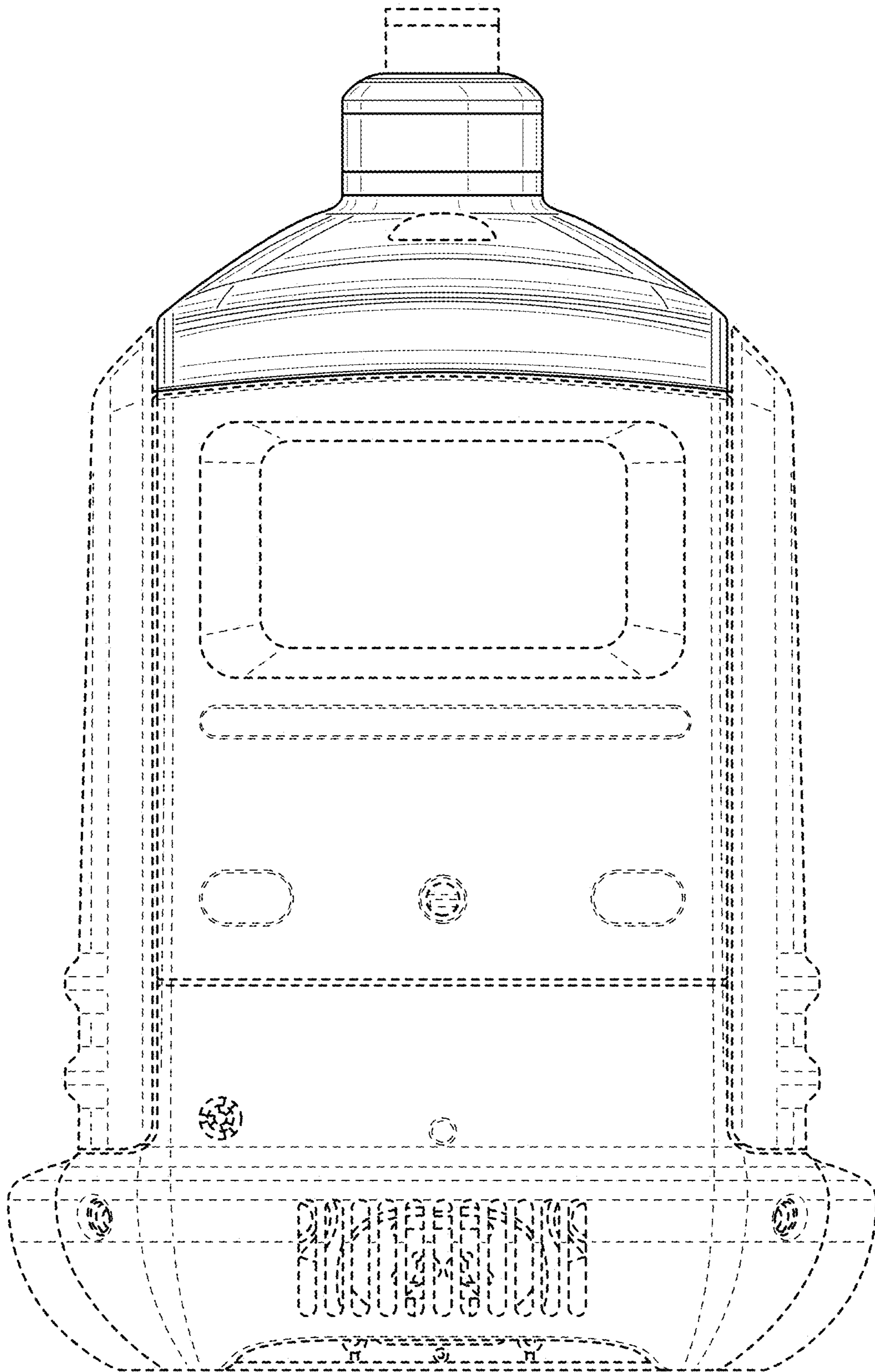

FIG. 9

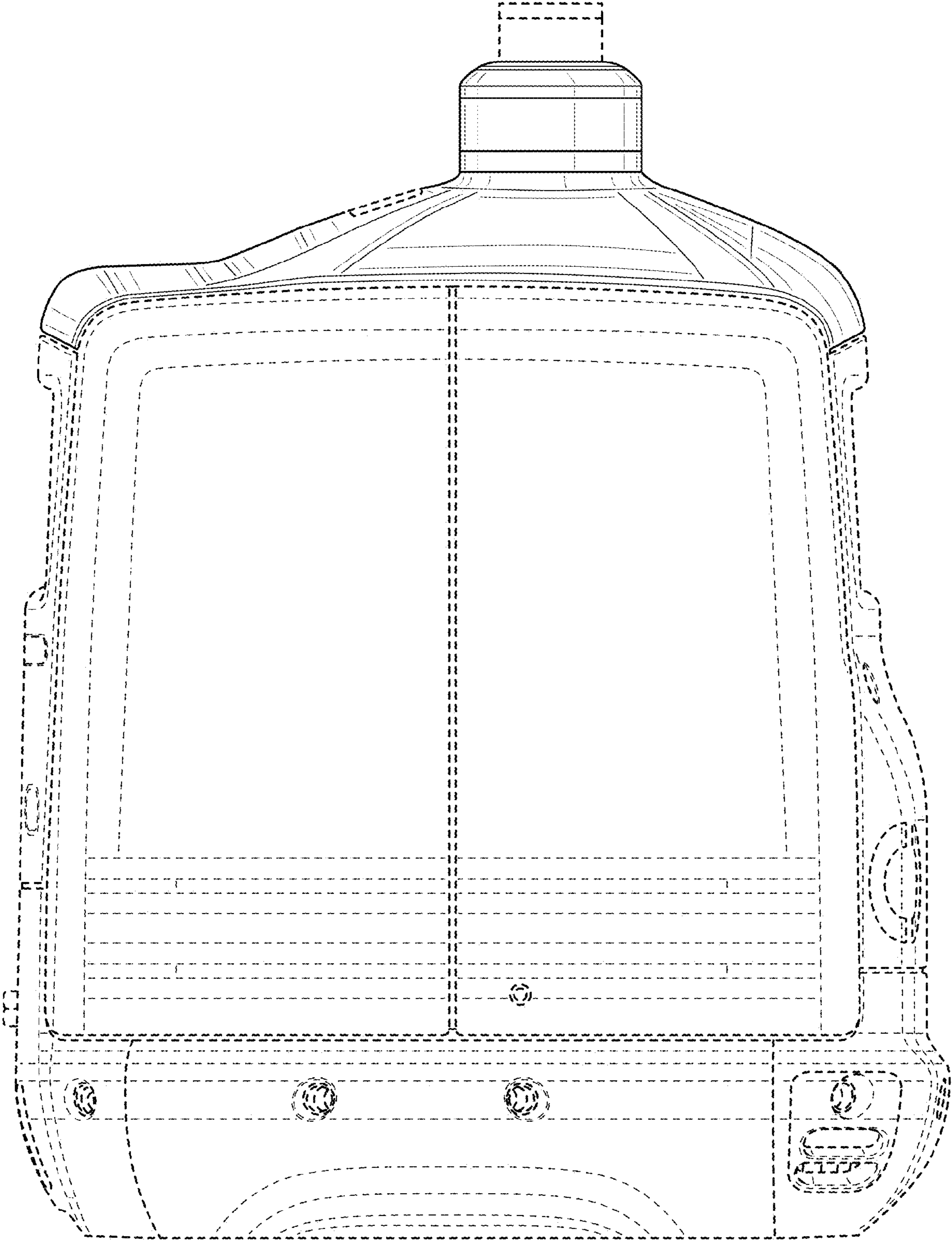

FIG. 10

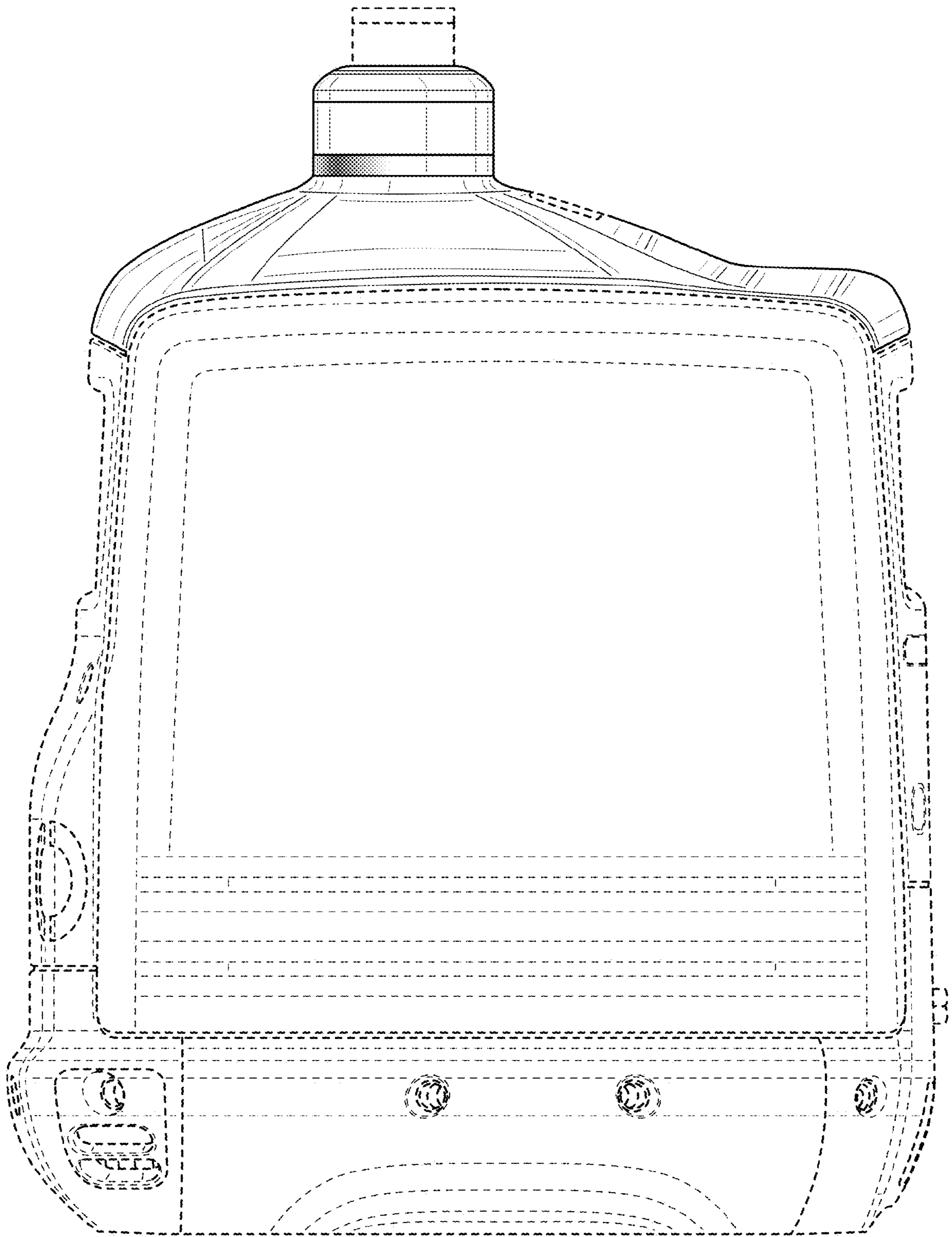

FIG. 11

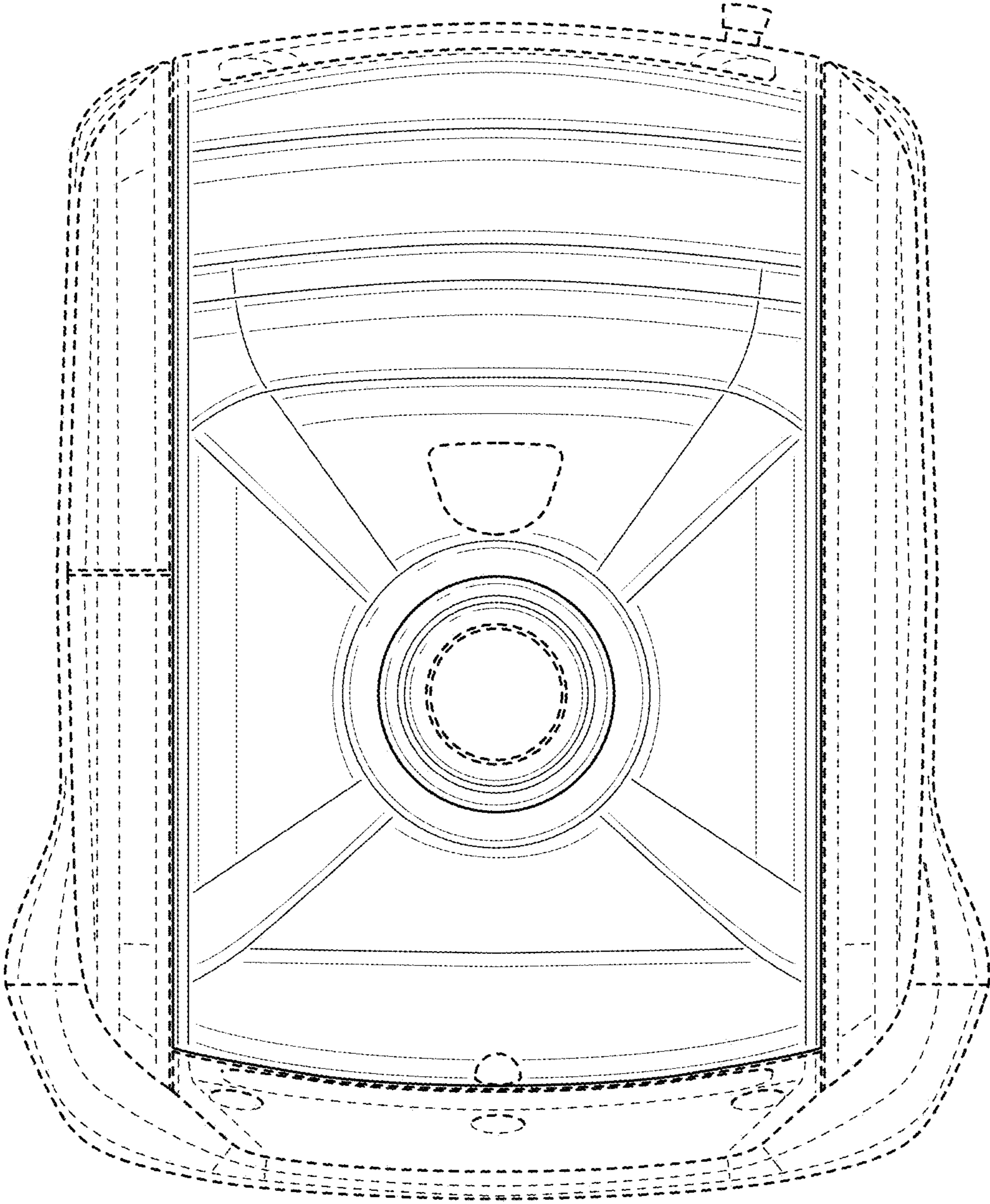

FIG. 12

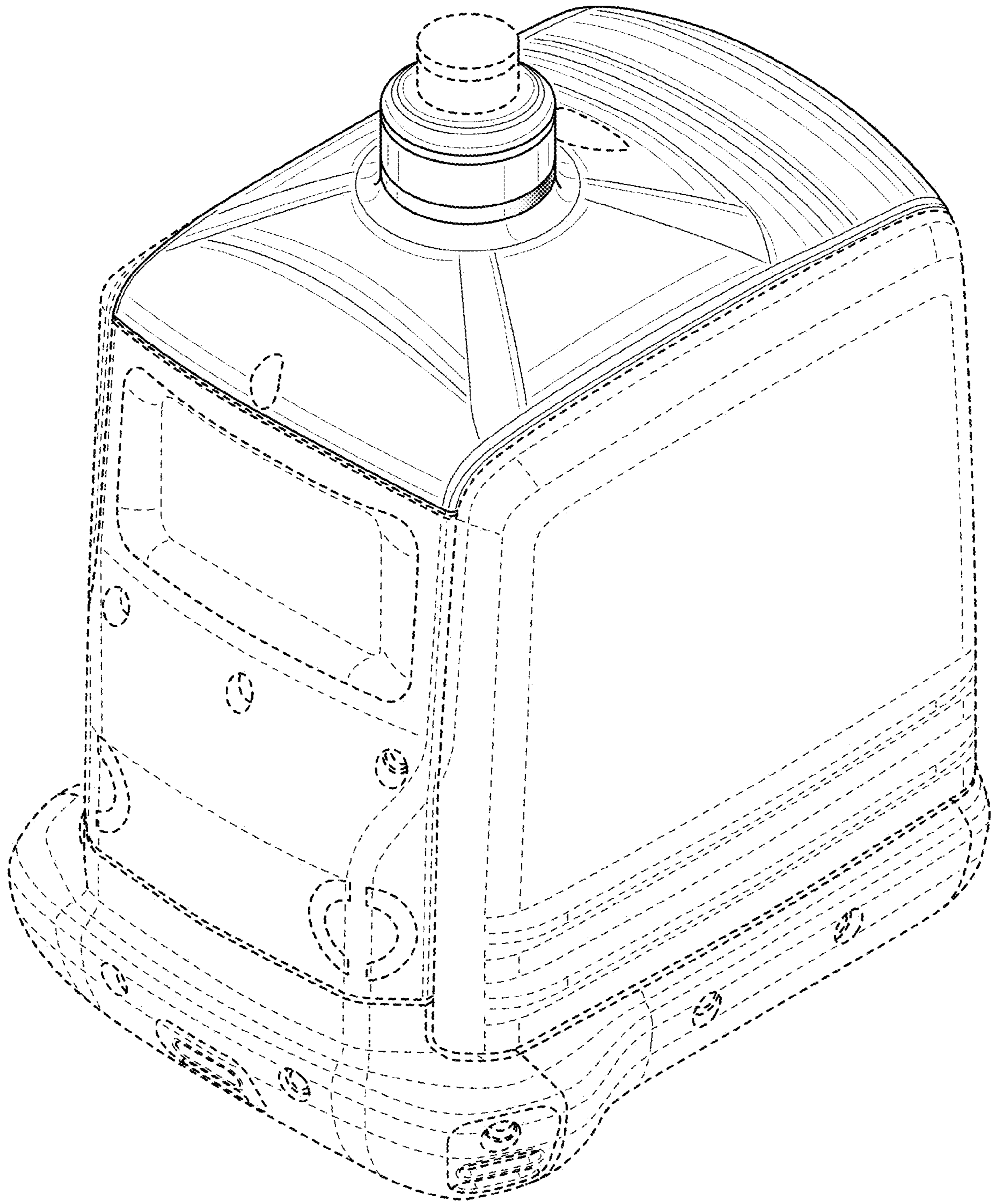

FIG. 13

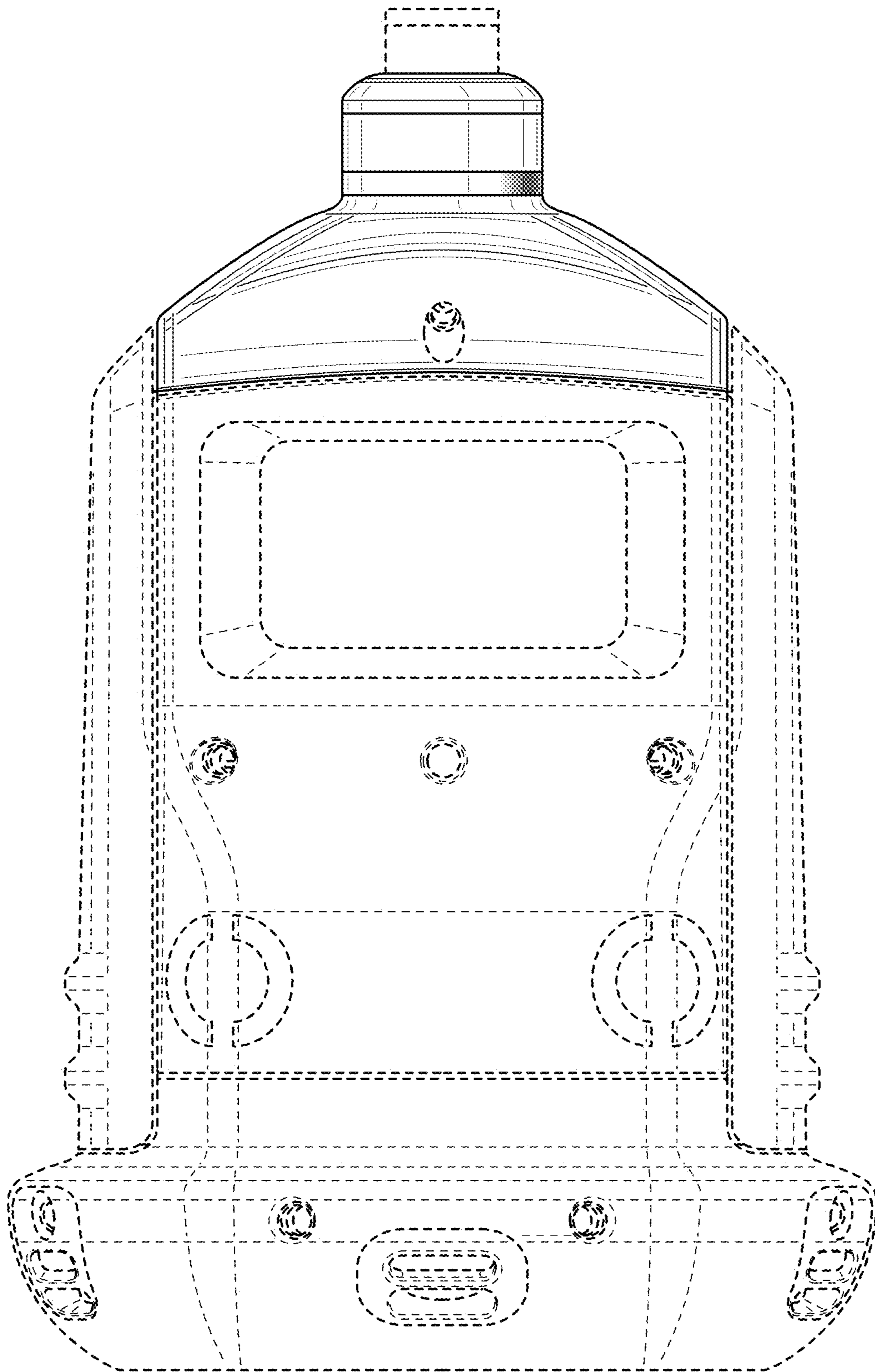

FIG. 14

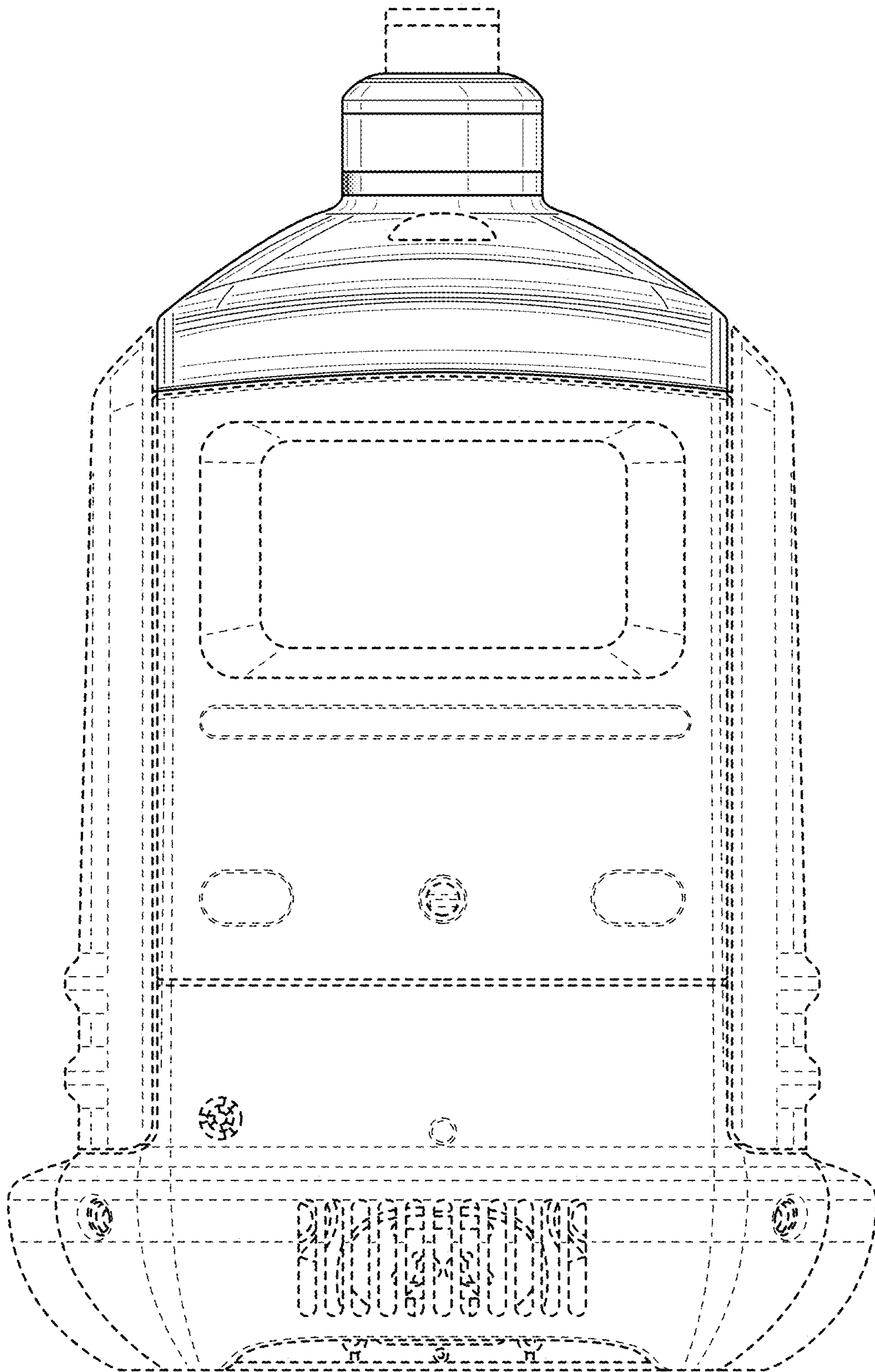

FIG. 15

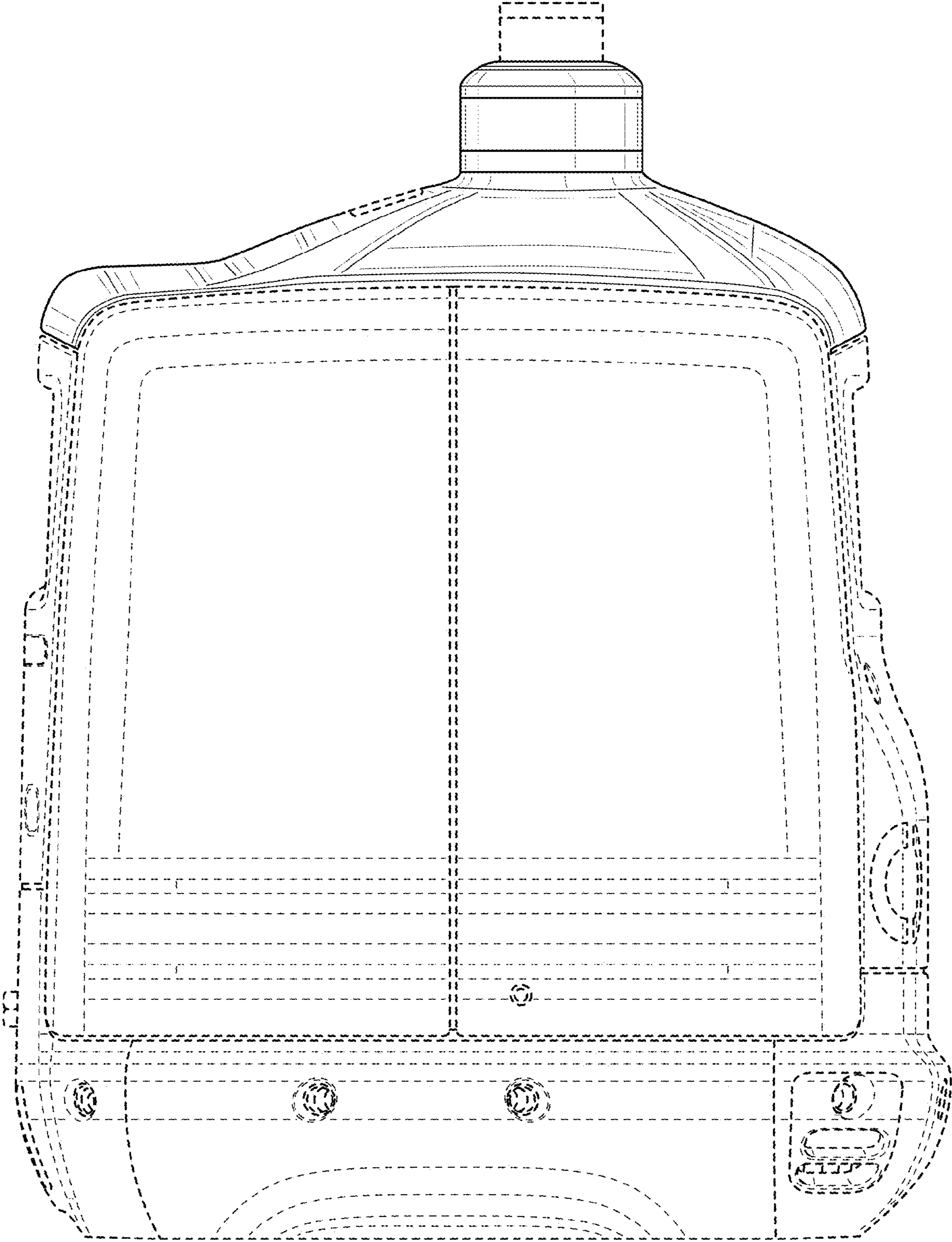

FIG. 16

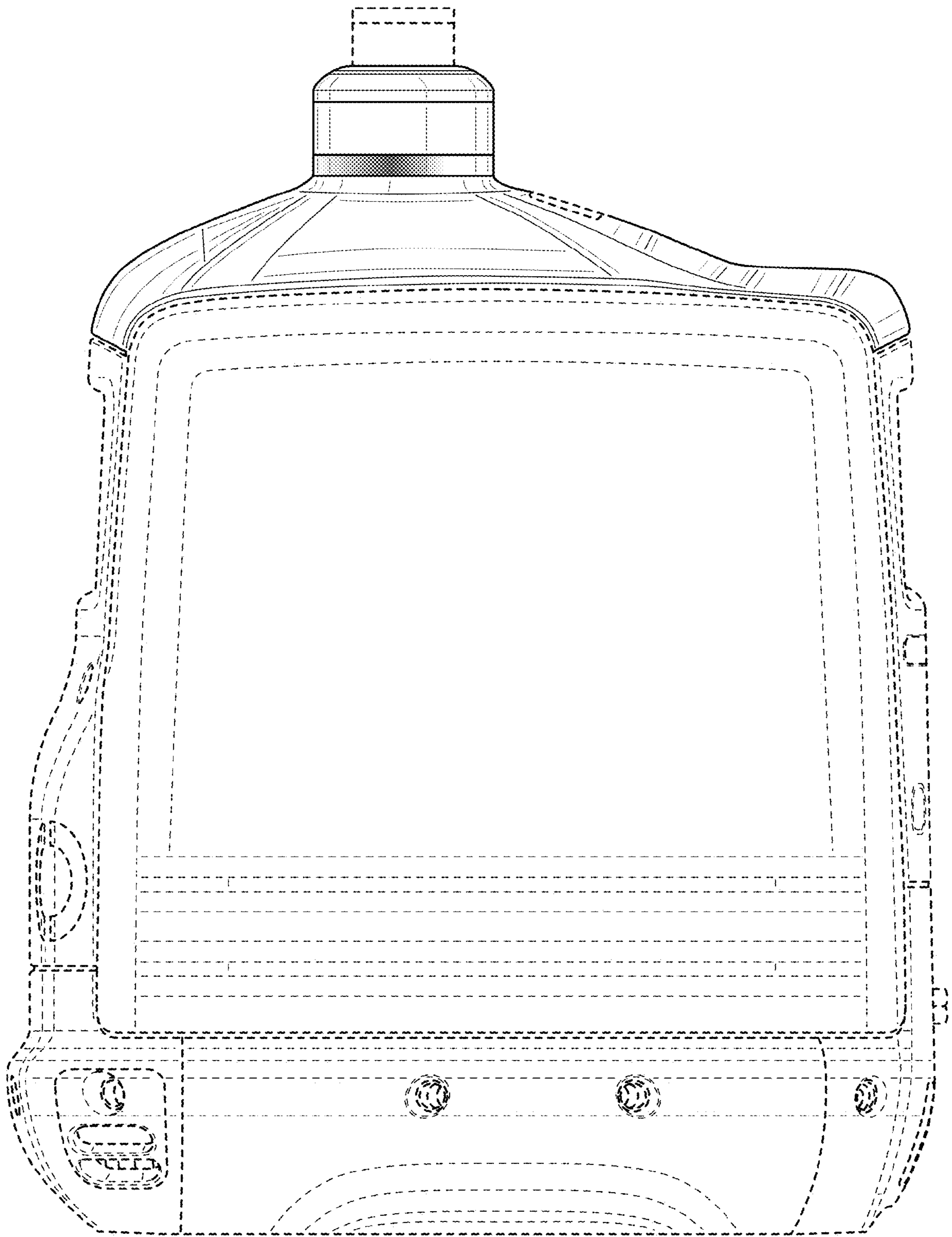

FIG. 17

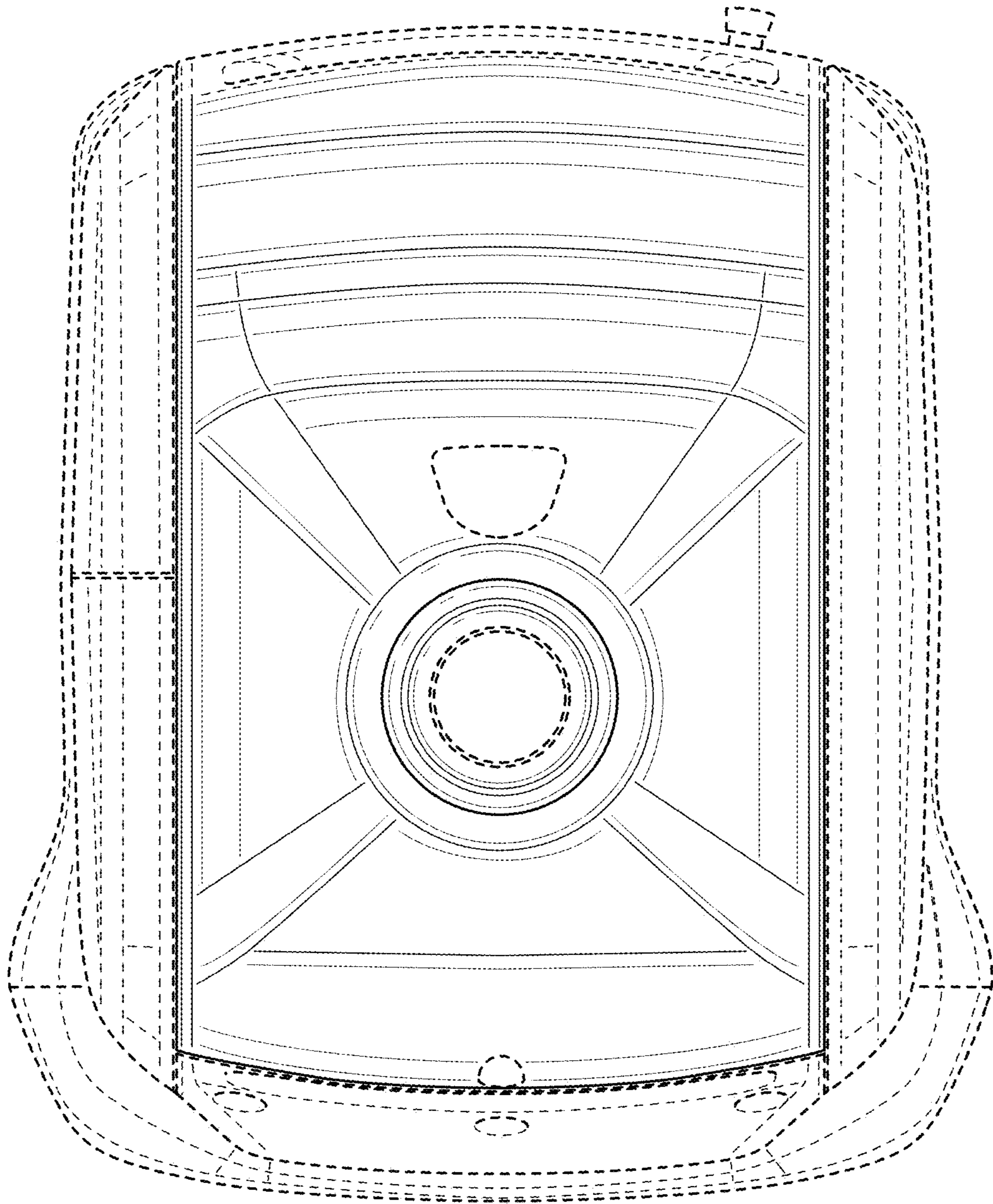

FIG. 18