



US00D984221S

(12) **United States Design Patent**  
**Omdahl, II et al.**

(10) **Patent No.:** **US D984,221 S**  
(45) **Date of Patent:** **\*\* Apr. 25, 2023**

- (54) **BAG**
- (71) Applicant: **Runway Blue, LLC**, Alpine, UT (US)
- (72) Inventors: **John R. Omdahl, II**, Lindon, UT (US);  
**Paul Fair**, Denver, CO (US)
- (73) Assignee: **Runway Blue, LLC**, Alpine, UT (US)
- (\*\*) Term: **15 Years**
- (21) Appl. No.: **29/773,767**
- (22) Filed: **Mar. 11, 2021**
- (51) **LOC (14) Cl.** ..... **07-99**
- (52) **U.S. Cl.**  
USPC ..... **D7/607; D3/283; D3/289**
- (58) **Field of Classification Search**  
USPC ..... D3/232, 234, 244, 245, 246, 318, 321,  
D3/226, 317, 285, 289, 283; D7/625,  
D7/703, 607  
CPC ..... A45C 11/00  
See application file for complete search history.

8,844,756 B2 \* 9/2014 Beyburg ..... A45F 3/46  
220/592.2  
D883,753 S \* 5/2020 Zheng ..... D7/607  
D944,516 S \* 3/2022 Lin ..... D3/285

**OTHER PUBLICATIONS**

Sixpackbags, "Innovator 300 Meal Prep Management Tote", First reviewed Aug. 23, 2011. (<https://www.sixpackbags.com/products/innovator-300-meal-prep-management-tote-pink-black>) (Year: 2011).\*  
BlenderBottle, "Meal Prep Bags", First reviewed May 18, 2022. (<https://www.blenderbottle.com/products/meal-bags?variant=41850603241670>) (Year: 2022).\*

\* cited by examiner

*Primary Examiner* — April Rivas

(74) *Attorney, Agent, or Firm* — Sterne, Kessler, Goldstein & Fox P.L.L.C.

(57) **CLAIM**

The ornamental design for a bag, as shown and described.

**DESCRIPTION**

FIG. 1 is a top front perspective view of a bag showing the claimed design;  
FIG. 2 is a rear perspective view thereof;  
FIG. 3 is a front view thereof;  
FIG. 4 is a rear view thereof;  
FIG. 5 is a left side view thereof;  
FIG. 6 is a right side view thereof;  
FIG. 7 is a top view thereof; and,  
FIG. 8 is a bottom view thereof.

**1 Claim, 8 Drawing Sheets**

(56) **References Cited**

**U.S. PATENT DOCUMENTS**

- D360,526 S \* 7/1995 Roncato ..... D3/276
- D447,667 S \* 9/2001 Schneider ..... D3/289
- D500,594 S \* 1/2005 Zapata ..... D3/268
- D542,031 S \* 5/2007 Zapata ..... D3/268
- 7,313,927 B2 \* 1/2008 Barker ..... F25D 3/08  
62/457.2
- D616,612 S \* 5/2010 Lu ..... D30/109
- D685,181 S \* 7/2013 Burns ..... D3/232

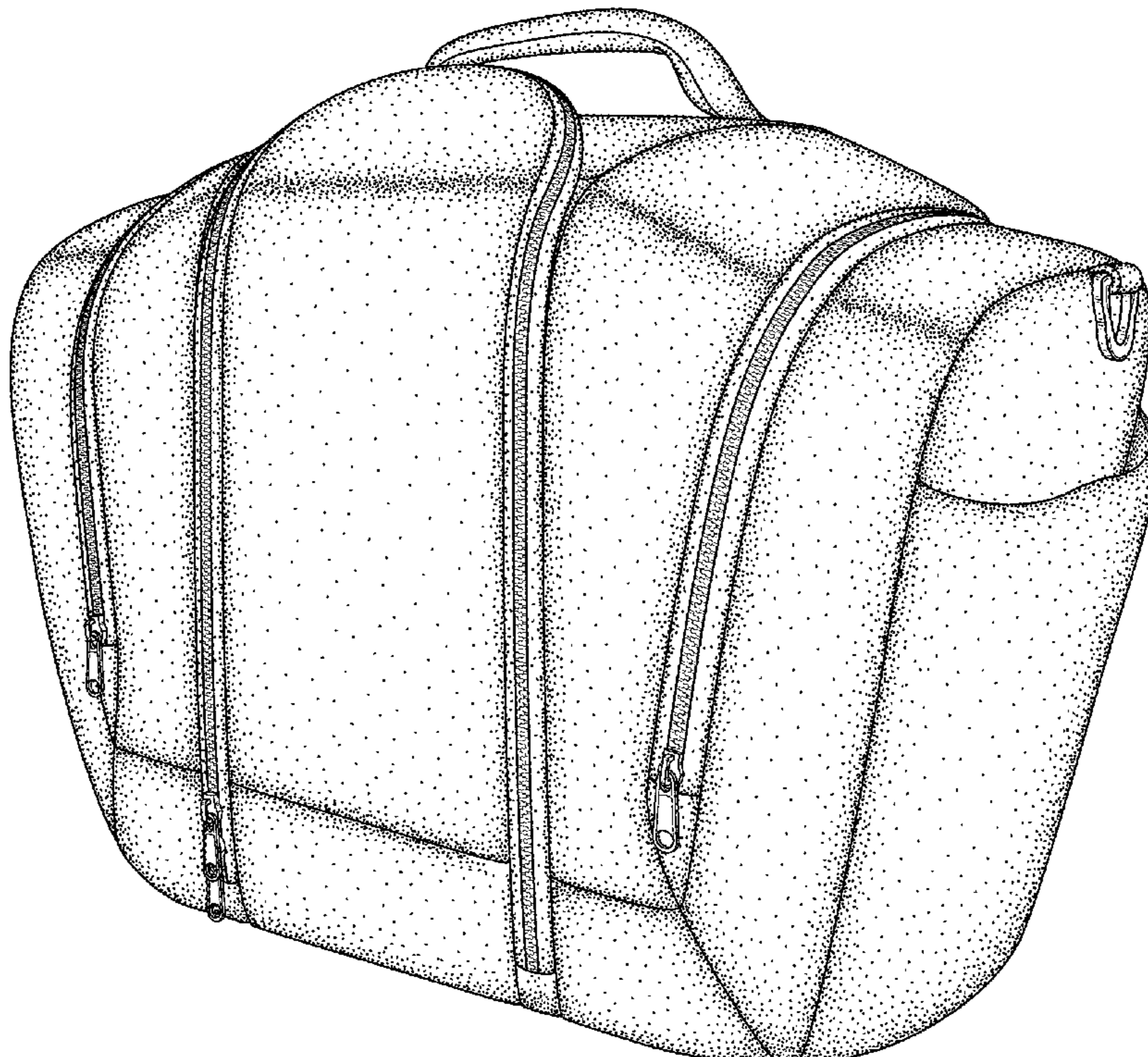

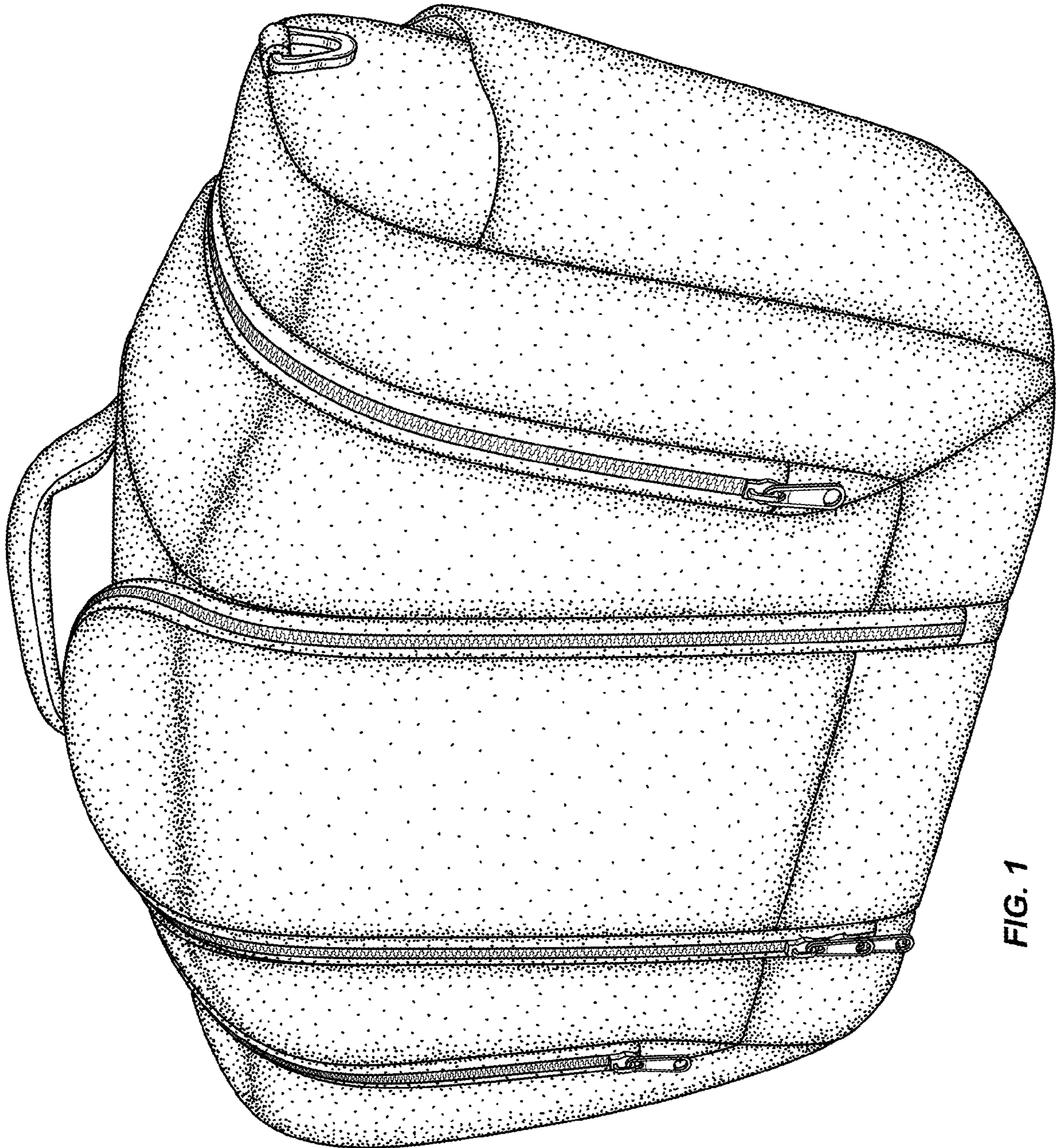

FIG. 1

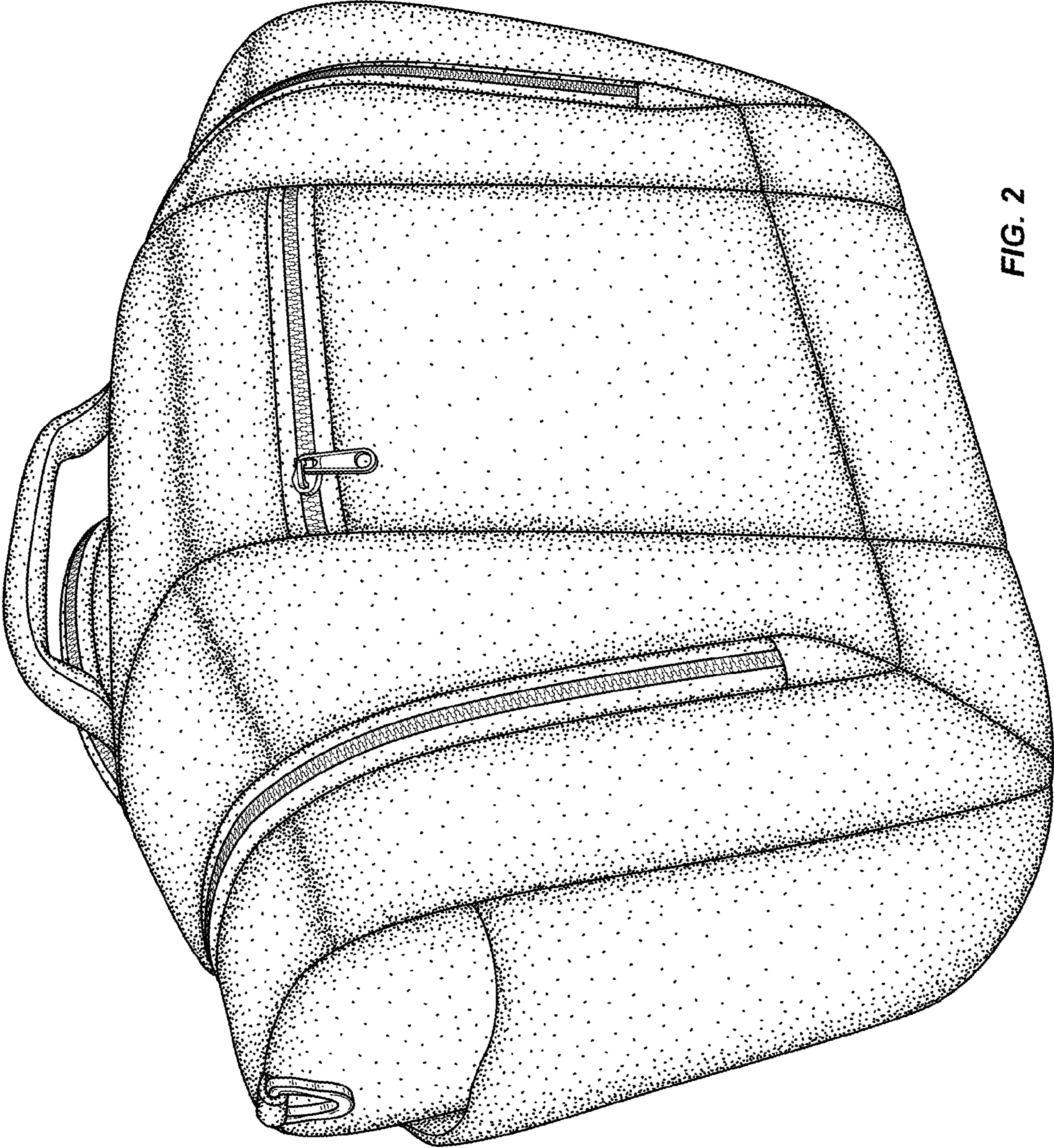

FIG. 2

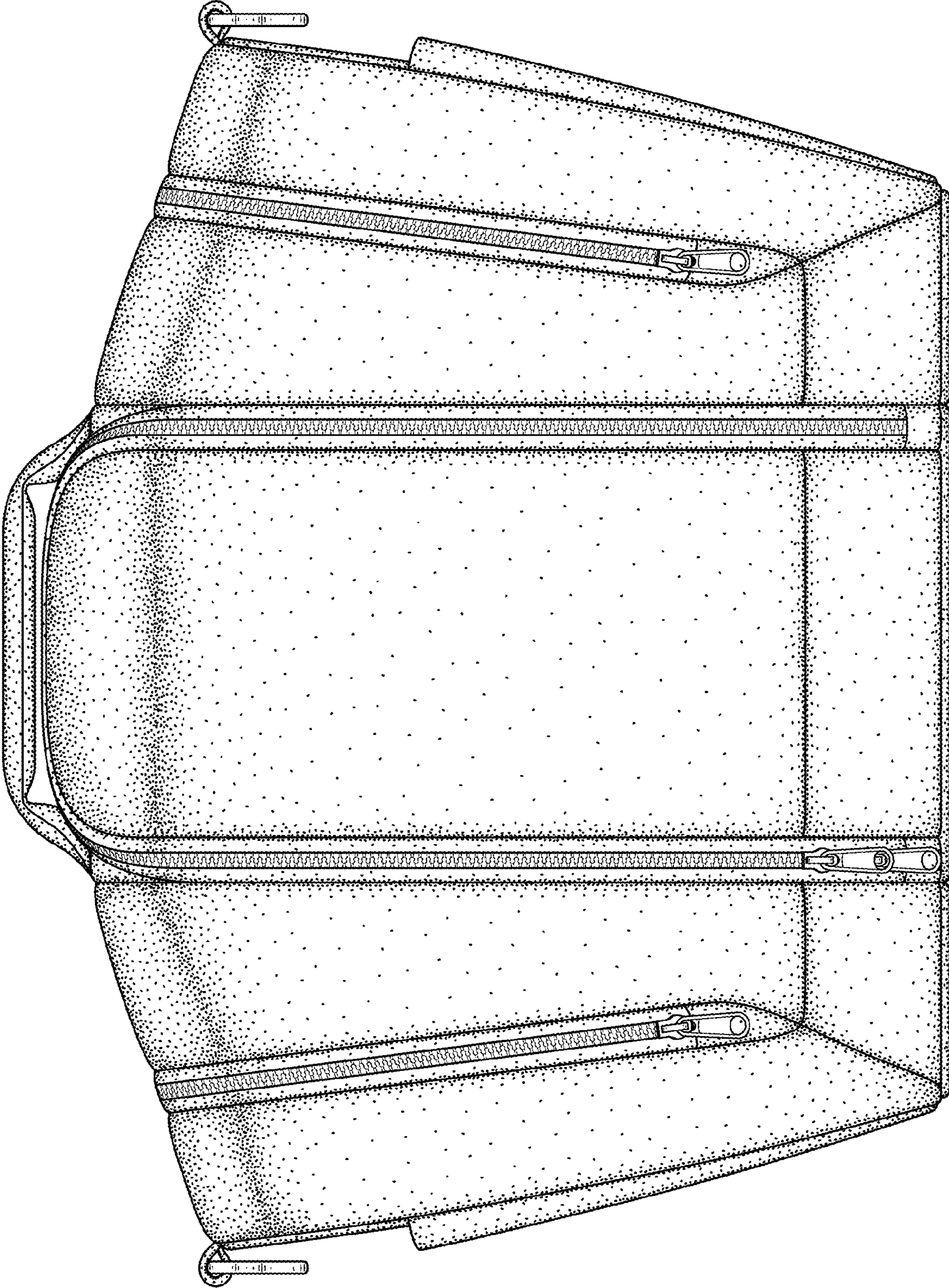

FIG. 3

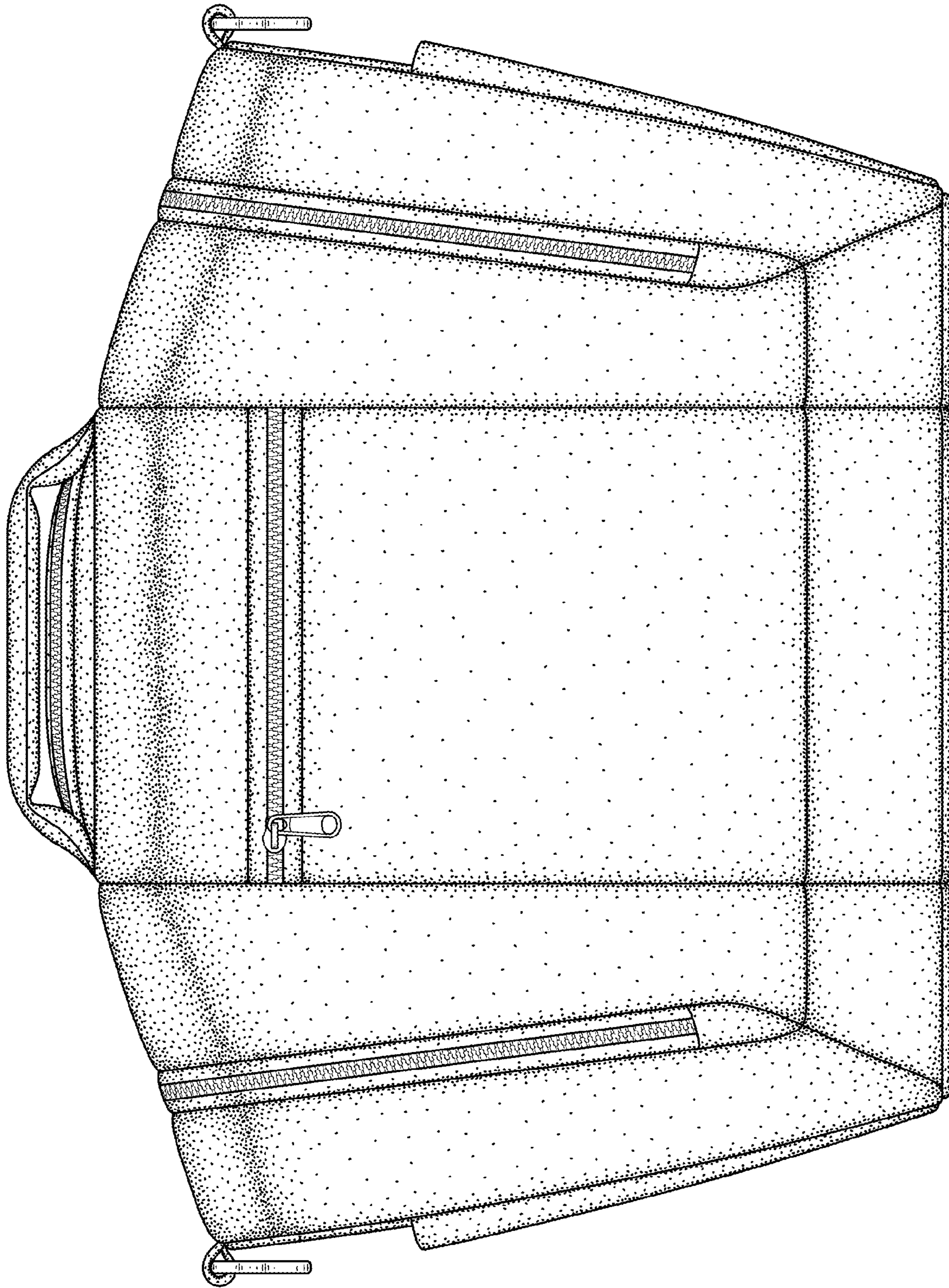

FIG. 4

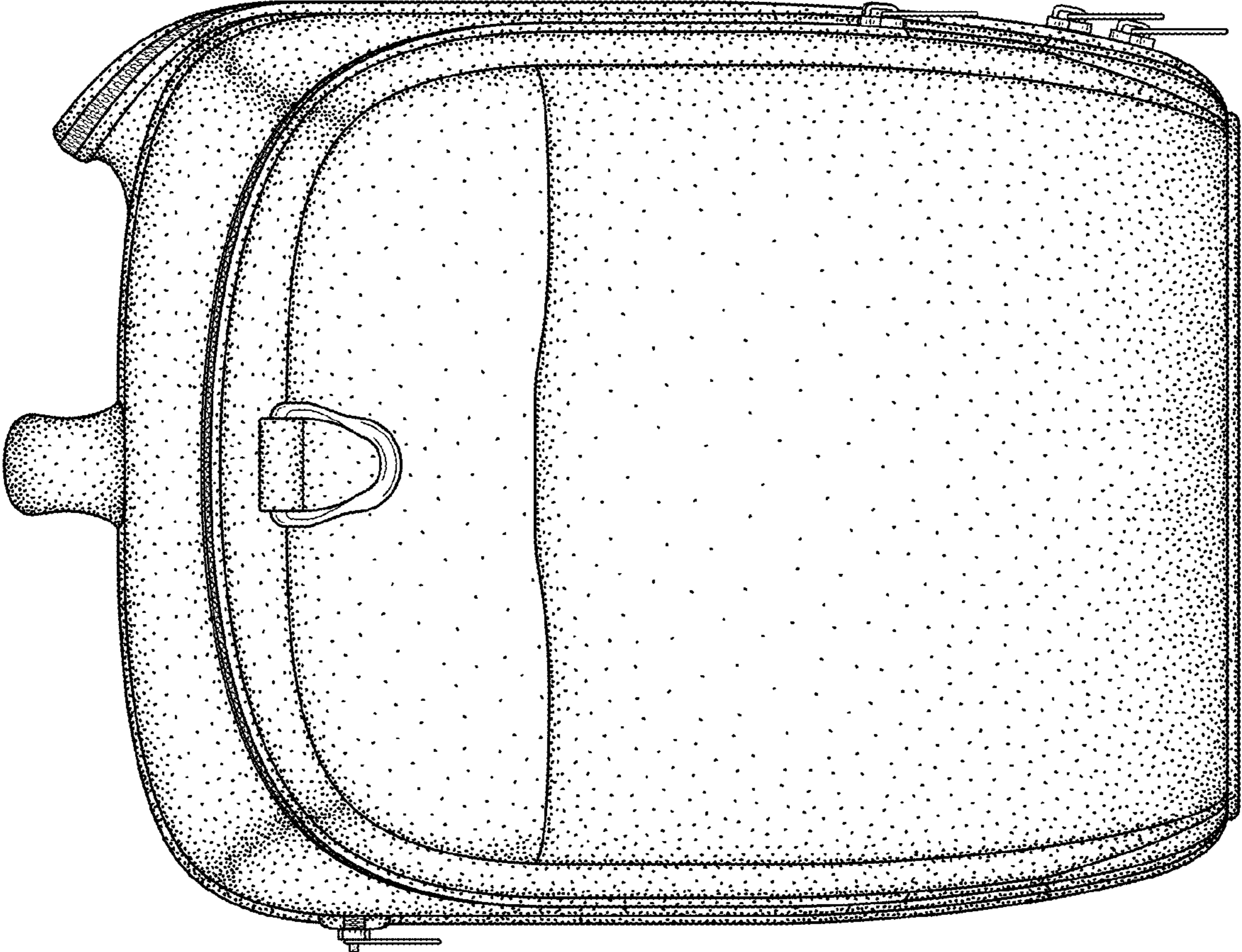

FIG. 5

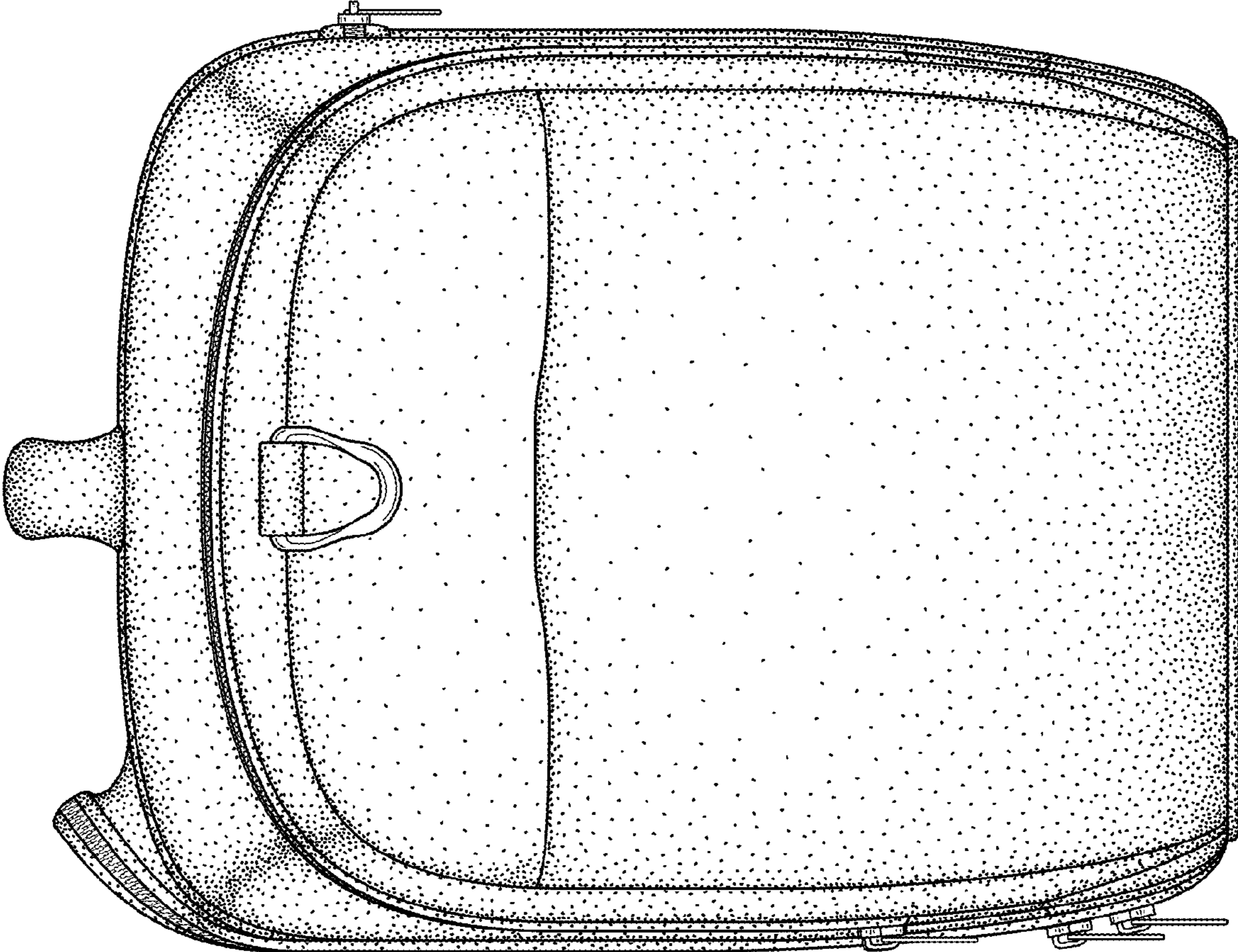

FIG. 6

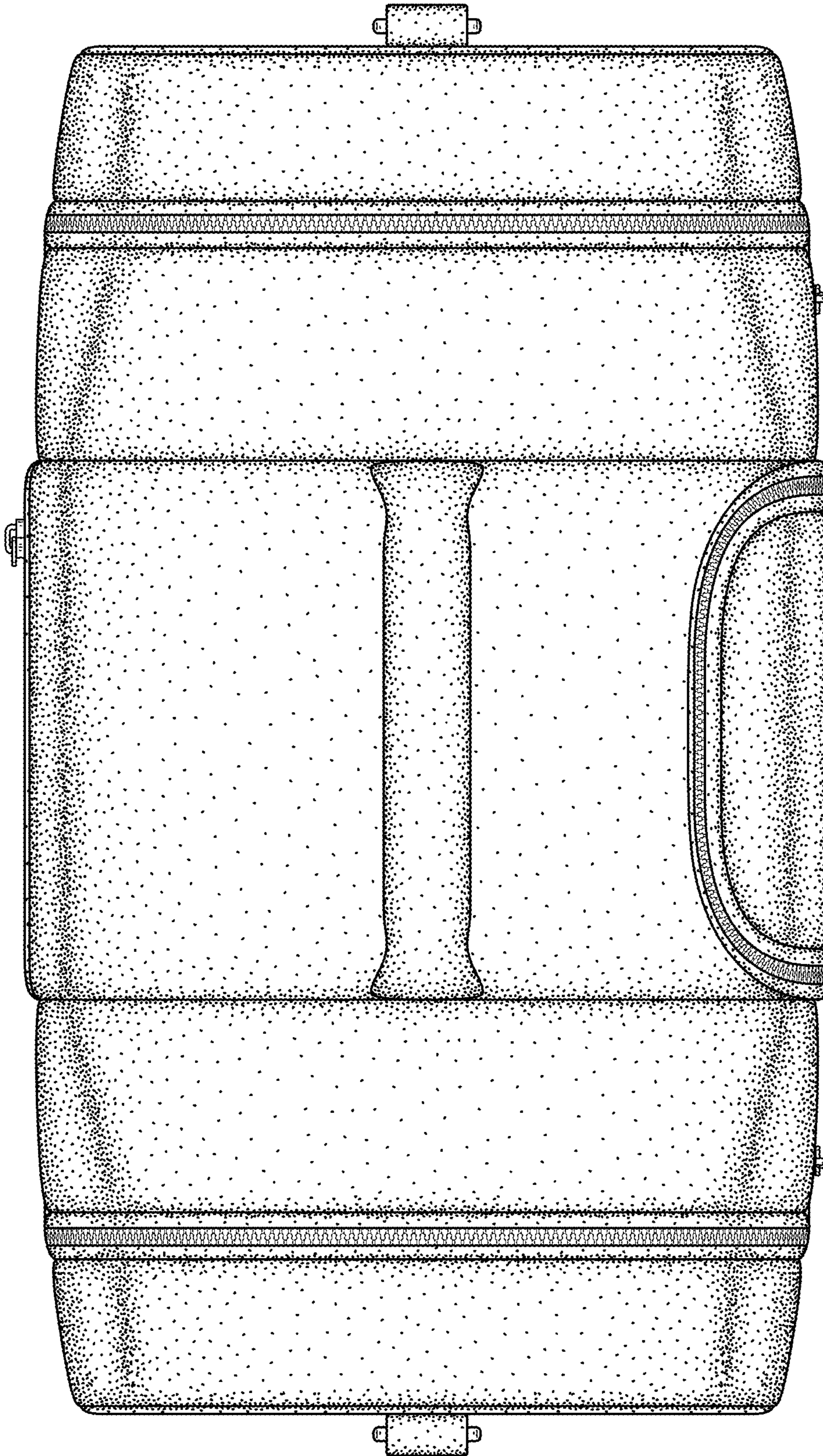

FIG. 7



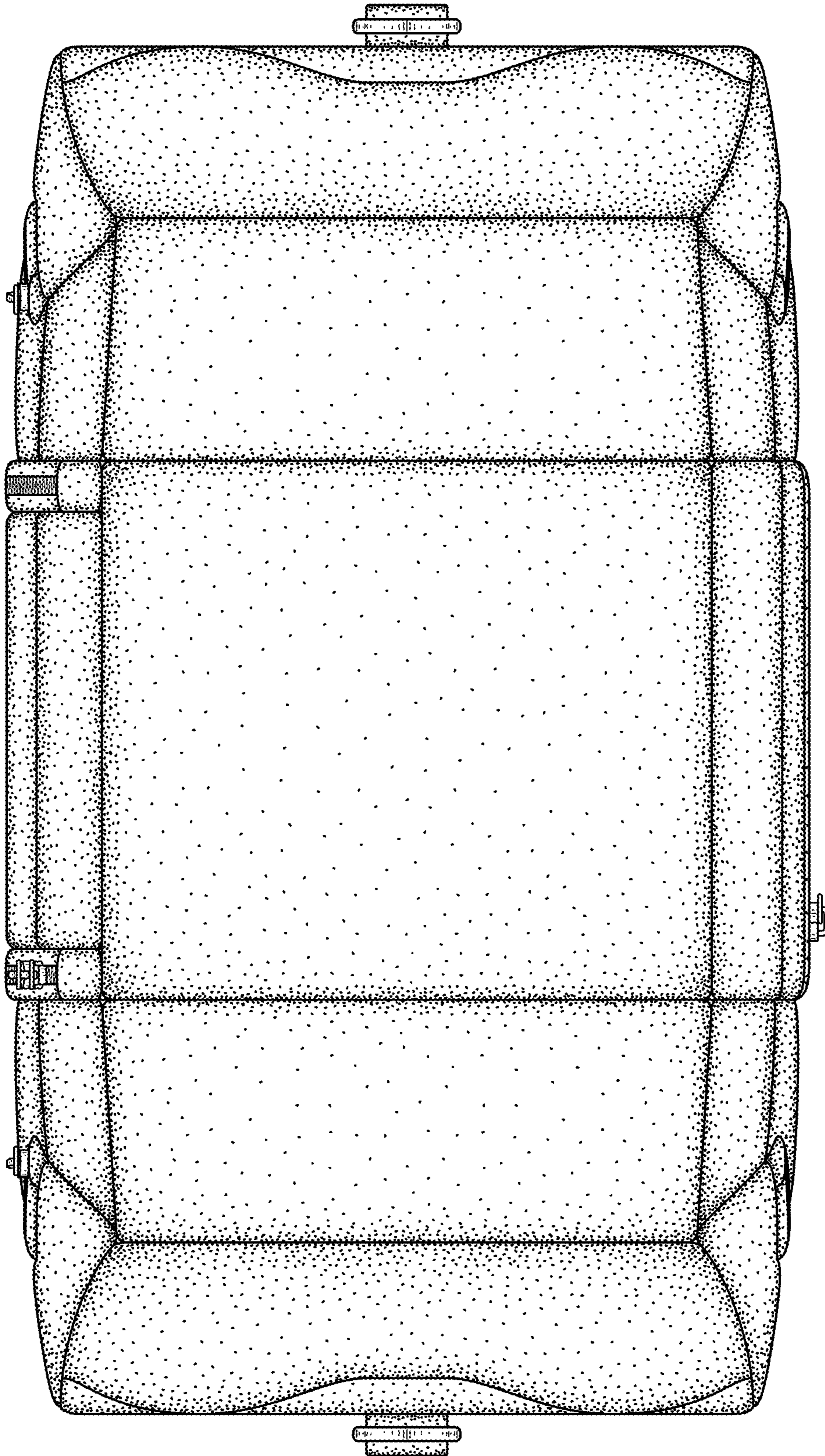

FIG. 8