



US00D983986S

(12) **United States Design Patent**  
**Cheng**

(10) **Patent No.:** **US D983,986 S**

(45) **Date of Patent:** **\*\* Apr. 18, 2023**

(54) **MESSAGE GUN**

(71) Applicant: **Guomei Cheng**, Jiangsu (CN)

(72) Inventor: **Guomei Cheng**, Jiangsu (CN)

(73) Assignee: **NANJING YUNKAI MACHINERY CO., LTD**, Nanjing (CN)

(\*\*) Term: **15 Years**

(21) Appl. No.: **29/752,472**

(22) Filed: **Sep. 28, 2020**

(51) **LOC (14) Cl.** ..... **28-03**

(52) **U.S. Cl.**  
USPC ..... **D24/215**

(58) **Field of Classification Search**  
USPC ..... D24/215, 200, 211, 212, 213, 214, 133,  
D24/107, 231, 184; D8/14.1, 61;  
D28/12, 13  
CPC ..... A61H 15/00; A61H 2015/0007; A61H  
2015/0042; A61H 15/0092; A61H  
15/0078; A61H 15/0085; A61H 23/00;  
A61H 23/006; A61H 2023/002; A61H  
23/02; A61H 2201/0153; A61H 7/00;  
A61H 7/003; A61H 7/004; A61H 7/005;  
A61H 9/00; A61H 2205/06

See application file for complete search history.

(56) **References Cited**

**U.S. PATENT DOCUMENTS**

|                 |         |          |       |            |
|-----------------|---------|----------|-------|------------|
| D457,044 S *    | 5/2002  | Cheng    | ..... | D8/29.1    |
| D679,561 S *    | 4/2013  | Price    | ..... | D8/29.1    |
| D742,708 S *    | 11/2015 | Howell   | ..... | D8/29.1    |
| 10,428,850 B2 * | 10/2019 | Wersland | ..... | A61H 1/008 |
| D872,869 S *    | 1/2020  | Lu       | ..... | D24/215    |
| D877,351 S *    | 3/2020  | Wersland | ..... | D24/215    |
| D879,986 S *    | 3/2020  | Wersland | ..... | D24/214    |
| D893,738 S *    | 8/2020  | Zhuang   | ..... | D24/215    |

|                   |         |          |       |              |
|-------------------|---------|----------|-------|--------------|
| D895,133 S *      | 9/2020  | Xu       | ..... | D24/215      |
| D896,396 S *      | 9/2020  | Wersland | ..... | D24/215      |
| D898,209 S *      | 10/2020 | Xu       | ..... | D24/214      |
| D925,755 S *      | 7/2021  | Zheng    | ..... | D24/215      |
| D949,390 S *      | 4/2022  | Wersland | ..... | D24/215      |
| 2017/0304145 A1 * | 10/2017 | Pepe     | ..... | A61H 23/02   |
| 2020/0261306 A1 * | 8/2020  | Pepe     | ..... | A61H 23/006  |
| 2020/0268594 A1 * | 8/2020  | Pepe     | ..... | A61H 15/0085 |
| 2020/0352820 A1 * | 11/2020 | Nazarian | ..... | H02K 11/26   |

**OTHER PUBLICATIONS**

Recoveryvolt—RecoveryPro Massage Gun. Date: Dec. 18, 2019. [online]. [Site visited Apr. 7, 2022]. Available from Internet URL: <https://www.amazon.com/dp/B07RGRLH5L> (Year: 2019).\*  
RxGun—QUIETec Vibration Percussion Massager. Date: Dec. 1, 2018. [online]. [Site visited Apr. 22, 2022]. Available from Internet URL: <https://us.amazon.com/dp/B07MCYXYW8/> (Year: 2018).\*

(Continued)

*Primary Examiner* — Eliza Z Harvey  
*Assistant Examiner* — Landon Thomas Cassell  
(74) *Attorney, Agent, or Firm* — Georgi Korobanov

(57) **CLAIM**

The ornamental design for a massage gun, as shown and described.

**DESCRIPTION**

FIG. 1 is a perspective view of a massage gun showing my new design;  
FIG. 2 is a front elevational view thereof;  
FIG. 3 is a rear elevational view thereof;  
FIG. 4 is a left side elevational view thereof;  
FIG. 5 is a right side elevational view thereof;  
FIG. 6 is a top plan view thereof; and,  
FIG. 7 is a bottom plan view thereof.  
The broken lines in the drawings depict portions of the massage gun and form no part of the claimed design.

**1 Claim, 5 Drawing Sheets**

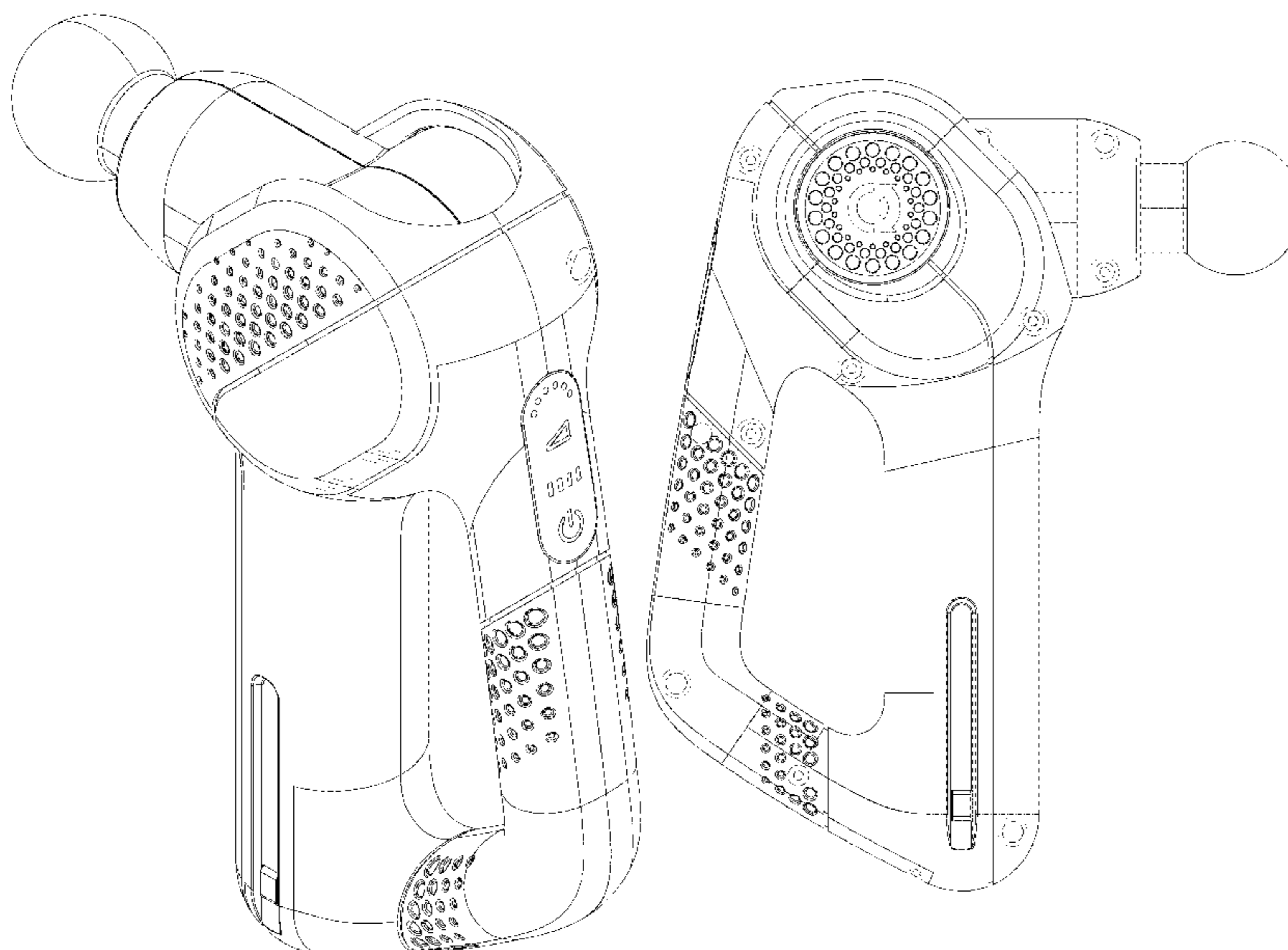

(56)

**References Cited**

OTHER PUBLICATIONS

Massagers. (Design-© Questel) orbit.com. [Online PDF compilation of references] 51 pgs. Print Dates Range Jan. 22, 2019-Oct. 27, 2020 [Retrieved Apr. 21, 2022] <https://www.orbit.com/export/UCZAH96B/pdf4/aa224af4-0953-490a-ae0c-d058744d2dee-201826.pdf> (Year: 2022).\*

\* cited by examiner

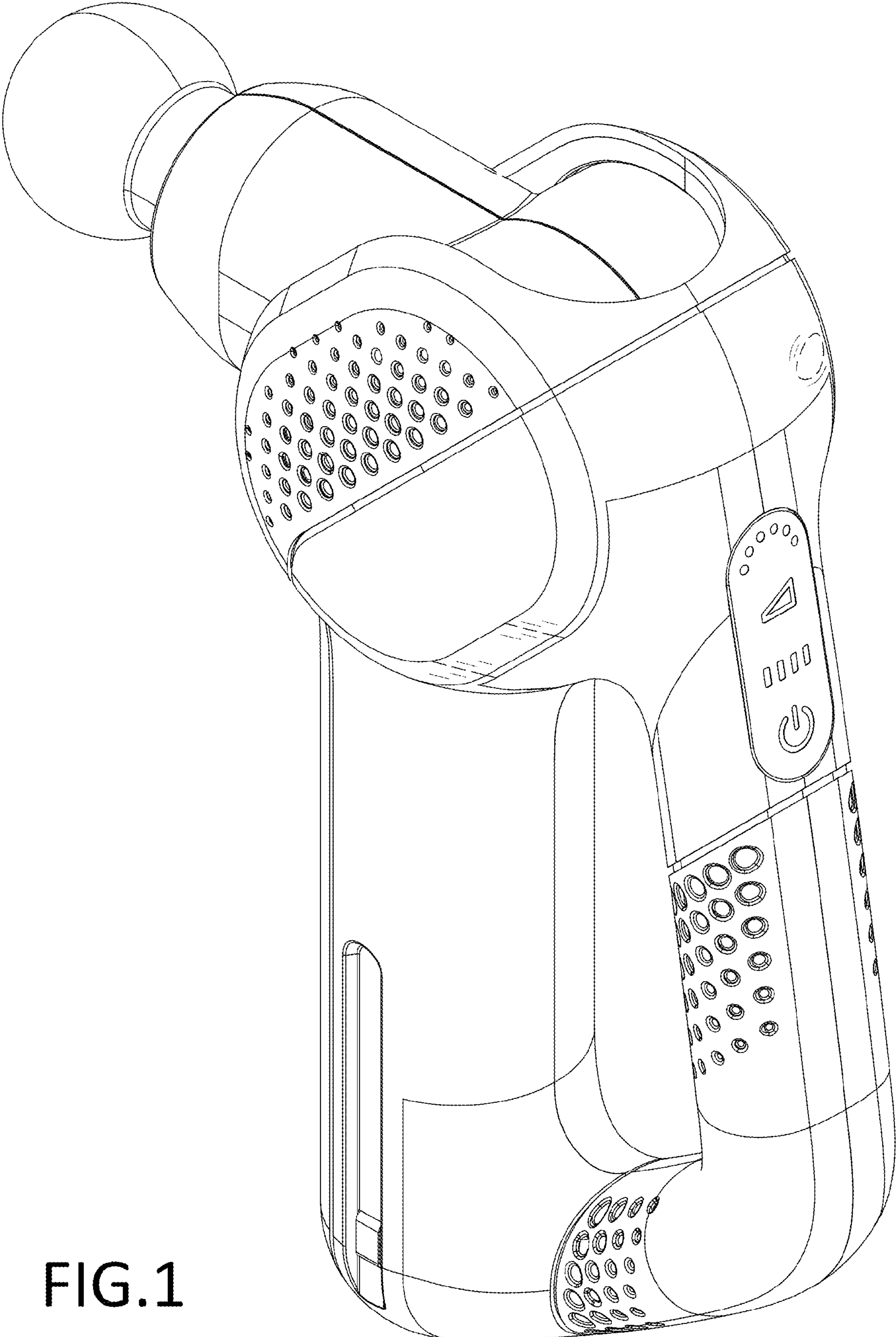

FIG.1

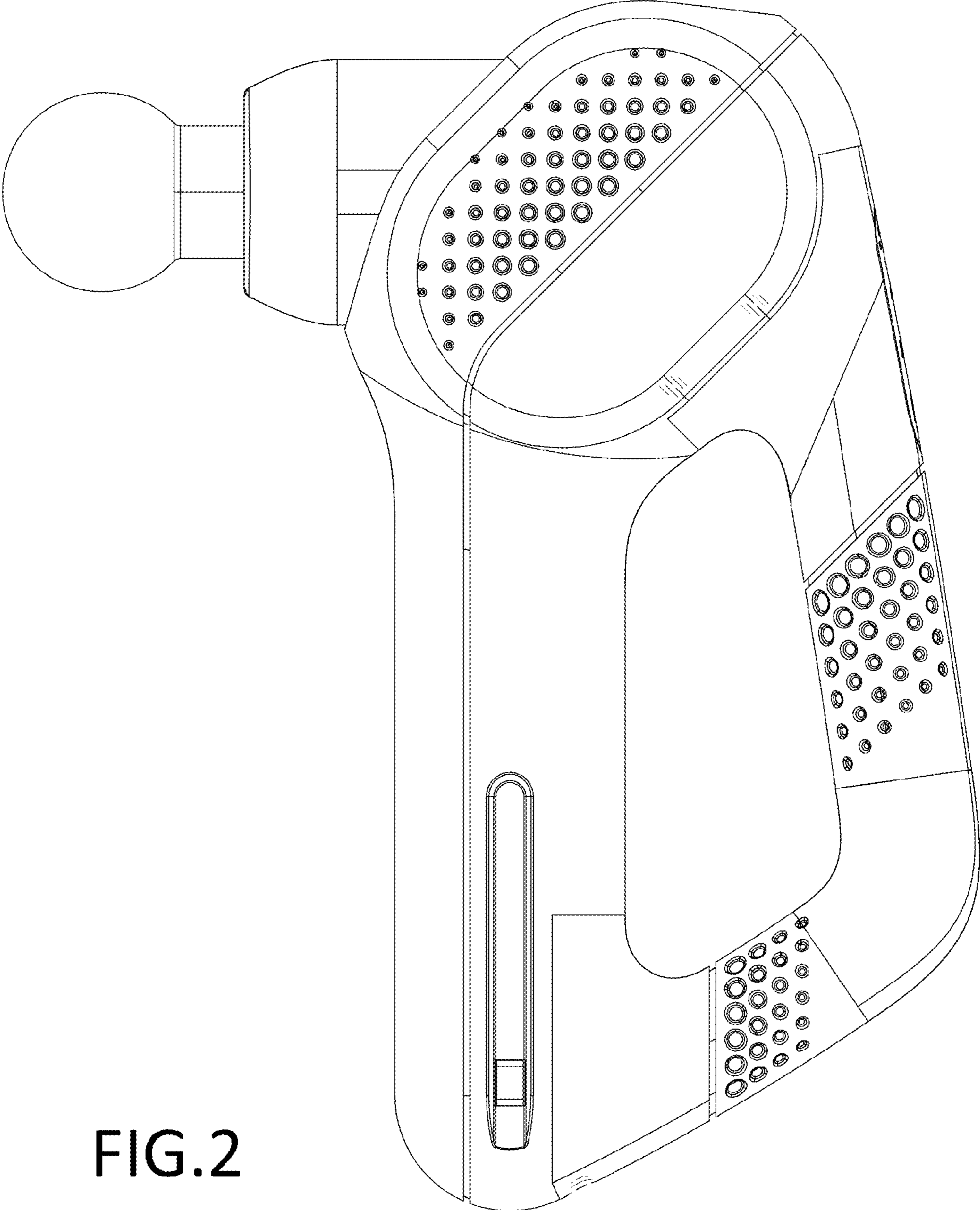

FIG.2

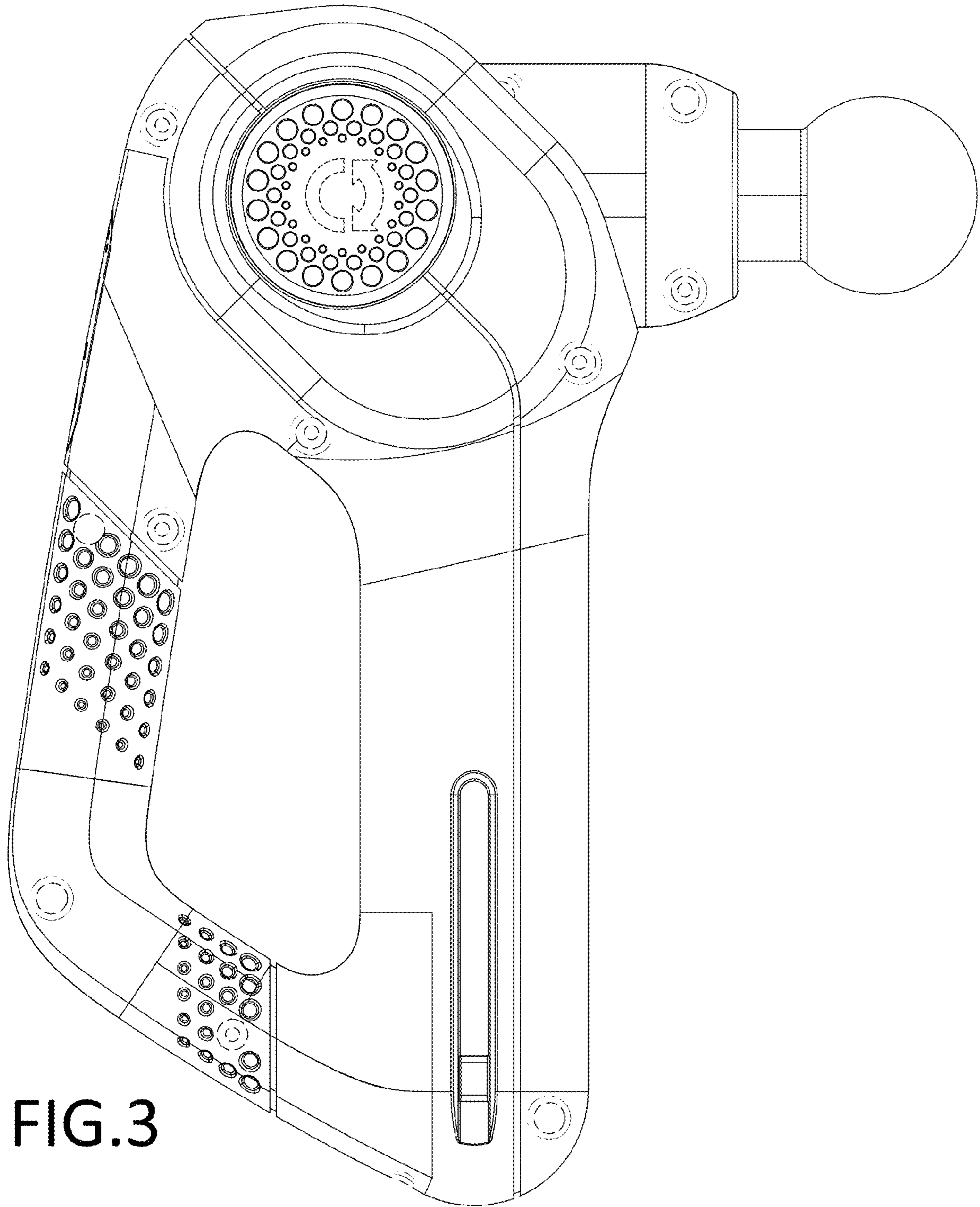

FIG.3

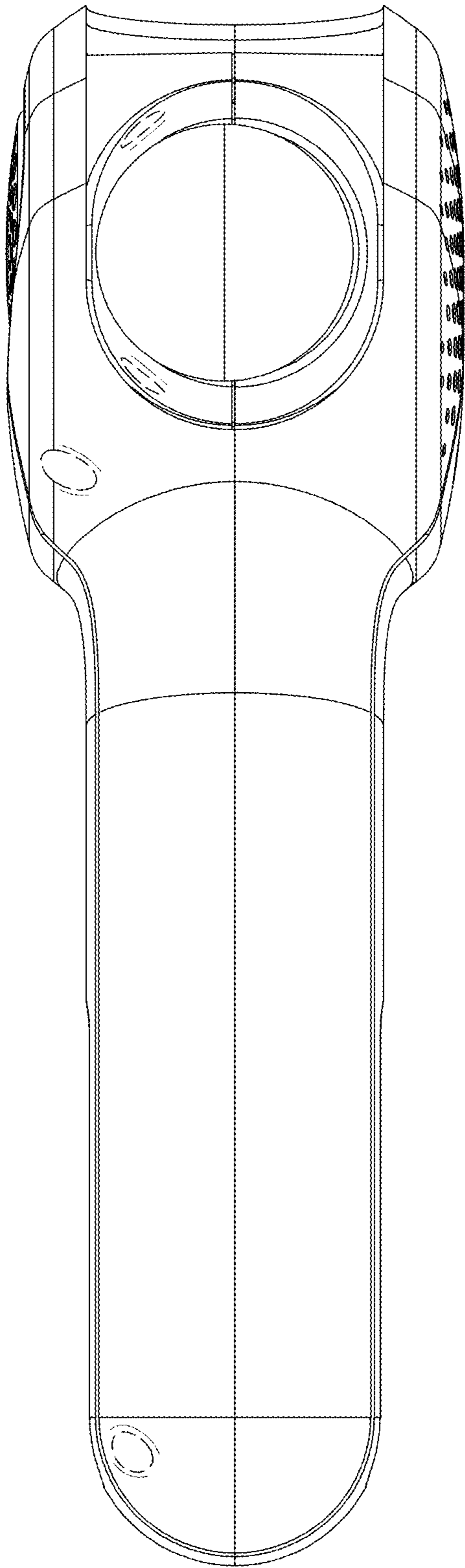

FIG. 4

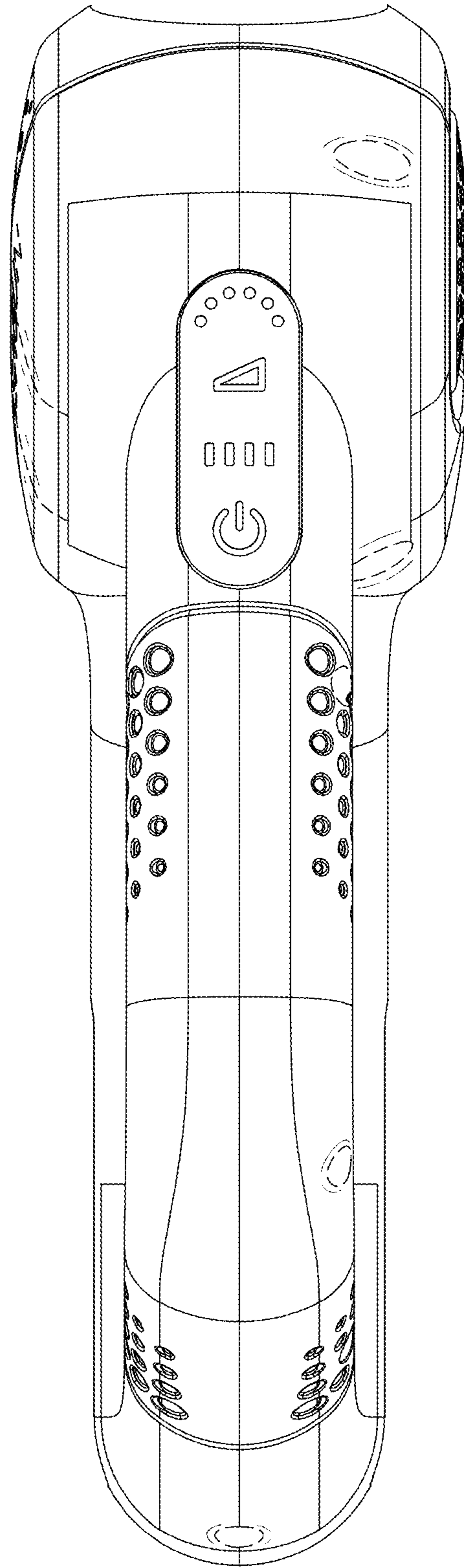

FIG. 5

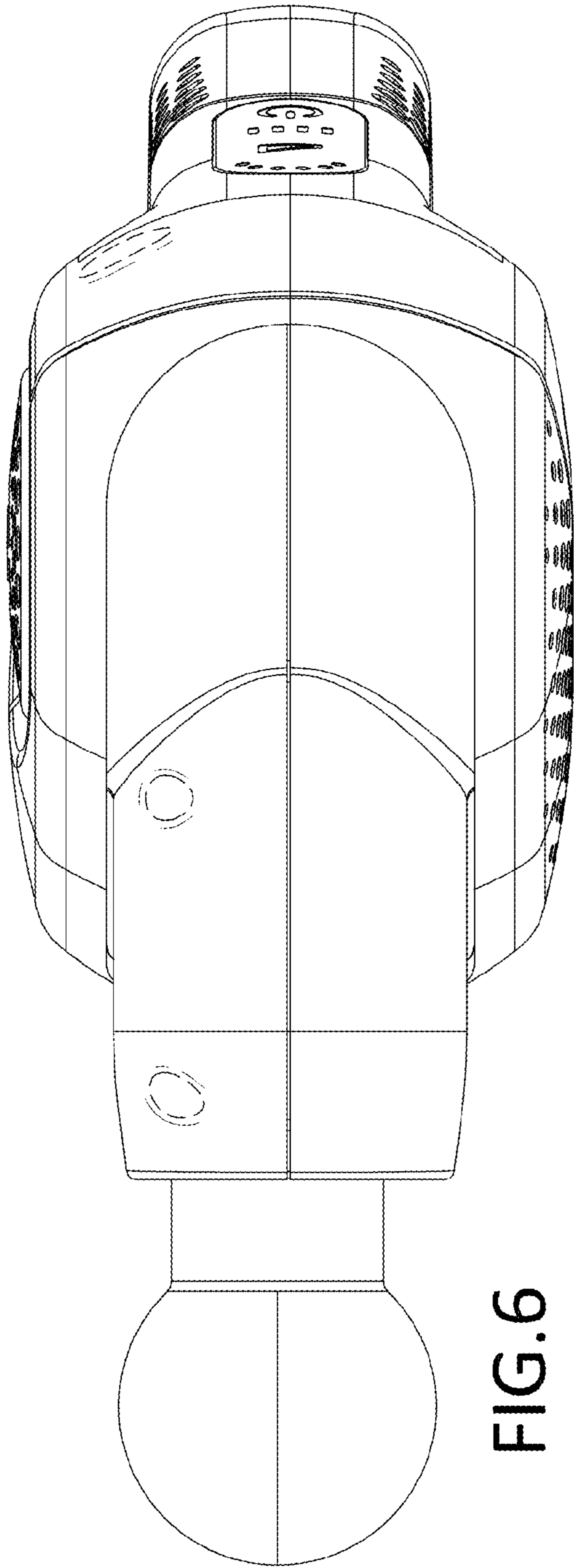

FIG. 6

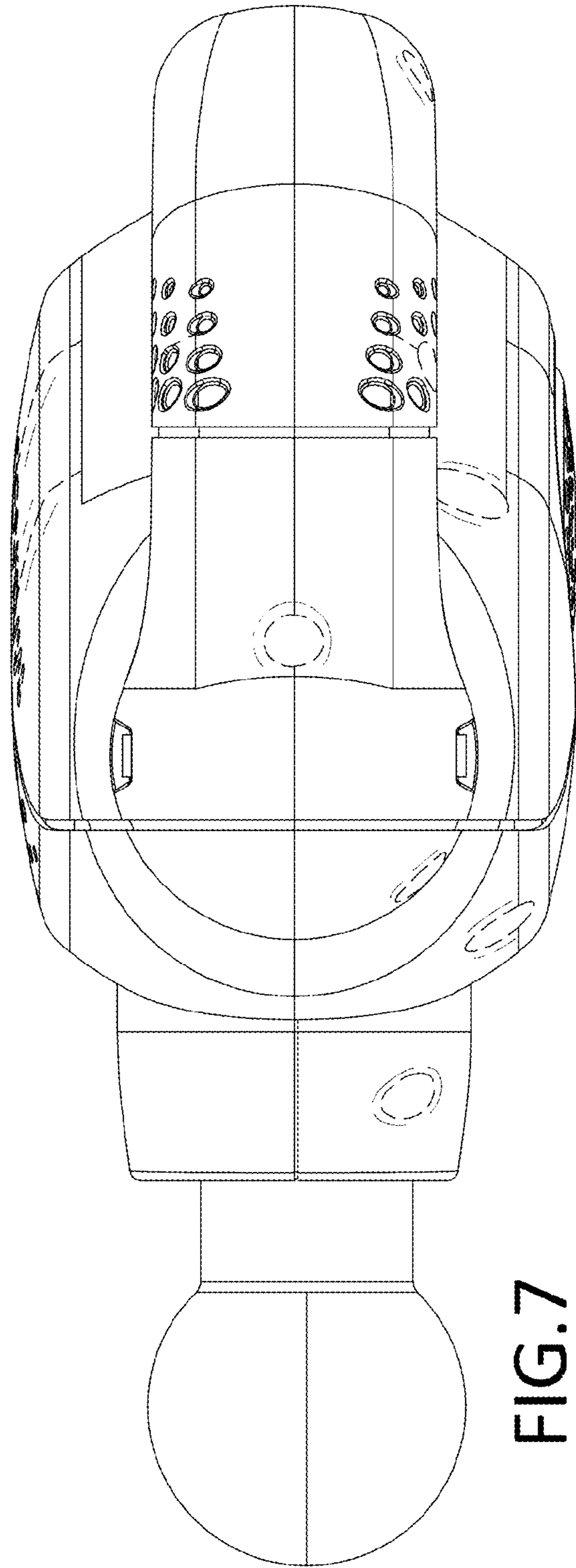

FIG. 7