



US00D983277S

(12) **United States Design Patent**
Yin

(10) **Patent No.:** **US D983,277 S**
(45) **Date of Patent:** **** Apr. 11, 2023**

(54) **ACTIVITY TOY**

- (71) Applicant: **Chengfeng Yin**, Guangdong (CN)
- (72) Inventor: **Chengfeng Yin**, Guangdong (CN)
- (**) Term: **15 Years**
- (21) Appl. No.: **29/838,293**
- (22) Filed: **May 11, 2022**
- (51) **LOC (14) Cl.** **21-01**
- (52) **U.S. Cl.**
USPC **D21/475**
- (58) **Field of Classification Search**
USPC D21/335, 398, 468, 475, 476, 478
(Continued)

(56) **References Cited**

U.S. PATENT DOCUMENTS

- D187,218 S * 2/1960 McHugh 434/258
 - D266,682 S * 10/1982 Airlie D21/517
- (Continued)

OTHER PUBLICATIONS

Esjay Toddler Busy Board, Reviewed and online as early as Aug. 6, 2020 [online], [site visited Dec. 16, 2022]. Available from Internet: <URL: <https://www.amazon.com/dp/B089GHNCSE>> (Year: 2020).*

(Continued)

Primary Examiner — Cynthia M. Chin

(74) *Attorney, Agent, or Firm* — Che-Yang Chen; Law Office of Michael Chen

(57) **CLAIM**

The ornamental design for a activity toy, as shown and described.

DESCRIPTION

FIG. 1 is a perspective view of a portion of the activity toy showing my new design, shown separately for the clarity of illustration;

FIG. 2 is a perspective view thereof from another angle;

FIG. 3 is a front elevational view thereof;

FIG. 4 is a rear elevational view thereof;

FIG. 5 is a left side elevational view thereof;

FIG. 6 is a right side elevational view thereof;

FIG. 7 is a top plan view thereof;

FIG. 8 is a bottom plan view thereof;

FIG. 9 is a perspective view of a first removable portion of the activity toy, shown separately for the clarity of illustration;

FIG. 10 is a perspective view of FIG. 9 from another angle;

FIG. 11 is a front elevational view of FIG. 9;

FIG. 12 is a rear elevational view of FIG. 9;

FIG. 13 is a left side elevational view of FIG. 9;

FIG. 14 is a right side elevational view of FIG. 9;

FIG. 15 is a top plan view of FIG. 9;

FIG. 16 is a bottom plan view of FIG. 9;

FIG. 17 is a perspective view which is a second removable portion of the activity toy, shown separately for the clarity of illustration;

FIG. 18 is a perspective view of FIG. 17 from another angle;

FIG. 19 is a front elevational view of FIG. 17;

FIG. 20 is a rear elevational view of FIG. 17;

FIG. 21 is a left side elevational view of FIG. 17;

FIG. 22 is a right side elevational view of FIG. 17;

FIG. 23 is a top plan view of FIG. 17;

FIG. 24 is a bottom plan view of FIG. 17;

FIG. 25 is a closed perspective view of the assembled activity toy with the first and second removable portions inserted; and,

FIG. 26 is an isometric open view of FIG. 25.

The broken lines shown in the drawings represent portions of the activity toy that form no part of the claimed design.

1 Claim, 26 Drawing Sheets

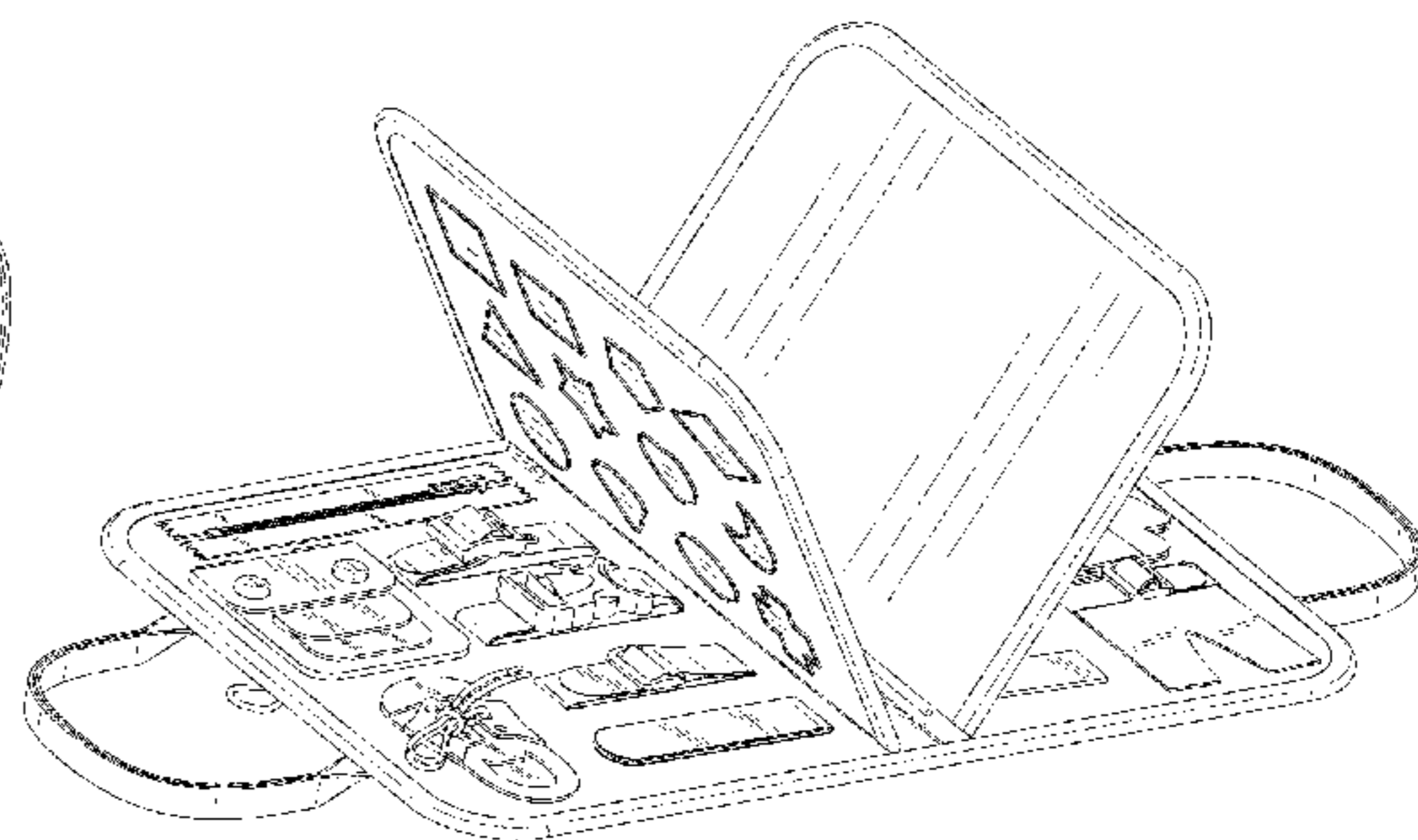
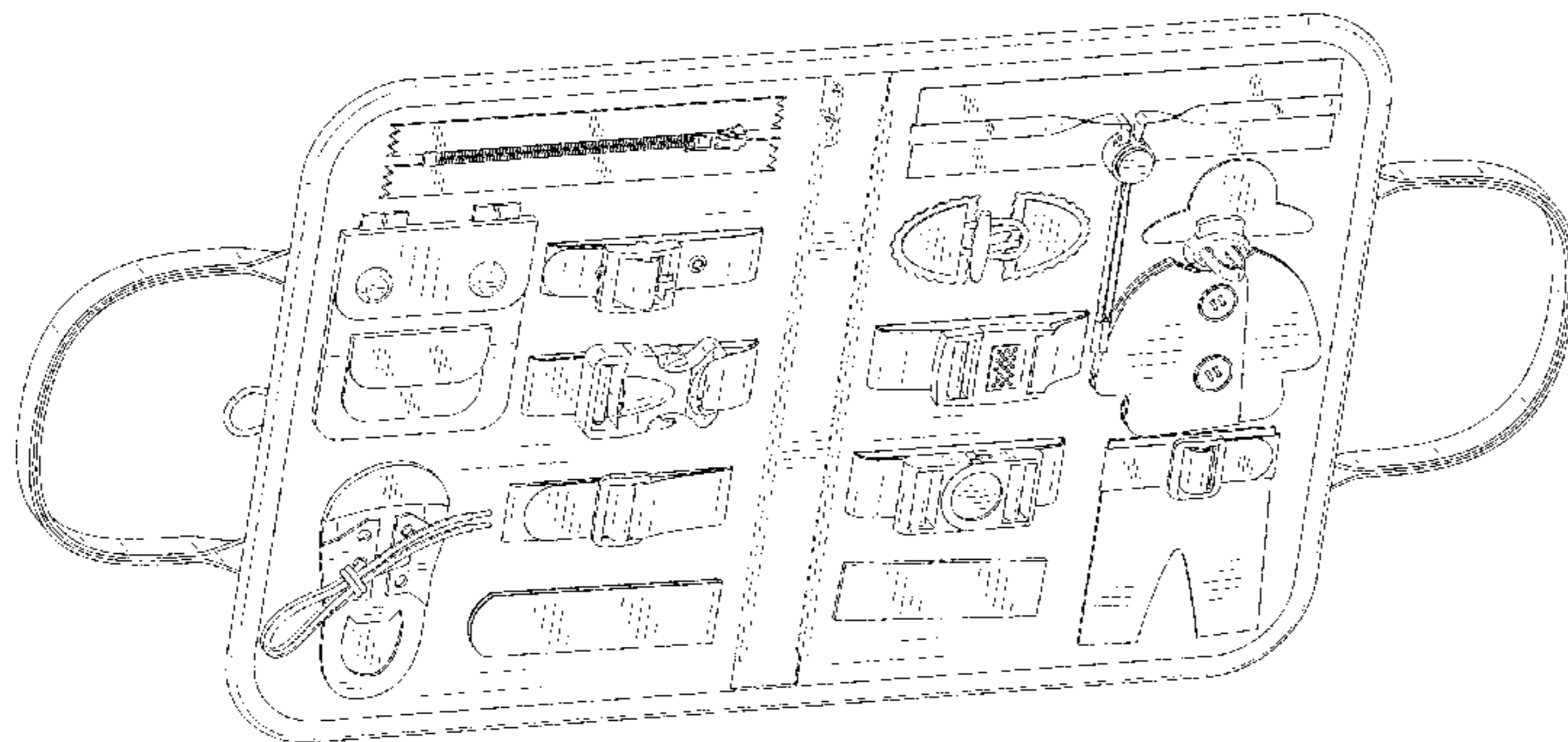

(58) **Field of Classification Search**

CPC A63F 2250/025; A63F 2250/12; A63F
2250/168; A63H 33/00; A63H 33/30;
A63H 33/38

See application file for complete search history.

(56) **References Cited**

U.S. PATENT DOCUMENTS

D281,514 S 11/1985 Pryor
5,709,582 A * 1/1998 O'Donnell A63H 33/006
446/227
D510,393 S * 10/2005 Trufant D3/282
D800,833 S * 10/2017 Kalia D21/478
11,000,775 B1 * 5/2021 Riegelman A63H 33/38
D960,991 S * 8/2022 Rees D21/335

OTHER PUBLICATIONS

LearnToy Store Toddler Busy Board, Reviewed and online as early as Oct. 23, 2021 [online], [site visited Dec. 16, 2022]. Available from Internet: <URL:https://www.amazon.com/dp/B09F9P8NSC/> (Year: 2021).*

Varano Busy Board Montessori Toy, Reviewed and online as early as Jul. 23, 2021 [online], [site visited Dec. 16, 2022]. Available from Internet: <URL:https://www.amazon.com/dp/B098F6N9YS/> (Year: 2021).*

* cited by examiner

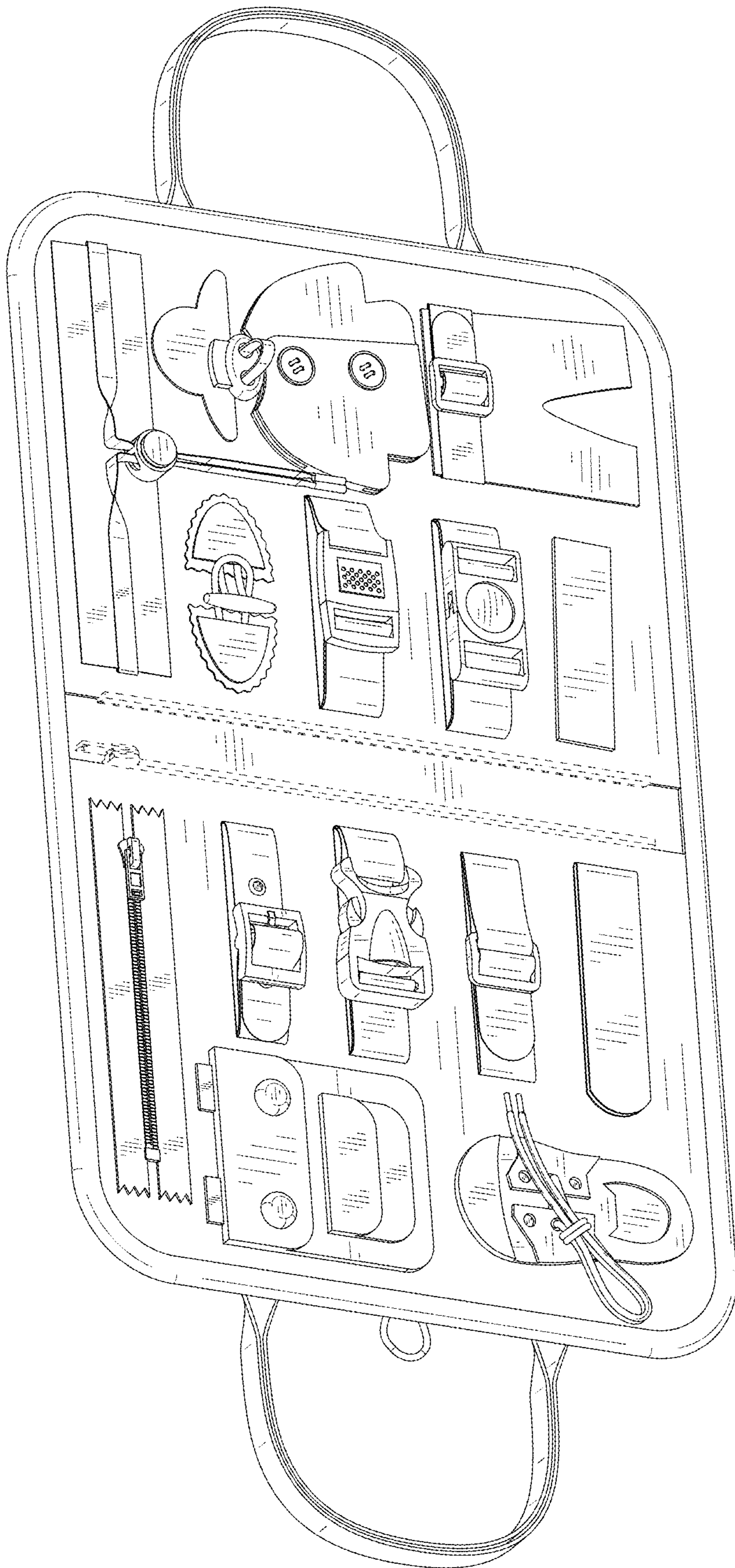

FIG. 1

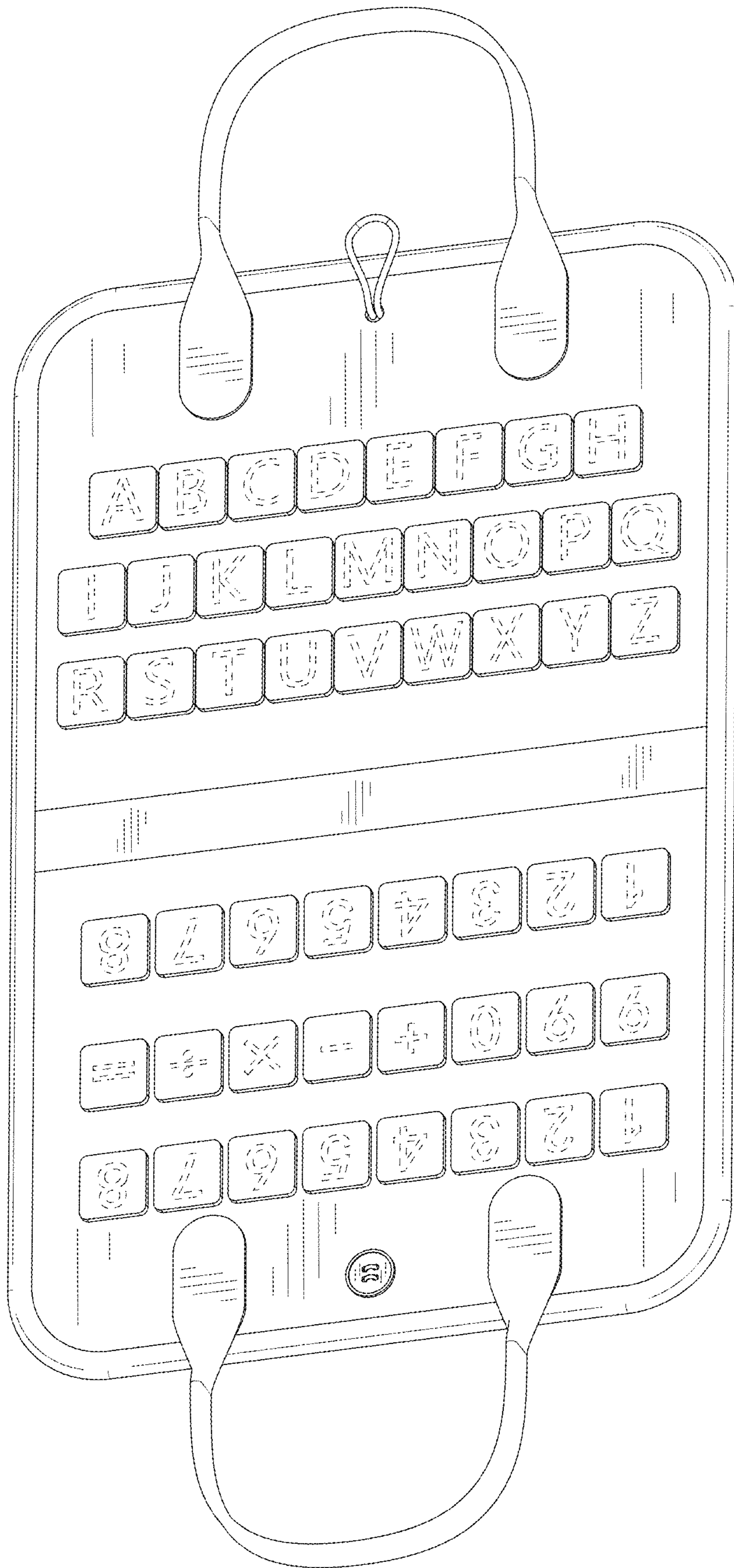

FIG. 2

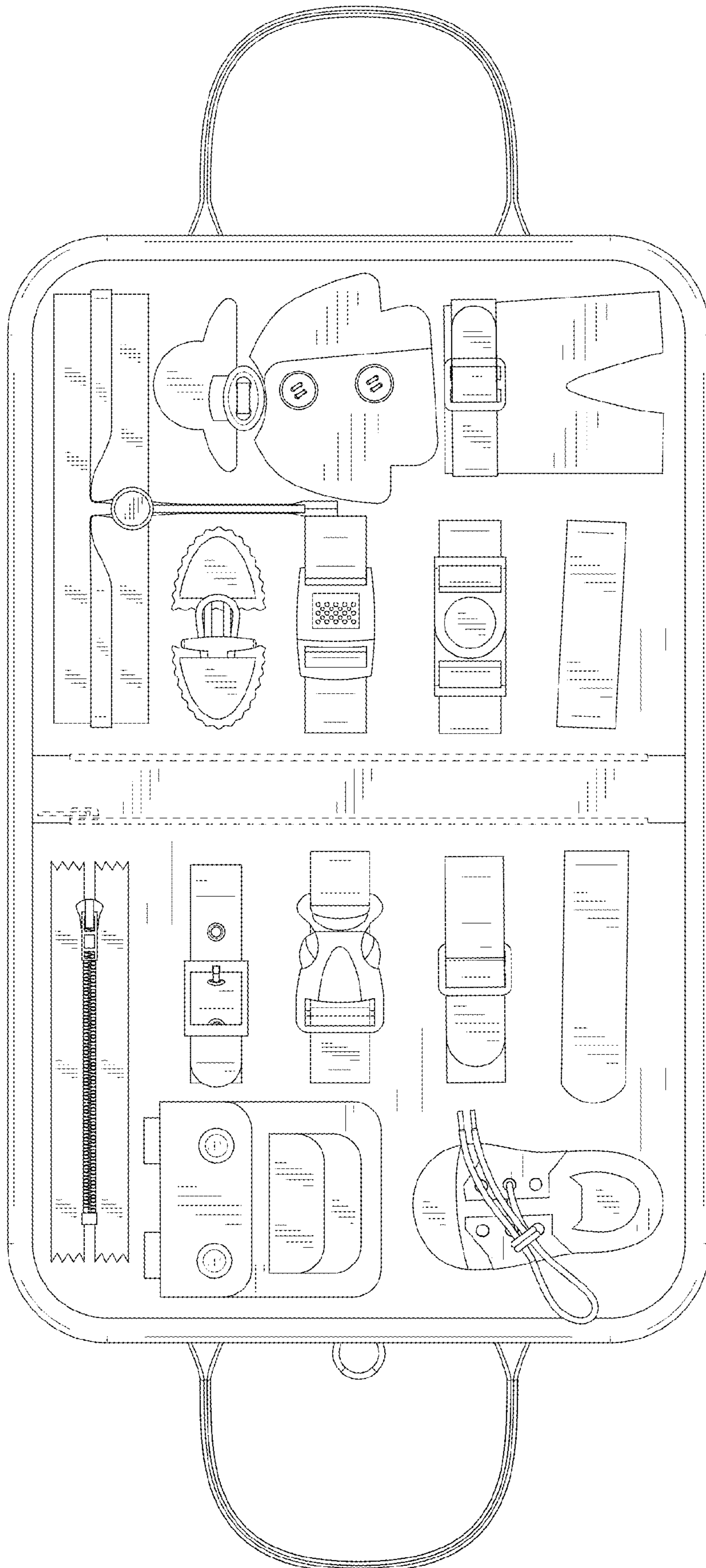

FIG. 3

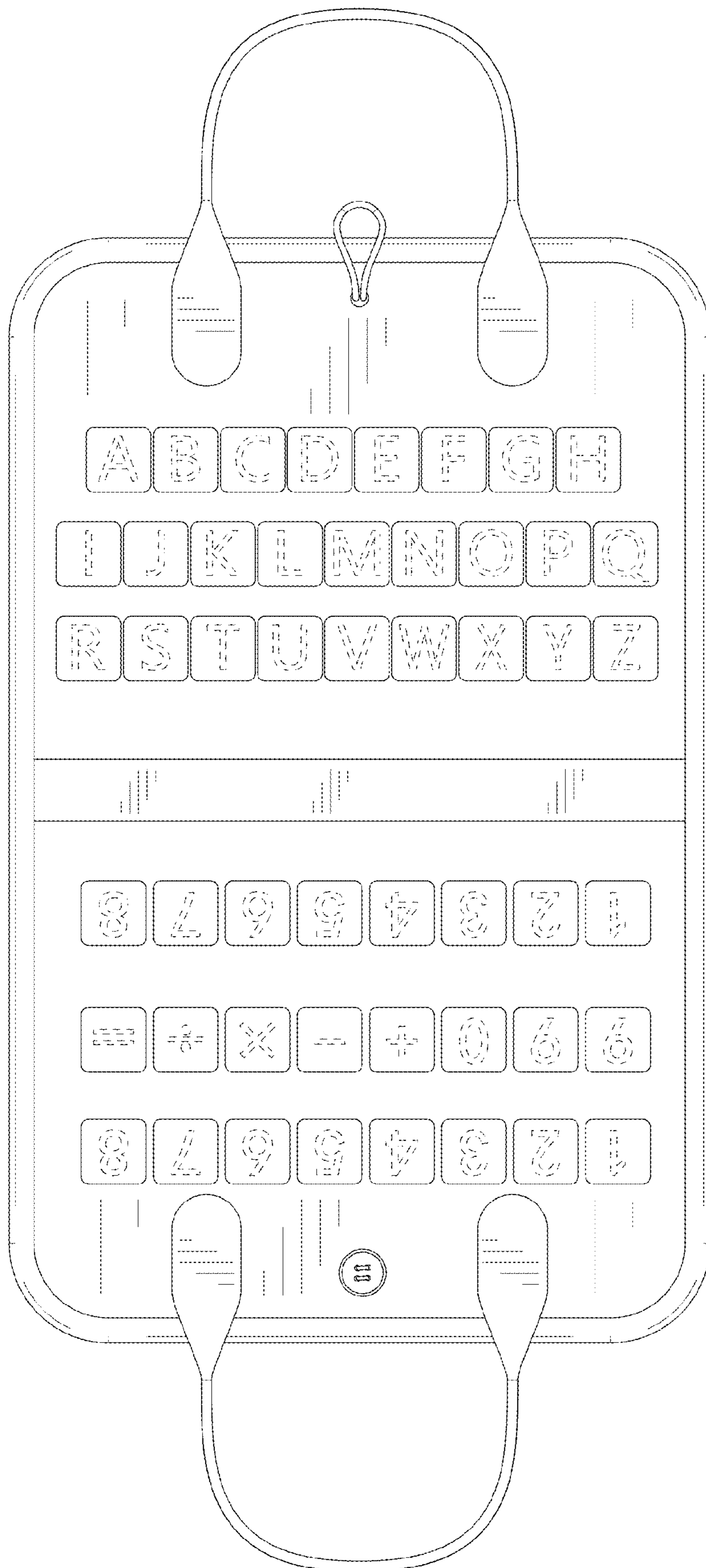

FIG. 4

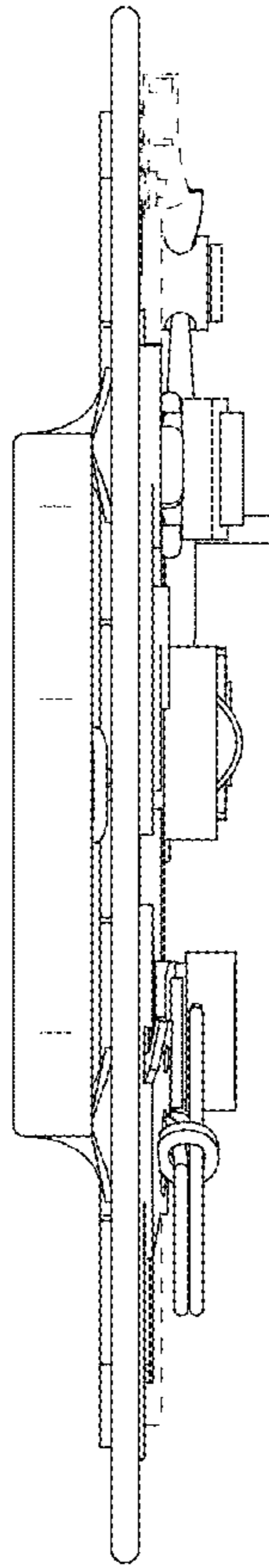

FIG. 5

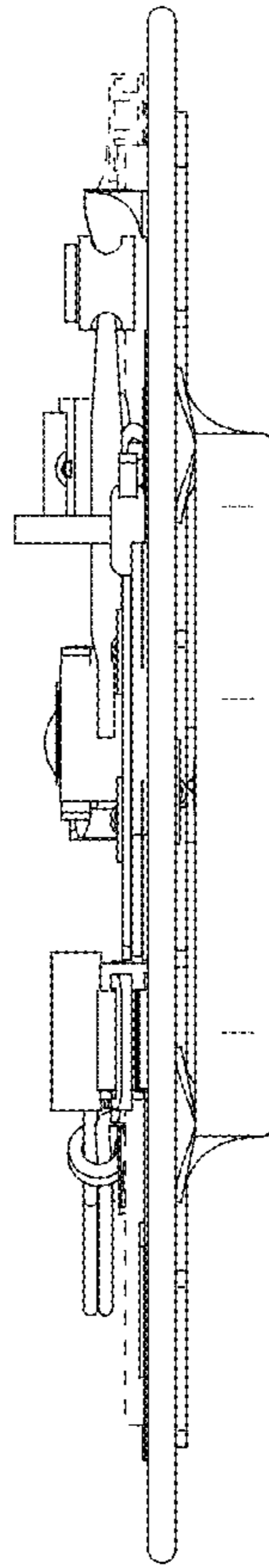

FIG. 6

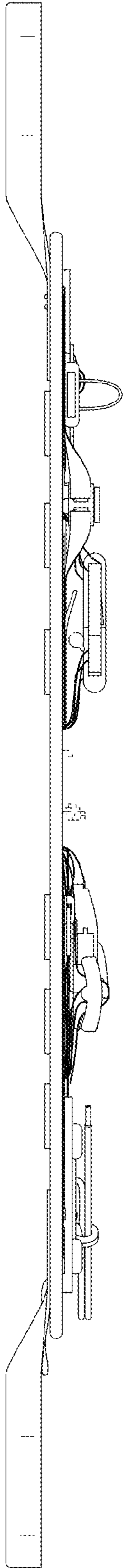

FIG. 7

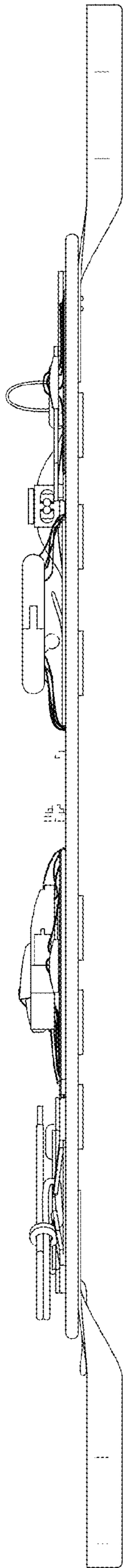

FIG. 8

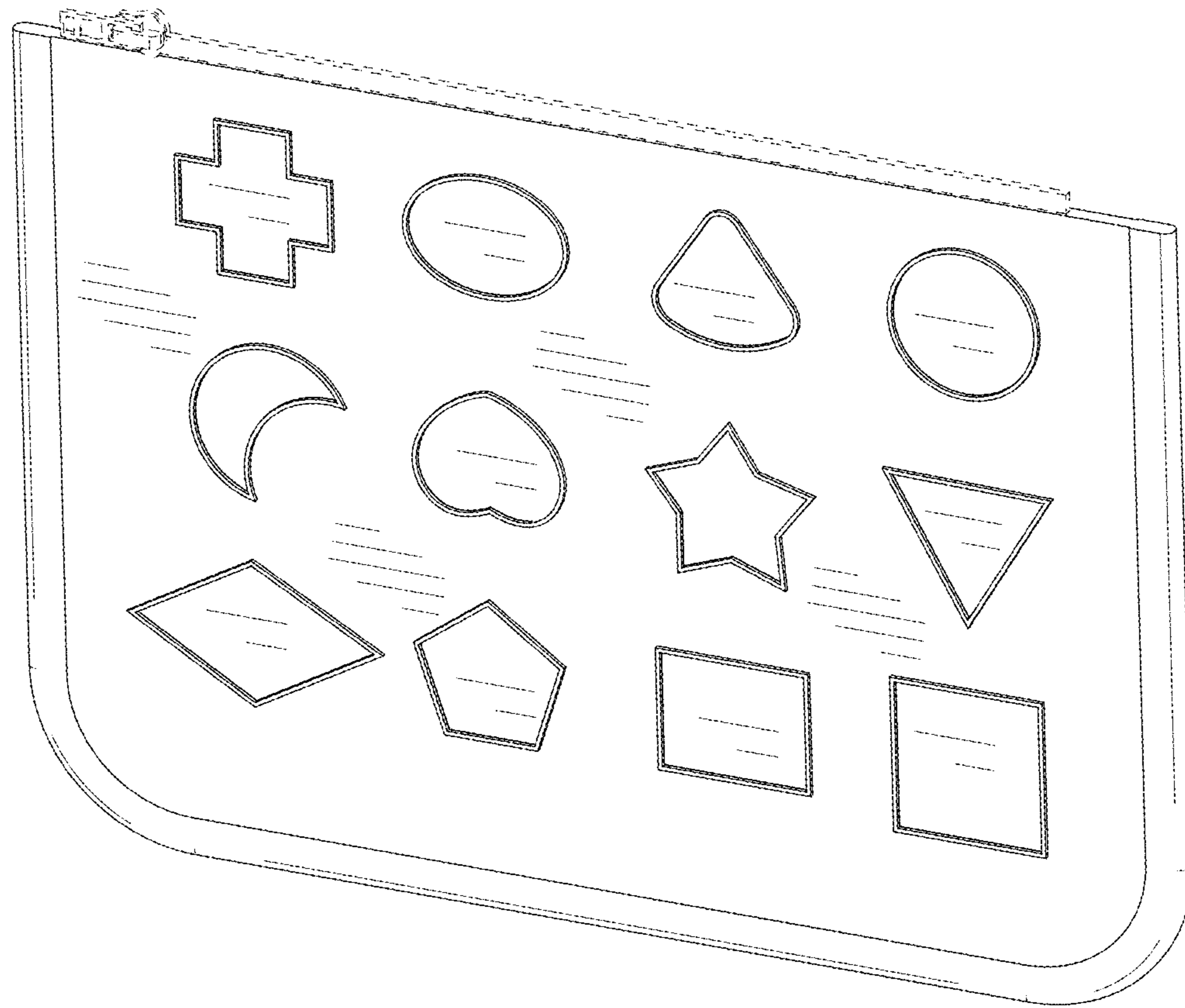

FIG. 9

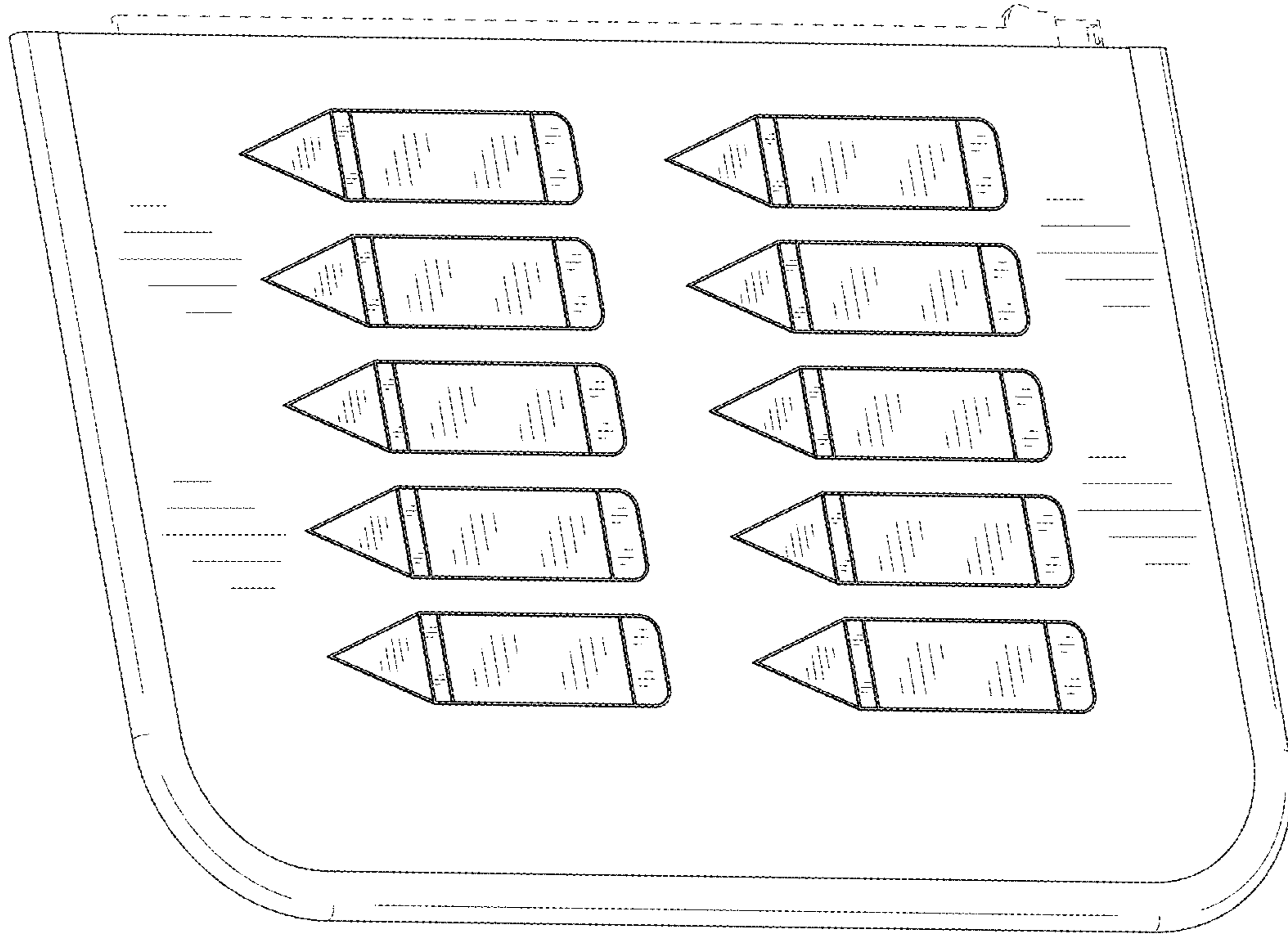

FIG. 10

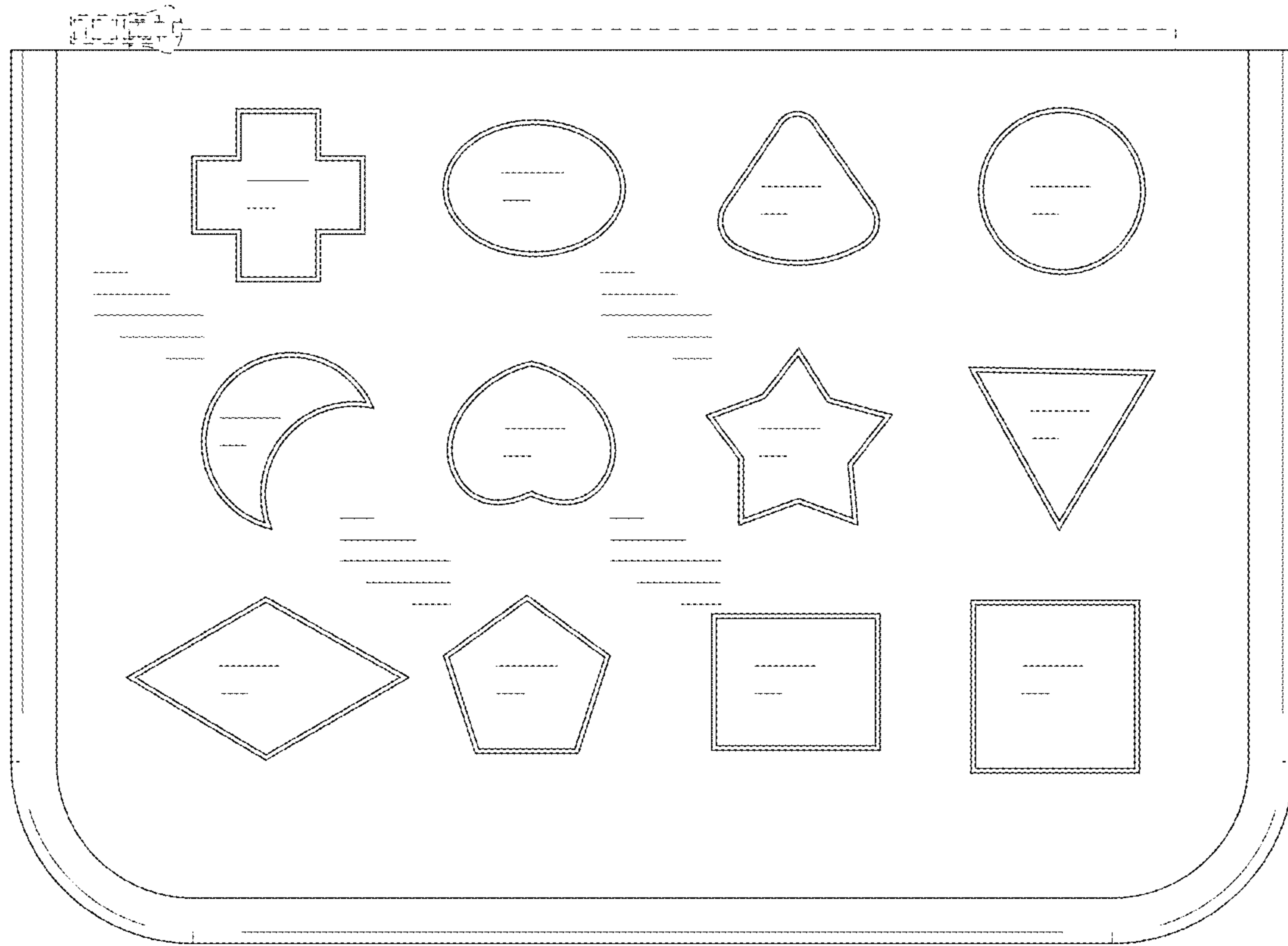

FIG. 11

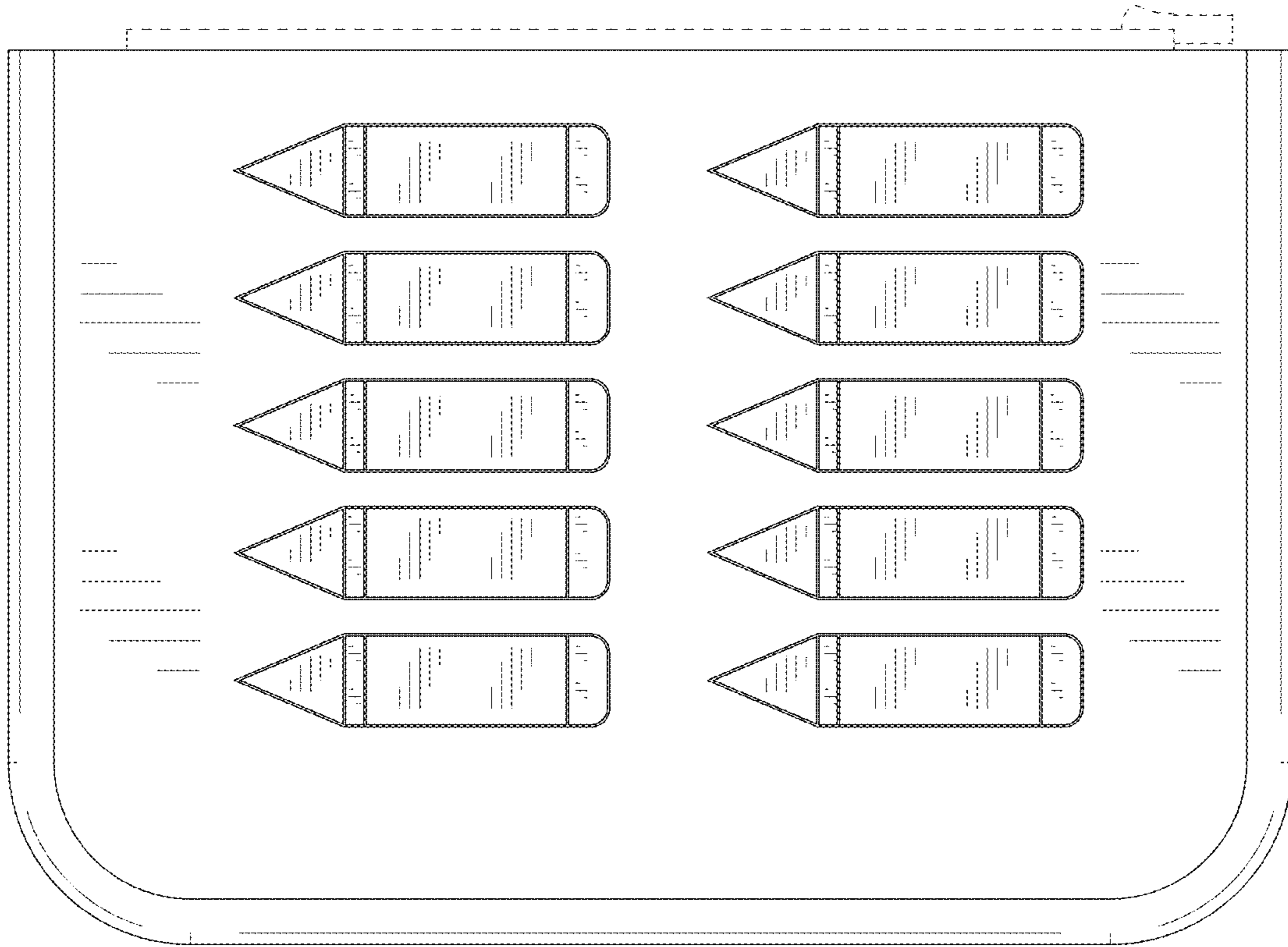

FIG. 12

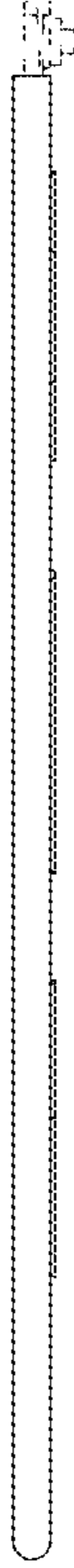

FIG. 13

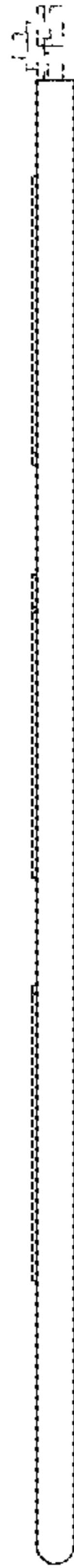

FIG. 14



FIG. 15

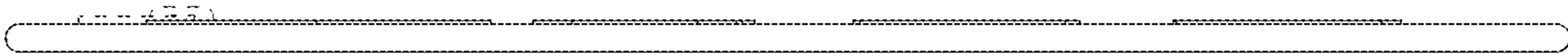

FIG. 16

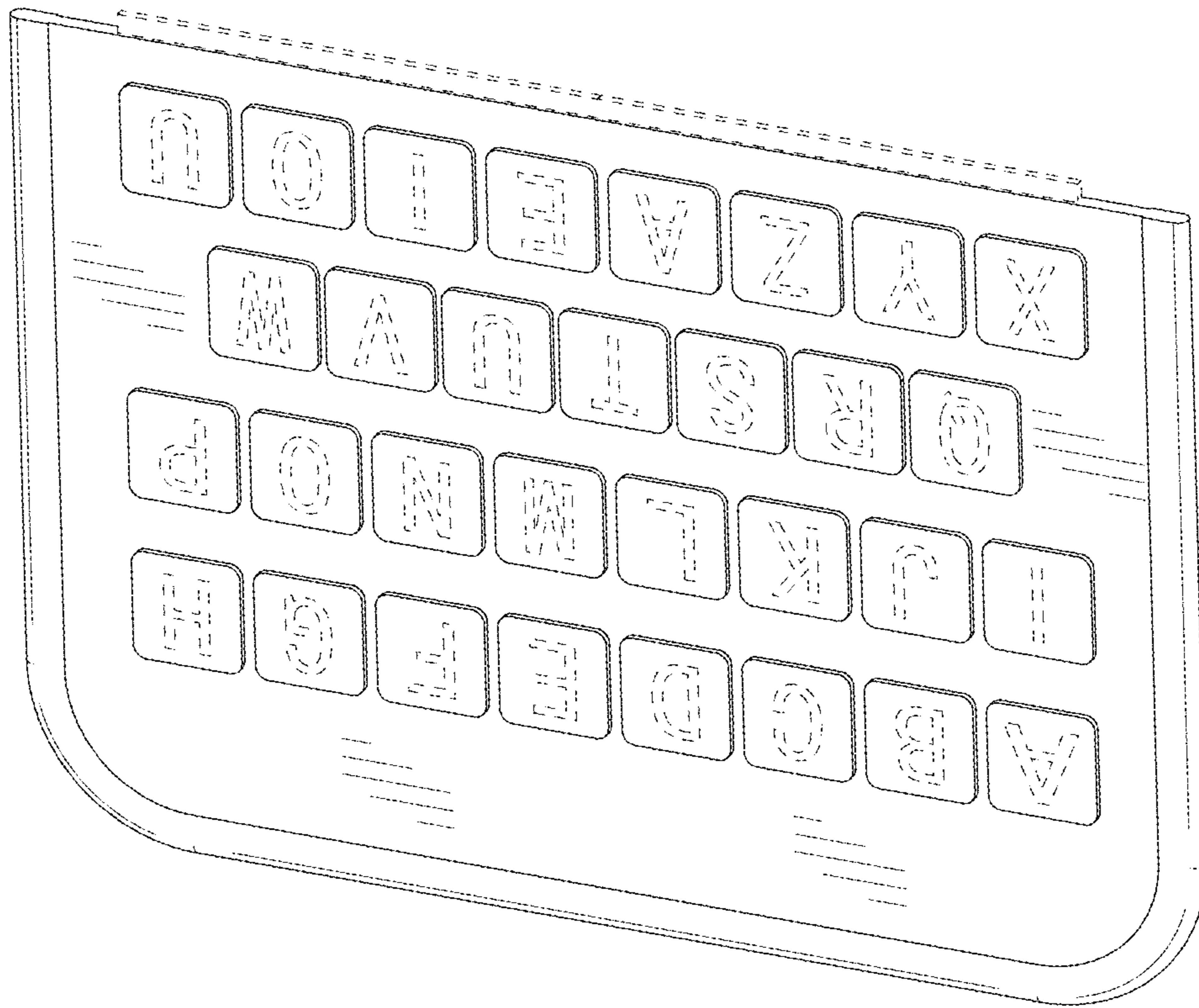

FIG. 17

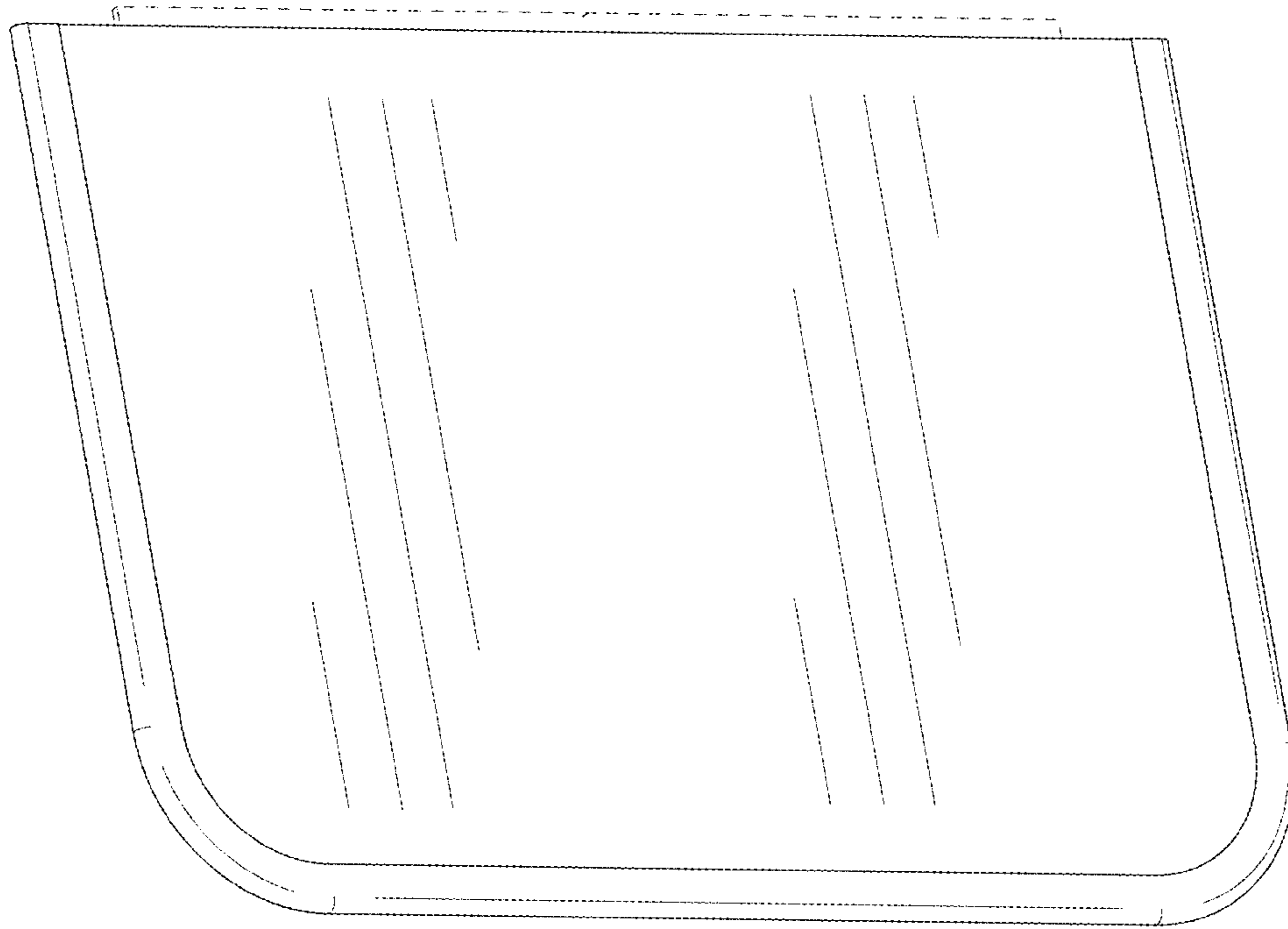

FIG. 18

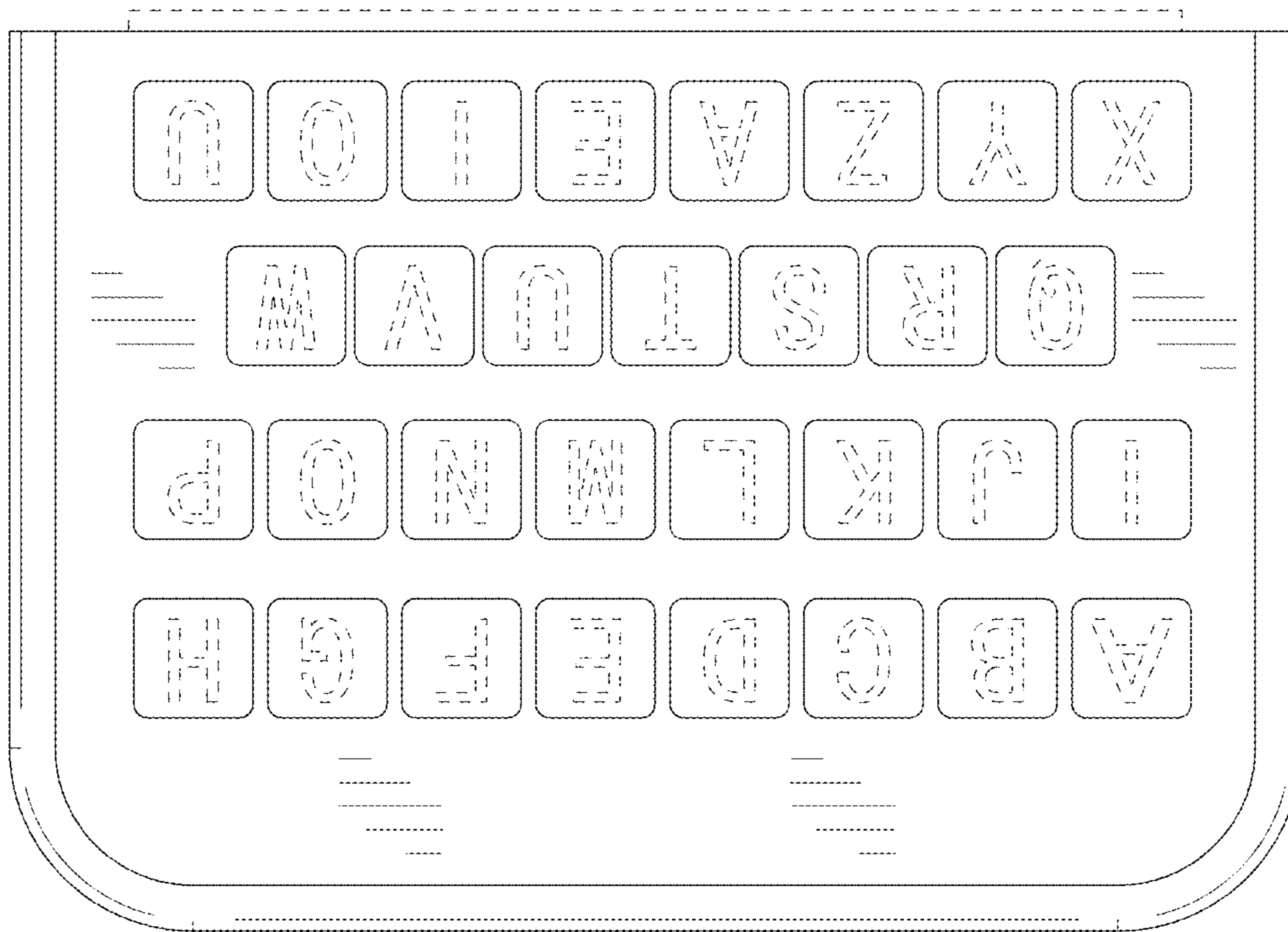

FIG. 19

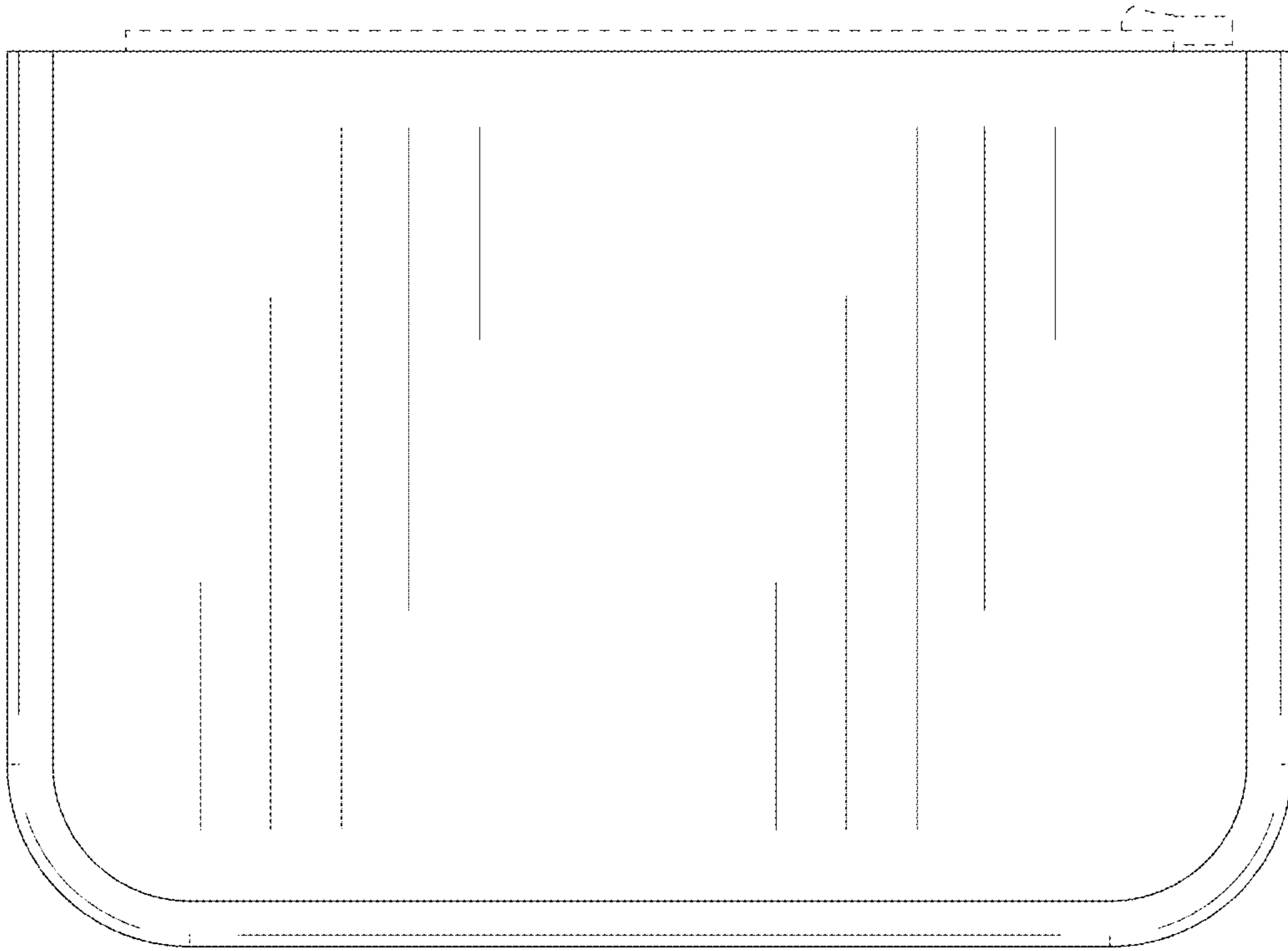

FIG. 20

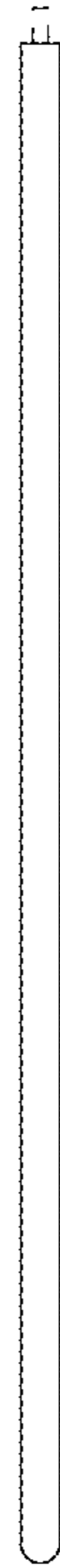

FIG. 21

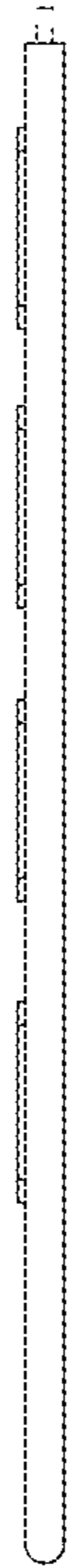

FIG. 22

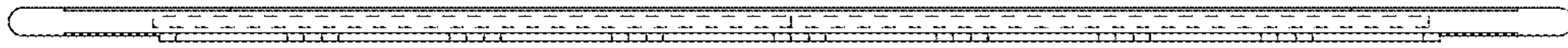

FIG. 23

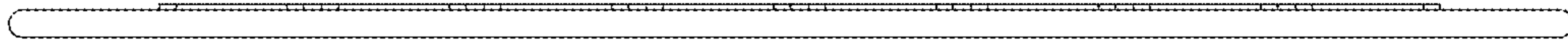

FIG. 24

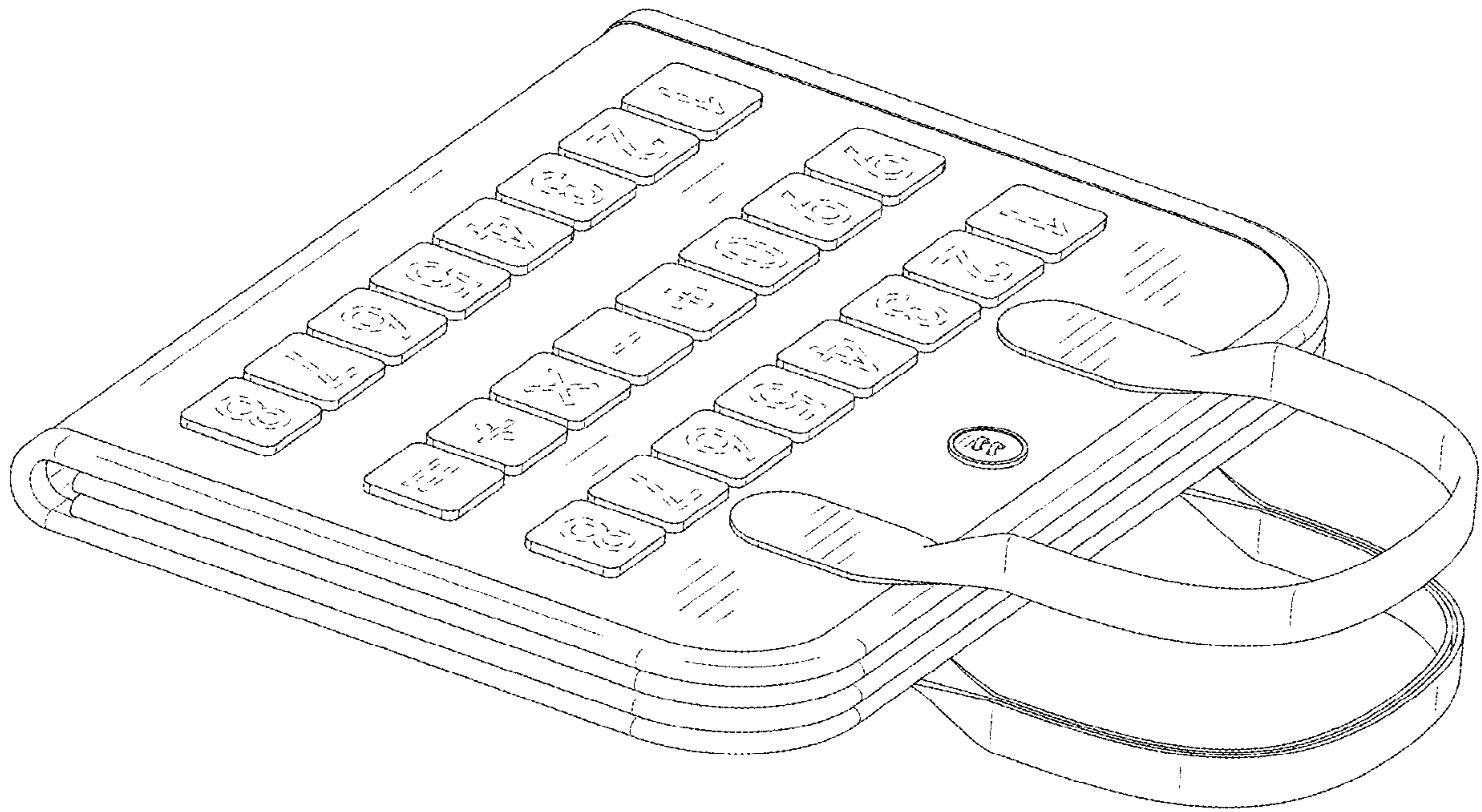

FIG. 25

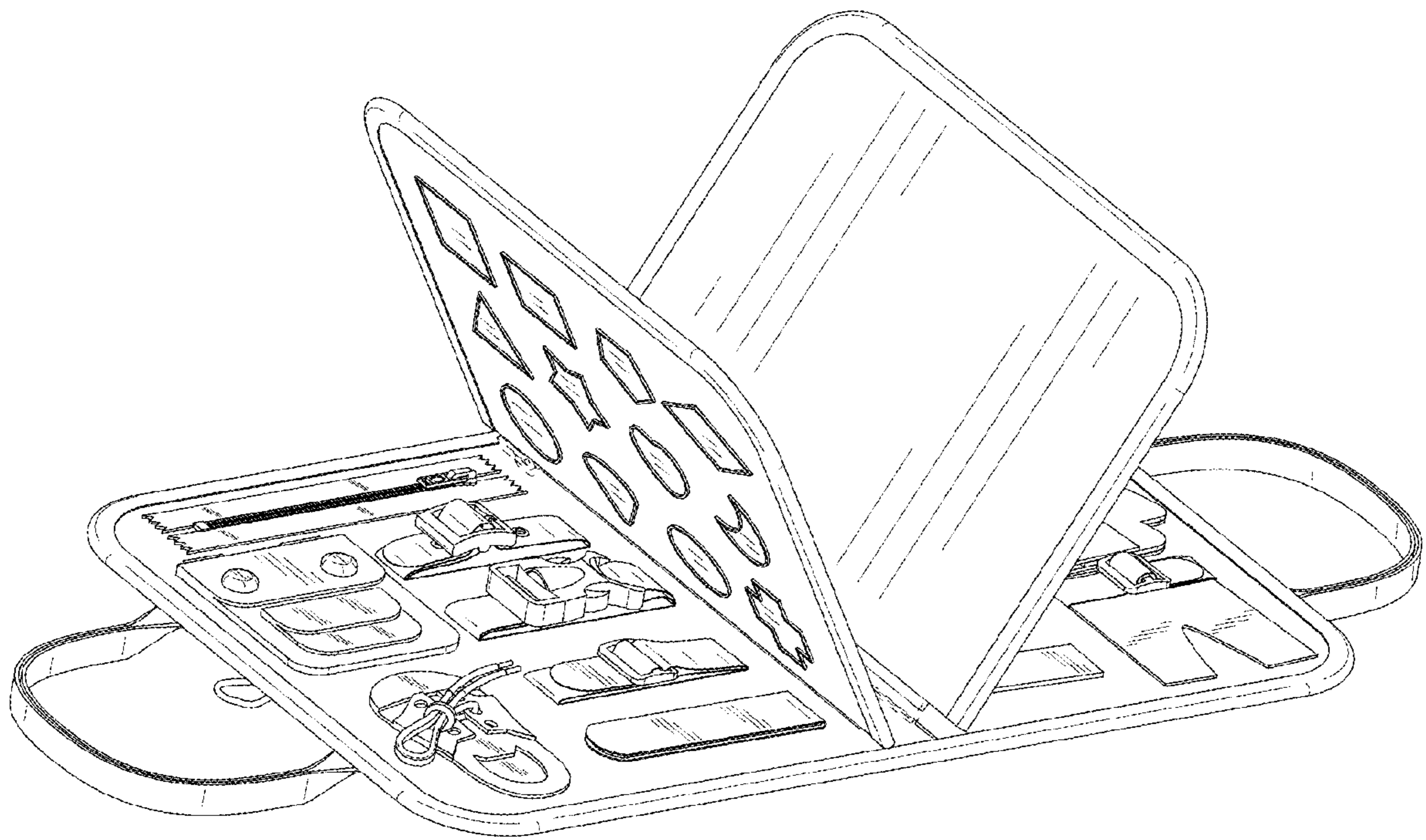

FIG. 26