



US00D983230S

(12) **United States Design Patent** (10) **Patent No.:** **US D983,230 S**
Hollifield (45) **Date of Patent:** **** Apr. 11, 2023**

(54) **LAWNMOWER BLADE**
(71) Applicant: **Timothy Hollifield**, Danielsville, GA (US)
(72) Inventor: **Timothy Hollifield**, Danielsville, GA (US)
(**) Term: **15 Years**
(21) Appl. No.: **29/831,488**
(22) Filed: **Mar. 21, 2022**

Related U.S. Application Data

(62) Division of application No. 29/740,753, filed on Jul. 7, 2020, now Pat. No. Des. 950,610.

(51) **LOC (14) Cl.** **15-03**
(52) **U.S. Cl.**
USPC **D15/17**

(58) **Field of Classification Search**
USPC D15/14, 17, 28; D8/4-12, 16, 20
CPC A01D 34/67; A01D 34/69; A01D 34/4116;
A01D 34/4168; A01D 34/47; A01D 34/53;
A01D 34/005; A01D 34/03; A01D 34/412;
A01D 34/416; A01D 34/4165; A01D 34/00;
A01D 34/43; A01D 34/63; A01D 34/661;
A01D 34/664; A01D 34/73; A01D 34/006;
A01D 34/64; A01D 34/82; A01D 34/001;
A01D 34/008; A01D 34/828; A01D 34/74;
A01D 34/78; A01D 34/824; A01D 2101/00;
A01D 43/063; A01D 43/077; A01D 43/14;
A01D 42/005; A01D 42/04; Y10S 56/17;
Y10S 56/20

See application file for complete search history.

(56) **References Cited**
U.S. PATENT DOCUMENTS

3,343,350 A * 9/1967 Freedlander A01D 34/63 56/295
4,250,621 A * 2/1981 Houle A01D 34/73 56/295

4,302,878 A * 12/1981 Bonforte A01D 34/73 56/295
D268,640 S * 4/1983 Bonforte D8/8
D463,804 S * 10/2002 Porter D15/11
D502,185 S * 2/2005 Byrne D15/17
D523,028 S * 6/2006 Fitzpatrick D15/29
D524,827 S * 7/2006 Byrne D8/8
D574,860 S * 8/2008 Potts D15/17
D577,372 S * 9/2008 Hung D15/17
D656,519 S * 3/2012 Funnell D15/17
D675,073 S * 1/2013 Milburn D8/8
D745,061 S * 12/2015 DeLeon D15/17
D756,724 S * 5/2016 Gripske D8/8
D774,556 S * 12/2016 Gentile D15/17
D778,960 S * 2/2017 Manzon D15/17
D902,262 S * 11/2020 Hoover D15/17
D950,610 S * 5/2022 Hollifield D15/17

* cited by examiner

Primary Examiner — Mark A Goodwin
(74) *Attorney, Agent, or Firm* — Smith Tempel Blaha LLC; Matthew T. Hoots

(57) **CLAIM**

The ornamental design for a lawnmower blade, as shown and described.

DESCRIPTION

FIG. 1 is a top perspective view of a lawnmower blade according to the present invention;
FIG. 2 is a top view thereof;
FIG. 3 is a bottom view thereof;
FIG. 4 is a right side view thereof;
FIG. 5 is a left side view thereof;
FIG. 6 is a back view thereof; and,
FIG. 7 is a front view thereof.
The broken lines in the drawings of the lawnmower blade form no part of the claimed design.

1 Claim, 5 Drawing Sheets

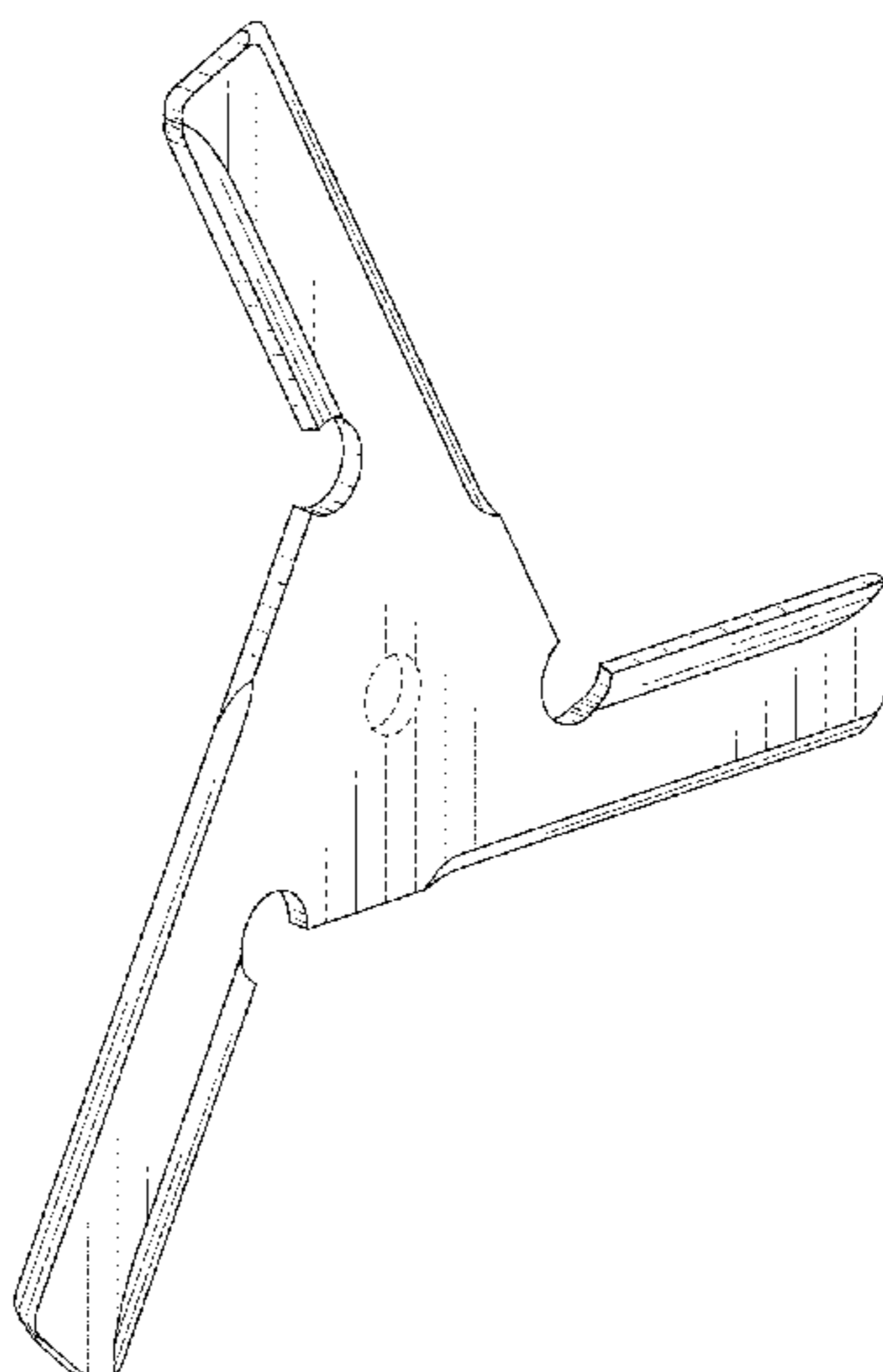

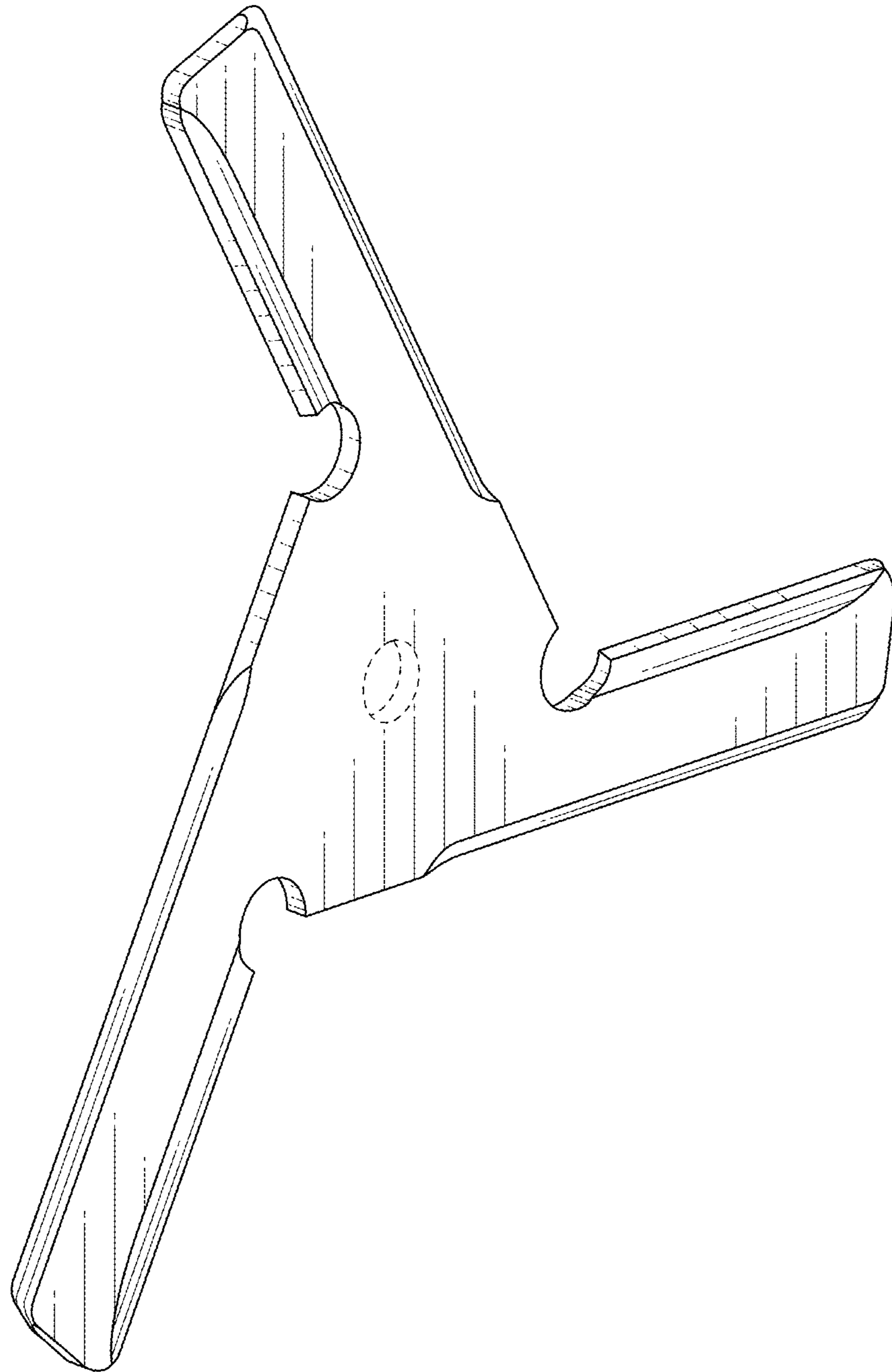

FIG. 1

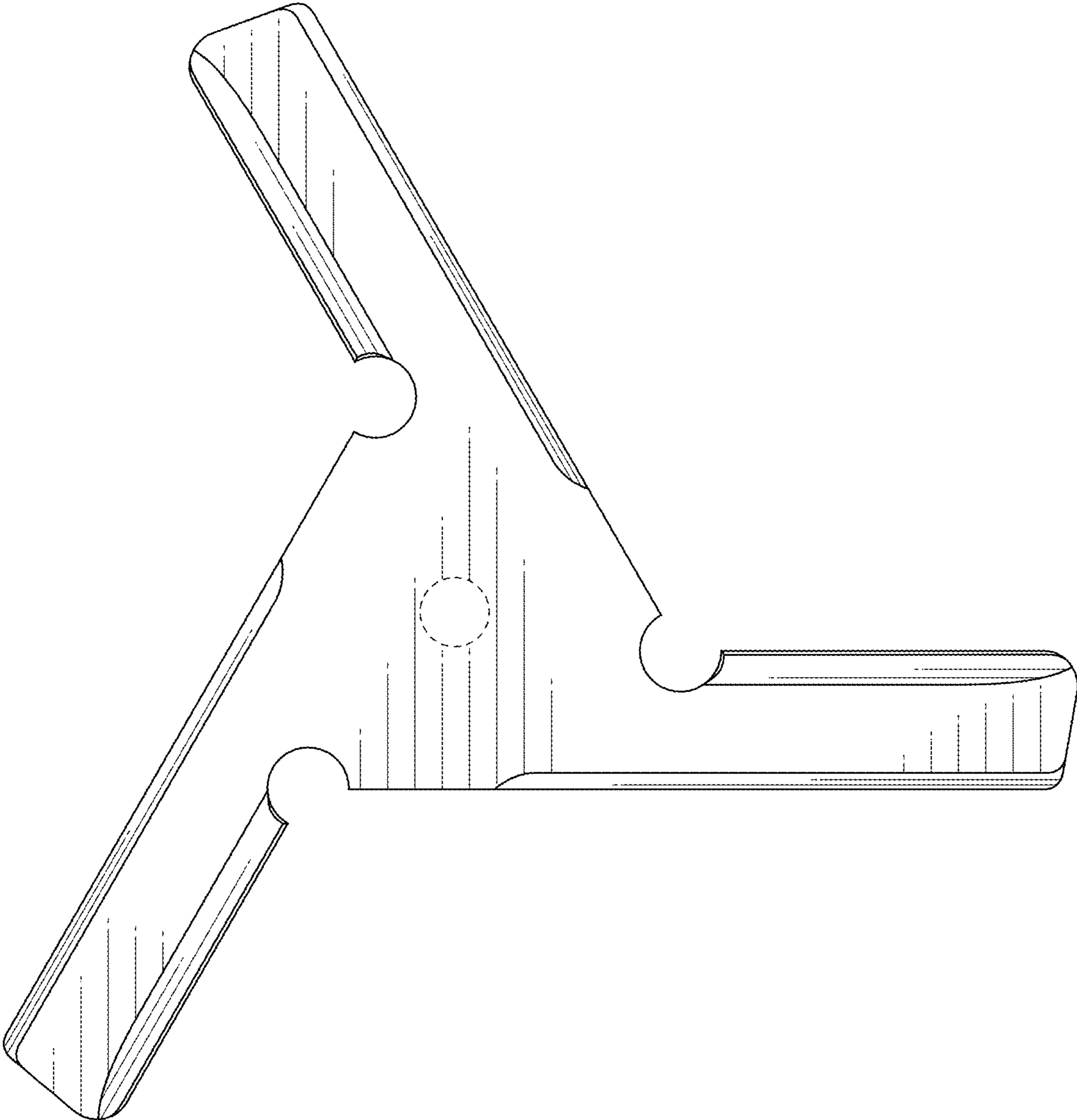

FIG. 2

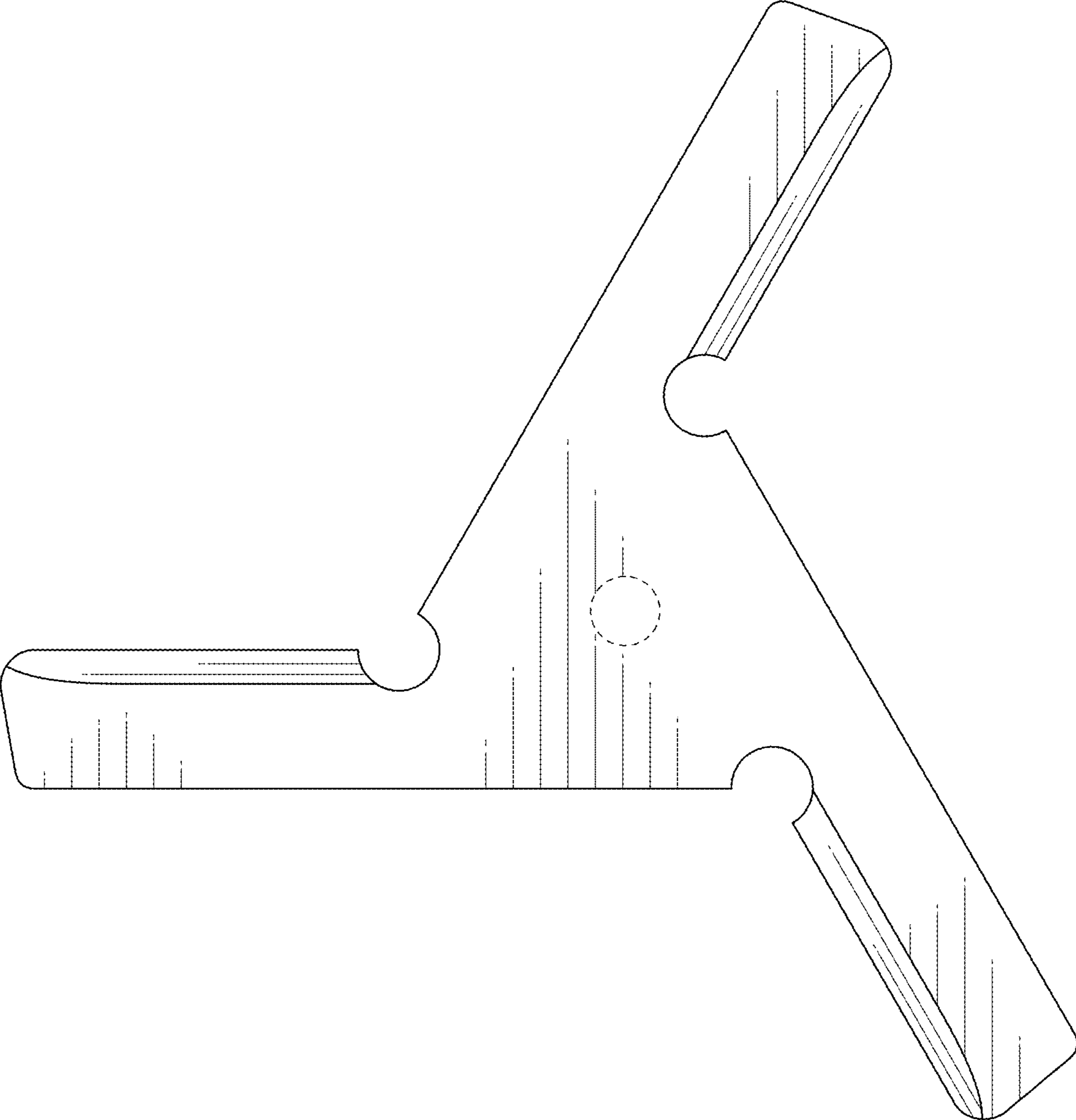

FIG. 3



FIG. 4

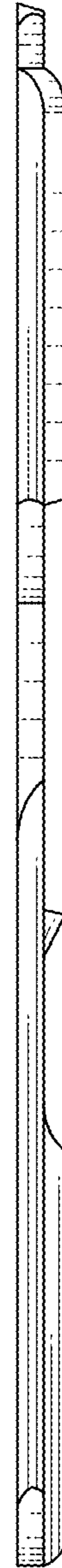

FIG. 5

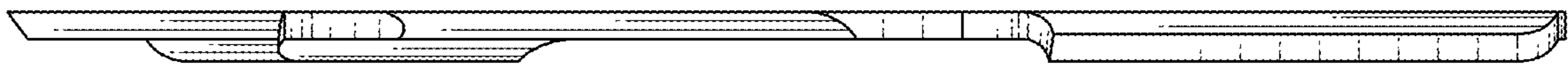

FIG. 6

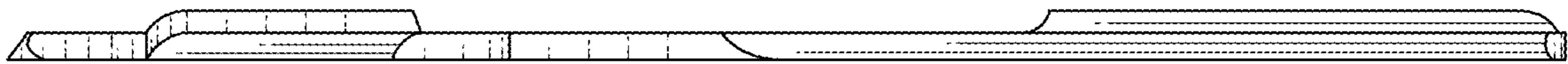

FIG. 7