



US00D982762S

(12) **United States Design Patent** (10) **Patent No.:** **US D982,762 S**
Rao et al. (45) **Date of Patent:** **** Apr. 4, 2023**

(54) **ANALYTE SENSOR INSERTER** 4,129,128 A 12/1978 McFarlane
4,178,916 A 12/1979 McNamara
(71) Applicant: **ABBOTT DIABETES CARE INC.**, Alameda, CA (US) 4,327,725 A 5/1982 Cortese et al.
(Continued)

(72) Inventors: **Vivek Rao**, Alameda, CA (US); **Steven T. Mitchell**, Pleasant Hill, CA (US); **Matthew Simmons**, Pleasanton, CA (US)

FOREIGN PATENT DOCUMENTS

CN 1202872 5/2005
DE 4401400 7/1995
(Continued)

(73) Assignee: **ABBOTT DIABETES CARE INC.**, Alameda, CA (US)

OTHER PUBLICATIONS

(**) Term: **15 Years**

“Freestyle Libre 3: The Best CGM? | My Experience After 6 Weeks” posted by user Type One Talks. Youtube. Posting date: Nov. 7, 2021. Retrieval date: Oct. 14, 2022. Retrieved from internet: <https://www.youtube.com/watch?v=UU6CRYiAwIY> (Year: 2021).*

(21) Appl. No.: **29/841,976**

(22) Filed: **Jun. 9, 2022**

Primary Examiner — Daniel J Domino

Assistant Examiner — Lee D. Starr

Related U.S. Application Data

(63) Continuation of application No. 29/763,191, filed on Dec. 21, 2020.

(74) *Attorney, Agent, or Firm* — McAndrews Held & Malloy, Ltd.

(51) **LOC (14) Cl.** **24-02**

(57) **CLAIM**

(52) **U.S. Cl.**
USPC **D24/186**

The ornamental design for an analyte sensor inserter, as shown and described.

(58) **Field of Classification Search**
USPC D24/186, 187, 108, 165–168, 200, 231, D24/127

DESCRIPTION

CPC A61B 5/14503; A61B 5/14532; A61B 5/14546; A61B 5/14865
See application file for complete search history.

FIG. 1 is a top perspective view of an analyte sensor inserter showing our new design;
FIG. 2 is a front elevation view thereof;
FIG. 3 is a rear elevation view thereof;
FIG. 4 is a right side elevation view thereof;
FIG. 5 is a left side elevation view thereof;
FIG. 6 is a top plan view thereof;
FIG. 7 is a bottom plan view thereof; and,
FIG. 8 is a bottom perspective view thereof.
The dashed broken lines in the figures illustrate portions of the analyte sensor inserter that form no part of the claimed design.

(56) **References Cited**

U.S. PATENT DOCUMENTS

3,522,807 A 8/1970 Millenbach
3,670,727 A 6/1972 Reiterman
3,719,564 A 3/1973 Lilly, Jr. et al.
3,949,388 A 4/1976 Fuller
3,972,320 A 8/1976 Kalman
3,979,274 A 9/1976 Newman
4,008,717 A 2/1977 Kowarski
4,120,292 A 10/1978 LeBlanc, Jr. et al.

1 Claim, 8 Drawing Sheets

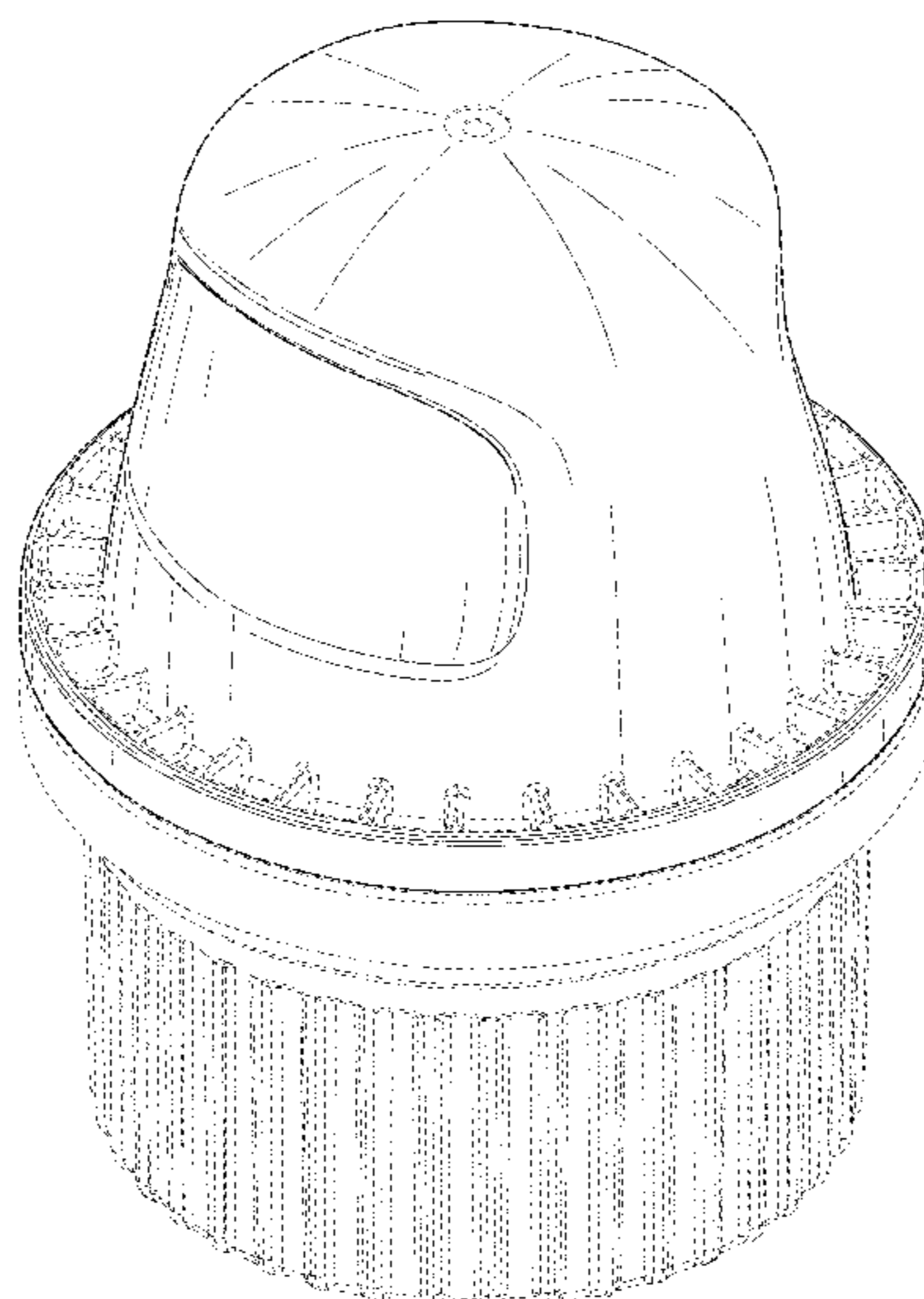

(56)

References Cited

U.S. PATENT DOCUMENTS

4,349,728 A	9/1982	Phillips et al.	5,733,044 A	3/1998	Rose et al.
4,356,074 A	10/1982	Johnson	5,741,211 A	4/1998	Renirie et al.
4,365,637 A	12/1982	Johnson	5,766,131 A	6/1998	Kondo et al.
4,373,527 A	2/1983	Fischell	5,771,001 A	6/1998	Cobb
4,404,066 A	9/1983	Johnson	5,772,586 A	6/1998	Heinonen et al.
4,431,004 A	2/1984	Bessman et al.	5,779,665 A	7/1998	Mastrototaro et al.
4,494,950 A	1/1985	Fischell	5,791,344 A	8/1998	Schulman et al.
4,509,531 A	4/1985	Ward	5,800,420 A	9/1998	Gross et al.
4,573,994 A	3/1986	Fischell et al.	5,807,375 A	9/1998	Gross et al.
4,595,011 A	6/1986	Phillips	5,814,020 A	9/1998	Gross
4,627,445 A	12/1986	Garcia et al.	5,820,551 A	10/1998	Hill et al.
4,627,842 A	12/1986	Katz	5,820,622 A	10/1998	Gross et al.
4,671,288 A	6/1987	Gough	5,822,715 A	10/1998	Worthington et al.
4,682,602 A	7/1987	Prohaska	5,827,184 A	10/1998	Netherly et al.
4,685,463 A	8/1987	Williams	5,840,020 A	11/1998	Heinonen et al.
4,685,466 A	8/1987	Rau	5,842,983 A	12/1998	Abel et al.
4,703,756 A	11/1987	Gough et al.	5,851,197 A	12/1998	Marano et al.
4,726,378 A	2/1988	Kaplan	5,858,001 A	1/1999	Tsals et al.
4,755,173 A	7/1988	Konopka	5,865,804 A	2/1999	Bachynsky
4,796,634 A	1/1989	Huntsman et al.	5,885,211 A	3/1999	Eppstein et al.
4,815,469 A	3/1989	Cohen et al.	5,899,855 A	5/1999	Brown
RE32,947 E	6/1989	Dormer et al.	5,924,979 A	7/1999	Sedlow et al.
4,871,440 A	10/1989	Nagata et al.	5,925,021 A	7/1999	Castellano et al.
4,897,173 A	1/1990	Nankai et al.	5,931,814 A	8/1999	Alex et al.
4,909,908 A	3/1990	Ross et al.	5,931,868 A	8/1999	Gross et al.
4,921,199 A	5/1990	Villaveces	5,948,006 A	9/1999	Mann
4,934,369 A	6/1990	Maxwell	5,951,521 A	9/1999	Mastrototaro et al.
4,953,552 A	9/1990	DeMarzo	5,954,643 A	9/1999	Van Antwerp
4,969,468 A	11/1990	Byers et al.	5,954,685 A	9/1999	Tierney
4,988,341 A	1/1991	Columbus et al.	5,957,854 A	9/1999	Besson et al.
4,994,167 A	2/1991	Shults et al.	5,961,451 A	10/1999	Reber et al.
4,995,402 A	2/1991	Smith et al.	5,964,993 A	10/1999	Blubaugh, Jr. et al.
5,047,044 A	9/1991	Smith et al.	5,965,380 A	10/1999	Heller et al.
5,050,612 A	9/1991	Matsumura	5,971,922 A	10/1999	Arita et al.
5,058,592 A	10/1991	Whisler	5,972,199 A	10/1999	Heller et al.
5,108,889 A	4/1992	Smith et al.	5,987,353 A	11/1999	Khatchatrian et al.
5,126,034 A	6/1992	Carter et al.	5,993,411 A	11/1999	Choi
5,140,985 A	8/1992	Schroeder et al.	5,995,860 A	11/1999	Sun et al.
5,217,595 A	6/1993	Smith et al.	5,997,501 A	12/1999	Gross et al.
5,264,103 A	11/1993	Yoshioka et al.	6,001,067 A	12/1999	Shults et al.
5,279,294 A	1/1994	Anderson	6,004,278 A	12/1999	Botich et al.
5,285,792 A	2/1994	Sjoquist et al.	6,017,335 A	1/2000	Burnham
5,299,571 A	4/1994	Mastrototaro	6,022,368 A	2/2000	Gavronsky et al.
5,372,133 A	12/1994	Hogen Esch	6,024,699 A	2/2000	Surwit et al.
5,372,427 A	12/1994	Padovani et al.	6,026,321 A	2/2000	Miyata et al.
5,390,671 A	2/1995	Lord et al.	6,027,459 A	2/2000	Shain et al.
5,391,250 A	2/1995	Cheney, II et al.	6,049,727 A	4/2000	Crothall
5,395,504 A	3/1995	Saurer et al.	6,056,718 A	5/2000	Funderburk et al.
5,408,999 A	4/1995	Singh et al.	6,068,399 A	5/2000	Tseng
5,472,317 A	12/1995	Field et al.	6,083,710 A	7/2000	Heller et al.
5,491,474 A	2/1996	Suni et al.	6,088,608 A	7/2000	Schulman et al.
5,494,562 A	2/1996	Maley et al.	6,091,975 A	7/2000	Daddona et al.
5,496,453 A	3/1996	Uenoyama et al.	6,091,976 A	7/2000	Pfeiffer et al.
5,497,772 A	3/1996	Schulman et al.	6,093,172 A	7/2000	Funderburk et al.
5,506,458 A	4/1996	Pace	6,102,896 A	8/2000	Roser
5,507,288 A	4/1996	Bocker et al.	6,103,033 A	8/2000	Say et al.
5,545,191 A	8/1996	Mann et al.	6,117,290 A	9/2000	Say et al.
5,560,357 A	10/1996	Faupei et al.	6,119,028 A	9/2000	Schulman et al.
5,568,806 A	10/1996	Cheney, II et al.	6,120,676 A	9/2000	Heller et al.
5,569,186 A	10/1996	Lord et al.	6,121,009 A	9/2000	Heller et al.
5,582,697 A	12/1996	Ikeda et al.	6,121,611 A	9/2000	Lindsay et al.
5,582,698 A	12/1996	Flaherty et al.	6,122,351 A	9/2000	Schlueter, Jr. et al.
5,584,813 A	12/1996	Livingston et al.	6,134,461 A	10/2000	Say et al.
5,586,553 A	12/1996	Haili et al.	6,143,164 A	11/2000	Heller et al.
5,601,435 A	2/1997	Quy	6,159,147 A	12/2000	Lichter et al.
5,617,851 A	4/1997	Lipkovker	6,162,611 A	12/2000	Heller et al.
5,640,954 A	6/1997	Pfeiffer et al.	6,175,752 B1	1/2001	Say et al.
5,651,869 A	7/1997	Yoshioka et al.	6,186,982 B1	2/2001	Gross et al.
5,653,239 A	8/1997	Pompei et al.	6,200,265 B1	3/2001	Walsh et al.
5,660,163 A	8/1997	Schulman et al.	6,212,416 B1	4/2001	Ward et al.
5,680,858 A	10/1997	Hansen et al.	6,219,574 B1	4/2001	Cormier et al.
5,682,233 A	10/1997	Brinda	6,248,067 B1	6/2001	Causey, III et al.
5,695,623 A	12/1997	Michel et al.	6,254,536 B1	7/2001	DeVito
5,711,861 A	1/1998	Ward et al.	6,254,586 B1	7/2001	Mann et al.
5,711,862 A	1/1998	Sakoda et al.	6,275,717 B1	8/2001	Gross et al.
			6,283,761 B1	9/2001	Joao
			6,283,982 B1	9/2001	Levaughn et al.
			6,284,478 B1	9/2001	Heller et al.
			6,293,925 B1	9/2001	Safabash et al.

(56)

References Cited

U.S. PATENT DOCUMENTS

6,295,506 B1	9/2001	Heinonen et al.	6,810,290 B2	10/2004	Lebel et al.
6,306,104 B1	10/2001	Cunningham et al.	6,811,533 B2	11/2004	Lebel et al.
6,309,884 B1	10/2001	Cooper et al.	6,811,534 B2	11/2004	Bowman, IV et al.
6,329,161 B1	12/2001	Heller et al.	6,813,519 B2	11/2004	Lebel et al.
6,331,244 B1	12/2001	Lewis et al.	6,830,551 B1	12/2004	Uchigaki et al.
6,338,790 B1	1/2002	Feldman et al.	6,837,858 B2	1/2005	Cunningham et al.
6,348,640 B1	2/2002	Navot et al.	6,837,988 B2	1/2005	Leong et al.
6,359,444 B1	3/2002	Grimes	6,849,052 B2	2/2005	Ughigaki et al.
6,360,888 B1	3/2002	McIvor et al.	6,854,882 B2	2/2005	Chen
6,366,794 B1	4/2002	Moussy et al.	6,862,465 B2	3/2005	Shults et al.
6,368,141 B1	4/2002	Van Antwerp et al.	6,873,268 B2	3/2005	Lebel et al.
6,368,274 B1	4/2002	Van Antwerp et al.	6,881,551 B2	4/2005	Heller et al.
6,377,828 B1	4/2002	Chaiken et al.	6,892,085 B2	5/2005	McIvor et al.
6,379,301 B1	4/2002	Worthington et al.	6,895,265 B2	5/2005	Silver
6,409,740 B1	6/2002	Kuhr et al.	6,931,327 B2	8/2005	Goode, Jr. et al.
6,413,393 B1	7/2002	Van Antwerp et al.	6,932,894 B2	8/2005	Mao et al.
6,418,332 B1	7/2002	Mastrototaro et al.	6,936,006 B2	8/2005	Sabra
6,424,847 B1	7/2002	Mastrototaro et al.	6,942,518 B2	9/2005	Liamos et al.
6,427,088 B1	7/2002	Bowman, IV	6,950,708 B2	9/2005	Bowman, IV et al.
6,437,679 B1	8/2002	Rogues	6,953,589 B1	10/2005	Trautman et al.
6,440,068 B1	8/2002	Brown et al.	6,958,705 B2	10/2005	Lebel et al.
6,445,374 B2	9/2002	Albert et al.	6,959,211 B2	10/2005	Rule et al.
6,478,736 B1	11/2002	Mault	6,968,294 B2	11/2005	Gutta et al.
6,482,176 B1	11/2002	Wich	6,971,274 B2	12/2005	Olin
6,484,045 B1	11/2002	Holker et al.	6,971,999 B2	12/2005	Py et al.
6,484,046 B1	11/2002	Say et al.	6,974,437 B2	12/2005	Lebel et al.
6,514,718 B2	2/2003	Heller et al.	6,990,366 B2	1/2006	Say et al.
6,520,326 B2	2/2003	McIvor et al.	6,997,907 B2	2/2006	Safabash et al.
6,522,927 B1	2/2003	Bishay et al.	6,998,247 B2	2/2006	Monfre et al.
6,551,494 B1	4/2003	Heller et al.	7,003,336 B2	2/2006	Holker et al.
6,554,798 B1	4/2003	Mann et al.	7,003,340 B2	2/2006	Say et al.
6,558,320 B1	5/2003	Causey, III et al.	7,003,341 B2	2/2006	Say et al.
6,558,321 B1	5/2003	Burd et al.	7,024,245 B2	4/2006	Lebel et al.
6,560,471 B1	5/2003	Heller et al.	7,025,743 B2	4/2006	Mann et al.
6,561,978 B1	5/2003	Conn et al.	7,041,068 B2	5/2006	Freeman et al.
6,562,001 B2	5/2003	Lebel et al.	7,041,468 B2	5/2006	Drucker et al.
6,564,105 B2	5/2003	Starkweather et al.	7,052,483 B2	5/2006	Wojcik
6,565,509 B1	5/2003	Say et al.	7,056,302 B2	6/2006	Douglas
6,571,128 B2	5/2003	Lebel et al.	7,074,307 B2	7/2006	Simpson et al.
6,572,566 B2	6/2003	Effenhauser	7,081,195 B2	7/2006	Simpson et al.
6,576,101 B1	6/2003	Heller et al.	7,097,637 B2	8/2006	Triplett et al.
6,577,899 B2	6/2003	Lebel et al.	7,098,803 B2	8/2006	Mann et al.
6,579,690 B1	6/2003	Bonnecaze et al.	7,108,778 B2	9/2006	Simpson et al.
6,585,644 B2	7/2003	Lebel et al.	7,110,803 B2	9/2006	Shults et al.
6,589,229 B1	7/2003	Connelly et al.	7,113,821 B1	9/2006	Sun et al.
6,591,125 B1	7/2003	Buse et al.	7,134,999 B2	11/2006	Brauker et al.
6,595,919 B2	7/2003	Berner et al.	7,136,689 B2	11/2006	Shults et al.
6,605,200 B1	8/2003	Mao et al.	7,163,511 B2	1/2007	Conn et al.
6,605,201 B1	8/2003	Mao et al.	7,171,274 B2	1/2007	Starkweather et al.
6,607,509 B2	8/2003	Bobroff et al.	7,190,988 B2	3/2007	Say et al.
6,610,012 B2	8/2003	Mault	7,192,450 B2	3/2007	Brauker et al.
6,633,772 B2	10/2003	Ford et al.	7,198,606 B2	4/2007	Boecker et al.
6,635,014 B2	10/2003	Starkweather et al.	7,207,974 B2	4/2007	Safabash et al.
6,648,821 B2	11/2003	Lebel et al.	7,226,978 B2	6/2007	Tapsak et al.
6,654,625 B1	11/2003	Say et al.	7,276,029 B2	10/2007	Goode, Jr. et al.
6,659,948 B2	12/2003	Lebel et al.	7,278,983 B2	10/2007	Ireland et al.
6,666,849 B1	12/2003	Marshall et al.	7,297,151 B2	11/2007	Boecker et al.
6,668,196 B1	12/2003	Villegas et al.	7,299,082 B2	11/2007	Feldman et al.
6,676,290 B1	1/2004	Lu	7,310,544 B2	12/2007	Brister et al.
6,682,338 B2	1/2004	Maurilio	7,318,816 B2	1/2008	Bobroff et al.
6,687,546 B2	2/2004	Lebel et al.	7,324,012 B2	1/2008	Mann et al.
6,689,056 B1	2/2004	Kilcoyne et al.	7,329,239 B2	2/2008	Safabash et al.
6,694,191 B2	2/2004	Starkweather et al.	7,335,294 B2	2/2008	Heller et al.
6,695,860 B1	2/2004	Ward et al.	7,340,287 B2	3/2008	Mason et al.
6,699,188 B2	3/2004	Wessel	7,340,309 B2	3/2008	Miazga et al.
6,702,857 B2	3/2004	Brauker et al.	7,354,420 B2	4/2008	Steil et al.
6,733,446 B2	5/2004	Lebel et al.	7,364,592 B2	4/2008	Carr-Brendel et al.
6,740,075 B2	5/2004	Lebel et al.	7,366,556 B2	4/2008	Brister et al.
6,741,877 B1	5/2004	Shults et al.	7,379,765 B2	5/2008	Petisce et al.
6,746,582 B2	6/2004	Heller et al.	7,381,184 B2	6/2008	Funderburk et al.
6,758,810 B2	7/2004	Lebel et al.	7,402,153 B2	7/2008	Steil et al.
6,770,030 B1	8/2004	Schaupp et al.	7,407,493 B2	8/2008	Cane
6,771,995 B2	8/2004	Kurnik	7,416,541 B2	8/2008	Yuzhakov et al.
6,790,178 B1	9/2004	Mault et al.	7,424,318 B2	9/2008	Brister et al.
6,809,653 B1	10/2004	Mann et al.	7,455,663 B2	11/2008	Bikovsky
			7,460,898 B2	12/2008	Brister et al.
			7,467,003 B2	12/2008	Brister et al.
			7,471,972 B2	12/2008	Rhodes et al.
			7,494,465 B2	2/2009	Brister et al.

US D982,762 S

(56)

References Cited

U.S. PATENT DOCUMENTS

7,497,827 B2	3/2009	Brister et al.		2001/0056262 A1	12/2001	Cabiri et al.	
7,519,408 B2	4/2009	Rasdal et al.		2002/0013538 A1	1/2002	Teller	
7,583,990 B2	9/2009	Goode, Jr. et al.		2002/0019022 A1	2/2002	Dunn et al.	
7,591,801 B2	9/2009	Brauker et al.		2002/0019606 A1	2/2002	Lebel et al.	
7,599,726 B2	10/2009	Goode, Jr. et al.		2002/0022855 A1	2/2002	Bobroff et al.	
7,604,592 B2	10/2009	Freeman et al.		2002/0023852 A1	2/2002	McIvor et al.	
7,613,491 B2	11/2009	Boock et al.		2002/0042090 A1	4/2002	Heller et al.	
7,615,007 B2	11/2009	Shults et al.		2002/0055711 A1	5/2002	Lavi et al.	
7,632,228 B2	12/2009	Brauker et al.		2002/0057993 A1	5/2002	Maisey et al.	
7,637,868 B2	12/2009	Saint et al.		2002/0066764 A1	6/2002	Perry et al.	
7,640,048 B2	12/2009	Dobbles et al.		2002/0076966 A1	6/2002	Carron et al.	
7,651,596 B2	1/2010	Petisce et al.		2002/0082487 A1	6/2002	Kollias et al.	
7,654,956 B2	2/2010	Brister et al.		2002/0103499 A1	8/2002	Perez et al.	
7,657,297 B2	2/2010	Simpson et al.		2002/0106709 A1	8/2002	Potts et al.	
7,666,149 B2	2/2010	Simons et al.		2002/0119711 A1	8/2002	Van Antwerp et al.	
7,697,967 B2	4/2010	Stafford		2002/0128594 A1	9/2002	Das et al.	
7,699,807 B2	4/2010	Faust et al.		2002/0130042 A1	9/2002	Moerman et al.	
7,711,402 B2	5/2010	Shults et al.		2002/0154050 A1	10/2002	Krupp et al.	
7,713,574 B2	5/2010	Brister et al.		2002/0161288 A1	10/2002	Shin et al.	
7,715,893 B2	5/2010	Kamath et al.		2002/0165462 A1	11/2002	Westbrook et al.	
D618,337 S	6/2010	Pratt		2002/0169369 A1	11/2002	Ward et al.	
7,727,147 B1	6/2010	Osorio et al.		2002/0198444 A1	12/2002	Ughigaki et al.	
7,731,657 B2	6/2010	Stafford		2003/0023317 A1	1/2003	Brauker et al.	
7,736,344 B2	6/2010	Moberg et al.		2003/0023461 A1	1/2003	Quintanilla et al.	
7,763,042 B2	7/2010	Iio et al.		2003/0032867 A1	2/2003	Crothall et al.	
7,822,454 B1	10/2010	Alden et al.		2003/0032874 A1	2/2003	Rhodes et al.	
7,850,652 B2	12/2010	Liniger et al.		2003/0042137 A1	3/2003	Mao et al.	
7,896,844 B2	3/2011	Thalmann et al.		2003/0060753 A1	3/2003	Starkweather et al.	
7,955,297 B2	6/2011	Radmer et al.		2003/0065308 A1	4/2003	Lebel et al.	
7,985,203 B2	7/2011	Haueter et al.		2003/0069510 A1	4/2003	Semler	
D642,690 S *	8/2011	Altmann	D24/186	2003/0078481 A1	4/2003	McIvor et al.	
8,114,023 B2	2/2012	Ward		2003/0078560 A1	4/2003	Miller et al.	
8,172,805 B2	5/2012	Mogensen et al.		2003/0097092 A1	5/2003	Flaherty	
8,262,618 B2	9/2012	Scheurer		2003/0100040 A1	5/2003	Bonnecaze et al.	
D668,164 S	10/2012	Cowles		2003/0109775 A1	6/2003	O'Neil et al.	
8,409,145 B2	4/2013	Raymond et al.		2003/0073686 A1	7/2003	Nugiel et al.	
8,486,003 B2	7/2013	Nielsen		2003/0134347 A1	7/2003	Heller et al.	
D691,710 S	10/2013	White		2003/0135333 A1	7/2003	Aceti et al.	
D694,397 S	11/2013	White		2003/0144581 A1	7/2003	Conn et al.	
8,696,570 B2	4/2014	Yodfat et al.		2003/0144608 A1	7/2003	Kojima et al.	
8,734,391 B2	5/2014	Yodfat et al.		2003/0155656 A1	8/2003	Chiu et al.	
8,747,363 B2	6/2014	Nielsen et al.		2003/0168338 A1	9/2003	Gao et al.	
8,795,309 B2 *	8/2014	Lacy	A61M 5/158 604/93.01	2003/0176933 A1	9/2003	Lebel et al.	
8,844,007 B2	9/2014	Vicente		2003/0187338 A1	10/2003	Say et al.	
8,864,664 B2	10/2014	Frey et al.		2003/0199790 A1	10/2003	Boecker et al.	
8,870,822 B2	10/2014	Thalmann et al.		2003/0199910 A1	10/2003	Boecker et al.	
8,880,138 B2	11/2014	Cho		2003/0212379 A1	11/2003	Bylund et al.	
D719,267 S *	12/2014	Vaccarella	D24/187	2003/0217966 A1	11/2003	Tapsak et al.	
8,930,028 B2	1/2015	McKee		2003/0225361 A1	12/2003	Sabra	
8,971,981 B2	3/2015	Yodfat et al.		2004/0002682 A1	1/2004	Kovelman et al.	
D731,334 S	6/2015	Fiedler		2004/0010207 A1	1/2004	Flaherty et al.	
9,072,476 B2	7/2015	Shah et al.		2004/0011671 A1	1/2004	Shults et al.	
9,295,786 B2	3/2016	Gottlieb et al.		2004/0040840 A1	3/2004	Mao et al.	
D760,384 S *	6/2016	Niunoya	D24/127	2004/0045879 A1	3/2004	Shults et al.	
9,402,544 B2	8/2016	Yee		2004/0054263 A1	3/2004	Moerman et al.	
9,439,599 B2	9/2016	Thompson et al.		2004/0064068 A1	4/2004	DeNuzzio et al.	
D775,987 S	1/2017	Sheridan		2004/0064133 A1	4/2004	Miller et al.	
D776,285 S	1/2017	Dinger		2004/0096959 A1	5/2004	Steine et al.	
9,590,438 B2 *	3/2017	Dalton	A61B 5/0024	2004/0106858 A1	6/2004	Say et al.	
9,610,127 B2	4/2017	Heck et al.		2004/0106859 A1	6/2004	Say et al.	
D806,254 S	12/2017	Im		2004/0116847 A1	6/2004	Wall	
D810,952 S	2/2018	Hsu		2004/0116865 A1	6/2004	Bengtsson	
D824,034 S	7/2018	Pushpala		2004/0116866 A1	6/2004	Gorman et al.	
D830,856 S	10/2018	Golnik		2004/0122353 A1	6/2004	Shahmirian et al.	
D847,365 S	4/2019	Vellutato, Jr.		2004/0122489 A1	6/2004	Mazar et al.	
10,448,872 B2	10/2019	Wolfe et al.		2004/0133164 A1	7/2004	Funderburk et al.	
D882,432 S	4/2020	Yee et al.		2004/0135684 A1	7/2004	Steinhal et al.	
D888,252 S *	6/2020	Terry	D24/186	2004/0138544 A1	7/2004	Ward et al.	
10,827,954 B2	11/2020	Hoss et al.		2004/0138588 A1	7/2004	Saikley et al.	
D903,877 S *	12/2020	Pace	A61B 5/6849 D24/186	2004/0138688 A1	7/2004	Giraud	
10,959,654 B2	3/2021	Curry et al.		2004/0147996 A1	7/2004	Miazga et al.	
10,973,449 B2	4/2021	Stafford		2004/0152622 A1	8/2004	Keith et al.	
D923,800 S *	6/2021	Martin	D24/187	2004/0158207 A1	8/2004	Hunn et al.	
				2004/0167801 A1	8/2004	Say et al.	
				2004/0171910 A1	9/2004	Moore-Steele	

D924,406 S * 7/2021 Yee D24/186
 D926,326 S * 7/2021 Terry D24/169
 D948,722 S * 4/2022 Donnay A61B 5/1513
 D24/169

(56)

References Cited

U.S. PATENT DOCUMENTS

2004/0171921	A1	9/2004	Say et al.	2006/0036139	A1	2/2006	Brister et al.
2004/0176672	A1	9/2004	Silver et al.	2006/0036140	A1	2/2006	Brister et al.
2004/0186362	A1	9/2004	Brauker et al.	2006/0036141	A1	2/2006	Kamath et al.
2004/0186365	A1	9/2004	Jin et al.	2006/0036142	A1	2/2006	Brister et al.
2004/0193090	A1	9/2004	Lebel et al.	2006/0036143	A1	2/2006	Brister et al.
2004/0199059	A1	10/2004	Brauker et al.	2006/0036144	A1	2/2006	Brister et al.
2004/0204687	A1	10/2004	Mogensen et al.	2006/0036145	A1	2/2006	Chambers et al.
2004/0210122	A1	10/2004	Sleburg	2006/0047220	A1	3/2006	Sakata et al.
2004/0223985	A1	11/2004	Dunfield et al.	2006/0081469	A1	4/2006	Lee
2004/0225338	A1	11/2004	Lebel et al.	2006/0129173	A1	6/2006	Wilkinson
2004/0236200	A1	11/2004	Say et al.	2006/0155210	A1	7/2006	Beckman et al.
2004/0236251	A1	11/2004	Roe et al.	2006/0155317	A1	7/2006	List
2004/0254433	A1	12/2004	Bandis et al.	2006/0166629	A1	7/2006	Reggiardo
2004/0254434	A1	12/2004	Goodnow et al.	2006/0173444	A1	8/2006	Choy et al.
2004/0267300	A1	12/2004	Mace	2006/0189863	A1	8/2006	Peysen et al.
2005/0003470	A1	1/2005	Nelson et al.	2006/0189939	A1	8/2006	Gonnelli et al.
2005/0004494	A1	1/2005	Perez et al.	2006/0195029	A1	8/2006	Shults et al.
2005/0006122	A1	1/2005	Burnette	2006/0200181	A1	9/2006	Fukuzawa et al.
2005/0010269	A1	1/2005	Lebel et al.	2006/0200970	A1	9/2006	Brister et al.
2005/0027177	A1	2/2005	Shin et al.	2006/0222566	A1	10/2006	Brauker et al.
2005/0027180	A1	2/2005	Goode, Jr. et al.	2006/0224171	A1	10/2006	Sakata et al.
2005/0031689	A1	2/2005	Shults et al.	2006/0226985	A1	10/2006	Goodnow et al.
2005/0043598	A1	2/2005	Goode, Jr. et al.	2006/0247508	A1	11/2006	Fennell
2005/0070819	A1	3/2005	Poux et al.	2006/0253086	A1	11/2006	Moberg et al.
2005/0085872	A1	4/2005	Yanagihara et al.	2006/0258929	A1	11/2006	Goode, Jr. et al.
2005/0090607	A1	4/2005	Tapsak et al.	2006/0264888	A1	11/2006	Moberg et al.
2005/0090725	A1	4/2005	Page et al.	2006/0276724	A1	12/2006	Freeman et al.
2005/0090850	A1	4/2005	Thoes et al.	2006/0282042	A1	12/2006	Walters et al.
2005/0101912	A1	5/2005	Faust et al.	2006/0287591	A1	12/2006	Ocvirk et al.
2005/0106713	A1	5/2005	Phan et al.	2007/0016381	A1	1/2007	Kamath et al.
2005/0112169	A1	5/2005	Brauker et al.	2007/0027381	A1	2/2007	Stafford
2005/0114068	A1	5/2005	Chey et al.	2007/0038044	A1	2/2007	Dobbles et al.
2005/0121322	A1	6/2005	Say et al.	2007/0060814	A1	3/2007	Stafford
2005/0131346	A1	6/2005	Douglas	2007/0073129	A1	3/2007	Shah et al.
2005/0131347	A1	6/2005	Marano-Ford	2007/0078320	A1	4/2007	Stafford
2005/0143635	A1	6/2005	Kamath et al.	2007/0078321	A1	4/2007	Mazza et al.
2005/0154410	A1	7/2005	Conway et al.	2007/0078322	A1	4/2007	Stafford
2005/0165404	A1	7/2005	Miller	2007/0088377	A1	4/2007	Levaughn et al.
2005/0173245	A1	8/2005	Feldman et al.	2007/0106135	A1	5/2007	Sloan et al.
2005/0176136	A1	8/2005	Burd et al.	2007/0110124	A1	5/2007	Shiraki et al.
2005/0182306	A1	8/2005	Sloan	2007/0123819	A1	5/2007	Mernoe et al.
2005/0187720	A1	8/2005	Goode, Jr. et al.	2007/0149875	A1	6/2007	Ouyang et al.
2005/0192557	A1	9/2005	Brauker et al.	2007/0156094	A1	7/2007	Safabash et al.
2005/0195930	A1	9/2005	Spital et al.	2007/0163880	A1	7/2007	Woo et al.
2005/0197554	A1	9/2005	Polcha	2007/0173706	A1	7/2007	Neinast et al.
2005/0199494	A1	9/2005	Say et al.	2007/0173741	A1	7/2007	Deshmukh et al.
2005/0203360	A1	9/2005	Brauker et al.	2007/0191701	A1	8/2007	Feldman et al.
2005/0222518	A1	10/2005	Dib	2007/0203407	A1	8/2007	Hoss et al.
2005/0222599	A1	10/2005	Czemecki et al.	2007/0203966	A1	8/2007	Brauker et al.
2005/0236277	A9	10/2005	Imran et al.	2007/0213611	A1	9/2007	Simpson et al.
2005/0239154	A1	10/2005	Feldman et al.	2007/0235331	A1	10/2007	Simpson et al.
2005/0239156	A1	10/2005	Drucker et al.	2007/0244368	A1	10/2007	Bayloff et al.
2005/0241957	A1	11/2005	Mao et al.	2007/0244398	A1	10/2007	Lo et al.
2005/0245795	A1	11/2005	Goode, Jr. et al.	2007/0249922	A1	10/2007	Peysen et al.
2005/0245799	A1	11/2005	Brauker et al.	2007/0255302	A1	11/2007	Koeppel et al.
2005/0245844	A1	11/2005	Mace et al.	2008/0004512	A1	1/2008	Funderbunk et al.
2005/0267440	A1	12/2005	Herman et al.	2008/0004573	A1	1/2008	Kaufmann et al.
2005/0277164	A1	12/2005	Drucker et al.	2008/0009692	A1	1/2008	Stafford
2005/0283114	A1	12/2005	Bresina et al.	2008/0009805	A1	1/2008	Ethelfeld
2005/0287620	A1	12/2005	Heller et al.	2008/0017522	A1	1/2008	Heller et al.
2006/0001538	A1	1/2006	Kraft et al.	2008/0021666	A1	1/2008	Goode, Jr. et al.
2006/0004303	A1	1/2006	Weidenhaupt et al.	2008/0027474	A1	1/2008	Curry et al.
2006/0009727	A1	1/2006	O'Mahony et al.	2008/0029391	A1	2/2008	Mao et al.
2006/0010098	A1	1/2006	Goodnow et al.	2008/0031941	A1	2/2008	Pettersson
2006/0015020	A1	1/2006	Neale et al.	2008/0033254	A1	2/2008	Kamath et al.
2006/0015024	A1	1/2006	Brister et al.	2008/0033268	A1	2/2008	Stafford
2006/0016700	A1	1/2006	Brister et al.	2008/0033318	A1	2/2008	Mace et al.
2006/0019327	A1	1/2006	Brister et al.	2008/0039702	A1	2/2008	Hayter et al.
2006/0020186	A1	1/2006	Brister et al.	2008/0045824	A1	2/2008	Tapsak et al.
2006/0020187	A1	1/2006	Brister et al.	2008/0064937	A1	3/2008	McGarraugh et al.
2006/0020188	A1	1/2006	Kamath et al.	2008/0064941	A1	3/2008	Funderbunk et al.
2006/0020189	A1	1/2006	Brister et al.	2008/0064944	A1	3/2008	Van Antwerp et al.
2006/0020190	A1	1/2006	Kamath et al.	2008/0065646	A1	3/2008	Zhang et al.
2006/0020191	A1	1/2006	Brister et al.	2008/0071156	A1	3/2008	Brister et al.
2006/0020192	A1	1/2006	Brister et al.	2008/0083617	A1	4/2008	Simpson et al.
				2008/0086042	A1	4/2008	Brister et al.
				2008/0086044	A1	4/2008	Brister et al.
				2008/0086273	A1	4/2008	Shults et al.
				2008/0097246	A1	4/2008	Stafford

(56)

References Cited

U.S. PATENT DOCUMENTS

2008/0108942	A1	5/2008	Brister et al.	2009/0099436	A1	4/2009	Brister et al.
2008/0112848	A1	5/2008	Huffstodt et al.	2009/0102678	A1	4/2009	Mazza et al.
2008/0114280	A1	5/2008	Stafford	2009/0105569	A1	4/2009	Stafford
2008/0119707	A1	5/2008	Stafford	2009/0124877	A1	5/2009	Goode, Jr. et al.
2008/0133707	A1	6/2008	Sharma et al.	2009/0124878	A1	5/2009	Goode et al.
2008/0139903	A1	6/2008	Bruce et al.	2009/0124879	A1	5/2009	Brister et al.
2008/0154205	A1	6/2008	Wojcik	2009/0124964	A1	5/2009	Leach et al.
2008/0161664	A1	7/2008	Mastrototaro et al.	2009/0124979	A1	5/2009	Raymond et al.
2008/0167578	A1	7/2008	Bryer et al.	2009/0131768	A1	5/2009	Simpson et al.
2008/0183061	A1	7/2008	Goode, Jr. et al.	2009/0131769	A1	5/2009	Leach et al.
2008/0183399	A1	7/2008	Goode, Jr. et al.	2009/0131776	A1	5/2009	Simpson et al.
2008/0188731	A1	8/2008	Brister et al.	2009/0131777	A1	5/2009	Simpson et al.
2008/0189051	A1	8/2008	Goode, Jr. et al.	2009/0131860	A1	5/2009	Nielsen
2008/0194935	A1	8/2008	Brister et al.	2009/0137886	A1	5/2009	Shariati et al.
2008/0194936	A1	8/2008	Goode, Jr. et al.	2009/0137887	A1	5/2009	Shariati et al.
2008/0194937	A1	8/2008	Goode, Jr. et al.	2009/0143659	A1	6/2009	Li et al.
2008/0194938	A1	8/2008	Brister et al.	2009/0143660	A1	6/2009	Brister et al.
2008/0195049	A1	8/2008	Thalmann et al.	2009/0156919	A1	6/2009	Brister et al.
2008/0195232	A1	8/2008	Carr-Brendel et al.	2009/0156924	A1	6/2009	Shariati et al.
2008/0195967	A1	8/2008	Goode, Jr. et al.	2009/0163790	A1	6/2009	Brister et al.
2008/0197024	A1	8/2008	Simpson et al.	2009/0163791	A1	6/2009	Brister et al.
2008/0200788	A1	8/2008	Brister et al.	2009/0171182	A1	7/2009	Stafford
2008/0200789	A1	8/2008	Brister et al.	2009/0178459	A1	7/2009	Li et al.
2008/0200791	A1	8/2008	Simpson et al.	2009/0182217	A1	7/2009	Li et al.
2008/0200897	A1	8/2008	Hoss et al.	2009/0192366	A1	7/2009	Mensinger et al.
2008/0208025	A1	8/2008	Shults et al.	2009/0192380	A1	7/2009	Shariati et al.
2008/0214481	A1	9/2008	Challoner et al.	2009/0192722	A1	7/2009	Shariati et al.
2008/0214915	A1	9/2008	Brister et al.	2009/0192724	A1	7/2009	Brauker et al.
2008/0214918	A1	9/2008	Brister et al.	2009/0192745	A1	7/2009	Kamath et al.
2008/0228051	A1	9/2008	Shults et al.	2009/0192751	A1	7/2009	Kamath et al.
2008/0228054	A1	9/2008	Shults et al.	2009/0198215	A1	8/2009	Chong et al.
2008/0242961	A1	10/2008	Brister et al.	2009/0203981	A1	8/2009	Brauker et al.
2008/0249383	A1	10/2008	Sass et al.	2009/0204341	A1	8/2009	Brauker et al.
2008/0255440	A1	10/2008	Eilerson et al.	2009/0212766	A1	8/2009	Olson et al.
2008/0262469	A1	10/2008	Brister et al.	2009/0216103	A1	8/2009	Brister et al.
2008/0269673	A1	10/2008	Butoi et al.	2009/0240120	A1	9/2009	Mensinger et al.
2008/0275313	A1	11/2008	Brister et al.	2009/0240128	A1	9/2009	Mensinger et al.
2008/0283396	A1	11/2008	Wang et al.	2009/0240193	A1	9/2009	Mensinger et al.
2008/0287764	A1	11/2008	Rasdal et al.	2009/0242399	A1	10/2009	Kamath et al.
2008/0287765	A1	11/2008	Rasdal et al.	2009/0242425	A1	10/2009	Kamath et al.
2008/0287766	A1	11/2008	Rasdal et al.	2009/0247855	A1	10/2009	Boock et al.
2008/0294096	A1	11/2008	Uber et al.	2009/0247856	A1	10/2009	Boock et al.
2008/0296155	A1	12/2008	Shults et al.	2009/0259118	A1	10/2009	Feldman et al.
2008/0300476	A1	12/2008	Stafford	2009/0259201	A1	10/2009	Hwang et al.
2008/0306368	A1	12/2008	Goode, Jr. et al.	2009/0259202	A1	10/2009	Leeflang et al.
2008/0306434	A1	12/2008	Dobbles et al.	2009/0270765	A1	10/2009	Ghesquire et al.
2008/0306435	A1	12/2008	Kamath et al.	2009/0287073	A1	11/2009	Boock et al.
2008/0306444	A1	12/2008	Brister et al.	2009/0287074	A1	11/2009	Shults et al.
2008/0319414	A1	12/2008	Yodfat et al.	2009/0292184	A1	11/2009	Funderburk et al.
2009/0005659	A1	1/2009	Kollias et al.	2009/0292185	A1	11/2009	Funderburk et al.
2009/0012377	A1	1/2009	Jennewine et al.	2009/0299155	A1	12/2009	Yang et al.
2009/0012379	A1	1/2009	Goode, Jr. et al.	2009/0299156	A1	12/2009	Simpson et al.
2009/0018424	A1	1/2009	Kamath et al.	2009/0299162	A1	12/2009	Brauker et al.
2009/0030294	A1	1/2009	Petisce et al.	2009/0299167	A1	12/2009	Seymour
2009/0036758	A1	2/2009	Brauker et al.	2009/0299276	A1	12/2009	Brauker et al.
2009/0036763	A1	2/2009	Brauker et al.	2010/0004597	A1	1/2010	Gryn et al.
2009/0036915	A1	2/2009	Karbowniczek et al.	2010/0010324	A1	1/2010	Brauker et al.
2009/0043181	A1	2/2009	Brauker et al.	2010/0010331	A1	1/2010	Brauker et al.
2009/0043182	A1	2/2009	Brauker et al.	2010/0010332	A1	1/2010	Brauker et al.
2009/0043525	A1	2/2009	Brauker et al.	2010/0016687	A1	1/2010	Brauker et al.
2009/0043541	A1	2/2009	Brauker et al.	2010/0016698	A1	1/2010	Rasdal et al.
2009/0043542	A1	2/2009	Brauker et al.	2010/0022855	A1	1/2010	Brauker et al.
2009/0045055	A1	2/2009	Rhodes et al.	2010/0022863	A1	1/2010	Mogensen et al.
2009/0054866	A1	2/2009	Teisen-Simony et al.	2010/0030038	A1	2/2010	Brauker et al.
2009/0062633	A1	3/2009	Brauker et al.	2010/0030053	A1	2/2010	Goode, Jr. et al.
2009/0062635	A1	3/2009	Brauker et al.	2010/0030111	A1	2/2010	Perriere
2009/0069658	A1	3/2009	Say et al.	2010/0030484	A1	2/2010	Brauker et al.
2009/0069750	A1	3/2009	Schraga	2010/0030485	A1	2/2010	Brauker et al.
2009/0076356	A1	3/2009	Simpson et al.	2010/0036215	A1	2/2010	Goode, Jr. et al.
2009/0076359	A1	3/2009	Peyser	2010/0036216	A1	2/2010	Goode, Jr. et al.
2009/0076360	A1	3/2009	Brister et al.	2010/0036222	A1	2/2010	Goode, Jr. et al.
2009/0076361	A1	3/2009	Kamath et al.	2010/0036223	A1	2/2010	Goode, Jr. et al.
2009/0082693	A1	3/2009	Stafford	2010/0036225	A1	2/2010	Goode, Jr. et al.
2009/0088614	A1	4/2009	Taub	2010/0036281	A1	2/2010	Doi
2009/0088787	A1	4/2009	Koike et al.	2010/0036281	A1	2/2010	Doi
				2010/0041971	A1	2/2010	Goode, Jr. et al.
				2010/0045465	A1	2/2010	Brauker et al.
				2010/0049014	A1	2/2010	Funderburk et al.
				2010/0049024	A1	2/2010	Saint et al.
				2010/0063373	A1	3/2010	Kamath et al.

(56)

References Cited

U.S. PATENT DOCUMENTS

2010/0069728	A1	3/2010	Funderburk et al.	2011/0028816	A1	2/2011	Simpson et al.
2010/0076283	A1	3/2010	Simpson et al.	2011/0040256	A1	2/2011	Bobroff et al.
2010/0081908	A1	4/2010	Dobbles et al.	2011/0040263	A1	2/2011	Hordum et al.
2010/0081910	A1	4/2010	Brister et al.	2011/0046456	A1	2/2011	Hordum et al.
2010/0087724	A1	4/2010	Brauker et al.	2011/0046467	A1	2/2011	Simpson et al.
2010/0096259	A1	4/2010	Zhang et al.	2011/0054275	A1	3/2011	Stafford
2010/0099970	A1	4/2010	Shults et al.	2011/0060196	A1	3/2011	Stafford
2010/0099971	A1	4/2010	Shults et al.	2011/0073475	A1	3/2011	Kastanos et al.
2010/0100113	A1	4/2010	Iio et al.	2011/0077490	A1	3/2011	Simpson et al.
2010/0113897	A1	5/2010	Brenneman et al.	2011/0082484	A1	4/2011	Saravia et al.
2010/0119693	A1	5/2010	Tapsak et al.	2011/0106126	A1	5/2011	Love et al.
2010/0121169	A1	5/2010	Petisce et al.	2011/0118579	A1	5/2011	Goode et al.
2010/0145377	A1	6/2010	Lai et al.	2011/0118580	A1	5/2011	Goode et al.
2010/0168677	A1	7/2010	Gabriel et al.	2011/0124992	A1	5/2011	Brauker et al.
2010/0174157	A1	7/2010	Brister et al.	2011/0124997	A1	5/2011	Goode et al.
2010/0174158	A1	7/2010	Kamath et al.	2011/0125410	A1	5/2011	Goode et al.
2010/0174163	A1	7/2010	Brister et al.	2011/0130970	A1	6/2011	Goode et al.
2010/0174164	A1	7/2010	Brister et al.	2011/0130971	A1	6/2011	Goode et al.
2010/0174165	A1	7/2010	Brister et al.	2011/0130998	A1	6/2011	Goode et al.
2010/0174166	A1	7/2010	Brister et al.	2011/0137257	A1	6/2011	Gyrn et al.
2010/0174167	A1	7/2010	Kamath et al.	2011/0144465	A1	6/2011	Shults et al.
2010/0174168	A1	7/2010	Goode et al.	2011/0178378	A1	7/2011	Brister et al.
2010/0179401	A1	7/2010	Rasdal et al.	2011/0178461	A1	7/2011	Chong et al.
2010/0179402	A1	7/2010	Goode, Jr. et al.	2011/0184258	A1	7/2011	Stafford
2010/0179404	A1	7/2010	Kamath et al.	2011/0184265	A1	7/2011	Hayter
2010/0179408	A1	7/2010	Kamath et al.	2011/0190603	A1	8/2011	Stafford
2010/0179409	A1	7/2010	Kamath et al.	2011/0190614	A1	8/2011	Brister et al.
2010/0185065	A1	7/2010	Goode, Jr. et al.	2011/0191044	A1	8/2011	Stafford
2010/0185069	A1	7/2010	Brister et al.	2011/0201910	A1	8/2011	Rasdal et al.
2010/0185070	A1	7/2010	Brister et al.	2011/0201911	A1	8/2011	Johnson et al.
2010/0185071	A1	7/2010	Simpson et al.	2011/0218414	A1	9/2011	Kamath
2010/0185072	A1	7/2010	Goode, Jr. et al.	2011/0231107	A1	9/2011	Brauker et al.
2010/0185075	A1	7/2010	Brister et al.	2011/0231140	A1	9/2011	Goode, Jr. et al.
2010/0191082	A1	7/2010	Brister et al.	2011/0231141	A1	9/2011	Goode, Jr. et al.
2010/0198033	A1	8/2010	Krulevitch et al.	2011/0231142	A1	9/2011	Goode, Jr. et al.
2010/0198034	A1	8/2010	Thomas	2011/0253533	A1	10/2011	Shults et al.
2010/0198035	A1	8/2010	Kamath et al.	2011/0257521	A1	10/2011	Fraden
2010/0198036	A1	8/2010	Kamath et al.	2011/0257895	A1	10/2011	Brauker et al.
2010/0204653	A1	8/2010	Gryn et al.	2011/0263958	A1	10/2011	Brauker et al.
2010/0212583	A1	8/2010	Brister et al.	2011/0270062	A1	11/2011	Goode, Jr. et al.
2010/0214104	A1	8/2010	Goode, Jr. et al.	2011/0270158	A1	11/2011	Brauker et al.
2010/0217105	A1	8/2010	Yodfat et al.	2011/0275919	A1	11/2011	Petisce et al.
2010/0217557	A1	8/2010	Kamath et al.	2011/0288574	A1	11/2011	Curry et al.
2010/0223013	A1	9/2010	Kamath et al.	2011/0290645	A1	12/2011	Brister et al.
2010/0223022	A1	9/2010	Kamath et al.	2011/0313543	A1	12/2011	Brauker et al.
2010/0223023	A1	9/2010	Kamath et al.	2011/0319729	A1	12/2011	Donnay et al.
2010/0228109	A1	9/2010	Kamath et al.	2011/0319733	A1	12/2011	Stafford
2010/0228497	A1	9/2010	Kamath et al.	2011/0319738	A1	12/2011	Woodruff et al.
2010/0240975	A1	9/2010	Goode, Jr. et al.	2011/0319739	A1	12/2011	Kamath et al.
2010/0240976	A1	9/2010	Goode, Jr. et al.	2011/0320130	A1	12/2011	Valdes et al.
2010/0261987	A1	10/2010	Kamath et al.	2012/0035445	A1	2/2012	Boock et al.
2010/0262201	A1	10/2010	He et al.	2012/0040101	A1	2/2012	Tapsak et al.
2010/0274107	A1	10/2010	Boock et al.	2012/0046534	A1	2/2012	Simpson et al.
2010/0280341	A1	11/2010	Boock et al.	2012/0078071	A1	3/2012	Bohm et al.
2010/0286496	A1	11/2010	Simpson et al.	2012/0095406	A1	4/2012	Gyrn et al.
2010/0298684	A1	11/2010	Leach et al.	2012/0108934	A1	5/2012	Valdes et al.
2010/0324392	A1*	12/2010	Yee A61B 5/14865 600/345	2012/0108983	A1	5/2012	Banet et al.
2010/0324403	A1	12/2010	Brister et al.	2012/0143135	A1	6/2012	Cole et al.
2010/0331642	A1	12/2010	Bruce et al.	2012/0184909	A1	7/2012	Gym et al.
2010/0331644	A1	12/2010	Neale et al.	2012/0296327	A1	11/2012	Hutchins et al.
2010/0331647	A1	12/2010	Shah et al.	2012/0303043	A1	11/2012	Donnay
2010/0331648	A1	12/2010	Kamath et al.	2013/0047981	A1	2/2013	Bacon
2010/0331653	A1	12/2010	Stafford	2013/0060107	A1	3/2013	Crane et al.
2010/0331656	A1	12/2010	Mensing et al.	2013/0079719	A1	3/2013	Gym et al.
2010/0331657	A1	12/2010	Mensing et al.	2013/0137952	A1	5/2013	McCann et al.
2011/0004085	A1	1/2011	Mensing et al.	2013/0150691	A1	6/2013	Pace et al.
2011/0009727	A1	1/2011	Mensing et al.	2014/0079051	A1	3/2014	Lakkis et al.
2011/0021889	A1	1/2011	Hoss et al.	2014/0107581	A1	4/2014	Safabash et al.
2011/0024043	A1	2/2011	Boock et al.	2015/0025338	A1	1/2015	Lee et al.
2011/0024307	A1	2/2011	Simpson et al.	2016/0015303	A1	1/2016	Bernstein et al.
2011/0027127	A1	2/2011	Simpson et al.	2016/0174881	A1	6/2016	Taub
2011/0027453	A1	2/2011	Boock et al.	2016/0302707	A1	10/2016	Pesach et al.
2011/0027458	A1	2/2011	Boock et al.	2016/0331283	A1*	11/2016	Rao A61B 5/1451
2011/0028815	A1	2/2011	Simpson et al.	2016/0331284	A1	11/2016	Pace
				2017/0128007	A1*	5/2017	Hayter G09B 5/02
				2017/0290534	A1	10/2017	Antonio et al.
				2017/0290546	A1	10/2017	Antonio et al.
				2019/0183393	A1	6/2019	Taub et al.
				2020/0196919	A1*	6/2020	Rao A61B 5/14865

(56)

References Cited

U.S. PATENT DOCUMENTS

2020/0329966 A1 10/2020 Valdes et al.
 2020/0352489 A1 11/2020 Hoppe et al.
 2021/0015411 A1 1/2021 Yee et al.
 2021/0030362 A1* 2/2021 Huang A61B 90/03
 2021/0186424 A1* 6/2021 Rodriguez A61B 5/14532
 2021/0378560 A1* 12/2021 Antonio A61B 5/14503
 2022/0117627 A1* 4/2022 Garai A61B 17/3468
 2022/0192552 A1* 6/2022 Feldman A61B 5/14546

FOREIGN PATENT DOCUMENTS

EP 0320109 6/1989
 EP 0353328 2/1990
 EP 0390390 10/1990
 EP 0396788 11/1990
 EP 0286118 1/1995
 EP 1048264 11/2000
 EP 1177802 9/2004
 EP 0987982 1/2007
 EP 2060284 5/2009
 EP 1704889 3/2010
 EP 2201969 3/2011
 EP 2327362 11/2013
 EP 2335587 2/2014
 JP 11-506629 6/1999
 JP 2004-033438 2/2004
 JP 2004-520103 7/2004
 JP 2004-520898 7/2004
 KR 30-00536603 8/2009
 WO WO-1991/015993 10/1991
 WO WO-1992/013271 8/1992
 WO WO-1994/020602 9/1994
 WO WO-1996/025089 8/1996
 WO WO-1996/039977 12/1996
 WO WO-1998/035053 8/1998

WO WO-1998/056293 12/1998
 WO WO-1999/033504 7/1999
 WO WO-1999/056613 11/1999
 WO WO-2000/049940 8/2000
 WO WO-2000/059370 10/2000
 WO WO-2000/078992 12/2000
 WO WO-2001/052935 7/2001
 WO WO-2001/054753 8/2001
 WO WO-2002/016905 2/2002
 WO WO-2002/050534 6/2002
 WO WO-2002/058537 8/2002
 WO WO-2003/028784 4/2003
 WO WO-2003/076893 9/2003
 WO WO-2003/082091 10/2003
 WO WO-2004/028337 4/2004
 WO WO-2004/060436 7/2004
 WO WO-2004/061420 7/2004
 WO WO-2004/098684 11/2004
 WO 2004103170 12/2004
 WO WO-2004/112602 12/2004
 WO WO-2005/084534 9/2005
 WO WO-2005/089103 9/2005
 WO WO-2006/024671 3/2006
 WO WO-2006/042811 4/2006
 WO WO-2006/108809 10/2006
 WO WO-2007/089738 8/2007
 WO WO-2007/140783 12/2007
 WO WO-2008/065646 6/2008
 WO 2008105768 9/2008
 WO WO-2008/133702 11/2008
 WO WO-2009/016638 2/2009
 WO WO-2009/062675 5/2009
 WO WO-2010/112521 10/2010
 WO WO-2011/002815 1/2011
 WO WO D214177-001 * 5/2021
 WO WO D214177-002 * 5/2021
 WO WO D214177-004 * 5/2021

* cited by examiner

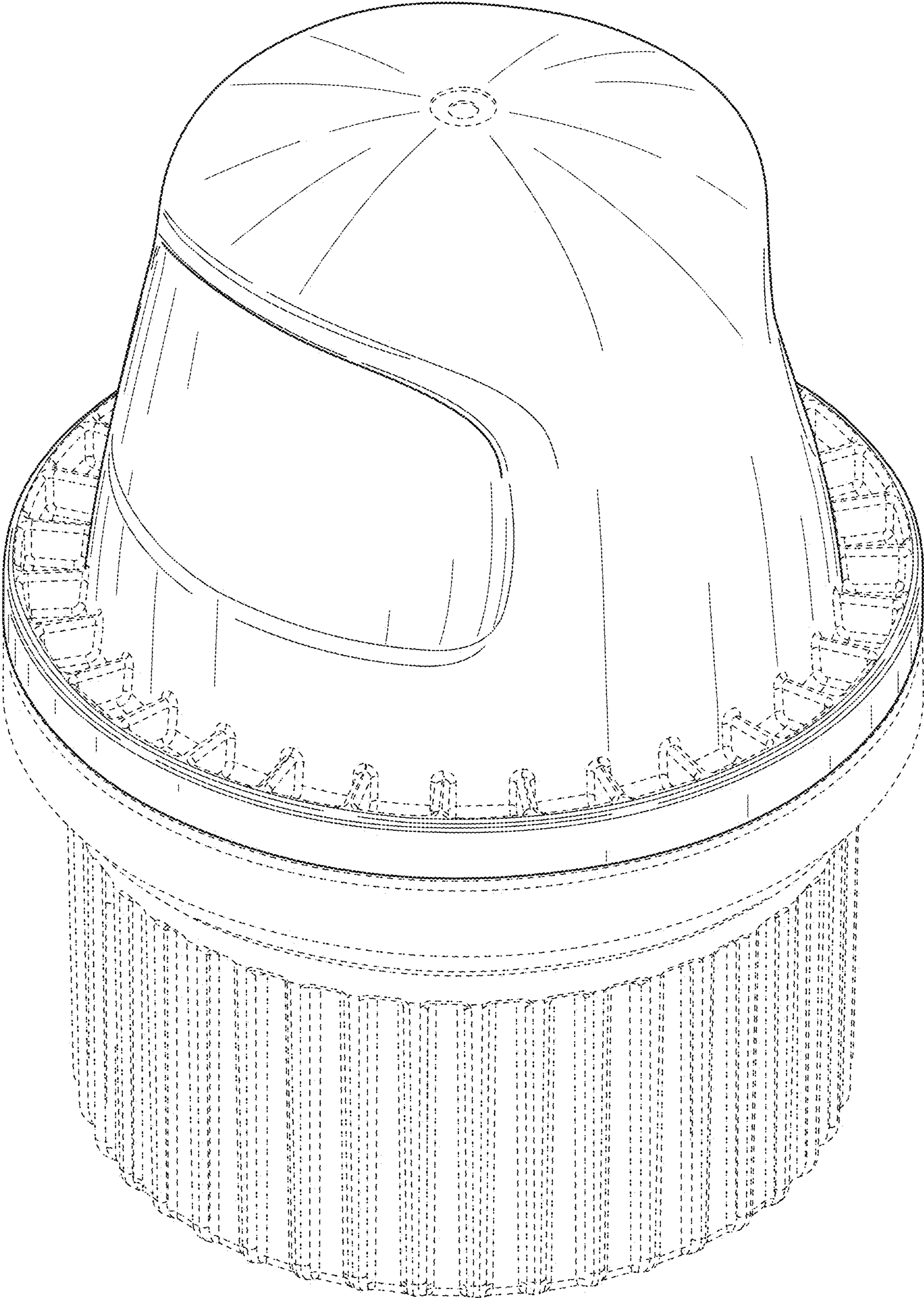

FIG. 1

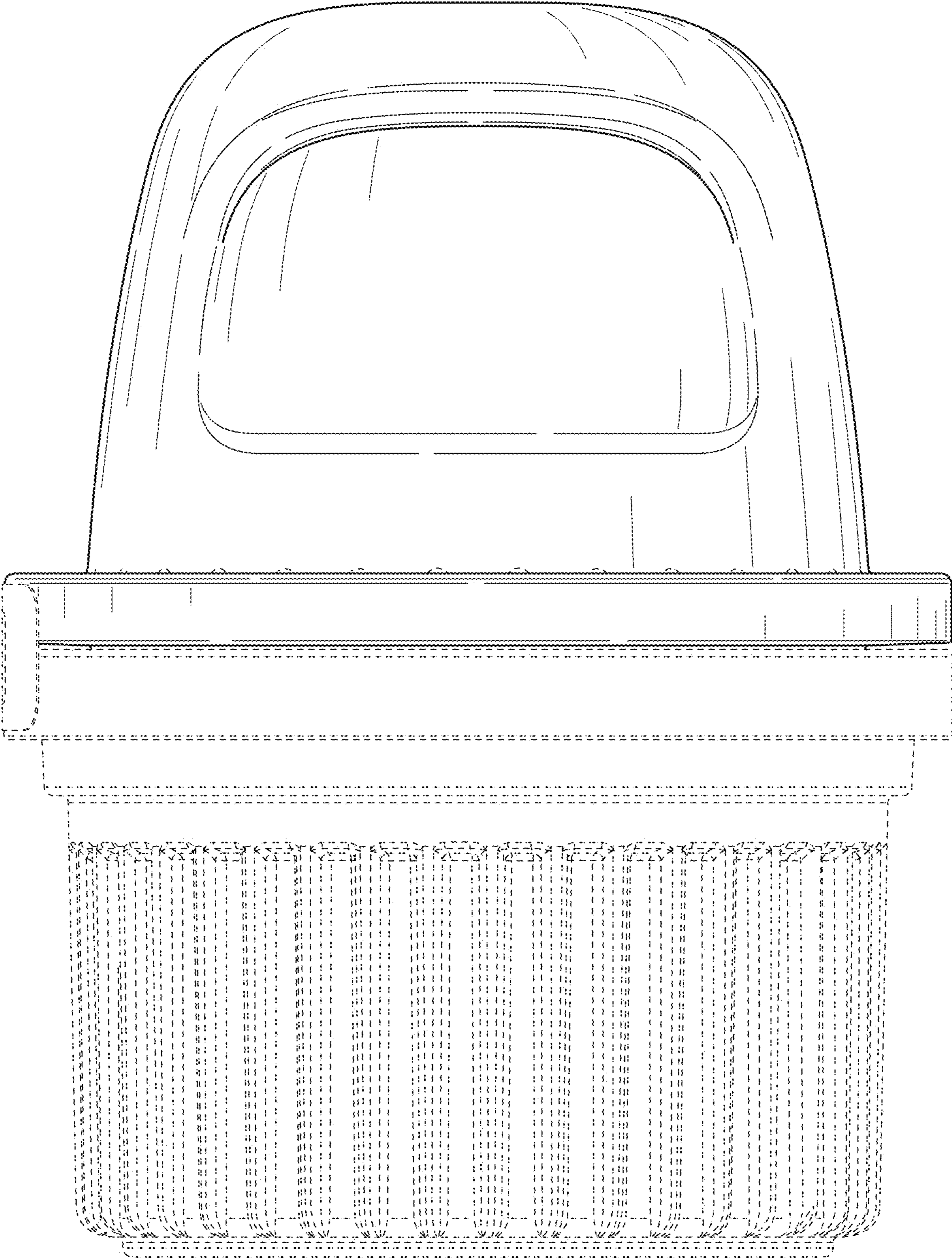

FIG. 2

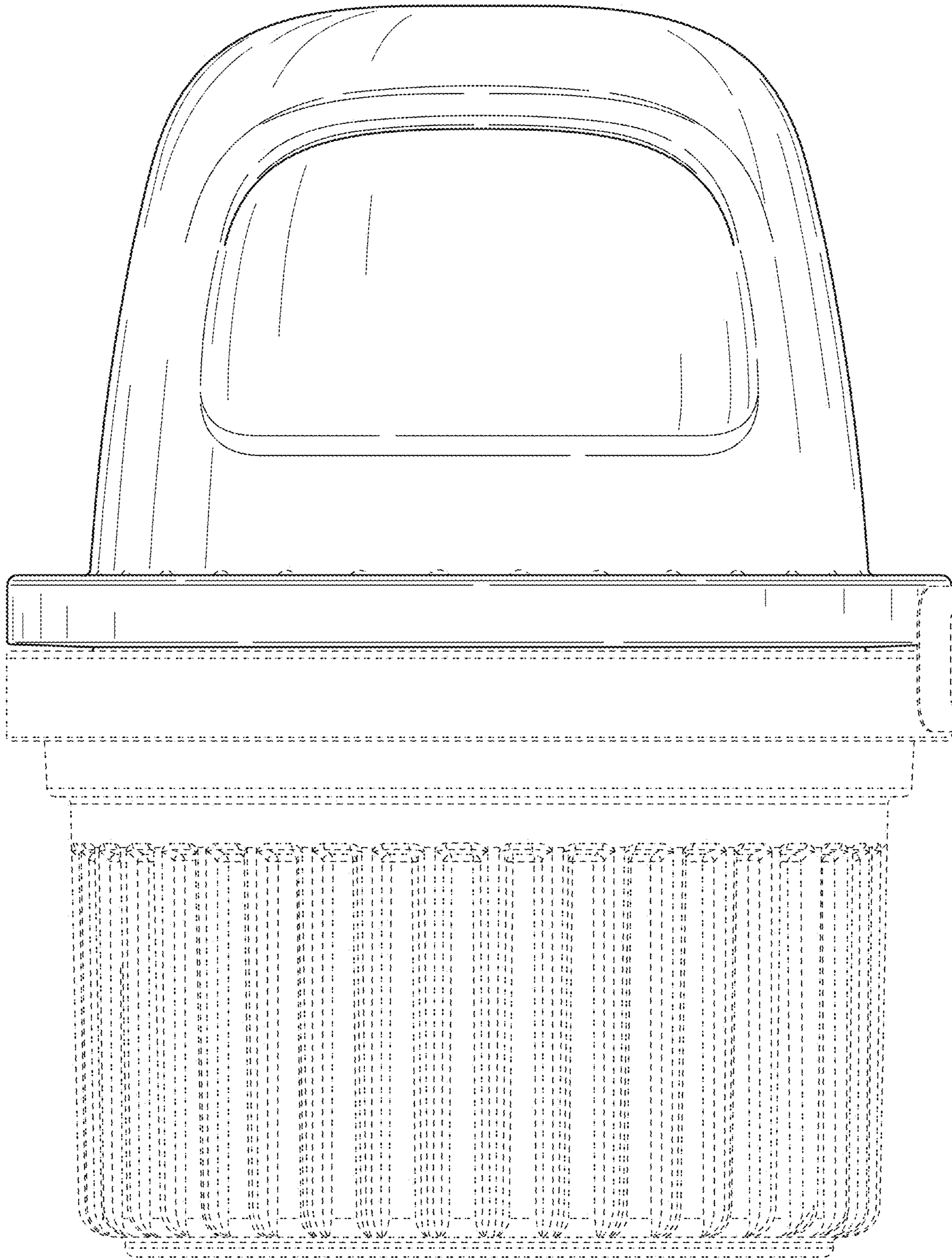

FIG. 3

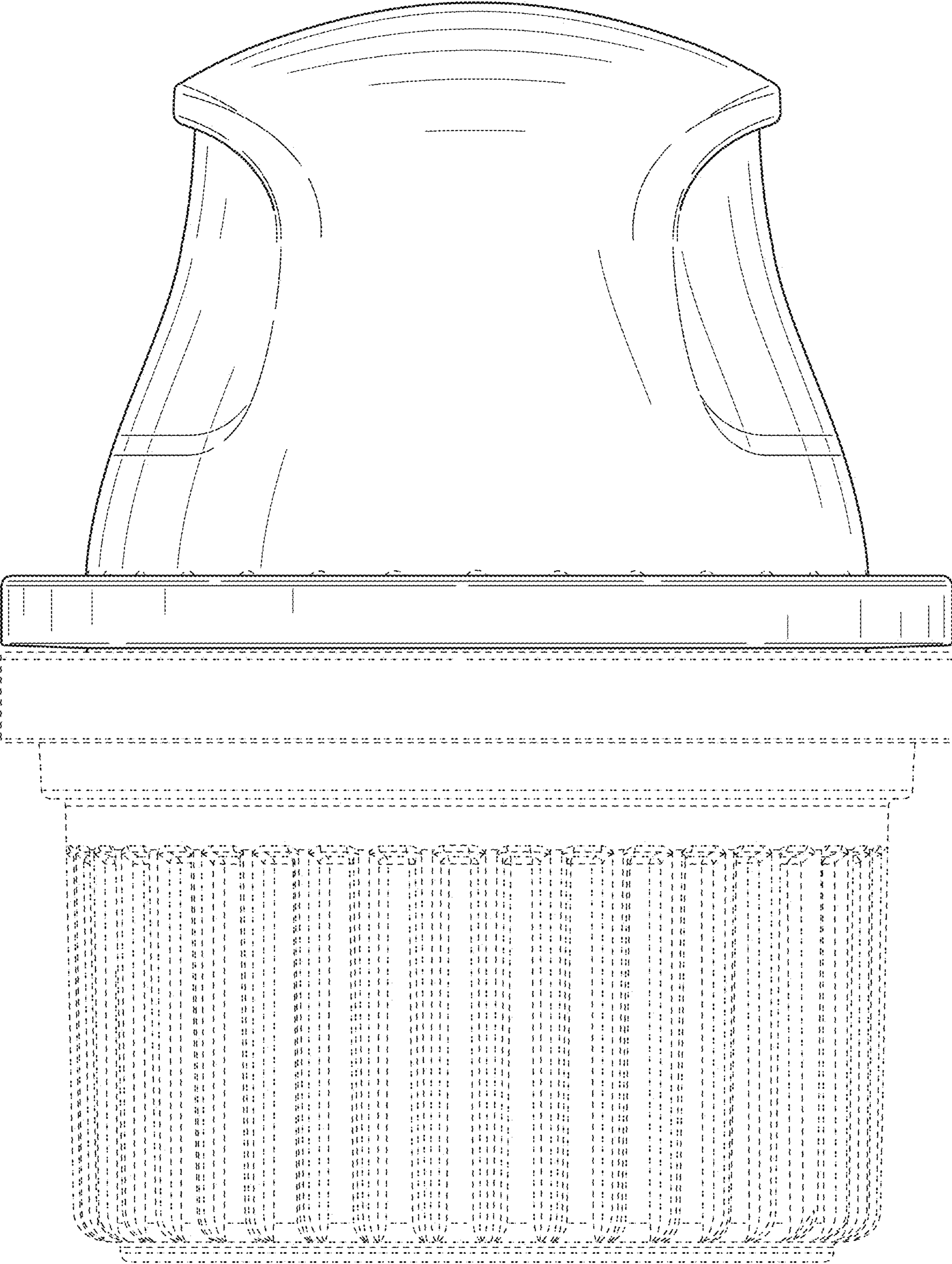

FIG. 4

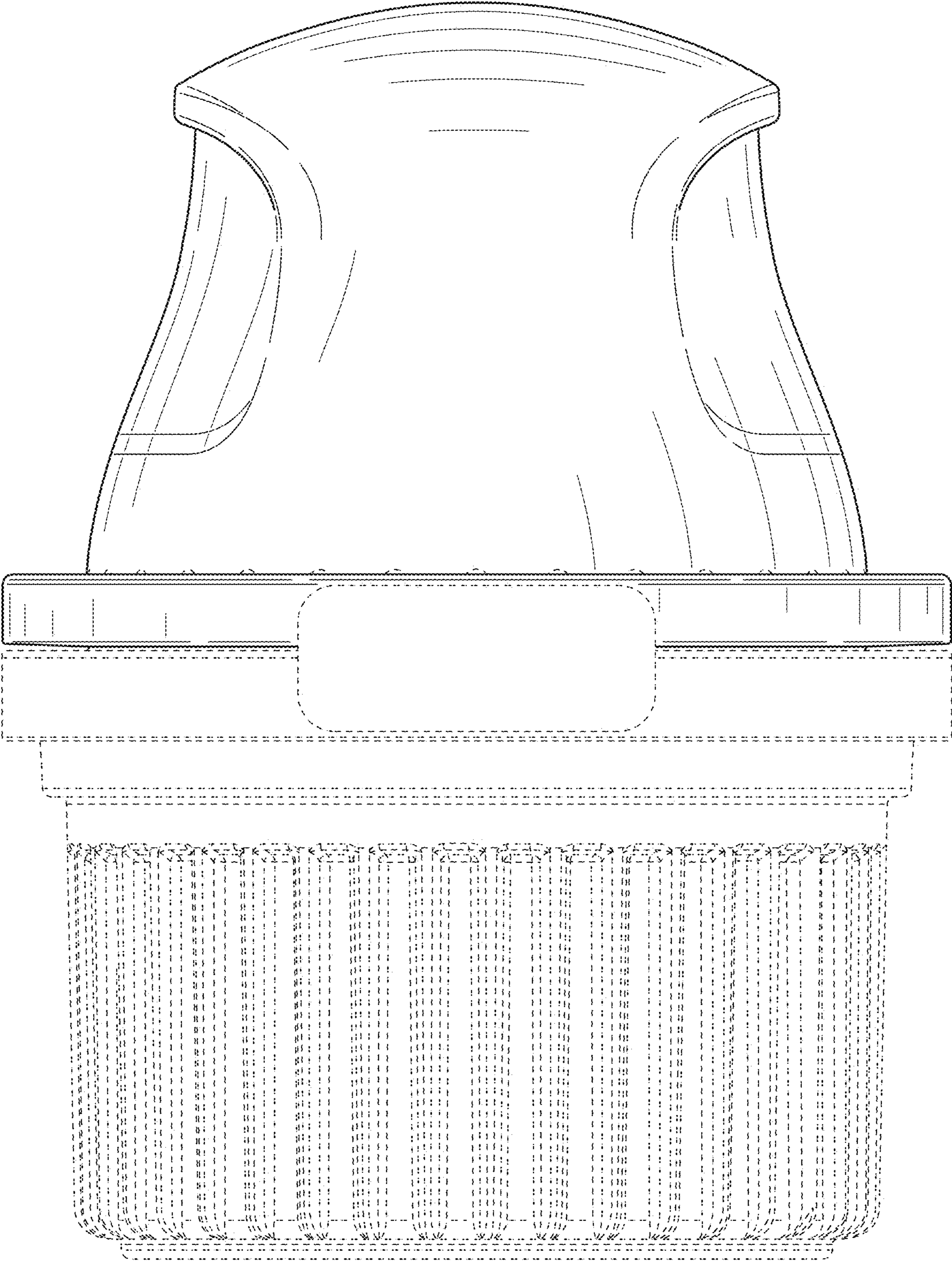

FIG. 5

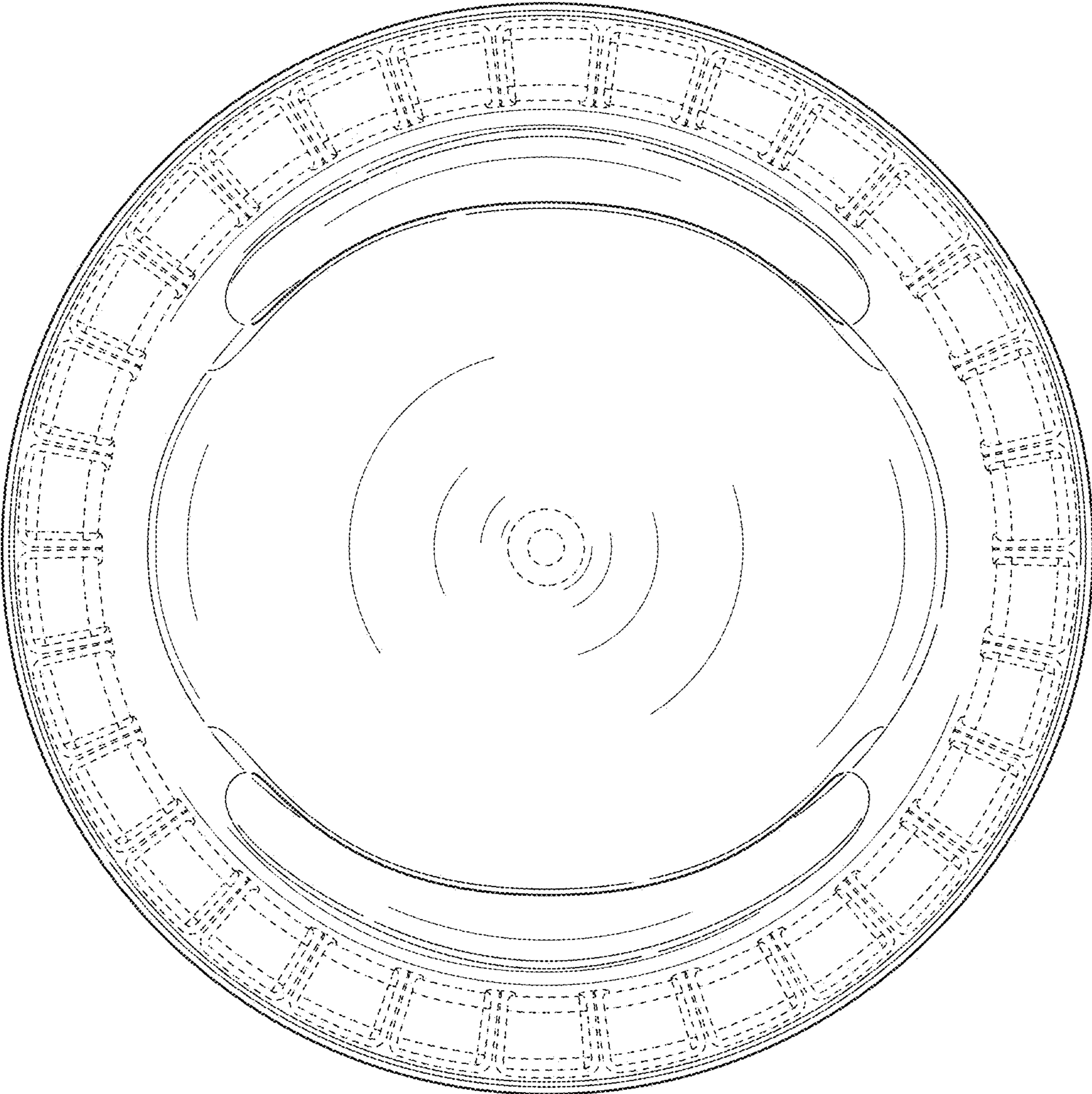

FIG. 6

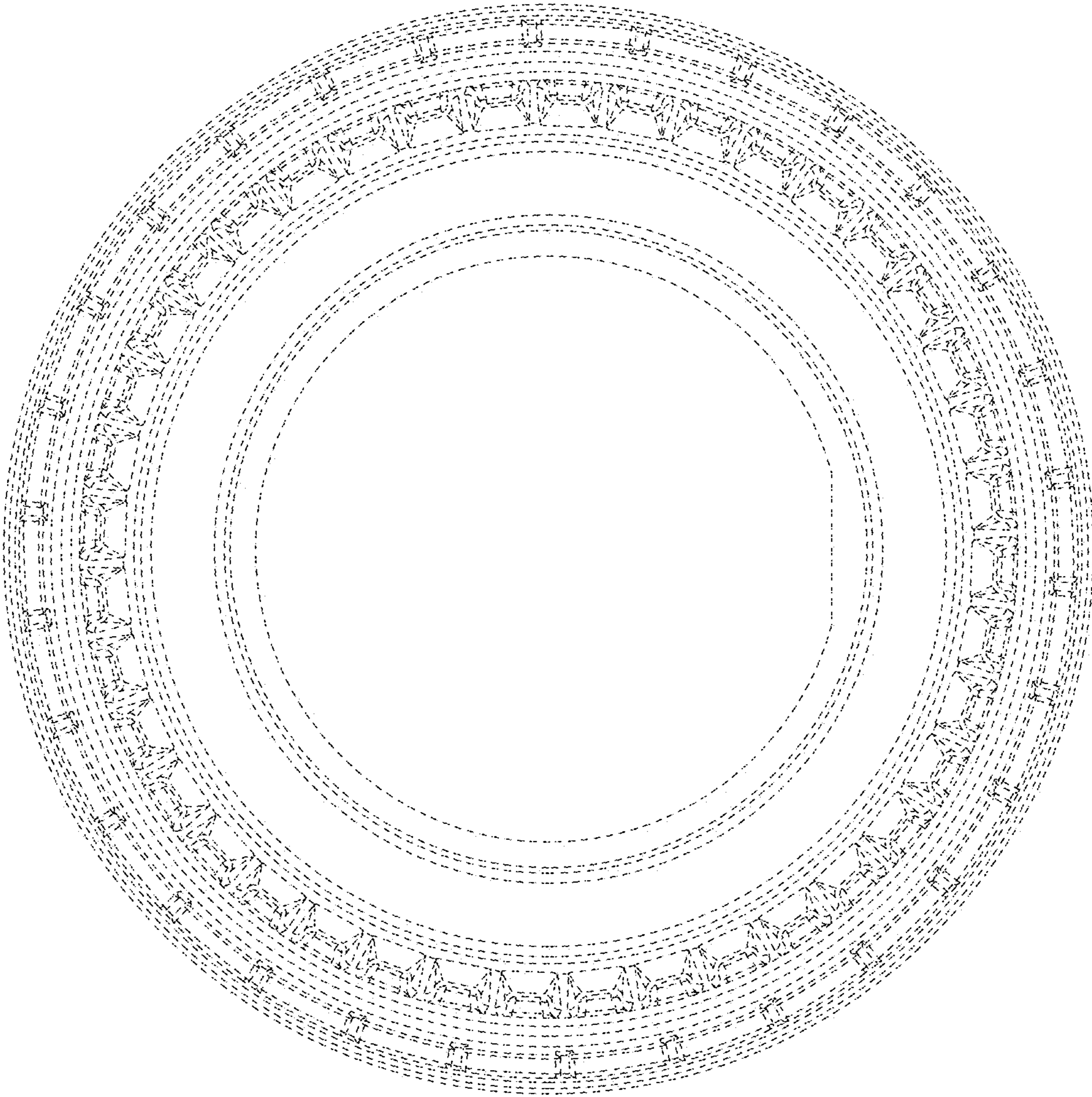

FIG. 7

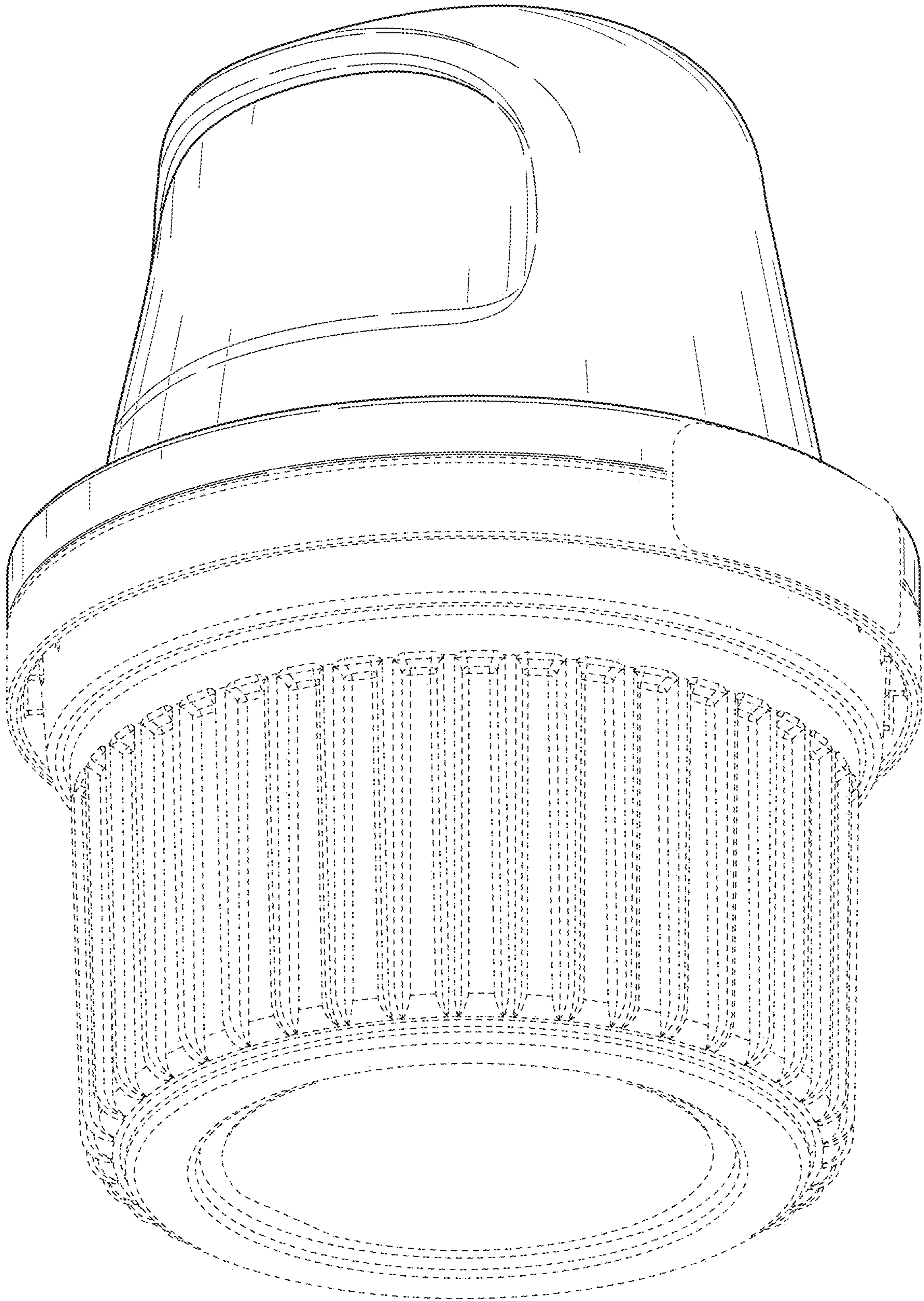

FIG. 8