



US00D982623S

(12) **United States Design Patent**
Liang et al.

(10) **Patent No.:** **US D982,623 S**

(45) **Date of Patent:** **** Apr. 4, 2023**

(54) **HEAT PRESS MACHINE**

(71) Applicant: **Guangzhou Jingwushi Information Technology Co., Ltd.**, Guangdong (CN)

(72) Inventors: **Yudong Liang**, Guangdong (CN); **De Zhang**, Guangdong (CN)

(73) Assignee: **Guangzhou Jingwushi Information Technology Co., Ltd.**, Guangzhou (CN)

(**) Term: **15 Years**

(21) Appl. No.: **29/812,378**

(22) Filed: **Oct. 21, 2021**

(30) **Foreign Application Priority Data**

Sep. 30, 2021 (CN) 202130655242.5

(51) **LOC (14) Cl.** **15-09**

(52) **U.S. Cl.**
USPC **D15/122**

(58) **Field of Classification Search**

USPC D15/122, 123, 145, 146; D32/70
CPC B30B 1/04; B30B 15/04; B30B 15/18;
B30B 15/048; B30B 15/064; B30B
15/287; B30B 15/0094; B32B 37/06;
B32B 37/0053; B32B 2309/02; B41F
16/00; B41F 16/02; B41F 16/026

See application file for complete search history.

(56) **References Cited**

U.S. PATENT DOCUMENTS

8,418,739 B2 * 4/2013 Robinson B30B 15/028
156/359
D728,885 S * 5/2015 Dierker D32/70

D873,313 S * 1/2020 Galkin D15/123
D875,149 S * 2/2020 Galkin D15/122
D893,563 S * 8/2020 Crisp D15/122
D893,566 S * 8/2020 Chen D15/122
D925,621 S * 7/2021 Crisp D32/70
D927,577 S * 8/2021 Galkin D15/122
D935,494 S * 11/2021 Chen D32/70
D939,171 S * 12/2021 Zheng D32/70
D952,009 S * 5/2022 Ai D32/70
D955,080 S * 6/2022 Guo D32/70
D965,043 S * 9/2022 Chen D32/70
D974,420 S * 1/2023 Wang D15/122
2017/0314177 A1 * 11/2017 Komiya D06C 15/10
2019/0184667 A1 * 6/2019 Cao B30B 1/04

* cited by examiner

Primary Examiner — Patricia A Palasik

(57) **CLAIM**

The ornamental design for a heat press machine, as shown and described.

DESCRIPTION

FIG. 1 is a front, top and right side perspective view of a heat press machine showing our new design;
FIG. 2 is a rear, bottom and left side perspective view thereof;
FIG. 3 is a front elevational view thereof;
FIG. 4 is a rear elevational view thereof;
FIG. 5 is a left side view thereof;
FIG. 6 is a right side view thereof;
FIG. 7 is a top plan view thereof; and,
FIG. 8 is a bottom plan view thereof.

The broken lines in the drawings illustrate portions of the heat press machine which form no part of the claimed design.

1 Claim, 8 Drawing Sheets

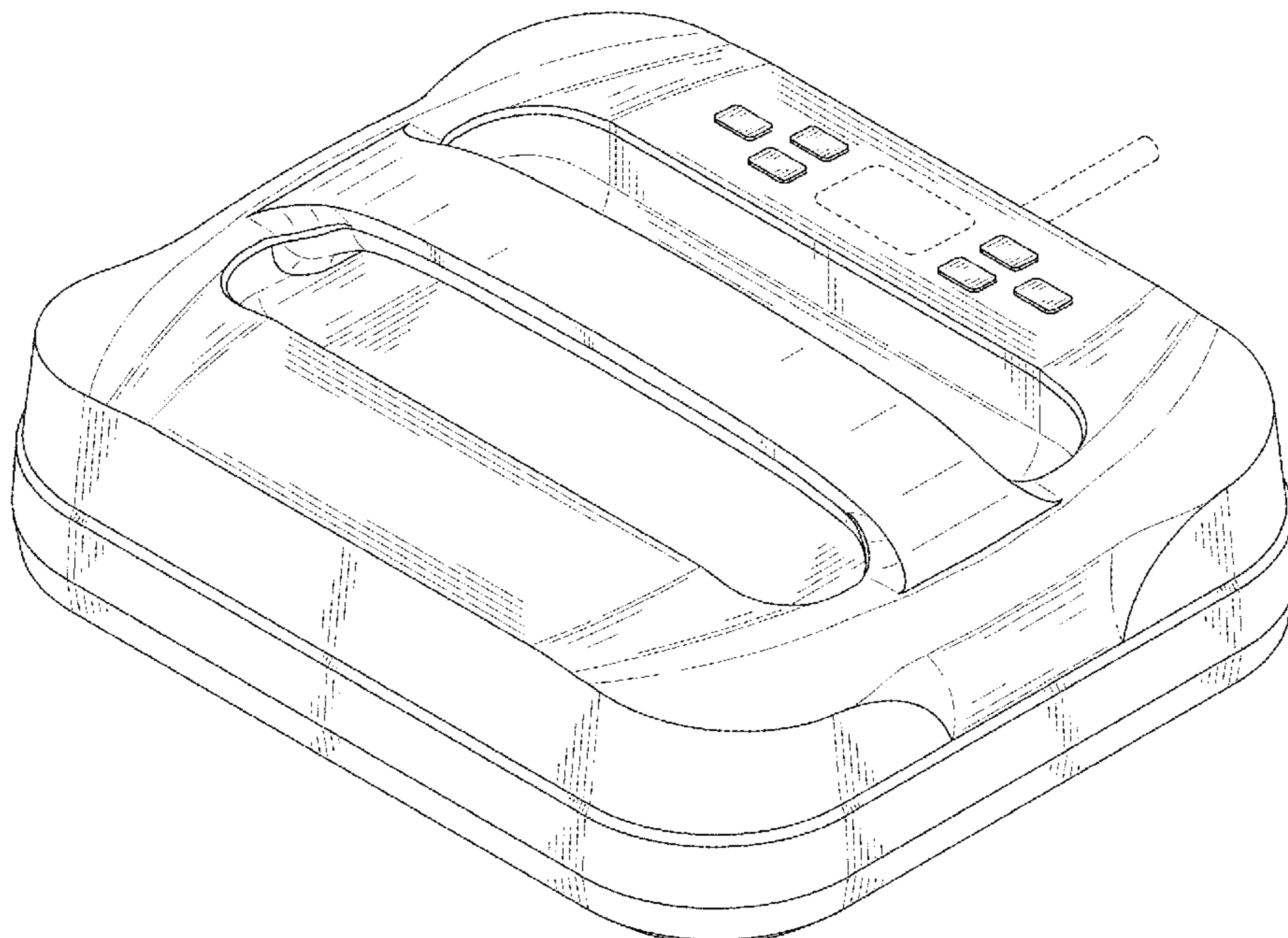

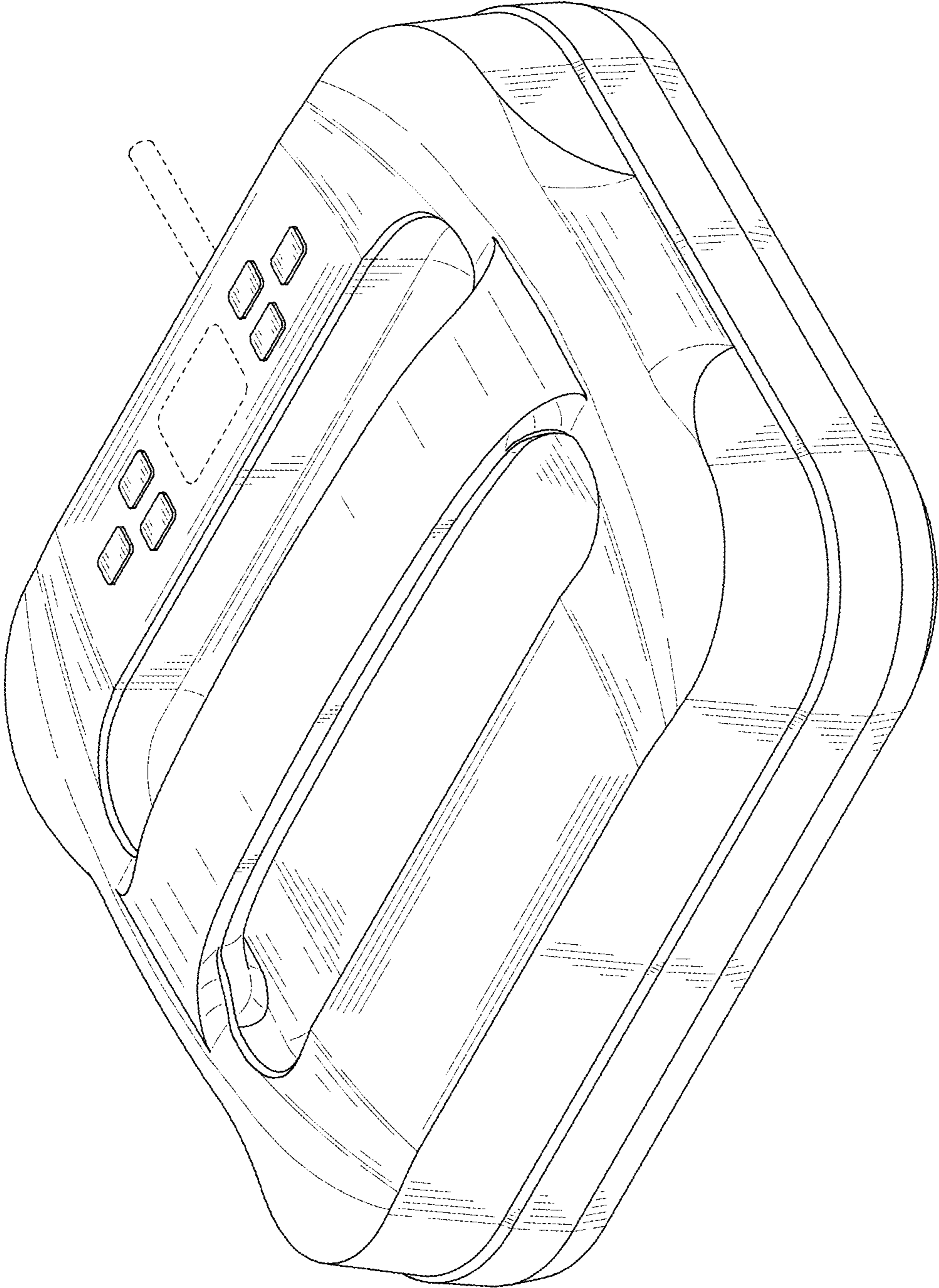

FIG. 1

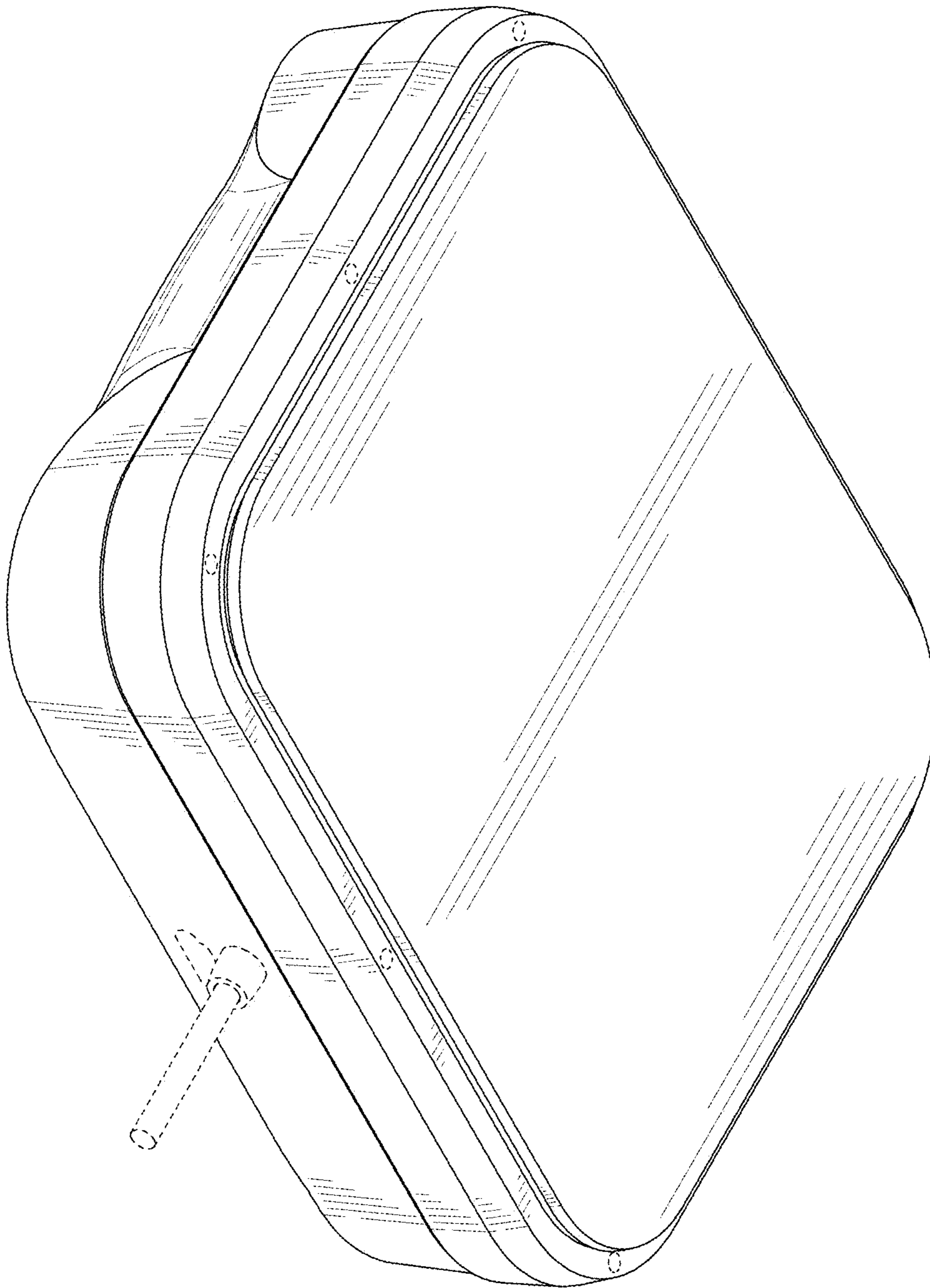

FIG. 2

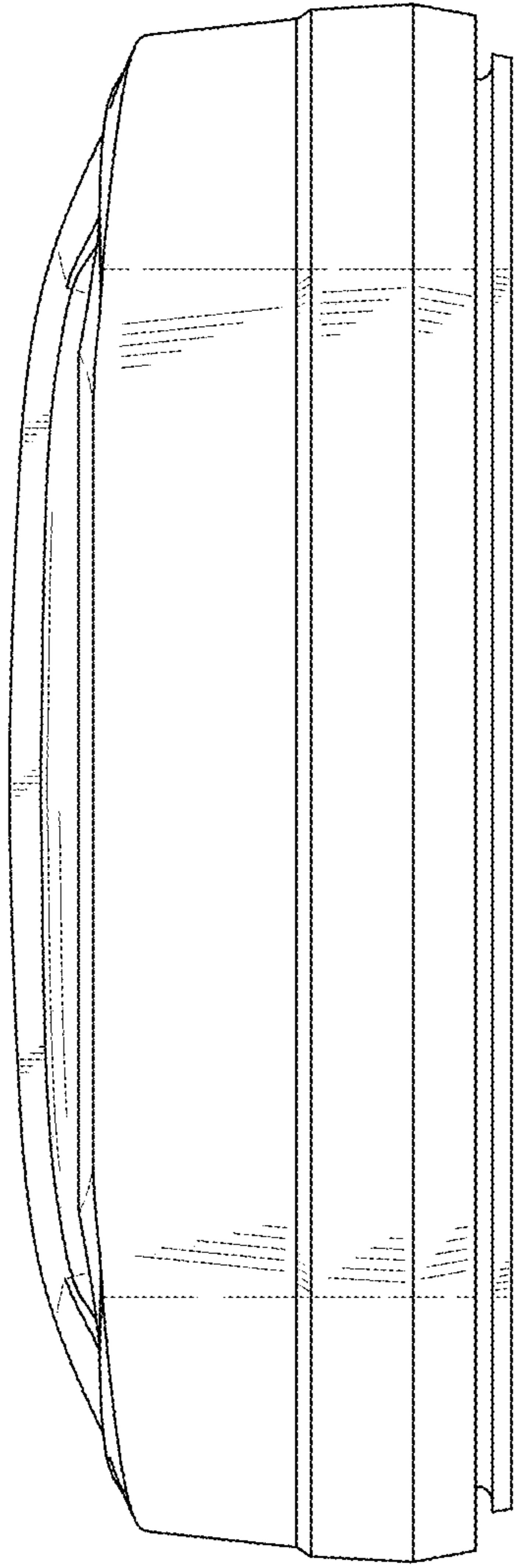

FIG. 3

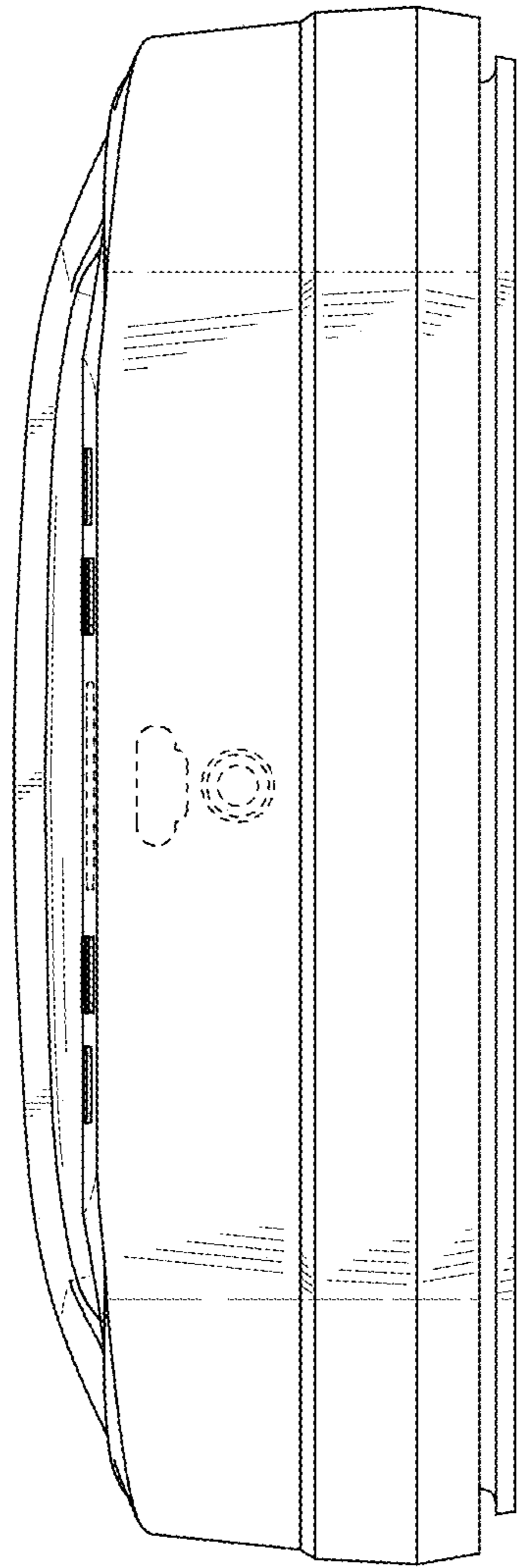

FIG. 4

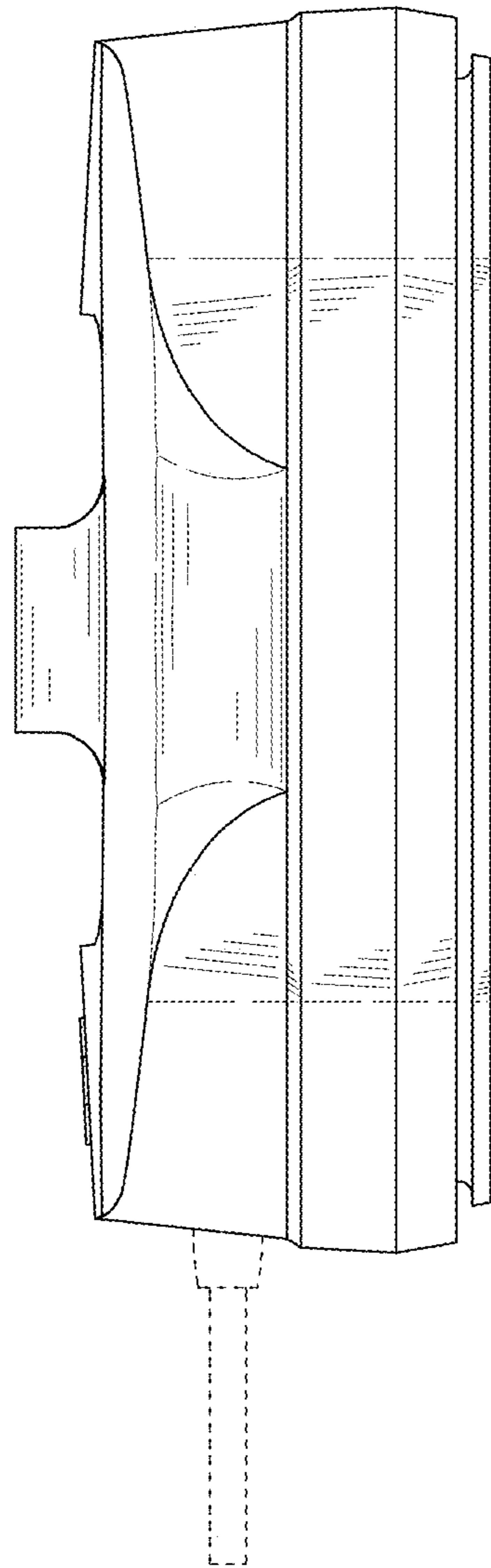

FIG. 5

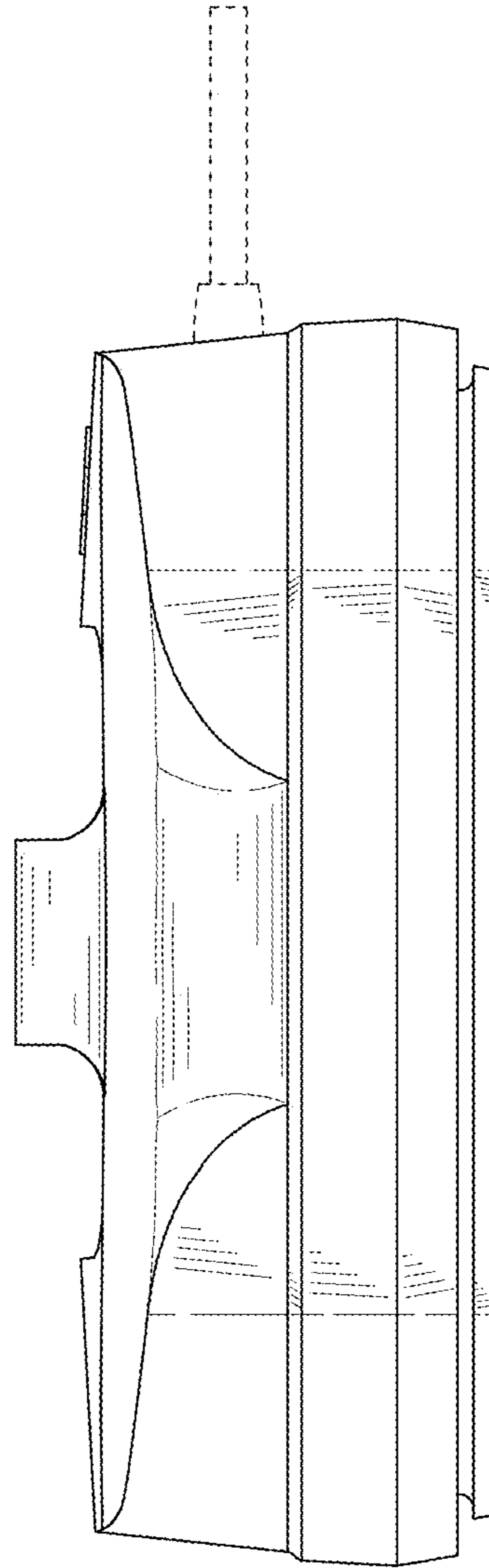

FIG. 6

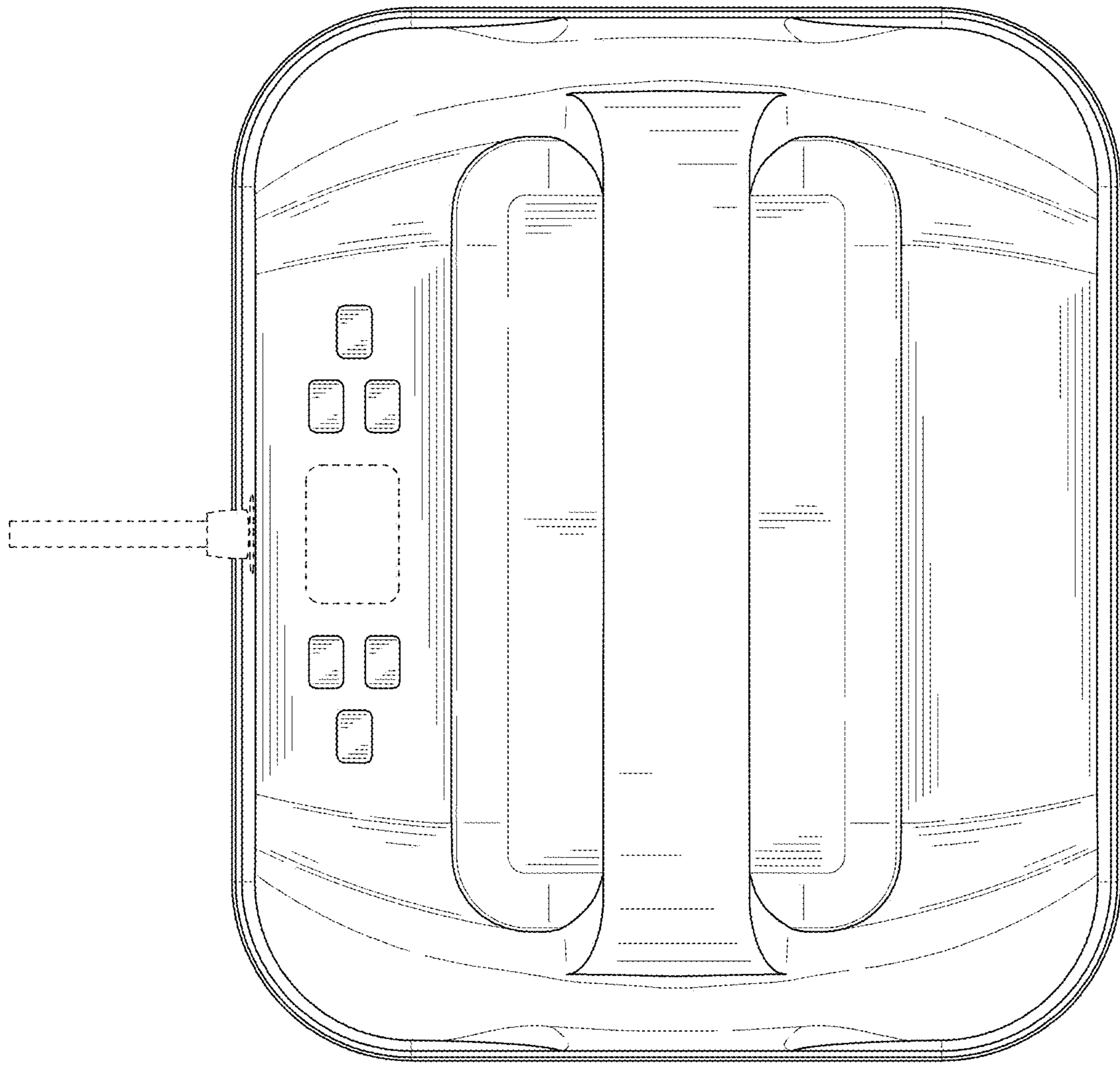

FIG. 7

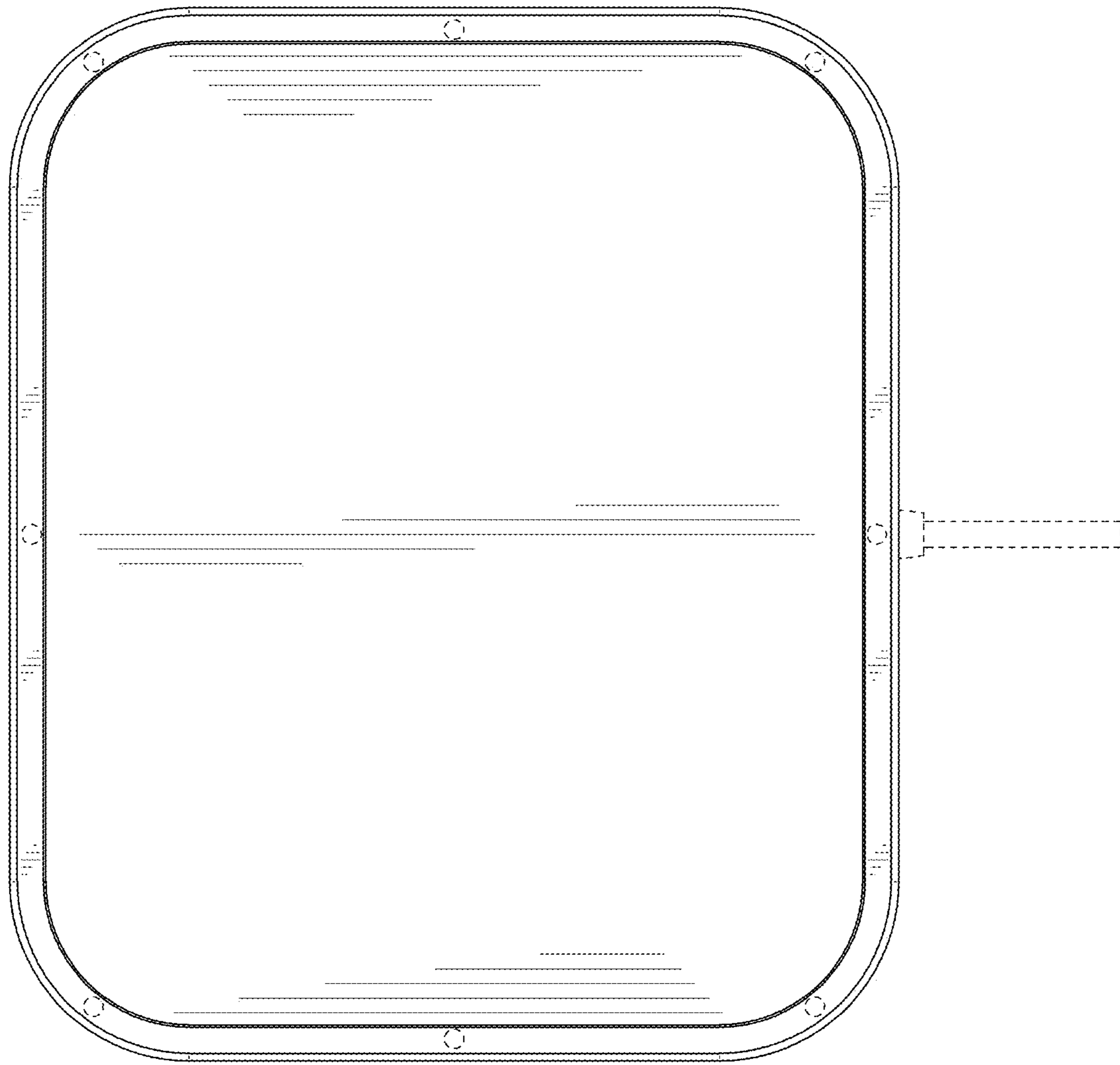

FIG. 8