



US00D982484S

(12) **United States Design Patent**  
**Feng et al.**

(10) **Patent No.:** **US D982,484 S**  
(45) **Date of Patent:** **\*\* Apr. 4, 2023**

- (54) **ELECTRIC TRICYCLE**
- (71) Applicant: **HUAIAN PX INDUSTRIAL DESIGN CO., LTD**, Huai'an (CN)
- (72) Inventors: **Ruizhuan Feng**, Huaian (CN);  
**Yonghua Cao**, Tongzhou (CN);  
**Jingjing Fan**, Lianyungang (CN)
- (73) Assignee: **HUAIAN PX INDUSTRIAL DESIGN CO., LTD**, Huai'an (CN)

(\*\*) Term: **15 Years**

(21) Appl. No.: **29/814,163**

(22) Filed: **Nov. 3, 2021**

(51) **LOC (14) Cl.** ..... **12-11**

(52) **U.S. Cl.**  
USPC ..... **D12/112**

(58) **Field of Classification Search**  
USPC ..... D12/1, 107, 110, 111, 114, 117;  
D21/412, 414, 419, 423, 424, 425, 426,  
D21/427, 428, 431, 432, 433, 434, 435  
CPC . B62K 3/00; B62K 3/002; B62K 3/02; B62K  
3/04; B62K 3/06; B62K 3/10; B62K  
5/02; B62K 5/06; B62K 5/08  
See application file for complete search history.

(56) **References Cited**

**U.S. PATENT DOCUMENTS**

- 3,746,118 A \* 7/1973 Altorfer ..... B62D 61/065  
280/267
- D352,921 S \* 11/1994 Pepe ..... D21/423
- D476,042 S \* 6/2003 Hsieh ..... D21/423
- 6,840,527 B1 \* 1/2005 Michelau ..... B62K 21/00  
280/270

- D533,601 S \* 12/2006 Moreira ..... D21/423
- D777,609 S \* 1/2017 Loc ..... D12/112
- D813,102 S 3/2018 Talios et al.
- D845,837 S \* 4/2019 Jin ..... D12/112
- D921,537 S \* 6/2021 Letema ..... D12/112
- 2017/0190377 A1\* 7/2017 Ku ..... B62J 1/04

**OTHER PUBLICATIONS**

PXID F2, Published date unavailable [online], [retrieved on Aug. 29, 2022]. Retrieved from the Internet: <https://limeeo.com/products/pxid-f-2> (Year: 2022).\*

\* cited by examiner

*Primary Examiner* — Cary M Robinson  
*Assistant Examiner* — Adam C Mager

(57) **CLAIM**

The ornamental design for an electric tricycle, as shown and described.

**DESCRIPTION**

FIG. 1 is a perspective view of an electric tricycle showing our new design;  
FIG. 2 is another perspective view thereof;  
FIG. 3 is a front elevational view thereof;  
FIG. 4 is a rear elevational view thereof;  
FIG. 5 is a left side elevational view thereof;  
FIG. 6 is a right side elevational view thereof;  
FIG. 7 is a top plan view thereof;  
FIG. 8 is a bottom plan view thereof; and,  
FIG. 9 is an enlarged view of portion 9 shown in FIG. 1.  
The dash-dash broken lines in the drawings depict portions of the electric tricycle that form no part of the claimed design. The dot-dash broken lines represent the boundary of the enlarged portion and form no part of the claimed design.

**1 Claim, 9 Drawing Sheets**

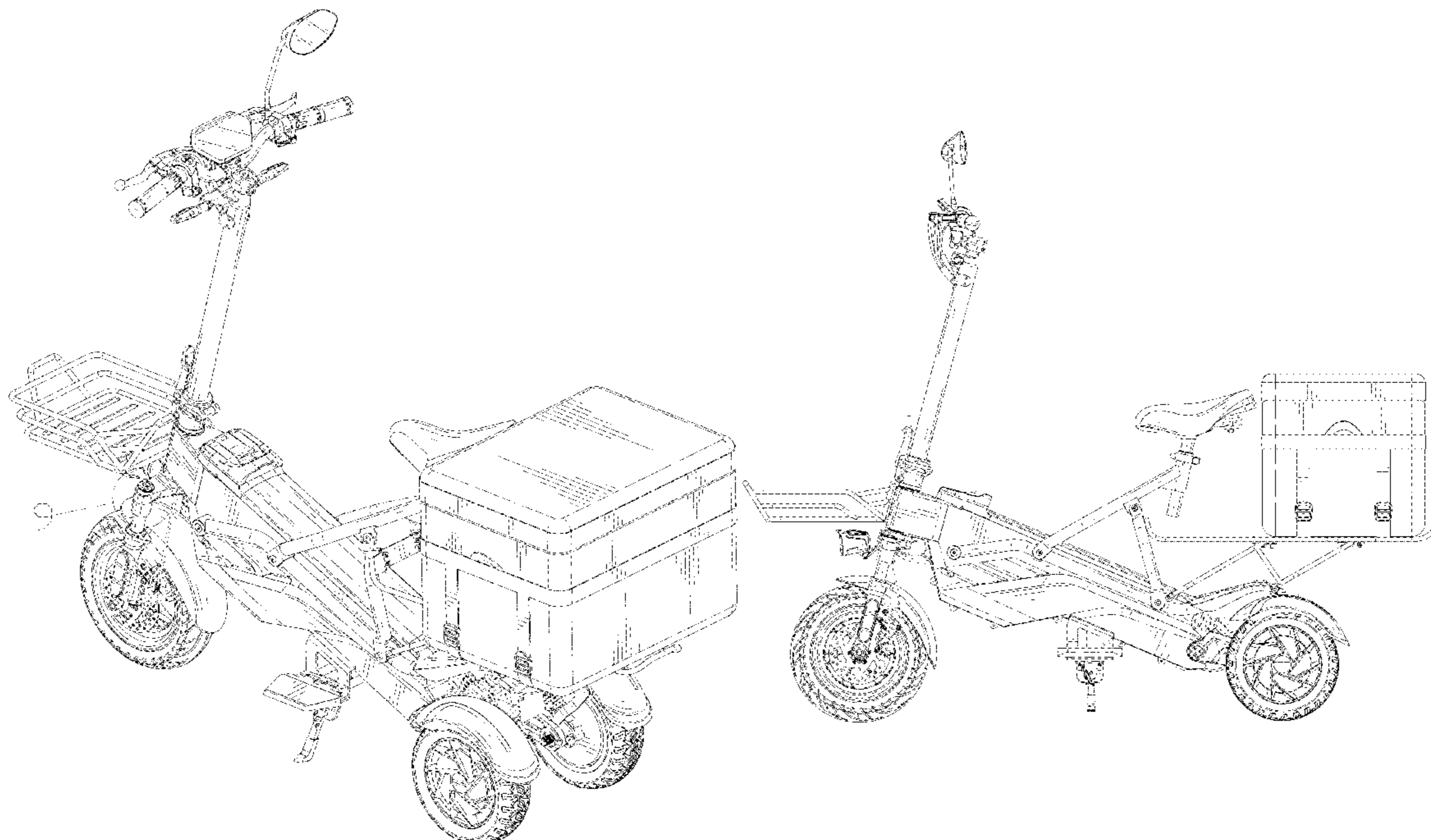

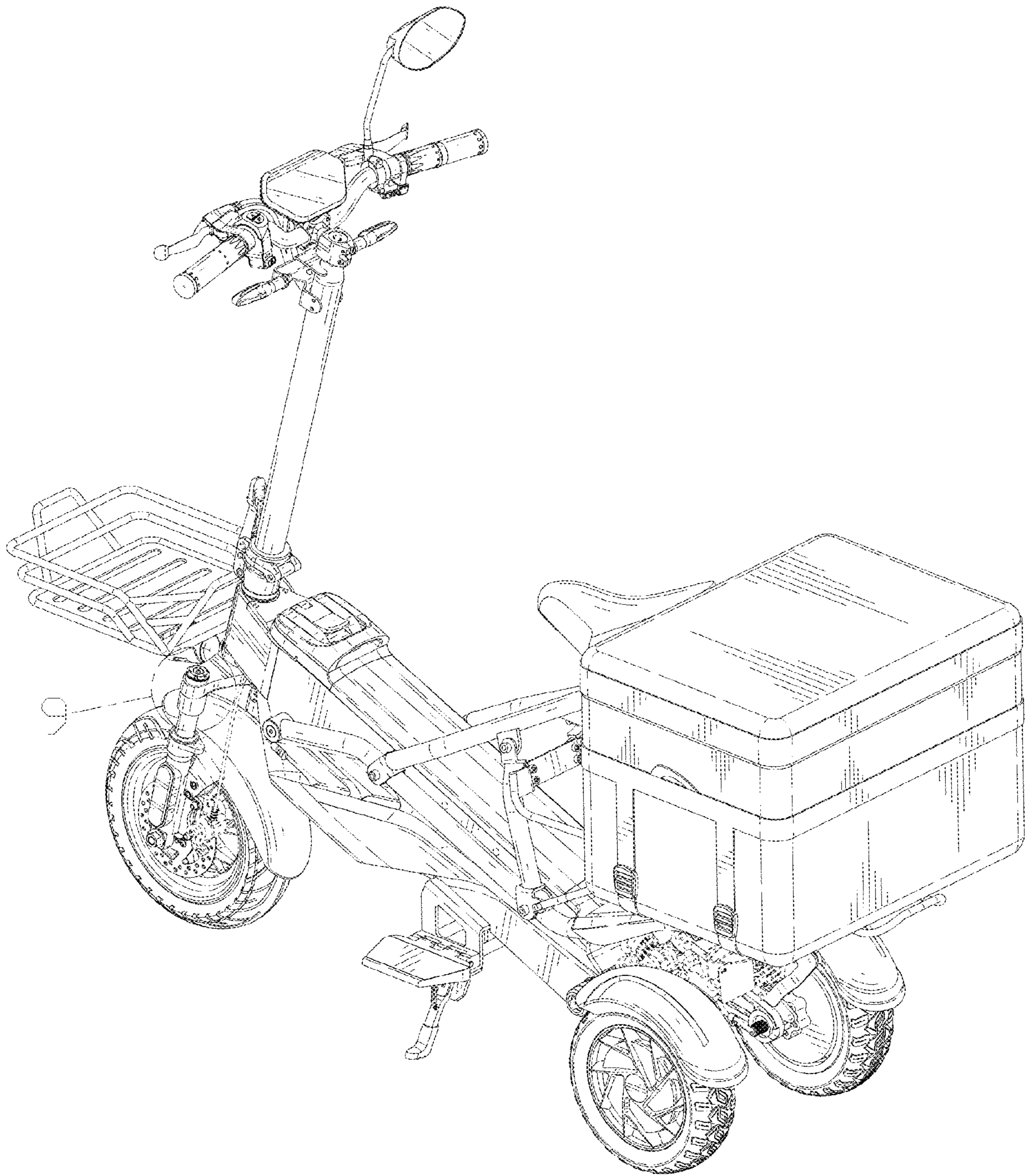

FIG. 1

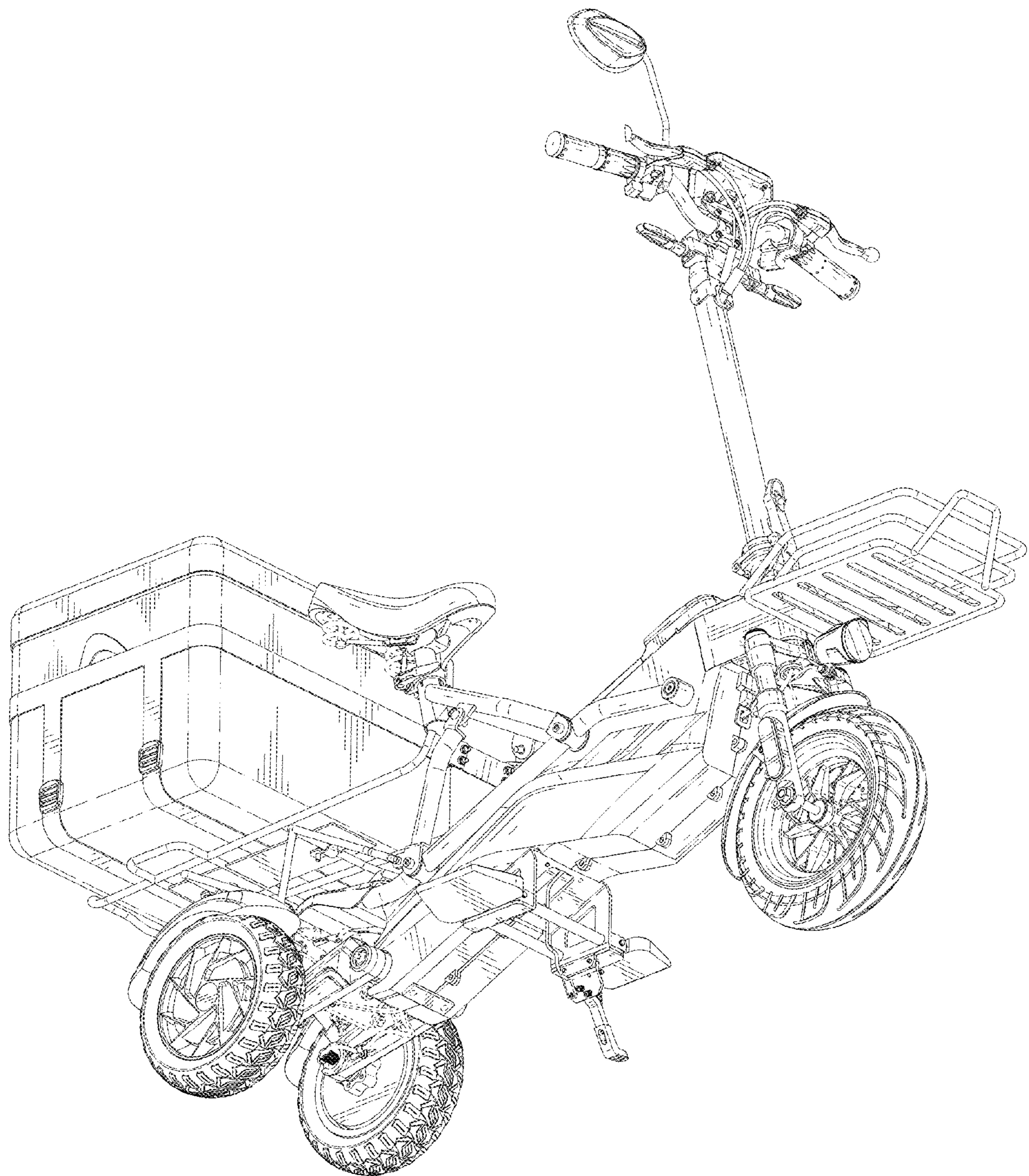

FIG. 2

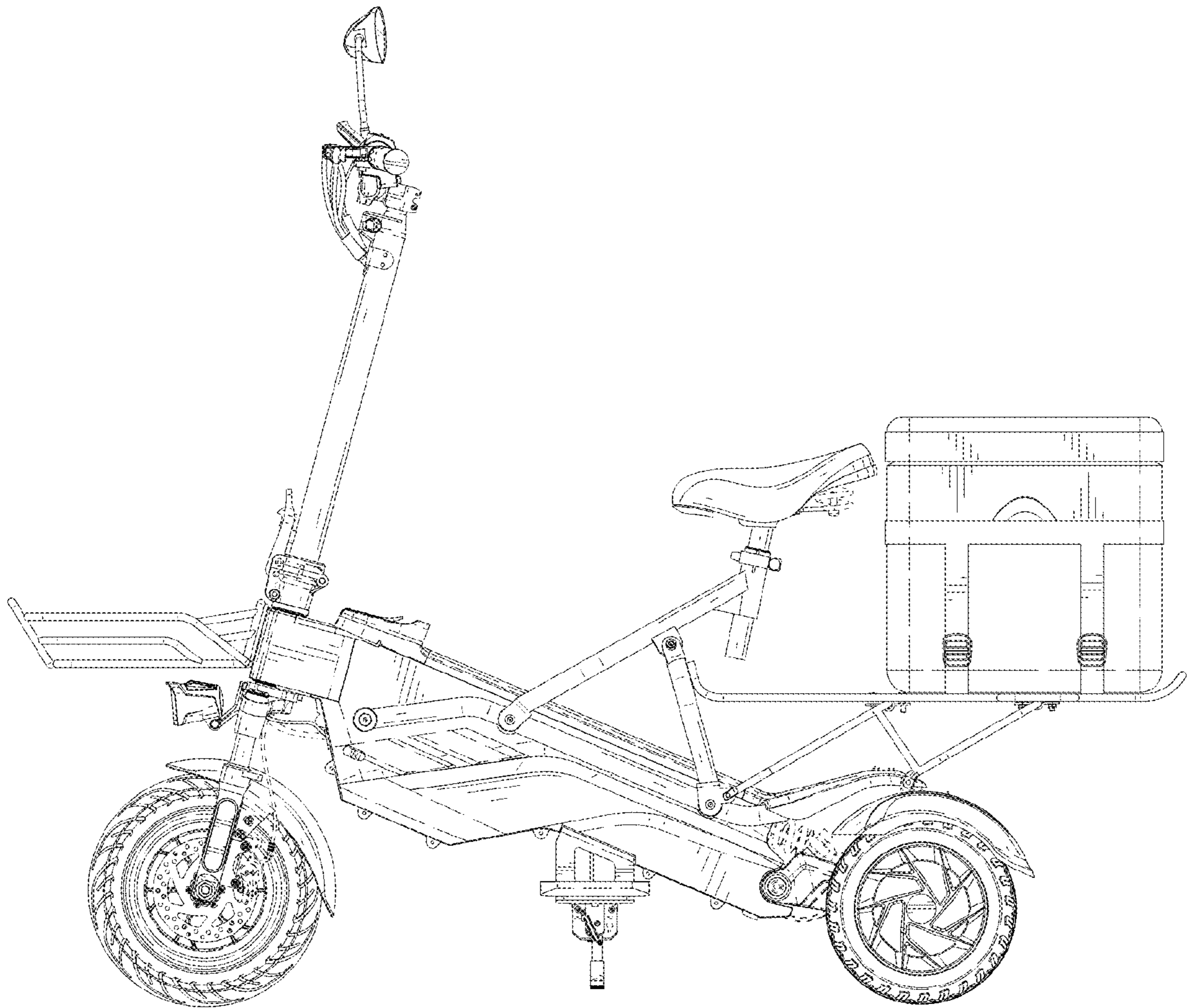

FIG. 3

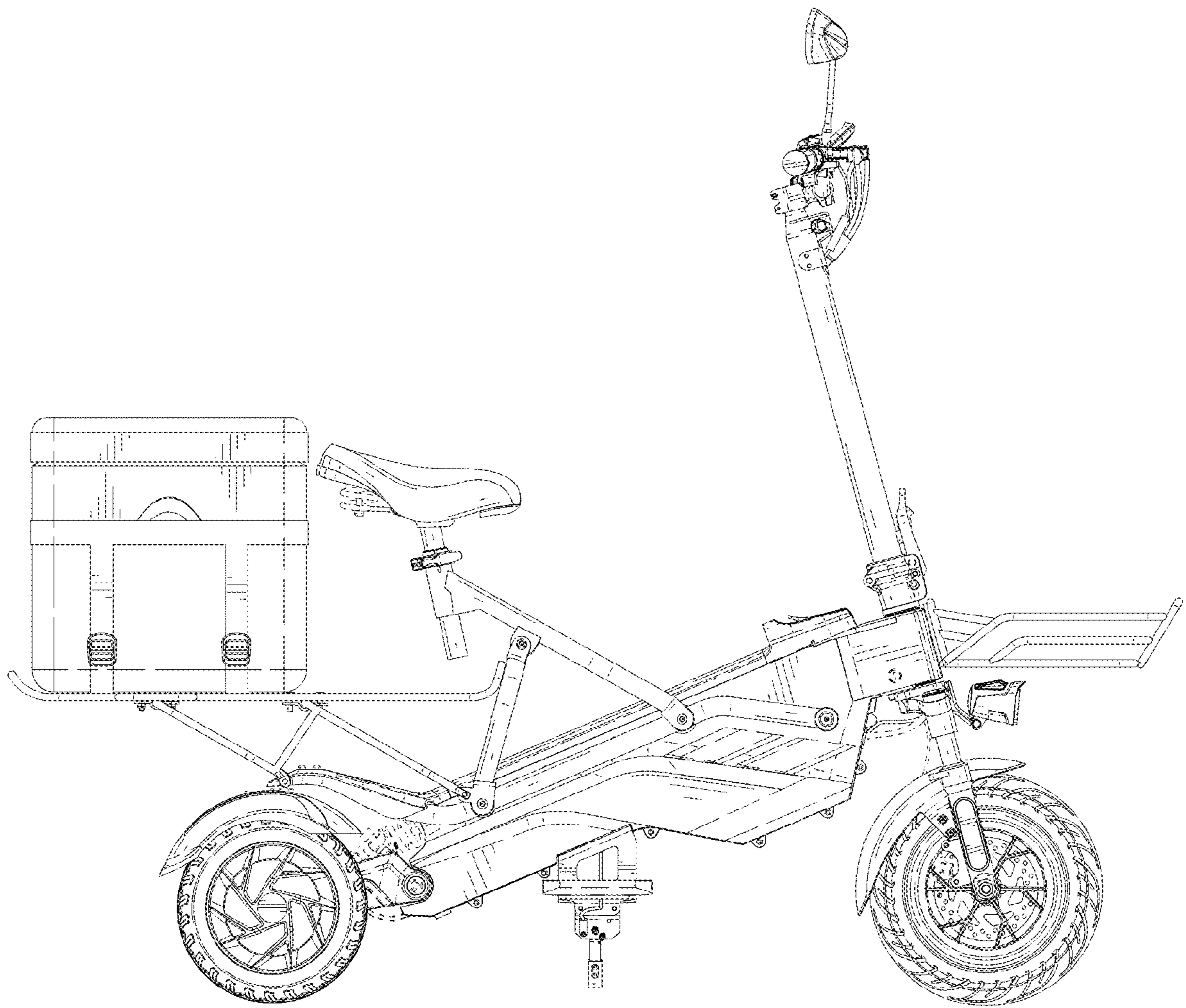

FIG. 4

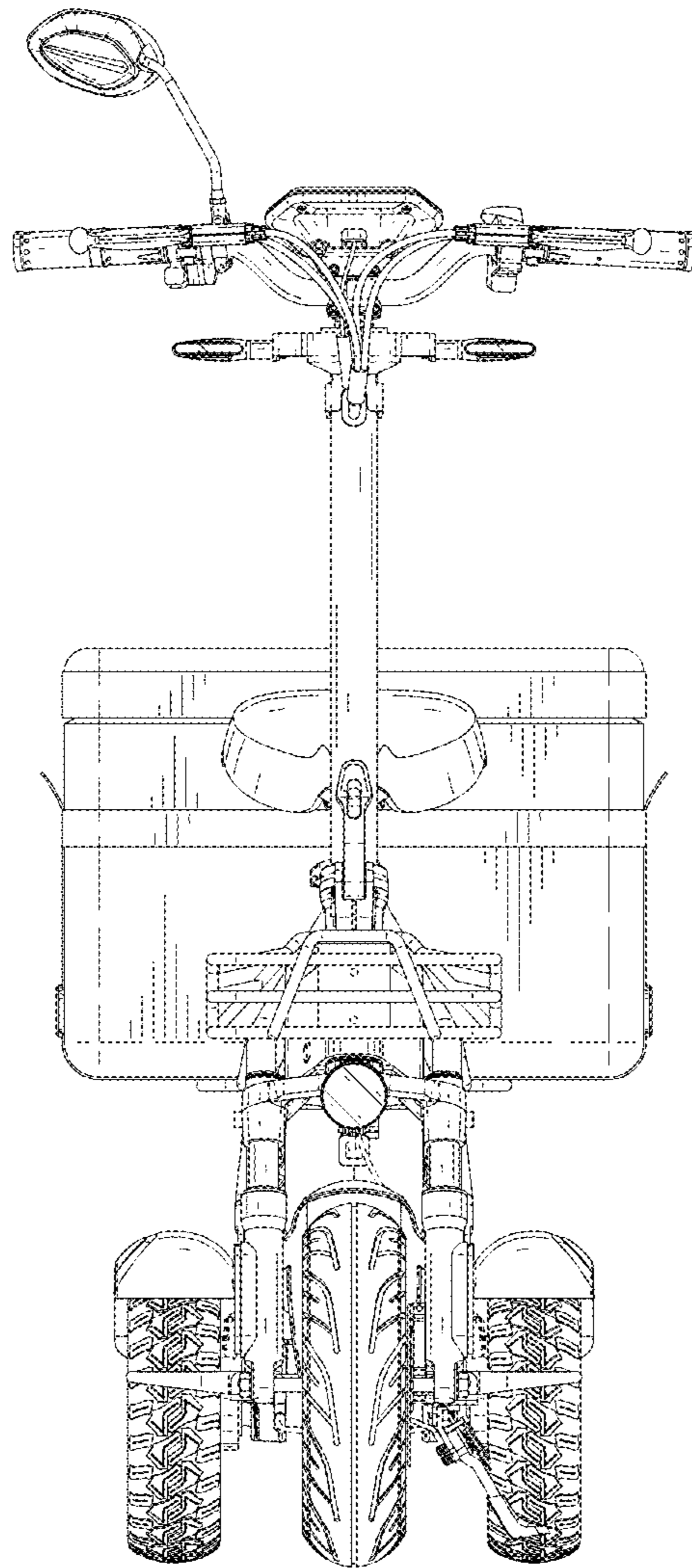

FIG. 5

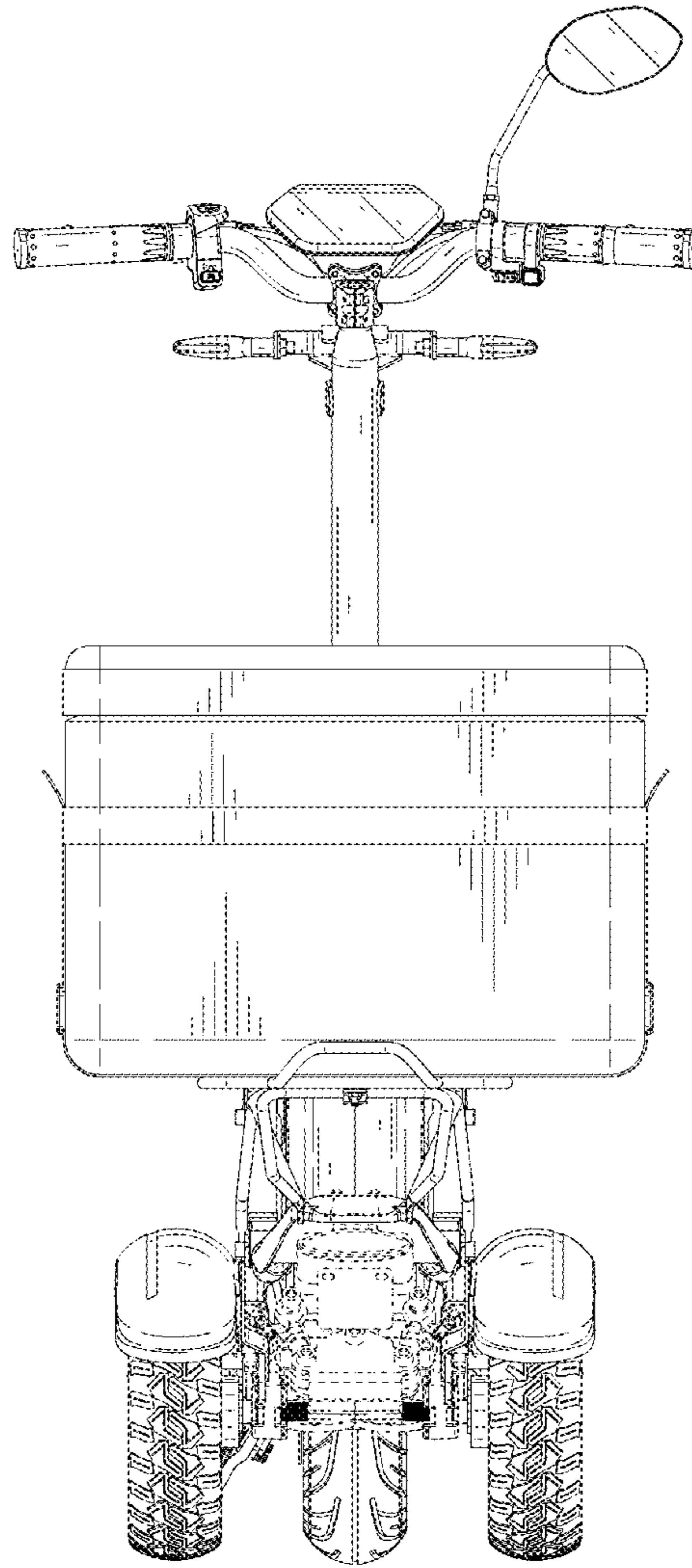

FIG. 6

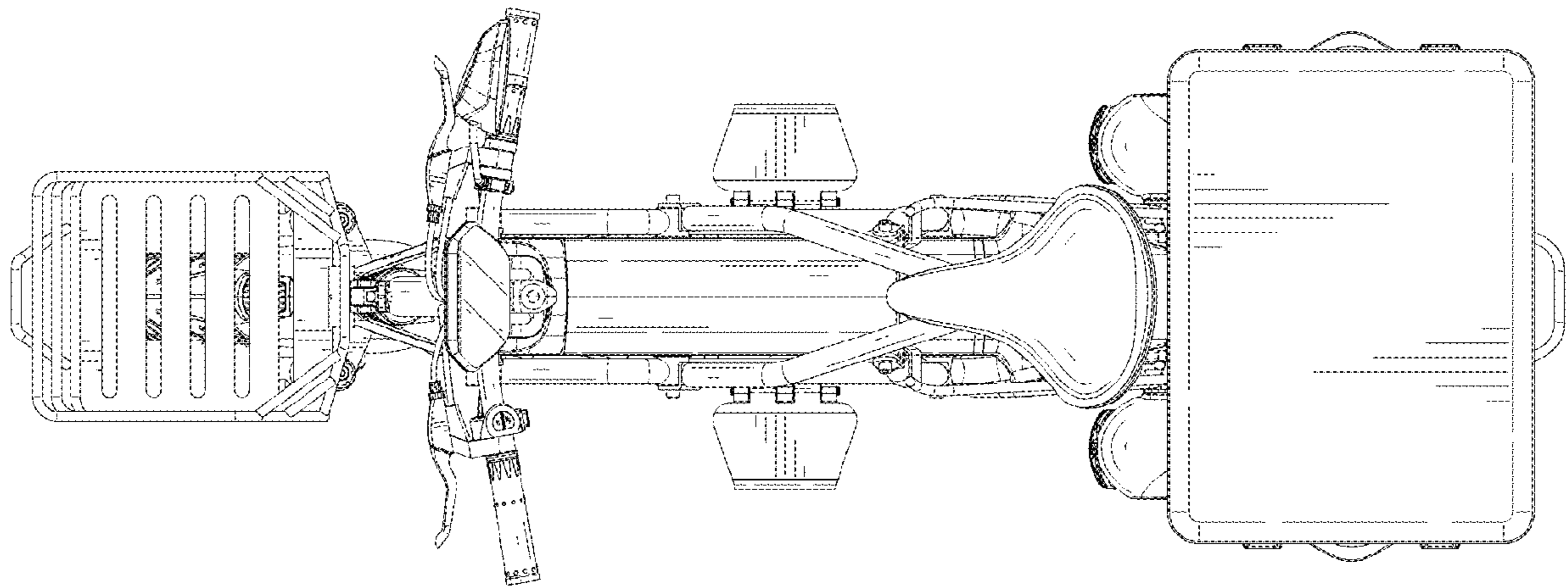

FIG. 7



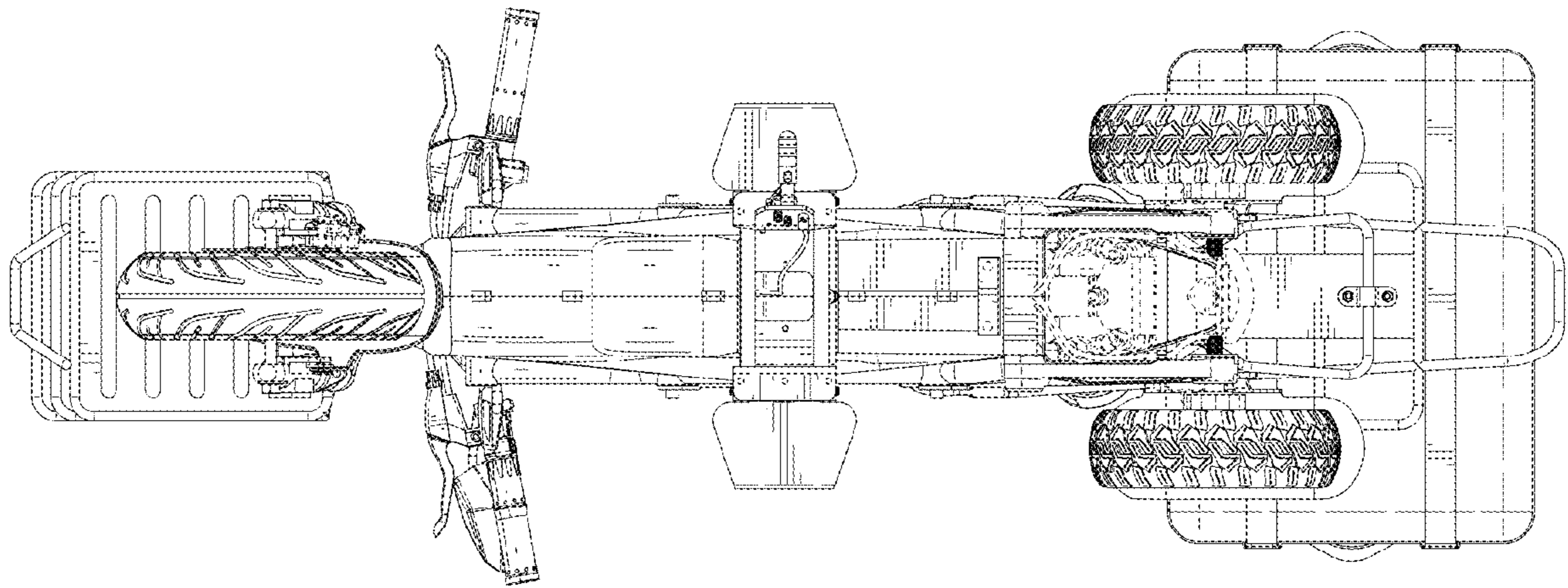

FIG. 8

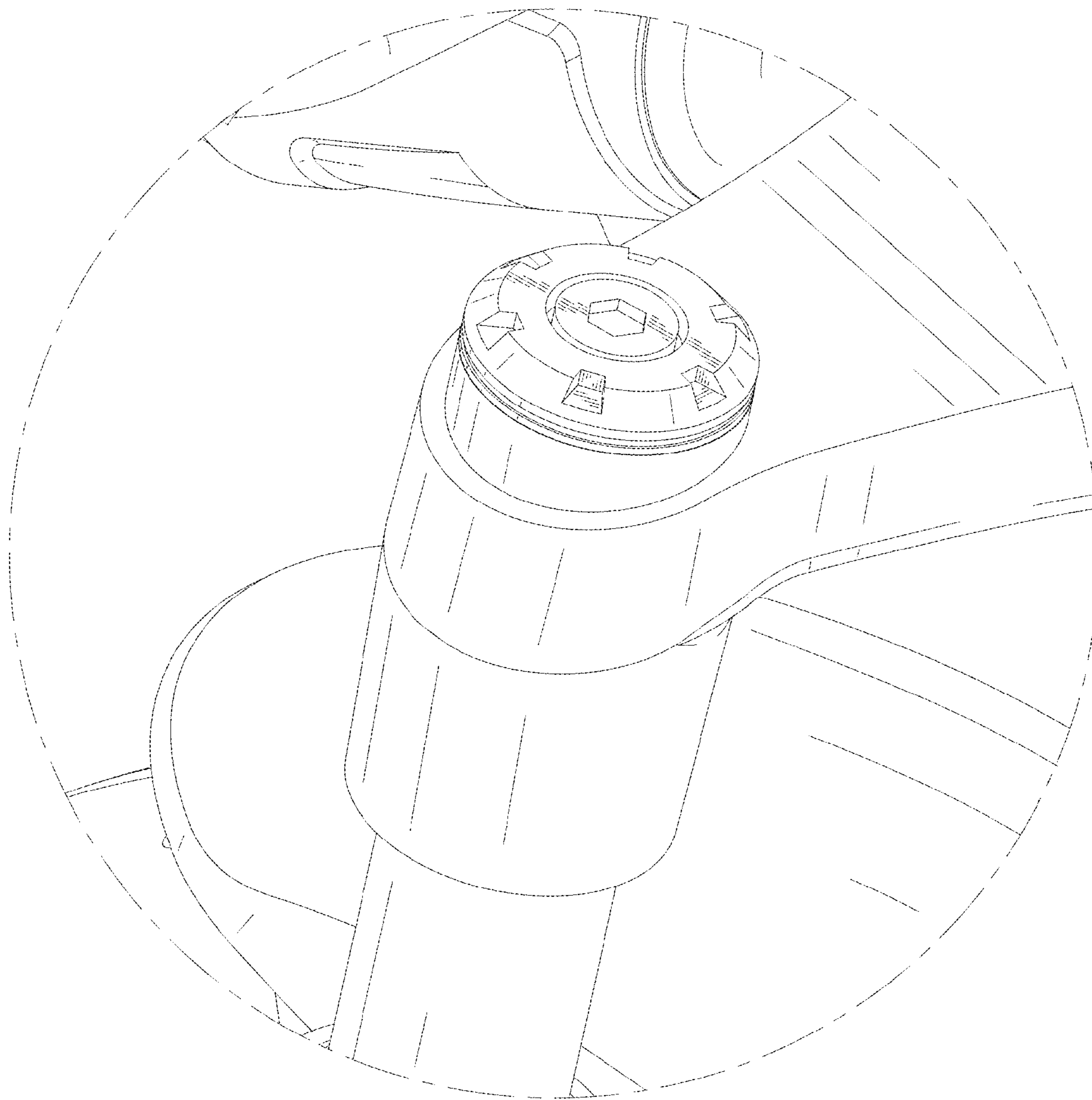

FIG. 9