



US00D982428S

(12) **United States Design Patent** (10) **Patent No.:** **US D982,428 S**  
**Roach et al.** (45) **Date of Patent:** **\*\* Apr. 4, 2023**

(54) **MESH CLAMP**

FOREIGN PATENT DOCUMENTS

(71) Applicants: **SANDVIK MINING AND CONSTRUCTION AUSTRALIA PTY LTD**, Milton (AU); **Sandvik Mining and Construction Tools AB**, Sandviken (SE)

CN 112324481 A \* 2/2021  
CN 110640650 B \* 3/2021 ..... B25B 11/00  
WO WO-2019151908 A1 \* 8/2019 ..... E21D 11/383

(72) Inventors: **Warren Roach**, Durren Durren (AU); **Peter Young**, Bray Park (AU); **Mietek Rataj**, Charlestown (AU); **Bradley Darlington**, Wellard (AU)

OTHER PUBLICATIONS

Electric Mesh Clamp, website 2022, site visited Nov. 4, 2022, [https://www.elesa-ganter.com/en/www/products/levelling-elements--1/bearing-end-caps--1/Levelling-elements--Support-clamp-for-panels-and-electro-welded-mesh--PPR.\\*](https://www.elesa-ganter.com/en/www/products/levelling-elements--1/bearing-end-caps--1/Levelling-elements--Support-clamp-for-panels-and-electro-welded-mesh--PPR.*)

(73) Assignee: **Sandvik Mining and Construction Australia Pty Ltd.**, Milton (AU)

*Primary Examiner* — John R Yeh

(74) *Attorney, Agent, or Firm* — Banner & Witcoff, Ltd.

(\*\*) Term: **15 Years**

(21) Appl. No.: **29/774,720**

(57) **CLAIM**

(22) Filed: **Mar. 18, 2021**

The ornamental design for a mesh clamp, as shown and described.

**Related U.S. Application Data**

**DESCRIPTION**

(62) Division of application No. 29/671,392, filed on Nov. 27, 2018, now Pat. No. Des. 949,676.

(51) **LOC (14) Cl.** ..... **08-08**

(52) **U.S. Cl.**  
USPC ..... **D8/394**

(58) **Field of Classification Search**  
USPC ..... D8/394-396; D3/215, 247; D20/22, 28; D19/10; D23/262  
CPC . A45F 5/02; A45F 5/021; A45F 5/004; A44C 3/001; A61B 46/23; B65D 63/1027; F16L 3/127; F16L 3/12  
See application file for complete search history.

FIG. 1 is a top plan view of a mesh clamp showing our new design;  
FIG. 2 is a right side view thereof;  
FIG. 3 is a front view thereof;  
FIG. 4 is a left side view thereof;  
FIG. 5 is a bottom view thereof;  
FIG. 6 is a perspective front view thereof;  
FIG. 7 is a perspective rear view thereof;  
FIG. 8 is a rear view thereof;  
FIG. 9 is a top plan view of the mesh clamp of FIGS. 1-8 without shading showing our new design thereof;  
FIG. 10 is a right side view thereof;  
FIG. 11 is a front view thereof;  
FIG. 12 is a left side view thereof;  
FIG. 13 is a bottom view thereof;  
FIG. 14 is a perspective front view thereof;  
FIG. 15 is a perspective rear view thereof; and,  
FIG. 16 is a rear view thereof.

(56) **References Cited**

U.S. PATENT DOCUMENTS

4,084,068 A \* 4/1978 Lepik ..... H05K 7/12  
174/138 R  
4,290,338 A \* 9/1981 Gruber ..... E21D 21/0093  
411/21  
D322,557 S \* 12/1991 Cummings ..... D8/394

(Continued)

**1 Claim, 4 Drawing Sheets**

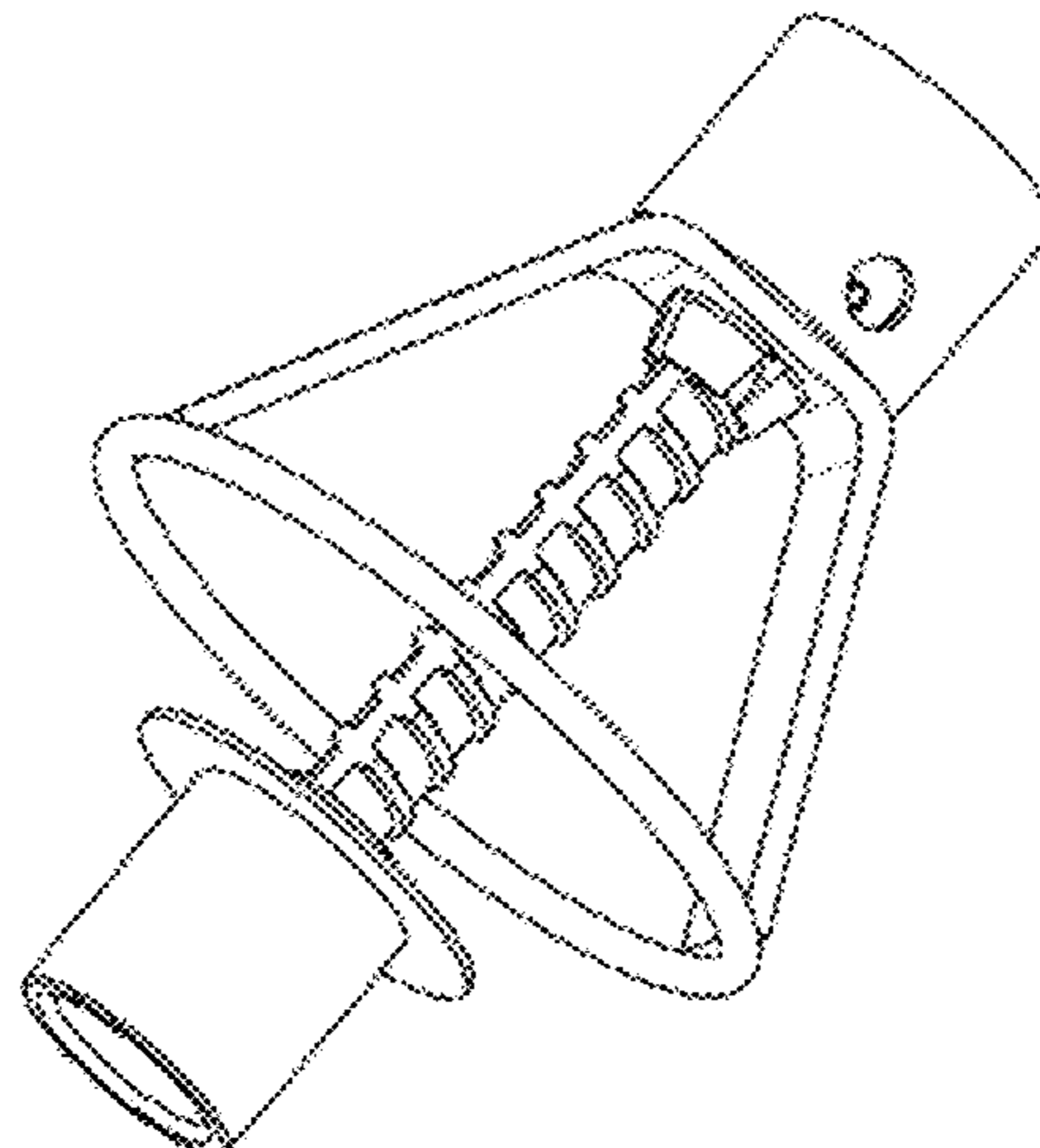
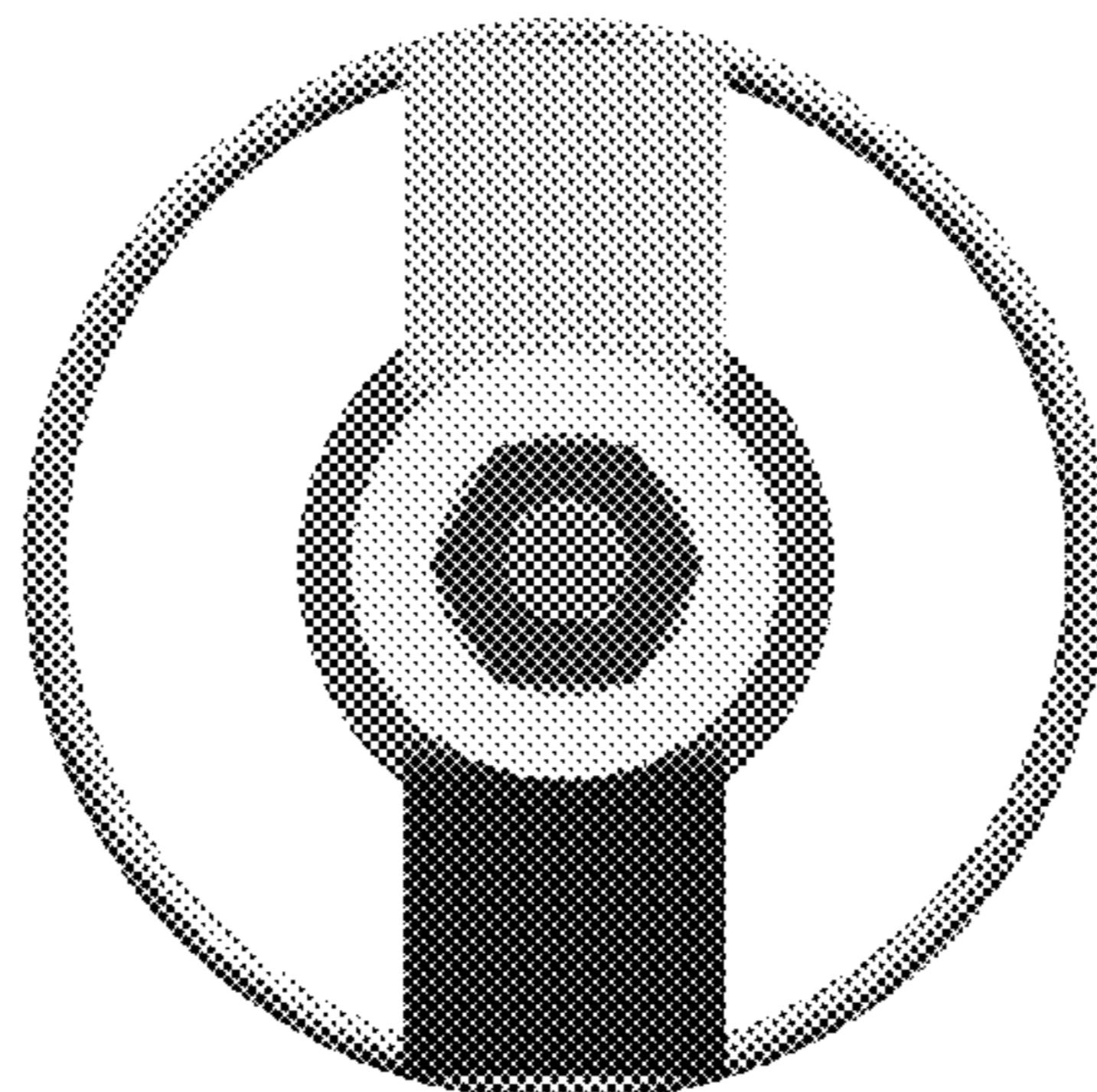

(56)

**References Cited**

U.S. PATENT DOCUMENTS

5,207,535	A *	5/1993	Saab .....	E21D 21/0086
				411/533
D346,954	S *	5/1994	Vandermast .....	D8/382
D373,070	S *	8/1996	Kriegstein .....	D8/354
D390,100	S *	2/1998	Thatcher .....	D8/394
6,183,182	B1 *	2/2001	Baumgartner .....	E04D 3/3603
				411/533
6,565,303	B1 *	5/2003	Riccitelli .....	F16B 43/00
				411/533
D563,156	S *	3/2008	Goodman .....	D7/387
8,336,275	B2 *	12/2012	Rodenhouse .....	E04F 13/045
				52/363
D682,073	S *	5/2013	Payne .....	D8/359
D795,061	S *	8/2017	Bacallao .....	D9/434
D818,808	S *	5/2018	Barnett .....	D8/394
D854,461	S *	7/2019	Haessly .....	D12/133
D862,453	S *	10/2019	Liang .....	D14/253
2020/0318479	A1 *	10/2020	Rataj .....	E21D 21/0026

\* cited by examiner

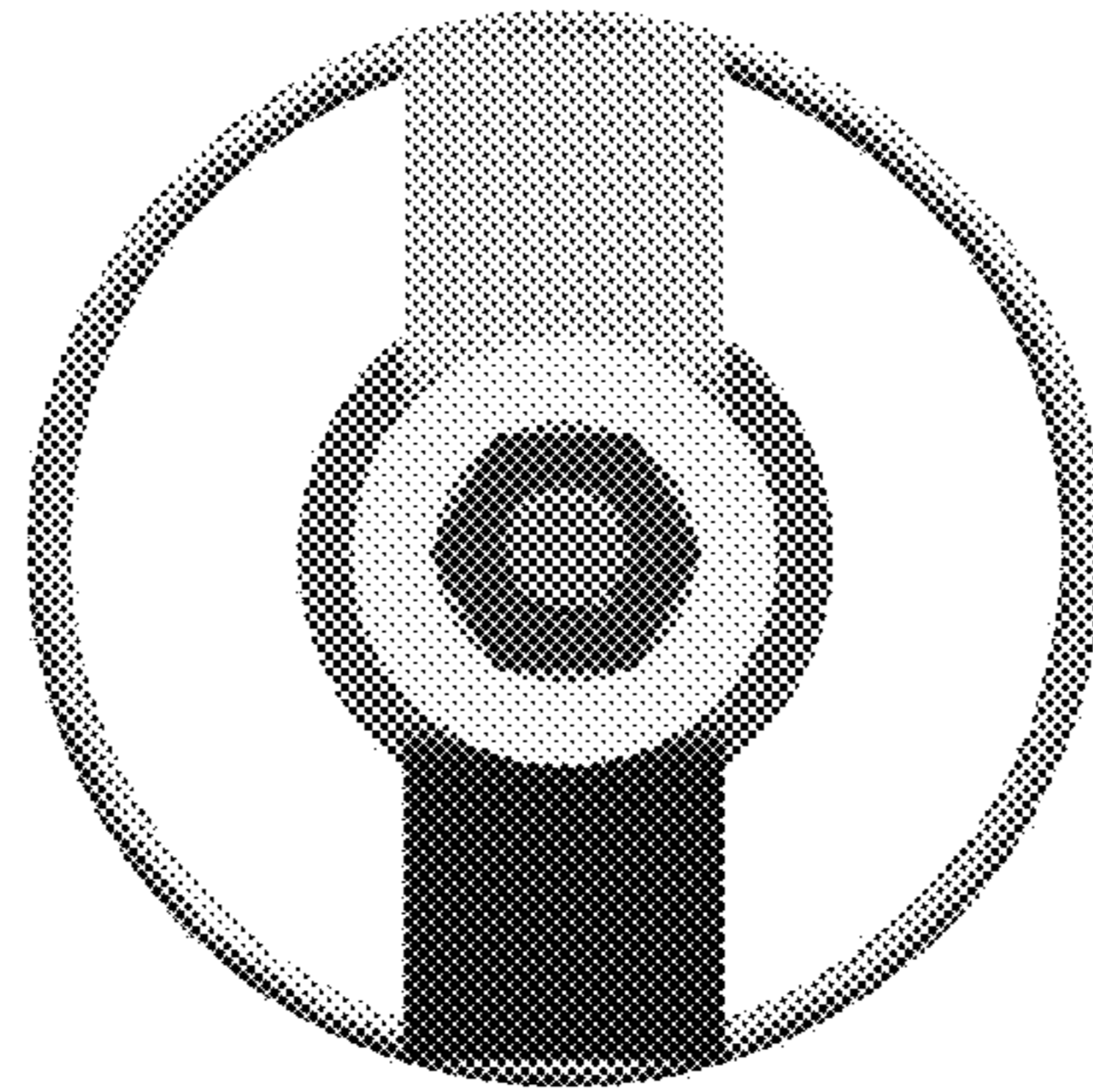

Fig. 1

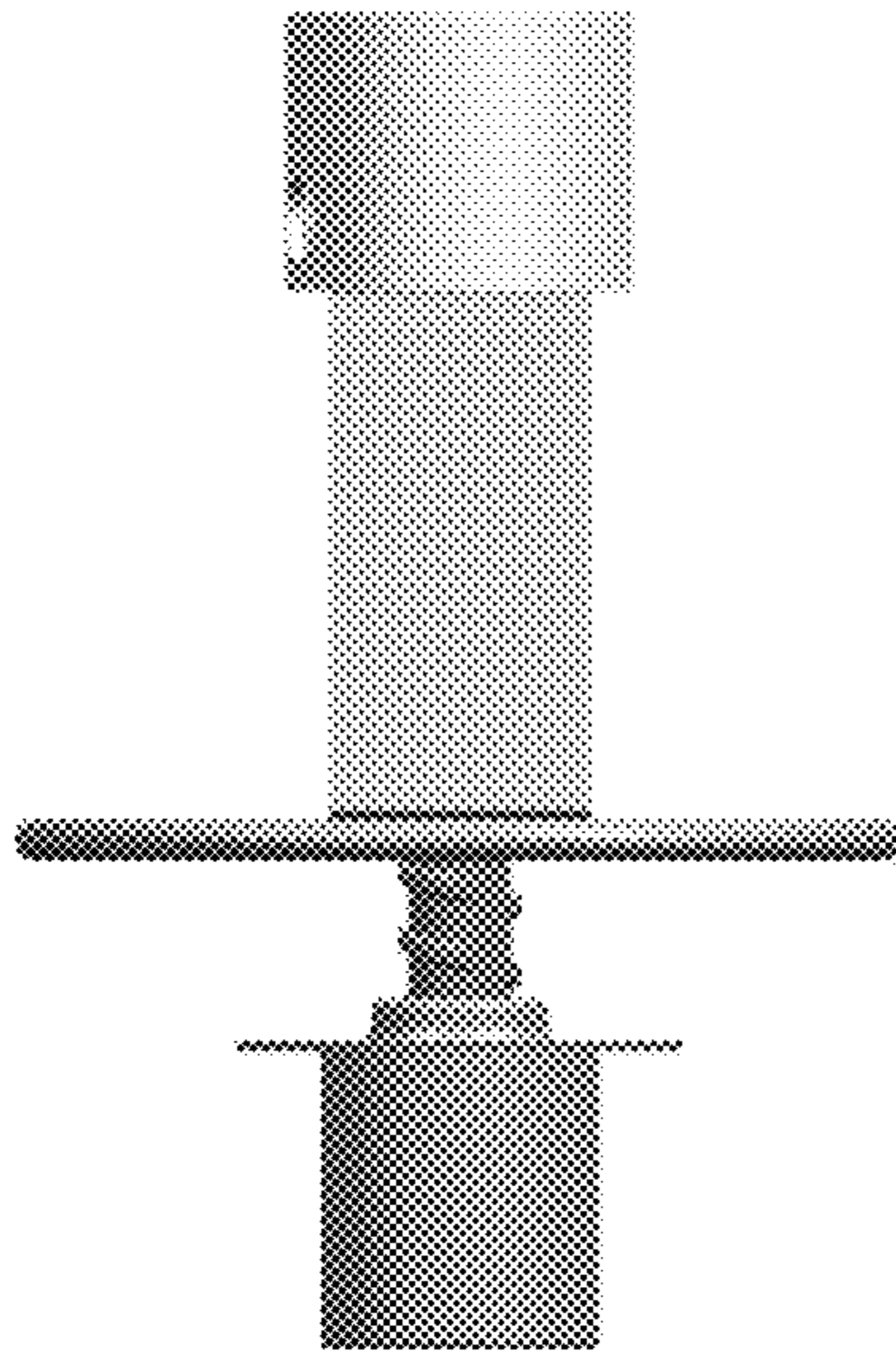

Fig. 2

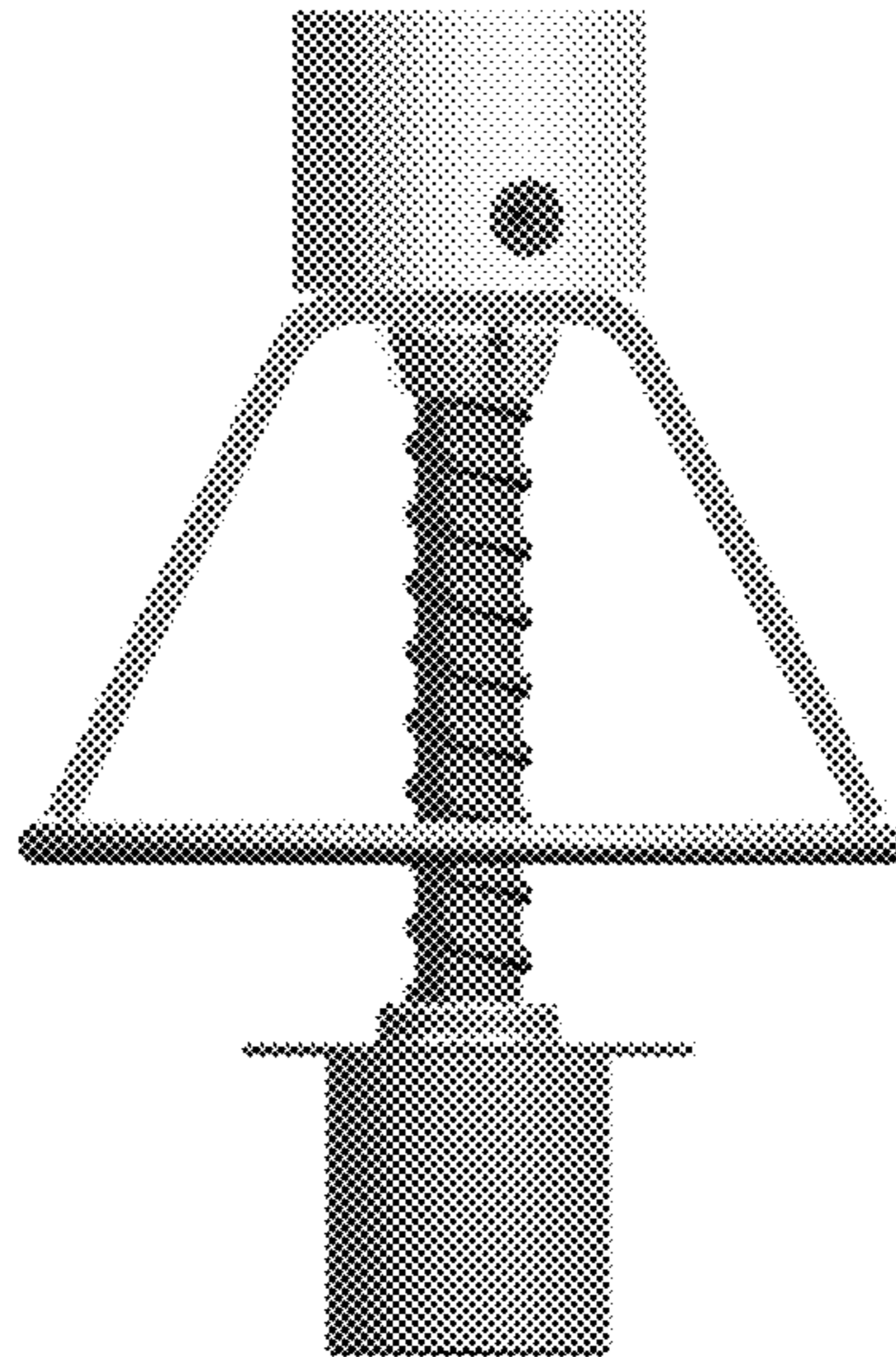

Fig. 3

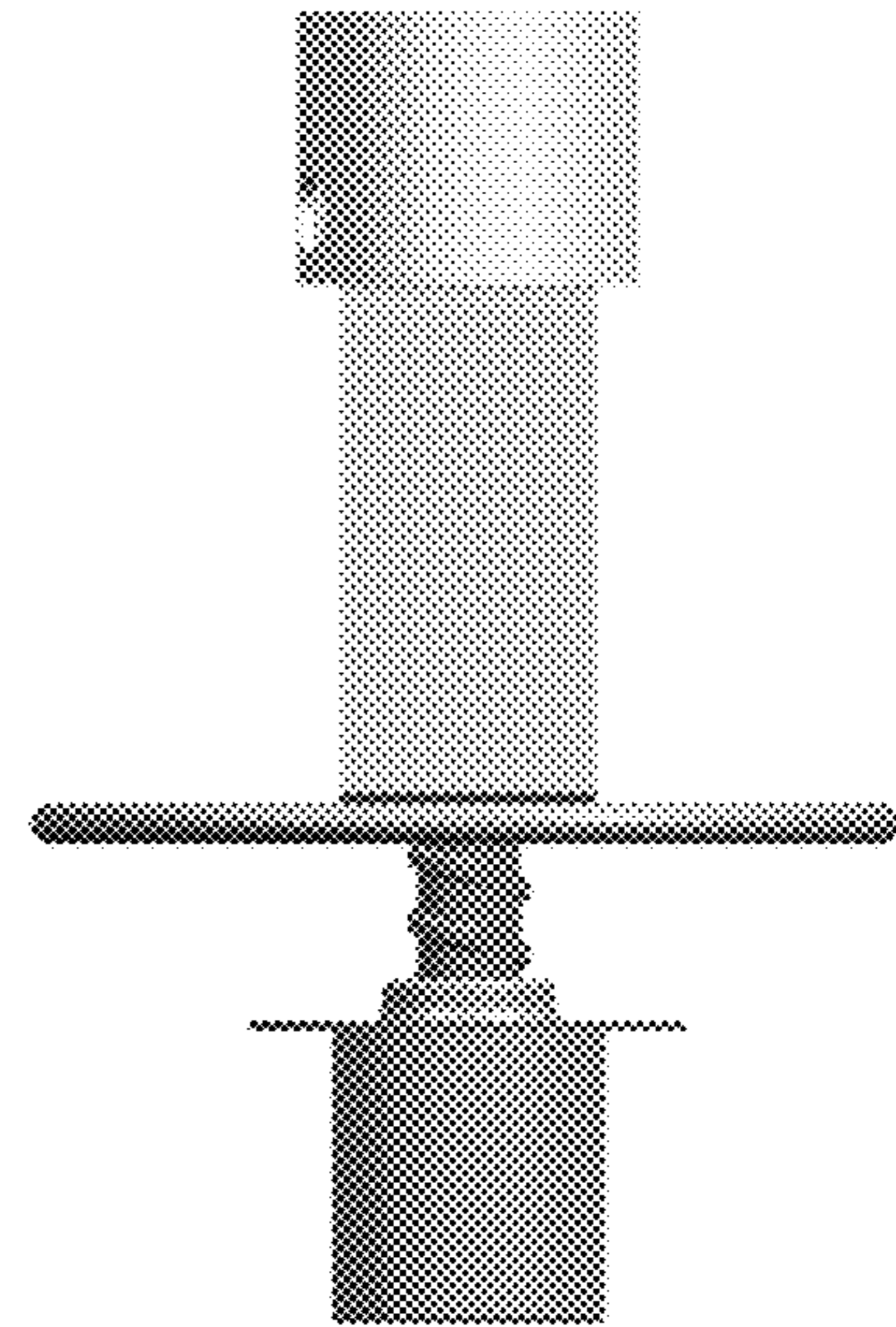

Fig. 4

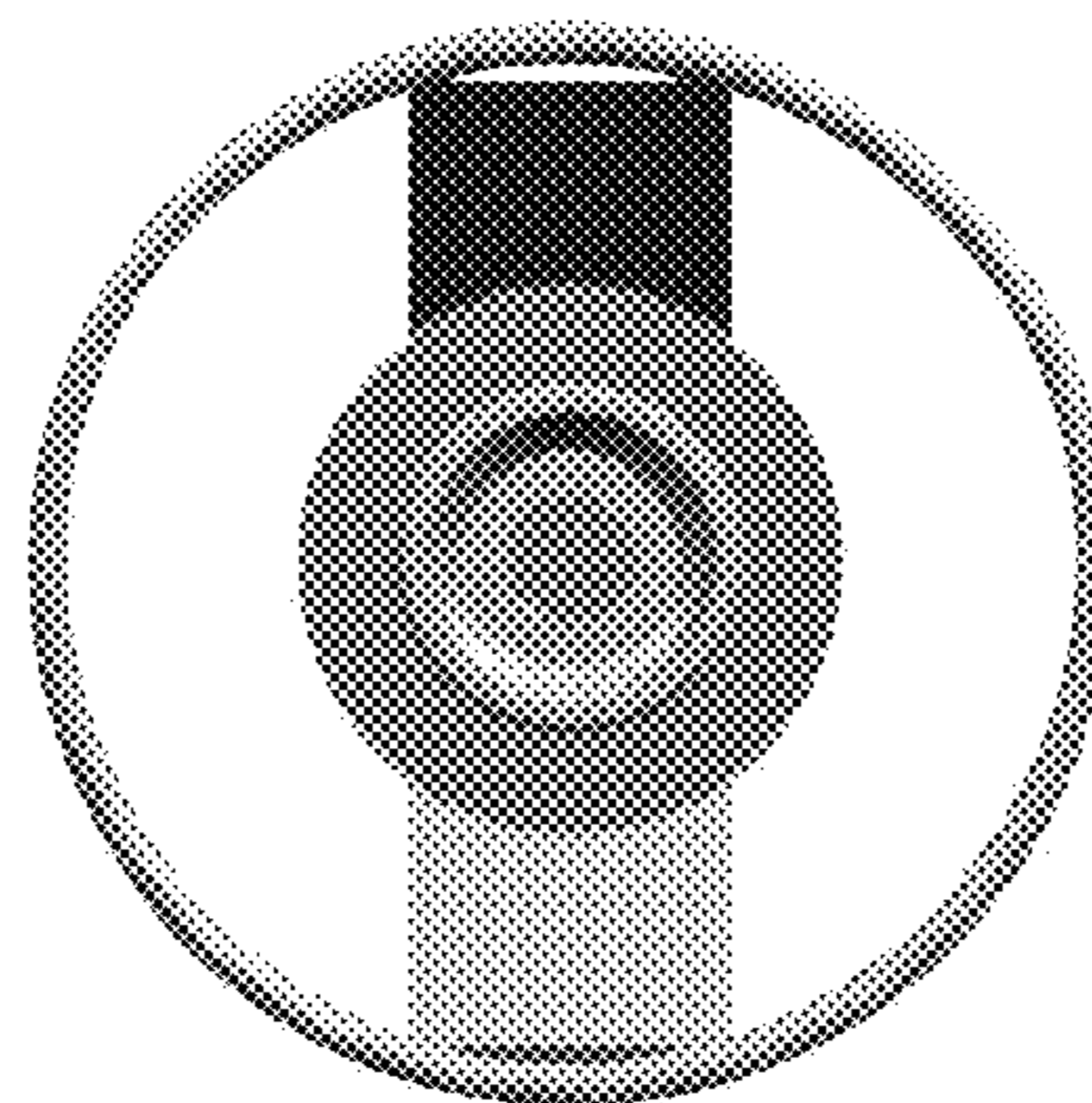

Fig. 5



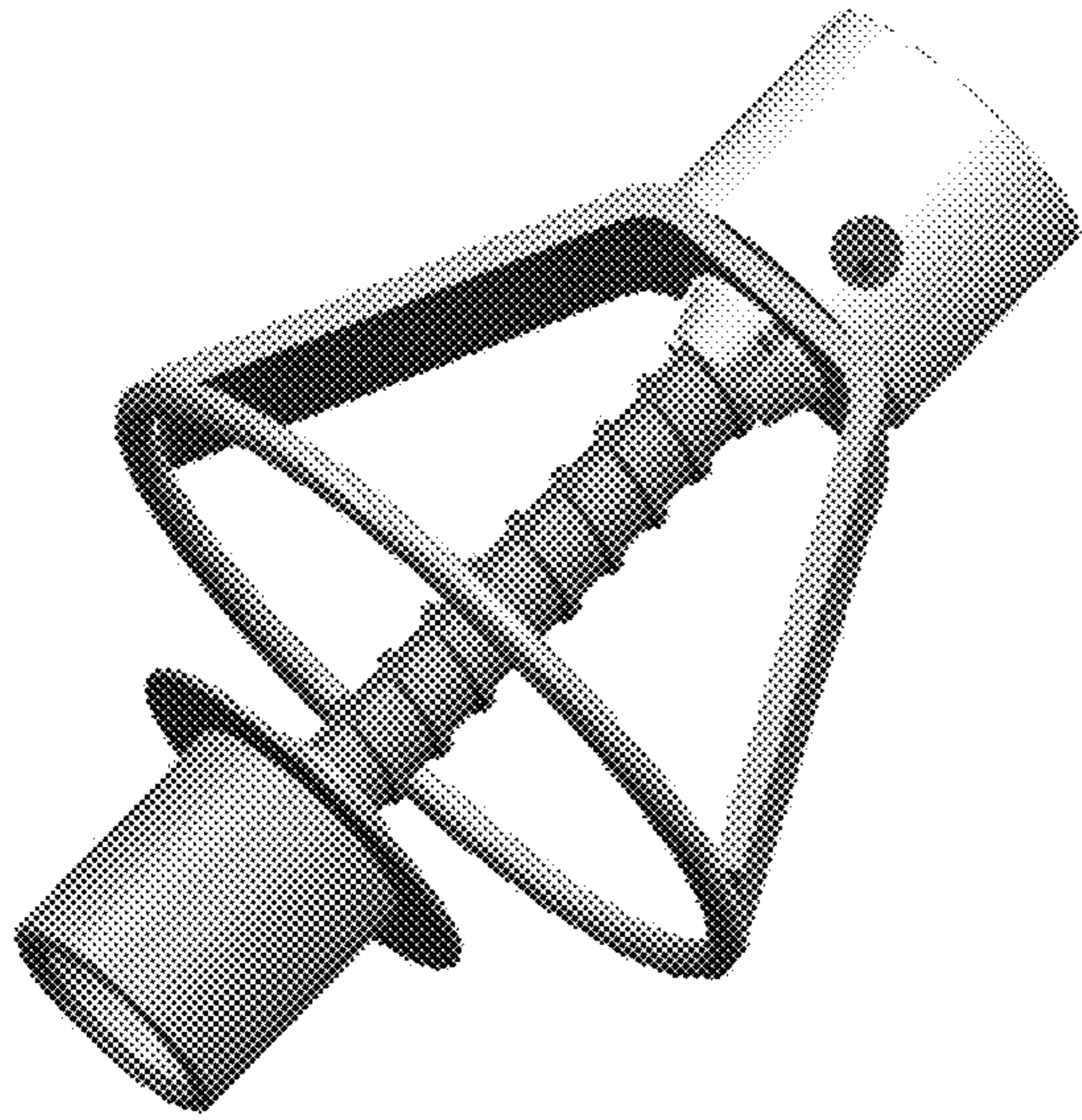

Fig. 6

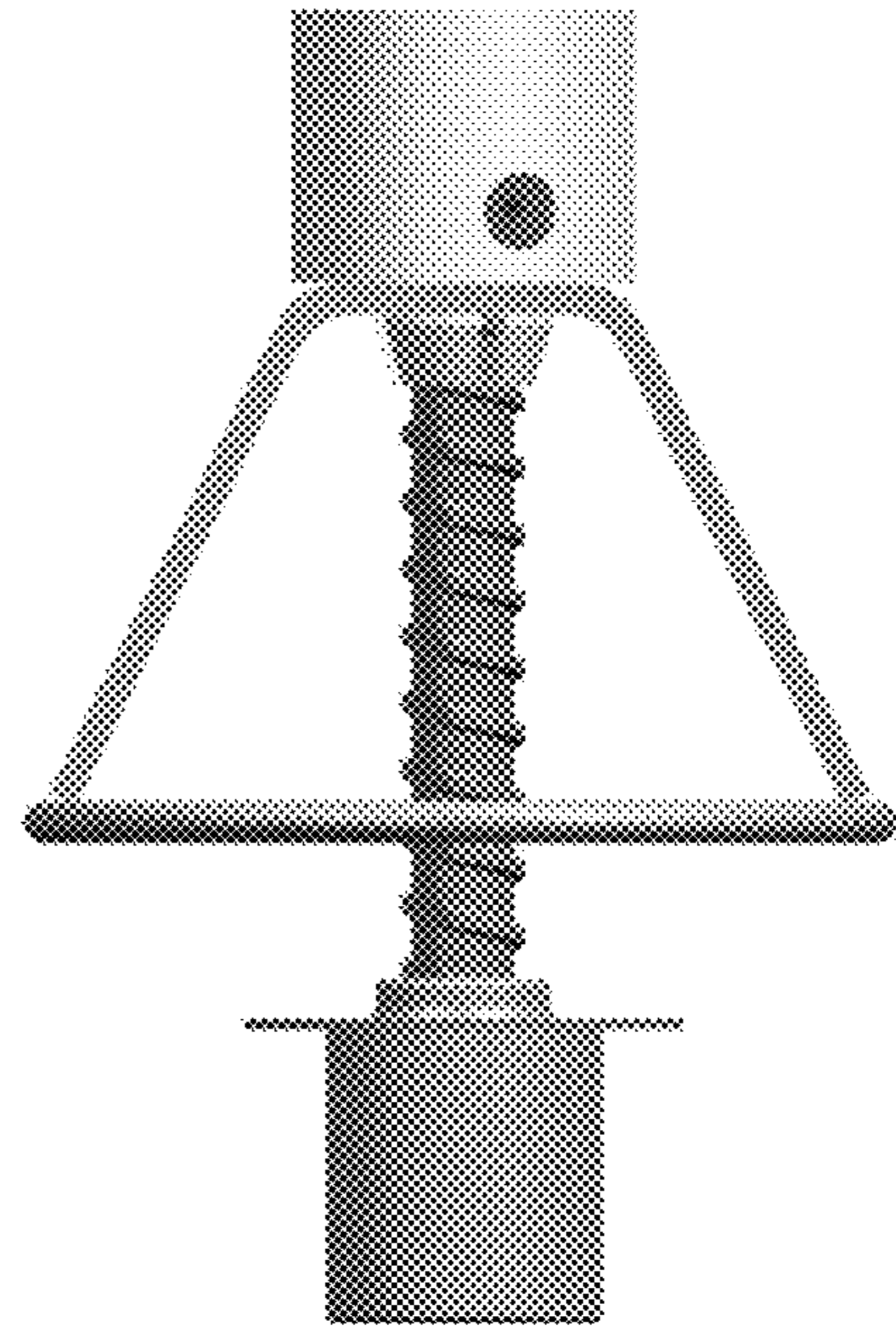

Fig. 8

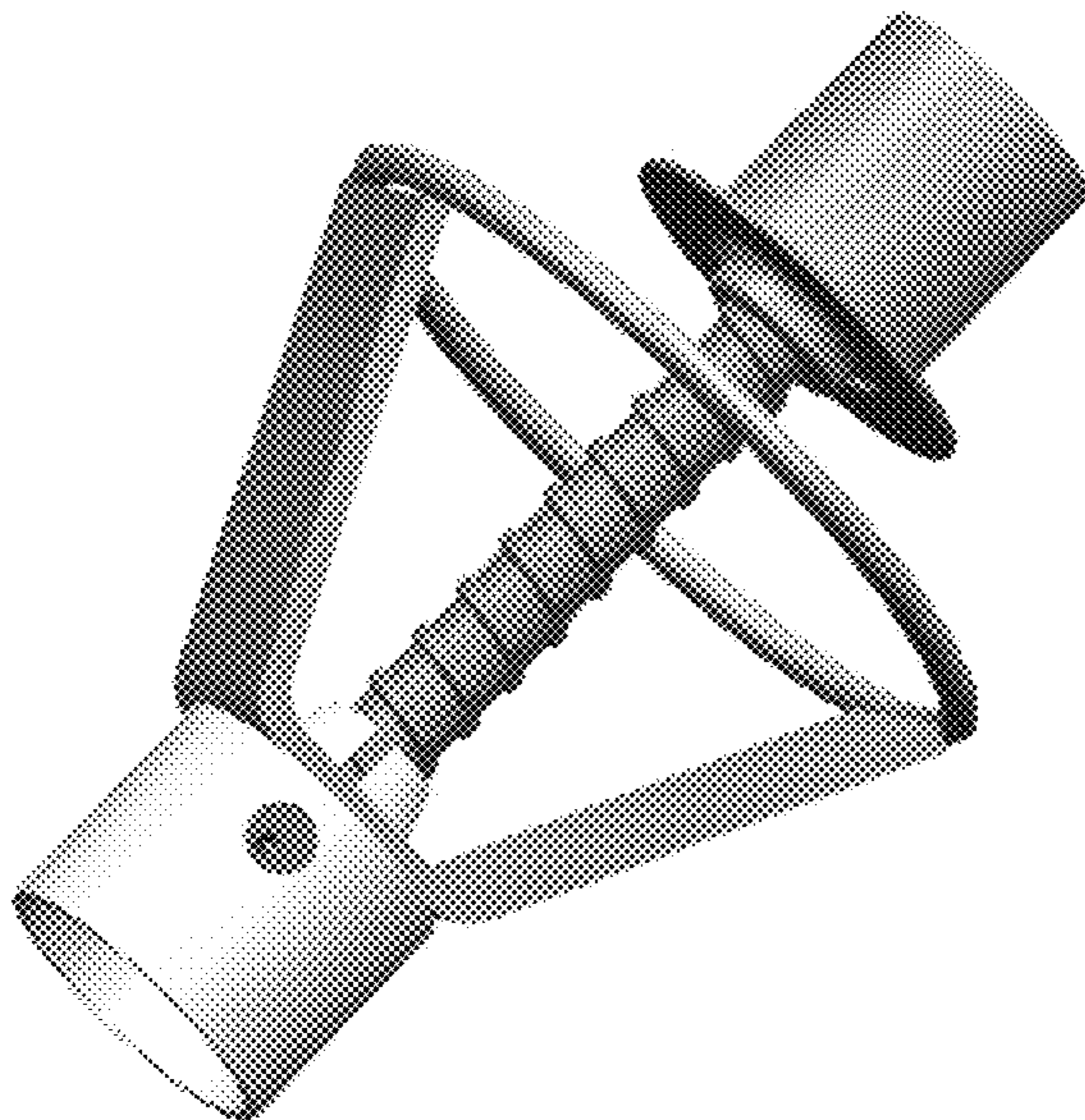

Fig. 7

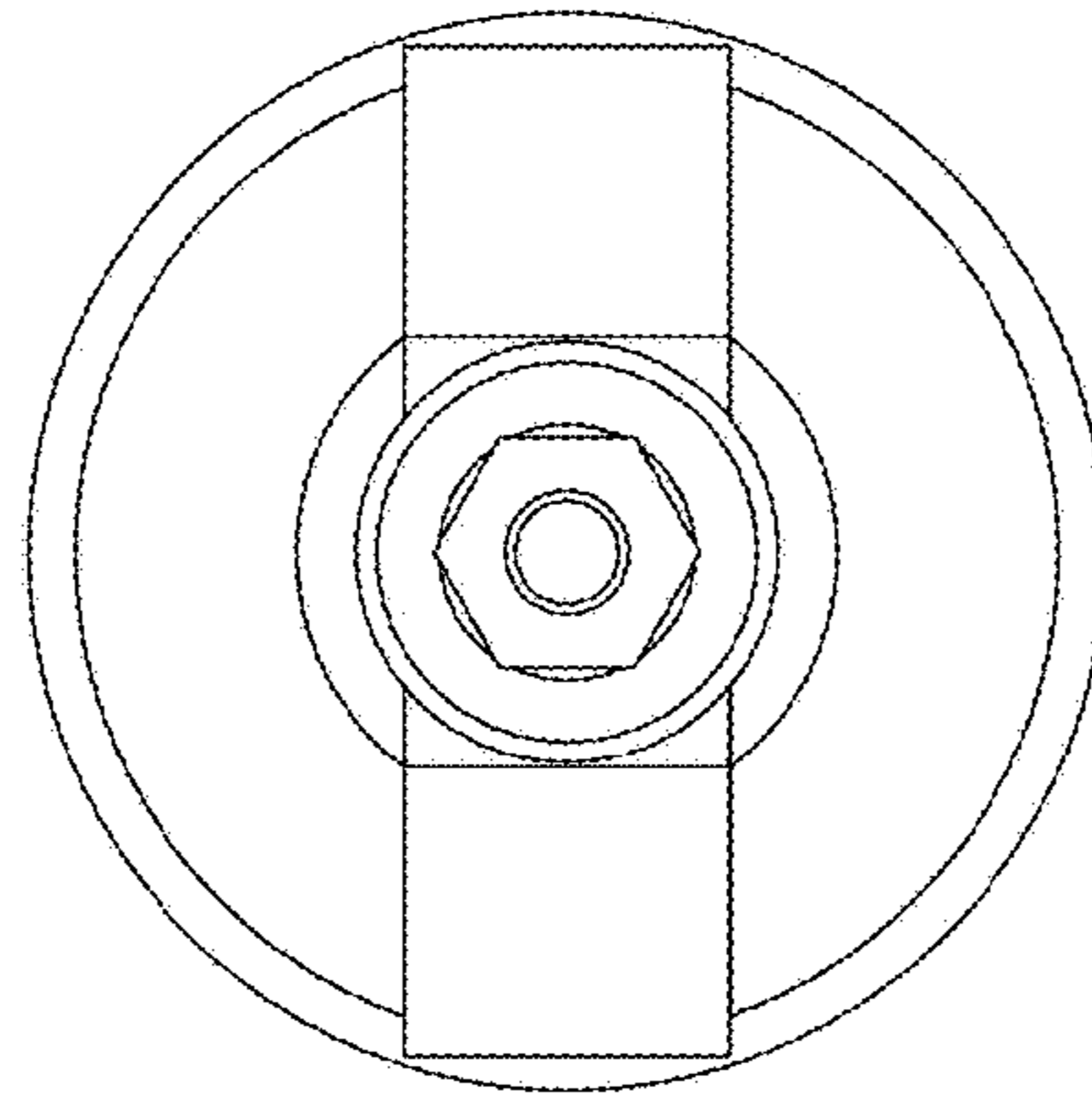

Fig. 9

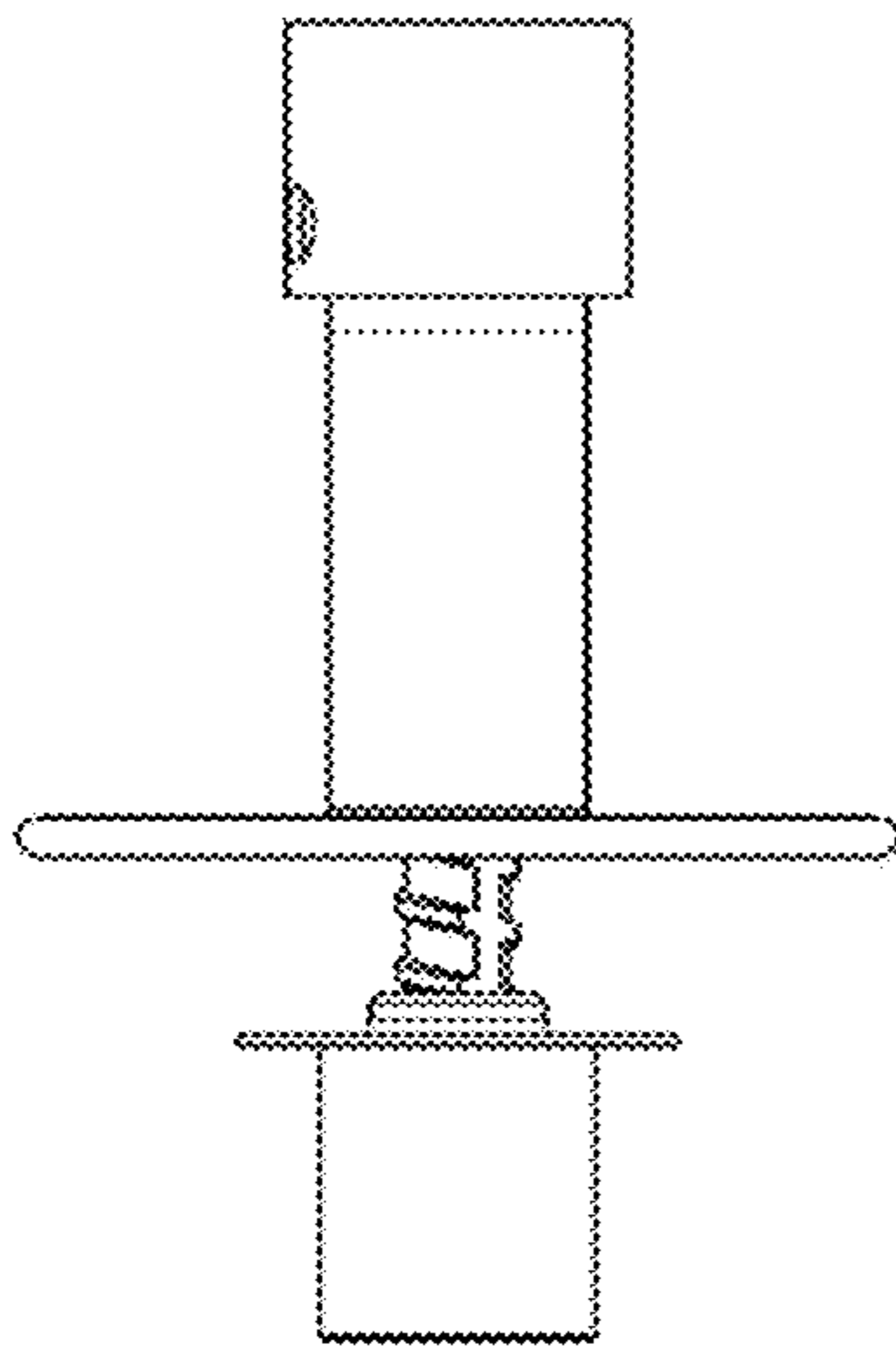

Fig. 10

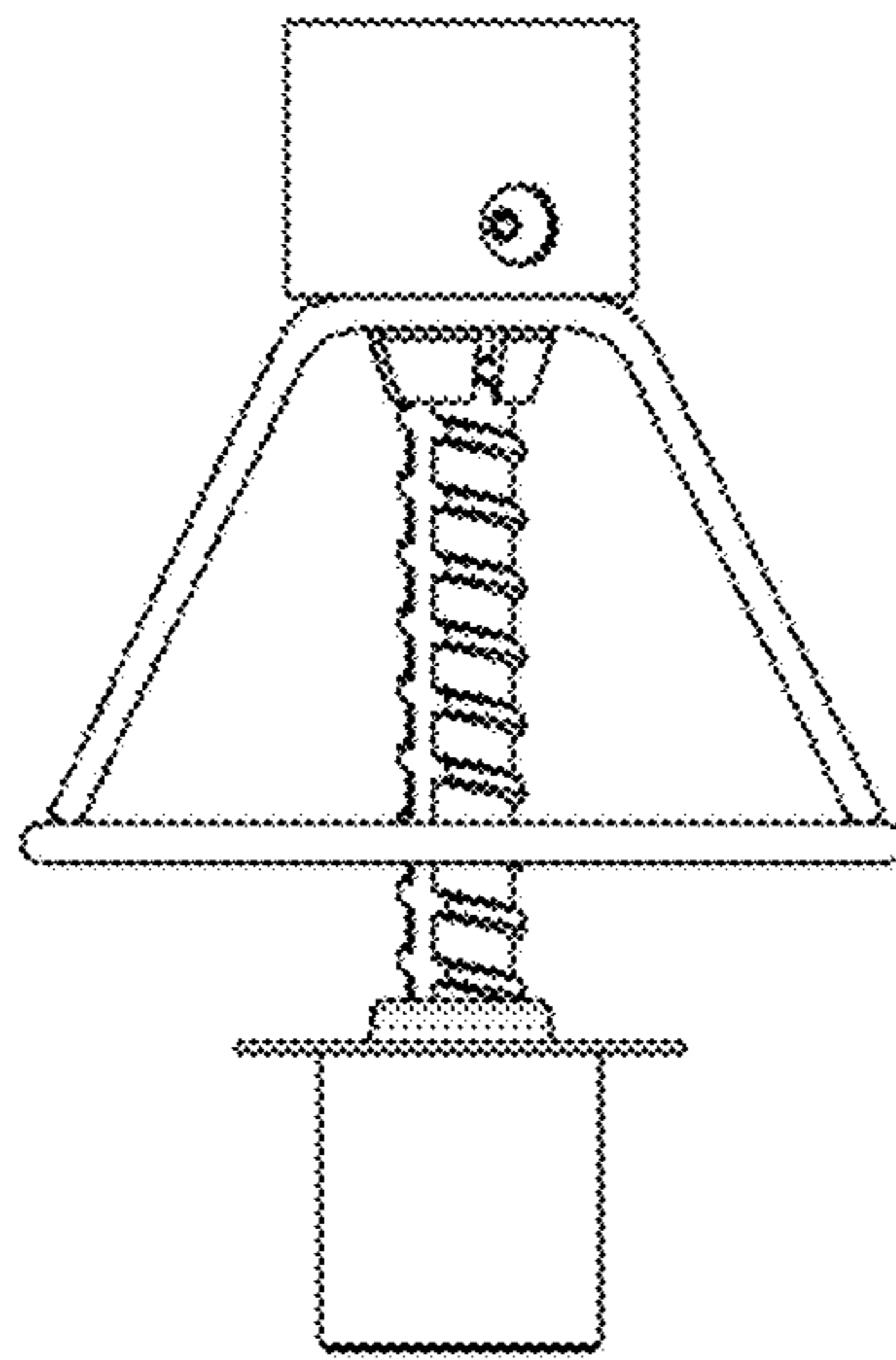

Fig. 11

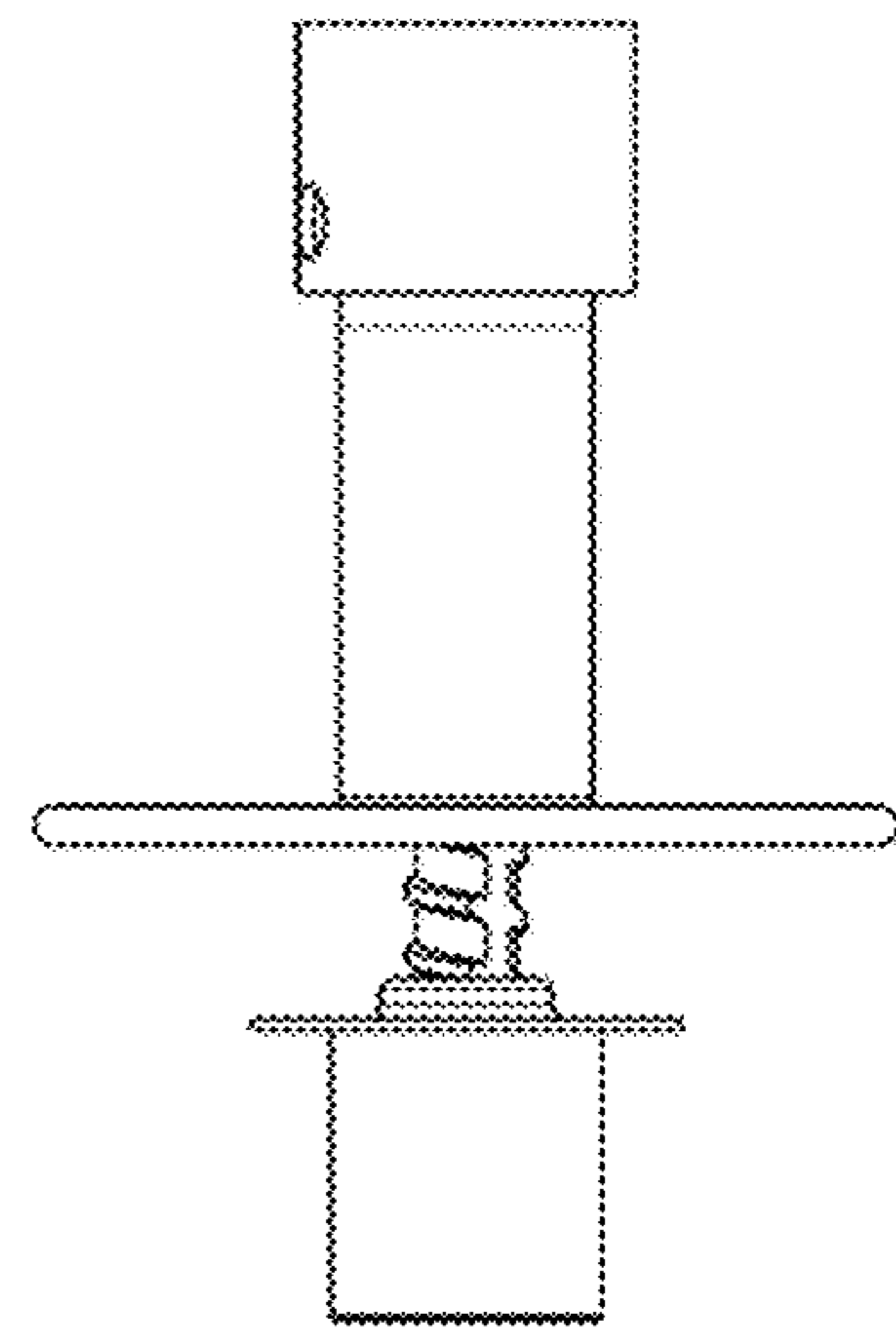

Fig. 12

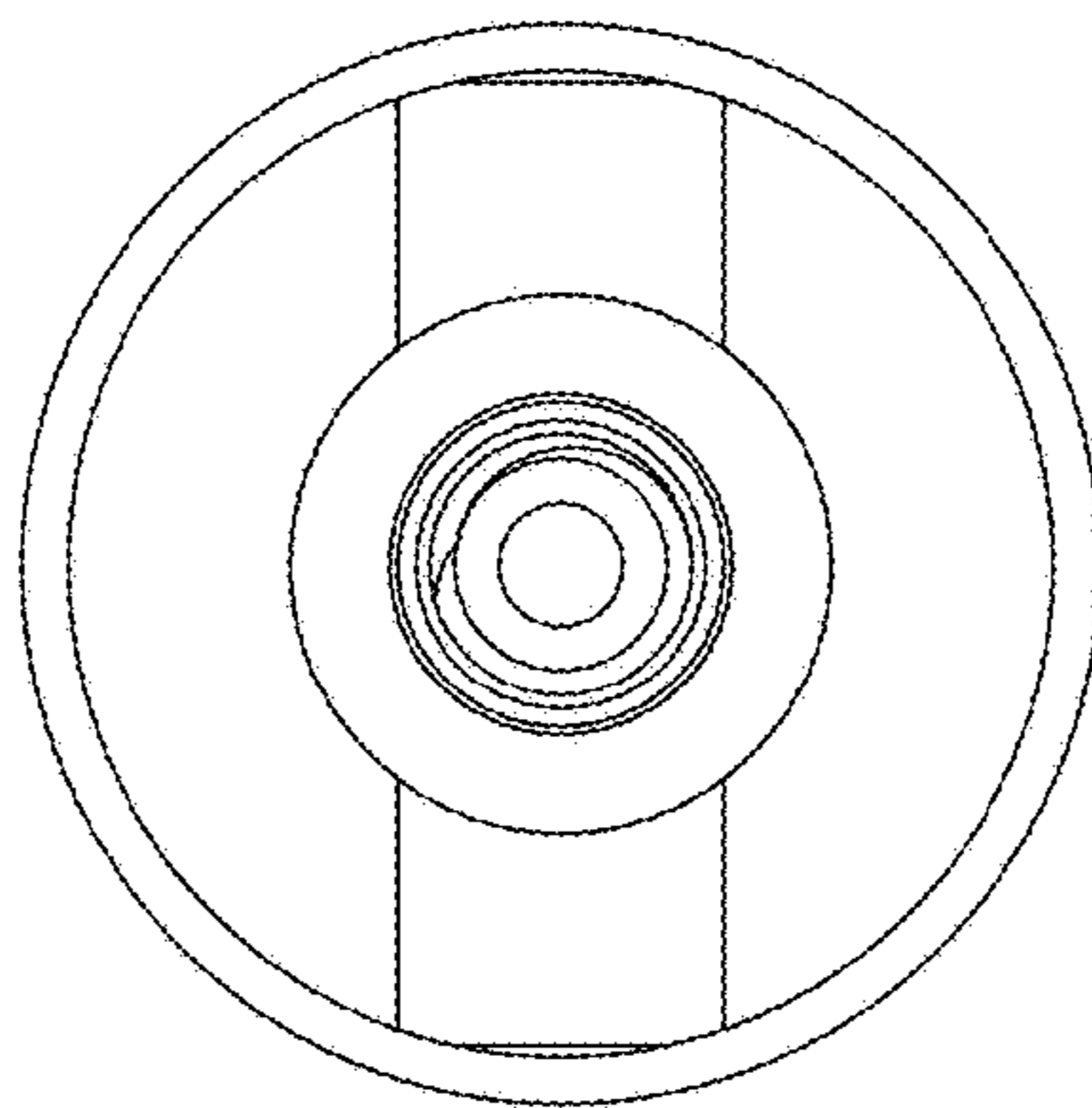

Fig. 13

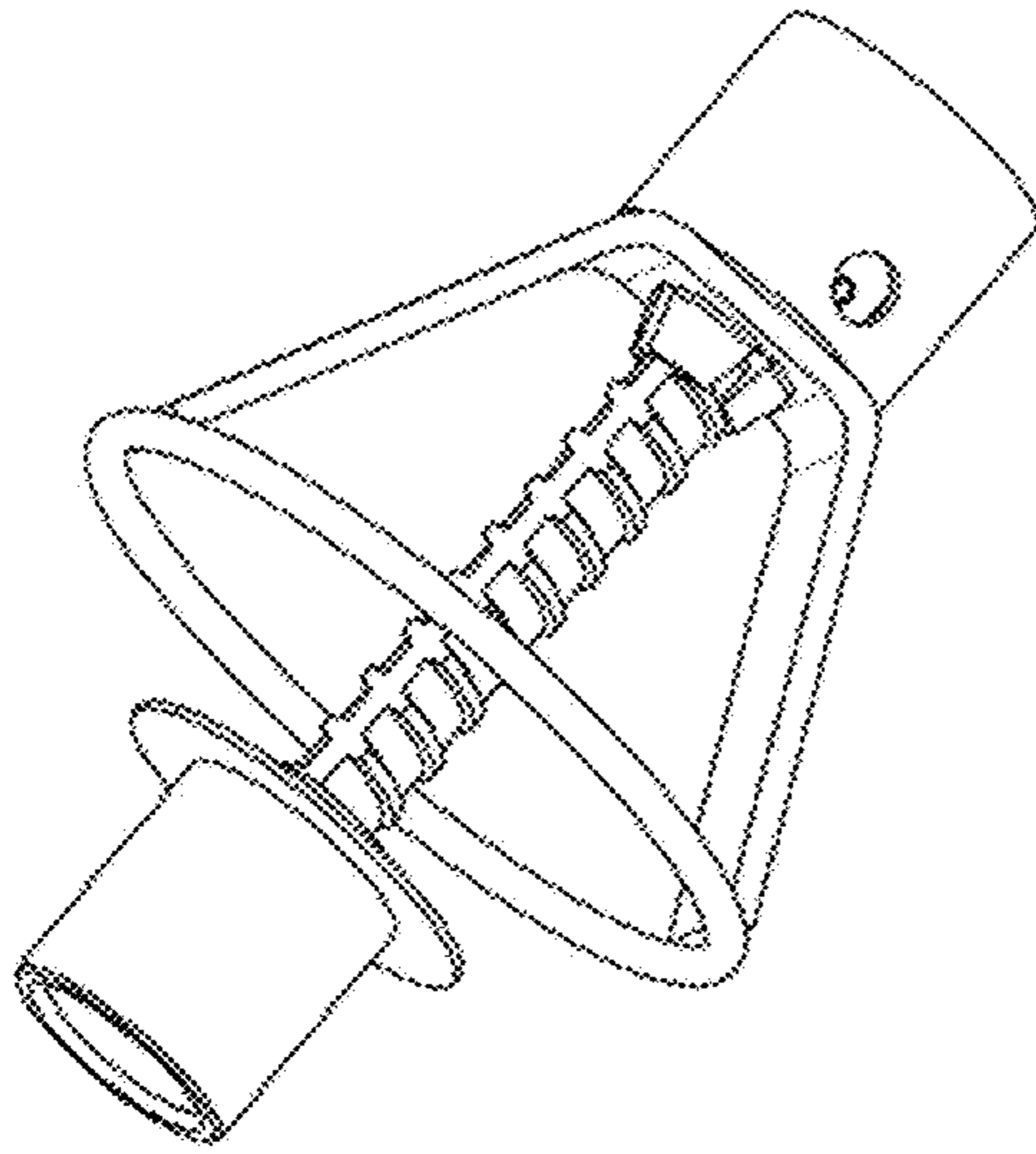

Fig. 14

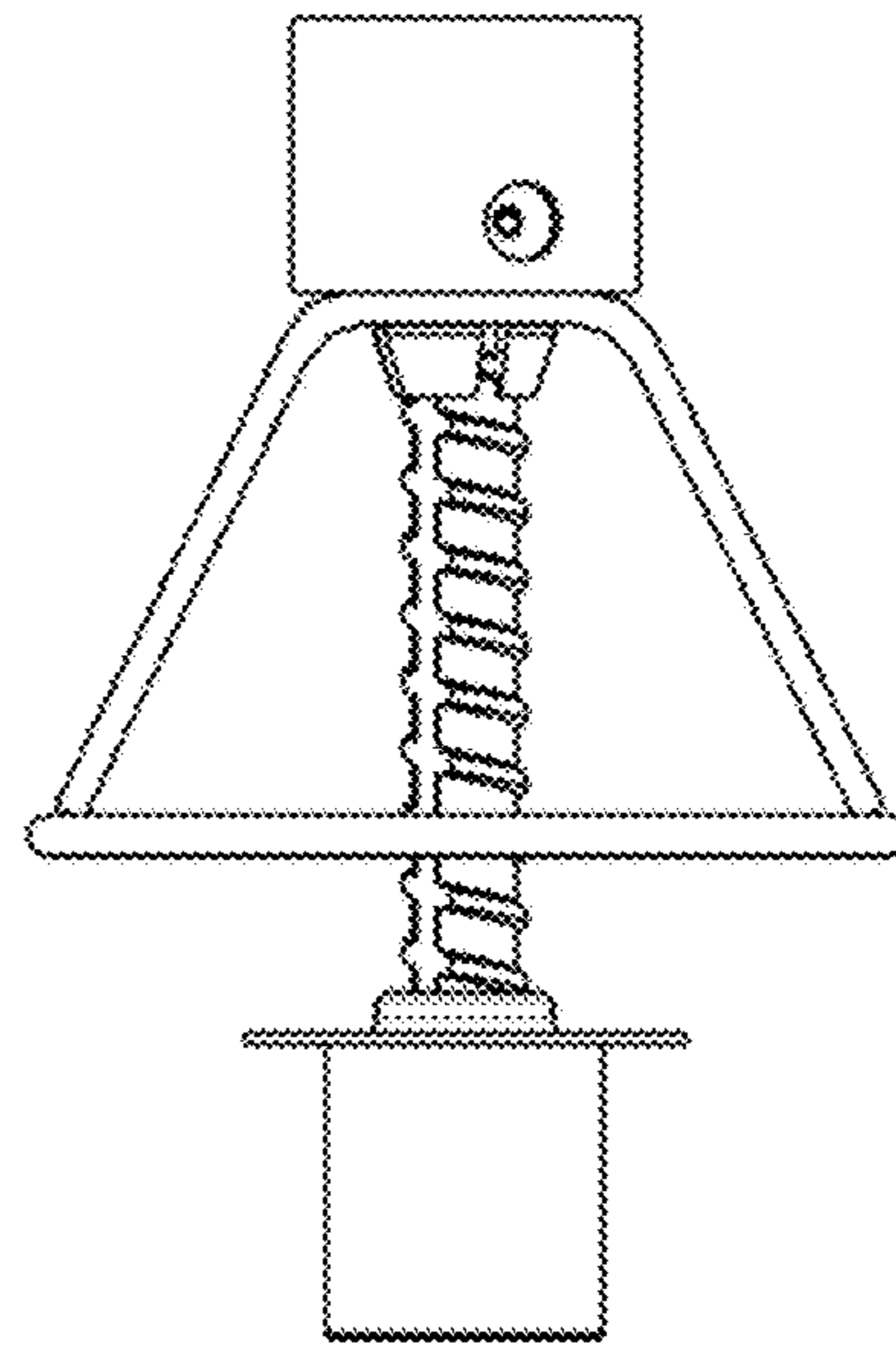

Fig. 16

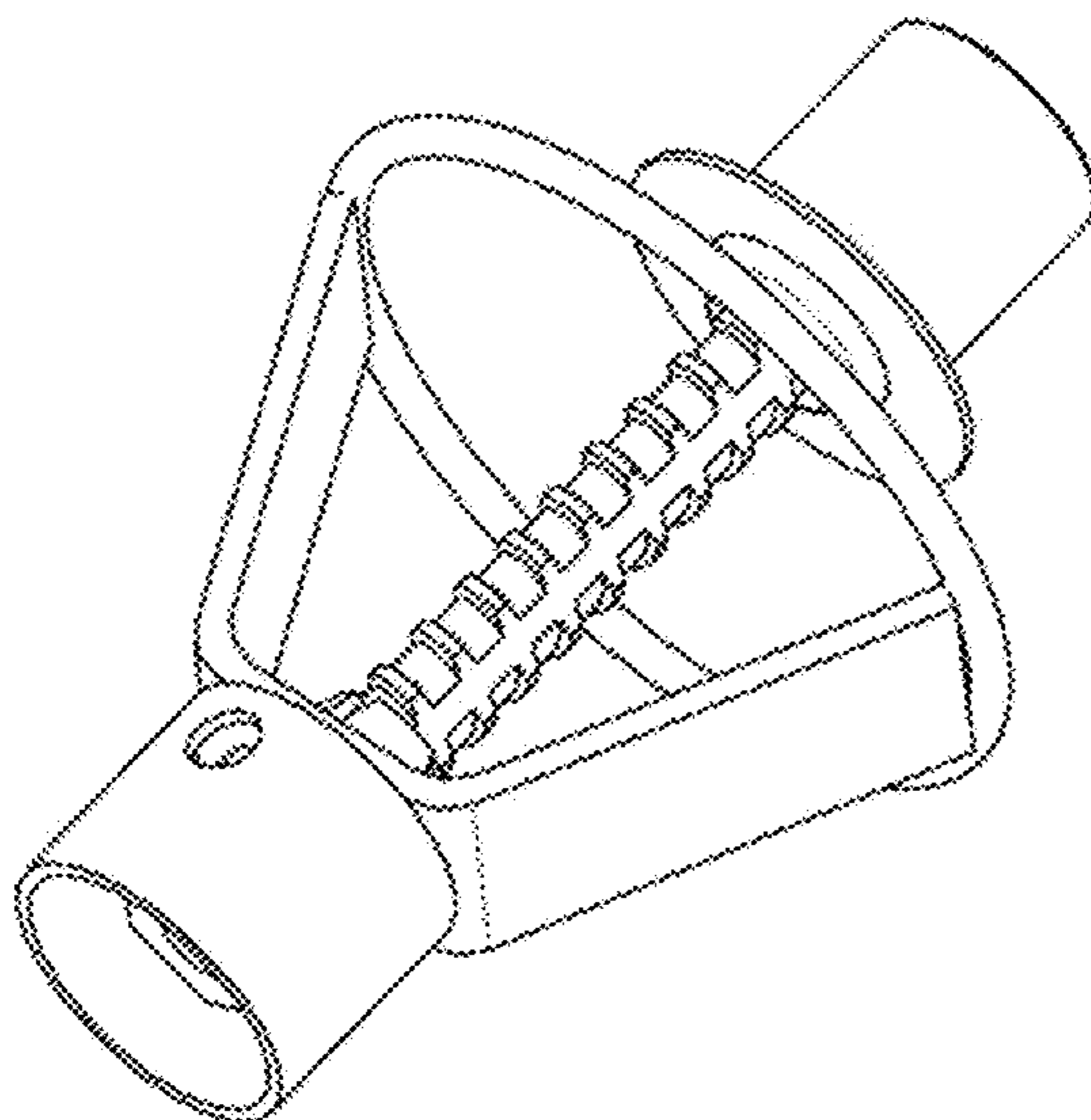

Fig. 15