



US00D982422S

(12) **United States Design Patent** (10) **Patent No.:** **US D982,422 S**
Olsen et al. (45) **Date of Patent:** **** Apr. 4, 2023**

(54) **HOOK ATTACHMENT**

(71) Applicant: **Bannack Medical LLC**, Gilbert, AZ (US)

(72) Inventors: **Arlen Olsen**, Clifton Park, NY (US); **Joel Price**, Germantown, MD (US)

(73) Assignee: **BANNACK MEDICAL LLC**, Gilbert, AZ (US)

(**) Term: **15 Years**

(21) Appl. No.: **29/755,249**

(22) Filed: **Oct. 19, 2020**

(51) **LOC (14) Cl.** **08-11**

(52) **U.S. Cl.**
USPC **D8/369**

(58) **Field of Classification Search**
USPC D8/349, 354-356, 367-369; D6/672, D6/682, 682.3
CPC A44B 13/0029; F16B 45/00; F16B 45/043; F16M 13/02
See application file for complete search history.

(56) **References Cited**

U.S. PATENT DOCUMENTS

168,992 A	10/1875	Hart	
533,152 A	1/1895	Wheat	
588,886 A	8/1897	Smith	
948,687 A	2/1910	Kirkbride	
1,125,749 A	1/1915	Smalley	
1,472,766 A	10/1923	Fraser	
1,581,748 A	4/1926	Lund	
1,658,271 A	2/1928	Lodge	
1,721,338 A	7/1929	Gagnon	
2,045,007 A	6/1936	Carpenter	
2,074,928 A	3/1937	Miller	
2,468,453 A	4/1949	Mallentjer	
2,538,755 A *	1/1951	Bradley A47H 15/02

74/25

2,544,516 A	3/1951	Walters
2,594,605 A	4/1952	Zoppelt
2,952,315 A	9/1960	Brontman
2,968,205 A	1/1961	Springate
2,971,213 A	2/1961	Johnson
2,980,946 A	4/1961	Del Faro et al.
3,002,239 A	10/1961	Noboru

(Continued)

FOREIGN PATENT DOCUMENTS

CH	357511 A5	9/1986
EP	2428142 A2	3/2012

(Continued)

OTHER PUBLICATIONS

Office Action (dated Nov. 9, 2021) for U.S. Appl. No. 16/933,545, filed Jul. 20, 2020.

(Continued)

Primary Examiner — Kelley A Donnelly
(74) *Attorney, Agent, or Firm* — Schmeiser, Olsen & Watts, LLP

(57) **CLAIM**

The ornamental design for a hook attachment, as shown and described.

DESCRIPTION

FIG. 1 is a top front perspective view of a hook attachment showing our new design;
FIG. 2 is a first side view thereof;
FIG. 3 is an opposite side view thereof;
FIG. 4 is a front view thereof;
FIG. 5 is a rear view thereof;
FIG. 6 is a top view thereof; and,
FIG. 7 is a bottom view thereof.
The broken lines depict environmental subject matter only and form no part of the claimed design.

1 Claim, 5 Drawing Sheets

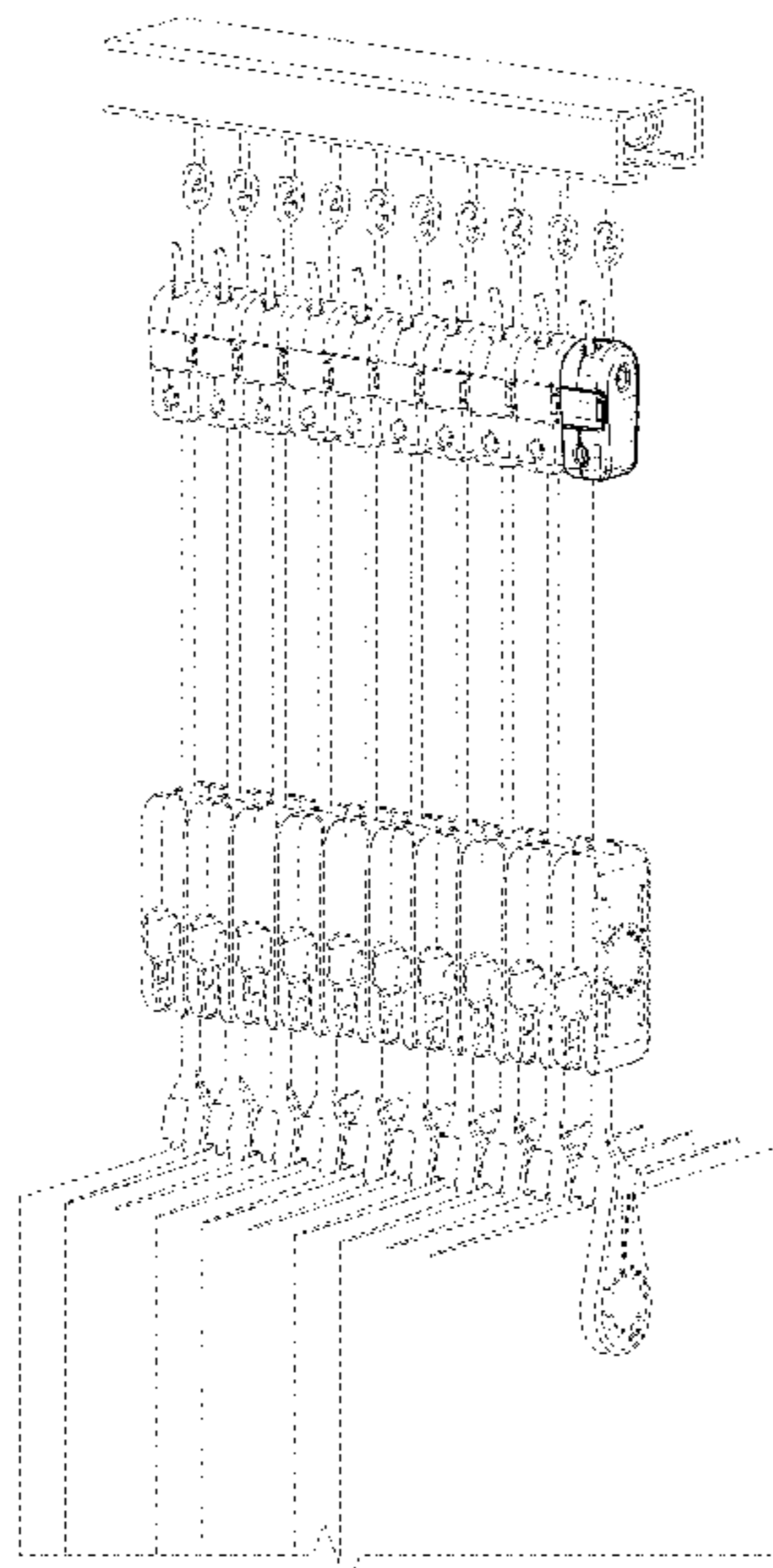

(56)

References Cited

U.S. PATENT DOCUMENTS

3,044,104 A 7/1962 Walz
 3,157,907 A 11/1964 Stall
 3,175,243 A 3/1965 Weber
 3,191,665 A 6/1965 Rosenbaum et al.
 D208,302 S 8/1967 Romano
 3,585,674 A 6/1971 Golden
 3,616,486 A 11/1971 Ford et al.
 3,638,711 A 2/1972 Mazzarelle
 3,645,318 A 2/1972 Holzlehner
 3,712,509 A 1/1973 Niel
 4,010,503 A 3/1977 Denton
 4,091,857 A 5/1978 Jacobs
 4,115,899 A 9/1978 Ford
 4,125,143 A 11/1978 Pape et al.
 4,221,020 A 9/1980 Wertepny
 4,282,630 A 8/1981 Toder
 4,288,891 A 9/1981 Boden
 4,359,080 A 11/1982 Brydolf
 4,473,102 A 9/1984 Ohman et al.
 4,525,893 A 7/1985 Fukada
 4,606,455 A 8/1986 Grikis et al.
 4,675,939 A 6/1987 Fukada
 4,684,022 A 8/1987 Potucek
 4,793,399 A 12/1988 Pryor
 5,111,867 A 5/1992 Horton et al.
 5,193,252 A 3/1993 Svehaug
 5,217,057 A 6/1993 Hubbard et al.
 D337,516 S 7/1993 Williams
 5,282,292 A 2/1994 Levy
 5,291,632 A 3/1994 Akashi
 5,365,641 A 11/1994 Watanabe
 5,421,059 A 6/1995 Leffers, Jr.
 5,518,058 A 5/1996 Gastmann
 5,806,141 A 9/1998 Kolisch
 5,903,957 A 5/1999 Le Manchec
 6,000,456 A 12/1999 Neverett
 6,098,699 A 8/2000 Junius
 6,126,005 A 10/2000 Long, Jr.
 6,131,243 A 10/2000 Lee
 6,564,851 B1 5/2003 Liao et al.
 D475,231 S 6/2003 Briles
 6,595,478 B2 7/2003 Lee
 6,654,990 B2 12/2003 Liu
 6,766,849 B1 7/2004 Tseng
 6,938,927 B1 9/2005 Martin et al.
 7,100,661 B1 9/2006 Pittman
 D534,415 S 1/2007 Salice
 7,370,839 B2 * 5/2008 Putman A47H 1/102
 248/261
 7,377,011 B2 5/2008 Sakakura
 7,451,801 B2 11/2008 Park et al.
 7,757,347 B1 7/2010 Wicker
 7,788,769 B2 9/2010 Wicker et al.
 D633,373 S 3/2011 Grenade
 D654,347 S 2/2012 Chen
 D654,349 S 2/2012 Schopf
 8,205,316 B2 6/2012 Chu
 8,307,499 B2 11/2012 Ruffo et al.
 D671,783 S 12/2012 Graneto, III
 D678,042 S 3/2013 Jacobson
 8,397,346 B2 3/2013 Peters et al.
 8,479,800 B2 7/2013 Graneto, III et al.
 D709,714 S 7/2014 Graneto, III
 8,869,869 B2 10/2014 Graneto, III
 8,899,301 B2 12/2014 Graneto, III
 8,904,605 B2 12/2014 Kawaguchi
 D737,126 S 8/2015 Tschan
 9,125,509 B2 9/2015 Graneto, III
 9,125,511 B2 9/2015 Kao et al.
 9,149,144 B2 10/2015 Graneto, III
 9,204,749 B1 12/2015 Trapani
 D748,753 S * 2/2016 Chow D22/108
 9,480,357 B2 11/2016 Price et al.
 9,578,995 B2 2/2017 Hanley
 9,585,508 B2 3/2017 Graneto, III

9,717,362 B1 8/2017 Birch
 9,742,138 B2 8/2017 Garske et al.
 D807,735 S * 1/2018 Nimgulkar D8/367
 D823,710 S * 7/2018 Schone D11/86
 D836,561 S * 12/2018 Hung D13/155
 10,308,425 B2 6/2019 Corvisier
 10,398,248 B1 9/2019 Burch, Jr.
 10,758,072 B2 9/2020 Hatton et al.
 10,945,548 B2 3/2021 Wexler et al.
 10,952,558 B2 3/2021 Choi
 D918,017 S * 5/2021 Park D8/349
 11,122,867 B1 9/2021 Ajaj et al.
 11,191,383 B1 * 12/2021 Hatton A47H 1/04
 11,297,966 B2 4/2022 Monso
 11,297,968 B2 4/2022 Ko
 D953,149 S * 5/2022 Ormsbee D8/367
 D954,536 S * 6/2022 Momin D8/356
 D962,751 S * 9/2022 Olsen D8/369
 D962,752 S * 9/2022 Olsen D8/369
 D962,753 S 9/2022 Olsen et al.
 D963,462 S * 9/2022 Latal D8/354
 11,432,672 B2 9/2022 Olsen et al.
 D965,416 S * 10/2022 Powell D8/356
 D966,075 S * 10/2022 Jones D8/349
 D967,699 S * 10/2022 Padilla D8/367
 2006/0001254 A1 1/2006 Malone
 2006/0260769 A1 11/2006 Nien
 2007/0012346 A1 1/2007 Choi
 2007/0157505 A1 7/2007 Dodge
 2008/0041538 A1 2/2008 Granger
 2009/0094798 A1 4/2009 Yao
 2009/0288785 A1 11/2009 Graneto, III
 2009/0288786 A1 11/2009 Graneto, III
 2010/0139873 A1 6/2010 Gardner
 2011/0061819 A1 3/2011 Elinson
 2011/0283479 A1 11/2011 Peters et al.
 2011/0290966 A1 12/2011 Ota
 2012/0018106 A1 1/2012 Robledo
 2012/0145860 A1 6/2012 Ruffo et al.
 2013/0047331 A1 2/2013 Parker et al.
 2014/0284005 A1 9/2014 Kao et al.
 2015/0113769 A1 4/2015 Yu
 2015/0129141 A1 5/2015 Kao et al.
 2015/0136340 A1 5/2015 Graneto, III
 2015/0208843 A1 7/2015 Ruble et al.
 2016/0037953 A1 2/2016 Price et al.
 2016/0374496 A1 12/2016 Marcinik et al.
 2017/0208981 A1 7/2017 Nir et al.
 2017/0273492 A1 9/2017 Hatton et al.
 2018/0020860 A1 1/2018 Thomas
 2018/0279818 A1 10/2018 Goelst
 2020/0288896 A1 9/2020 Dames
 2020/0383510 A1 12/2020 Ko
 2022/0015564 A1 1/2022 Olsen et al.
 2022/0015565 A1 1/2022 Olsen et al.
 2022/0015566 A1 1/2022 Olsen et al.
 2022/0015567 A1 1/2022 Olsen et al.
 2022/0240707 A1 8/2022 Roberts et al.
 2022/0265078 A1 8/2022 Hsu et al.

FOREIGN PATENT DOCUMENTS

EP 3308680 A2 4/2018
 GB 2358123 A 7/2001
 GB 2385511 A 8/2003
 GB 2457075 B 10/2011
 GB 2489485 A 10/2012
 GB 2493773 A 2/2013
 KR 101895219 B1 2/1910
 TW M587965 U 12/2019

OTHER PUBLICATIONS

Notice of Allowance (dated Feb. 4, 2022) for U.S. Appl. No. 16/933,545, filed Jul. 20, 2020.
 Notice of Allowance (dated Mar. 9, 2022) for U.S. Appl. No. 29/755,246, filed Oct. 19, 2020.

(56)

References Cited

OTHER PUBLICATIONS

Notice of Allowance (dated Mar. 9, 2022) for U.S. Appl. No. 29/755,256, filed Oct. 19, 2020.

Notice of Allowance (dated Mar. 9, 2022) for U.S. Appl. No. 29/755,257, filed Oct. 19, 2020.

PCT International Search Report & Written Opinion dated Jan. 5, 2022 corresponding to PCT International Application No. PCT/US2021/046604.

PCT International Search Report & Written Opinion dated Jan. 27, 2022 corresponding to PCT International Application No. PCT/US21/55740.

Notice of Allowance (dated May 3, 2022) for U.S. Appl. No. 16/933,545, filed Jul. 20, 2020.

Notice of Allowance (dated May 2, 2022) for U.S. Appl. No. 29/755,246, filed Oct. 19, 2020.

Notice of Allowance (dated May 12, 2022) for U.S. Appl. No. 29/755,256, filed Oct. 19, 2020.

Notice of Allowance (dated May 2, 2022) for U.S. Appl. No. 29/755,257, filed Oct. 19, 2020.

InControl—SmartGuard Disposable Privacy Curtains; http://globalmedics.co.nz/media/InControl_SmartGuard_Brochure_2.pdf. 12 pages.

Marlux Disposable Hospital Curtains: <https://www.marluxmedical.com/disposable-curtains>. 8 pages.

Opal Health Disposable Curtains Quick Fit System, May 26, 2017. <https://www.youtube.com/watch?v=XsQnyL-REhY>.

Opalhealth: The Fast, hygienic alternative to traditional curtains. <https://opalhealth.co.uk/benefits/>. 4 pages.

Solent Blinds & Curtains: Disposable Curtains: <https://solentblinds.co.uk/commercial/products/disposable-curtains/>. 1 page.

EasyClick: “The Next Generation of Disposable Curtains”. <https://behrens.co.uk/product/easyclick-the-next-generation-of-disposable-curtains/>. 2 pages.

Installing Locking Button in Telescoping Tube, Jul. 29, 2014. <https://www.youtube.com/watch?v=y3V6o3eca0g>.

Halder: Ball Lock Pins self-locking, with T-handle. <https://www.halder.com/eng/Products/Standard-Parts/Machine-and-Fixture-Elements/Ball-Lock-Pins/Ball-Lock-Pins-self-locking-with-T-handle>. 2 pages.

Rapid Refresh Shower Curtains. <https://www.icpmedical.com/docs/product-sheets/Shower-Curtains-RR.pdf>. 1 page.

ICPMedical: Privacy Curtains: <https://icpmedical.com/docs/product-sheets/Privacy-Curtains-RR.pdf>. 2 pages.

EasyClick Disposable Cubicle Curtains. <https://behrens.co.uk/media/EASYCLICK-advert.jpg>; 1 page.

EasyKlip Instructions. Retrieved from <https://www.curtain-tracks.com/610-easyklip-mini-tarp-clip-10-per-pack.html>. 1 page.

EasyKlip Midi Tarp & Banner Clip. <https://www.curtain-tracks.com/610-easyklip-mini-tarp-clip-10-per-pack.html>. 2 pages.

“Halder Ball Lock Pins”, Oct. 23, 2017. <https://youtu.be/qLTZiNngk9c>.

ICPMedical: Privacy Curtains: <https://www.icpmedical.com/Products/Privacy-Curtains>. 2 pages.

“Installing the ICP Medical Rapid Refresh Privacy Curtain”, Jun. 10, 2014. <https://www.youtube.com/embed/azsr7bpMB5U?autoplay=1>.

“Installing the ICP Medical Rapid Refresh Curtain Rods”, Jun. 10, 2014. <https://www.youtube.com/embed/lohmn8UhiRo?autoplay=1>. Hasan, Afzal. Patentability Search Report for Disposable Curtain System, dated Jul. 6, 2020.

Restriction Requirement (dated Aug. 5, 2022) for U.S. Appl. No. 17/004,625, filed Aug. 7, 2020.

Office Action (dated Oct. 28, 2022) for U.S. Appl. No. 17/004,625, filed Aug. 7, 2020.

Restriction Requirement (dated Sep. 6, 2022) for U.S. Appl. No. 17/011,571, filed Sep. 3, 2020.

Restriction Requirement (dated Sep. 13, 2022) for U.S. Appl. No. 17/074,861, filed Oct. 20, 2020.

Restriction Requirement (dated Sep. 28, 2022) for U.S. Appl. No. 17/194,858, filed Mar. 8, 2021.

Restriction Requirement (dated Sep. 13, 2022) for U.S. Appl. No. 17/225,321, filed Apr. 8, 2021.

Restriction Requirement (dated Dec. 28, 2022) for PCT International Application No. PCT/US22/46934—International Filing Date Oct. 18, 2022.

Office Action (dated Nov. 28, 2022) for U.S. Appl. No. 17/011,571, filed Sep. 3, 2020.

Office Action (dated Dec. 27, 2022) for U.S. Appl. No. 17/074,861, filed Oct. 20, 2020.

Office Action (dated Dec. 16, 2022) for U.S. Appl. No. 17/194,858, filed Mar. 8, 2021.

Office Action (dated Dec. 27, 2022) for U.S. Appl. No. 17/225,321, filed Apr. 8, 2021.

* cited by examiner

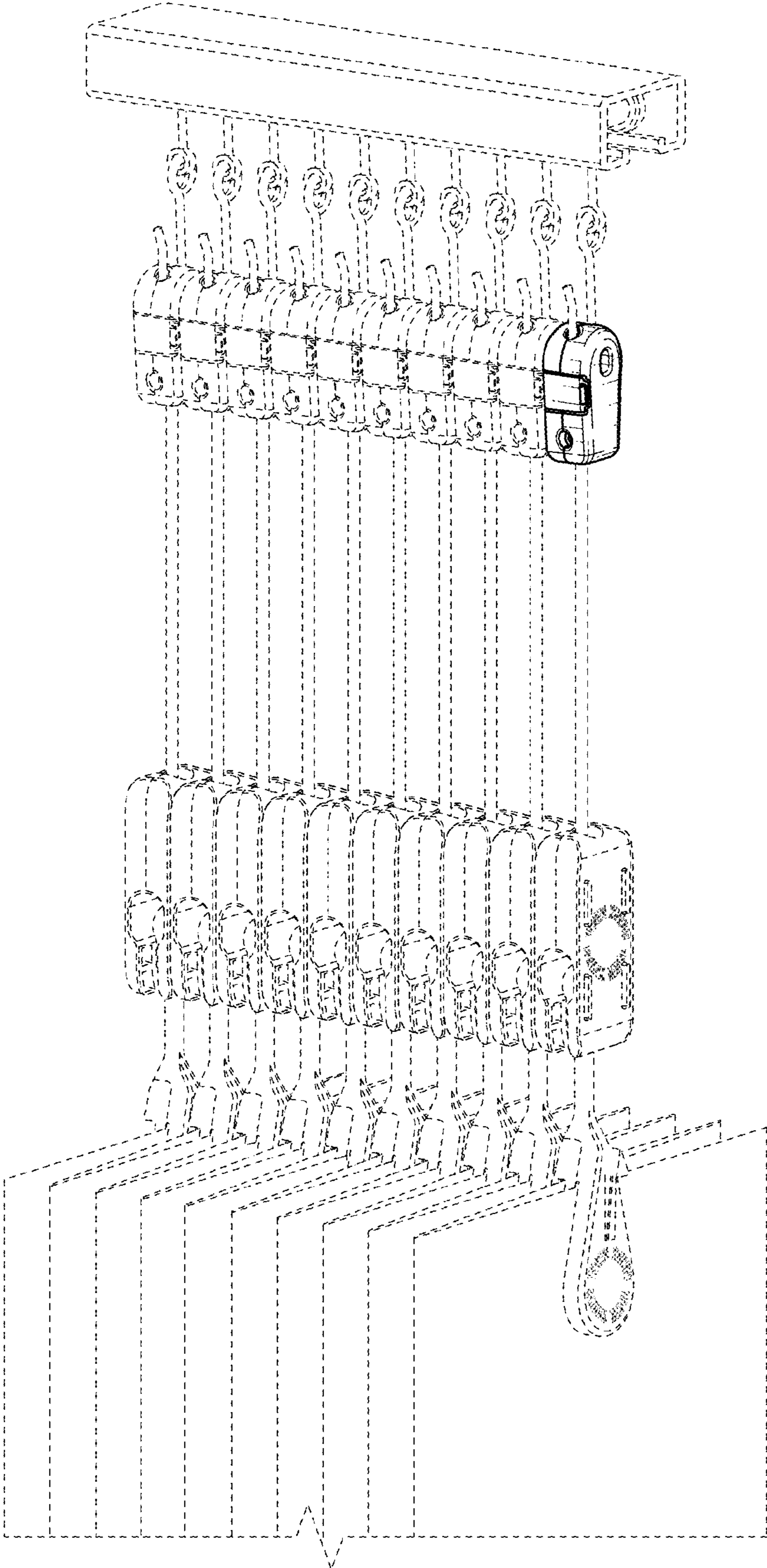

FIG. 1

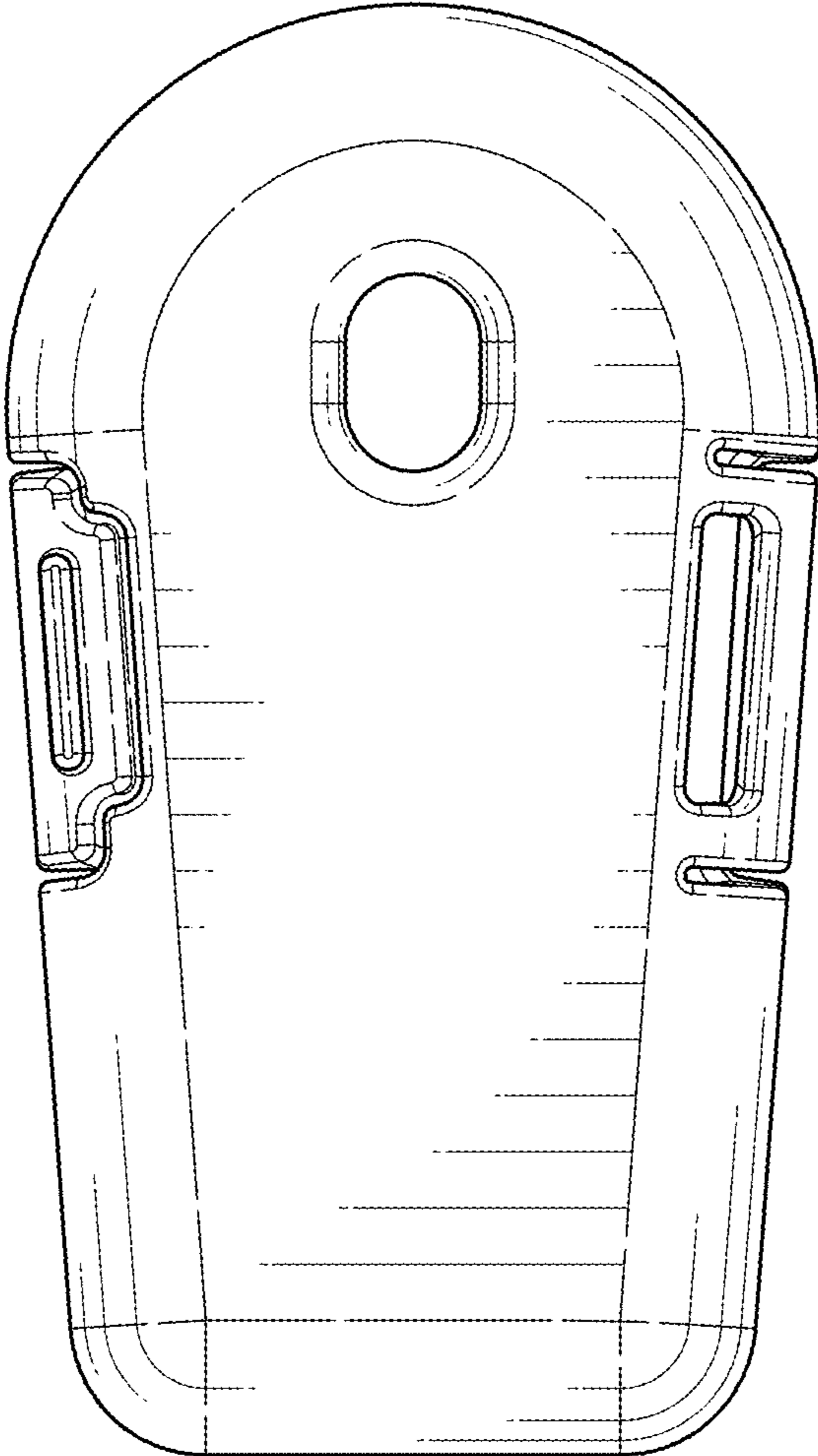

FIG. 2

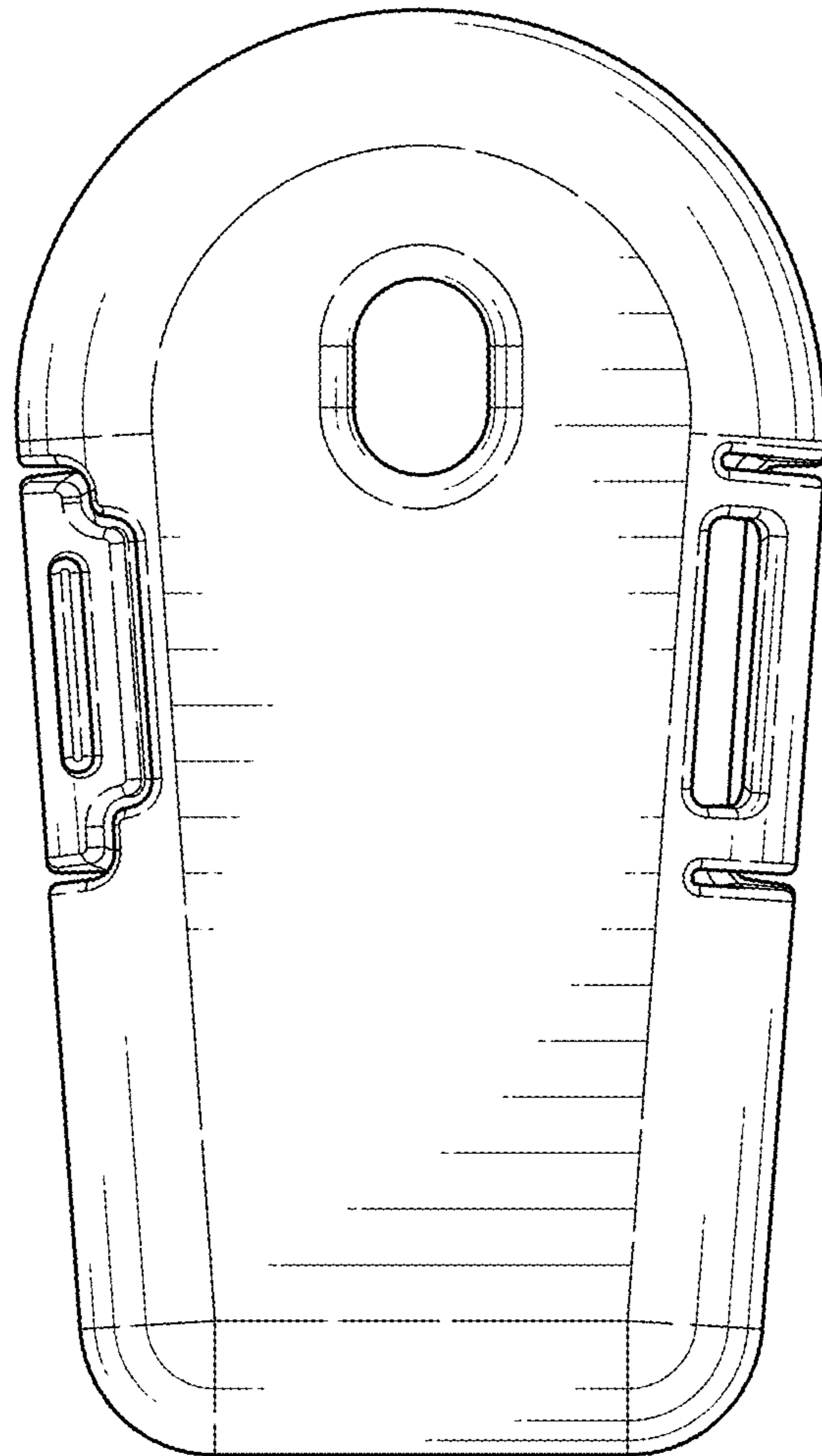

FIG. 3

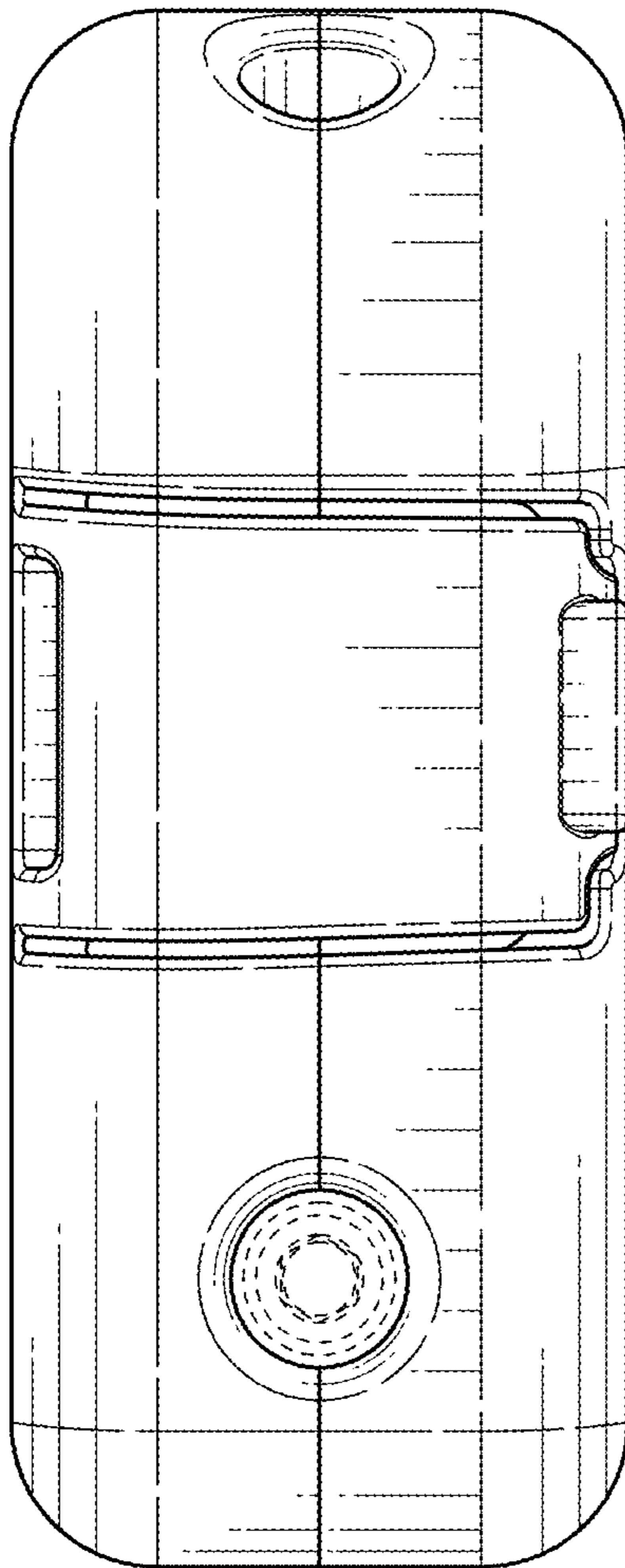

FIG. 4

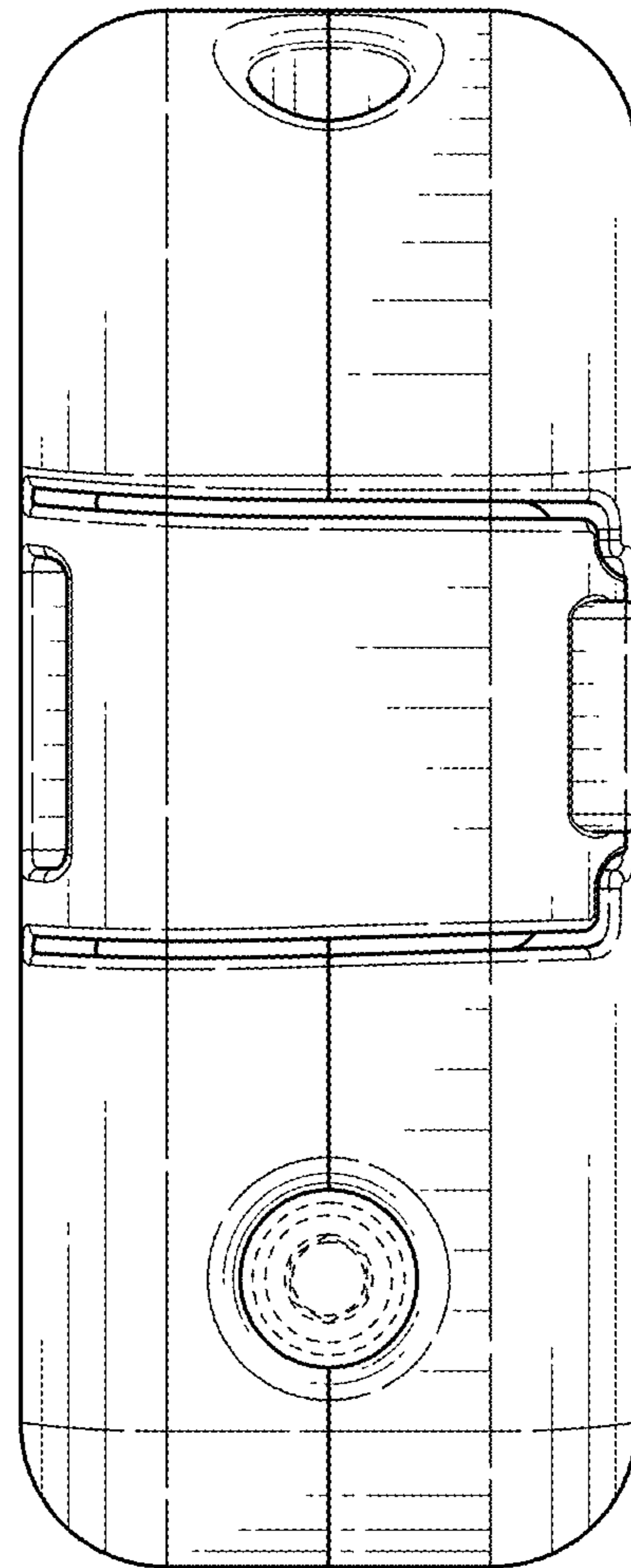

FIG. 5

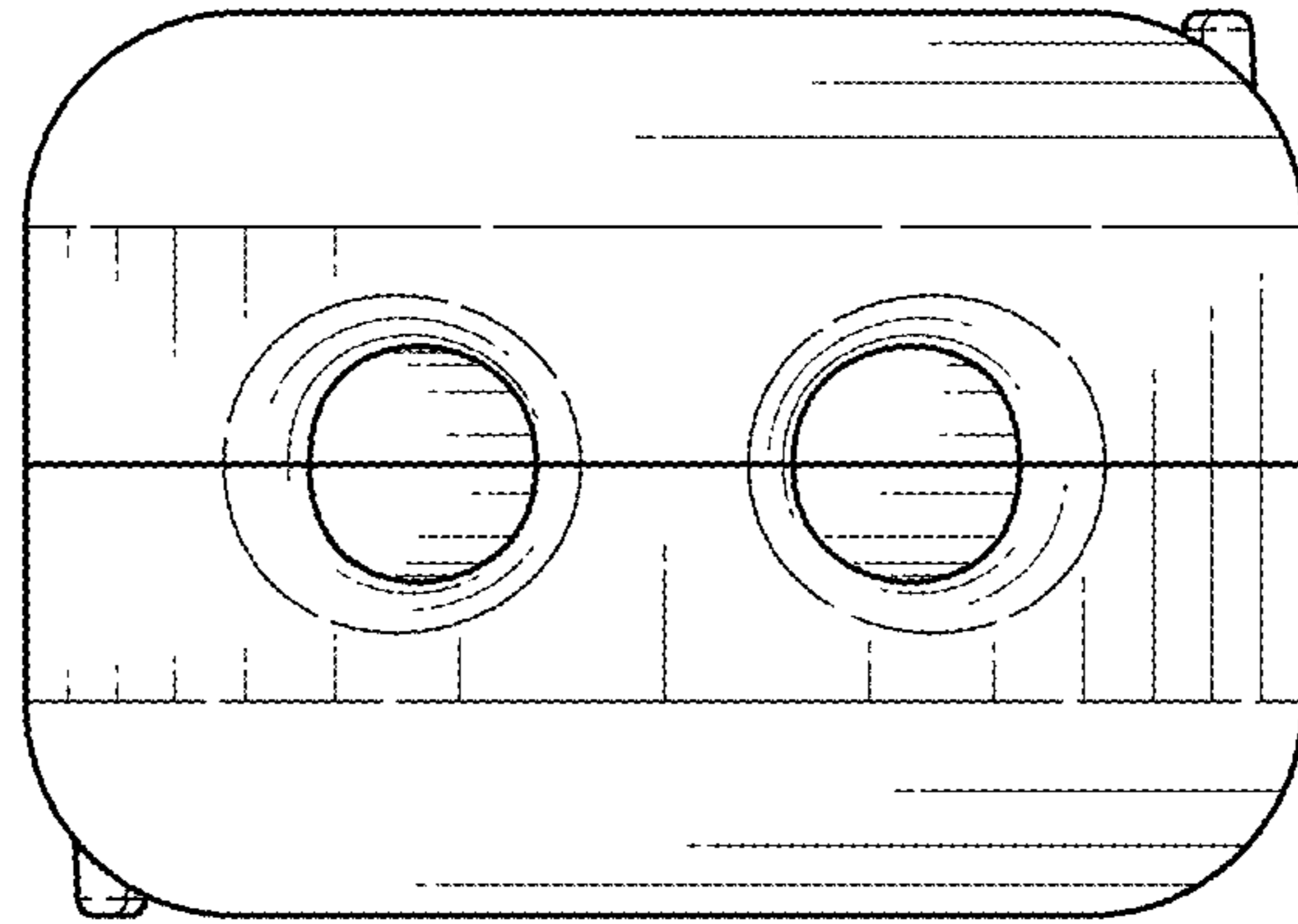

FIG. 6

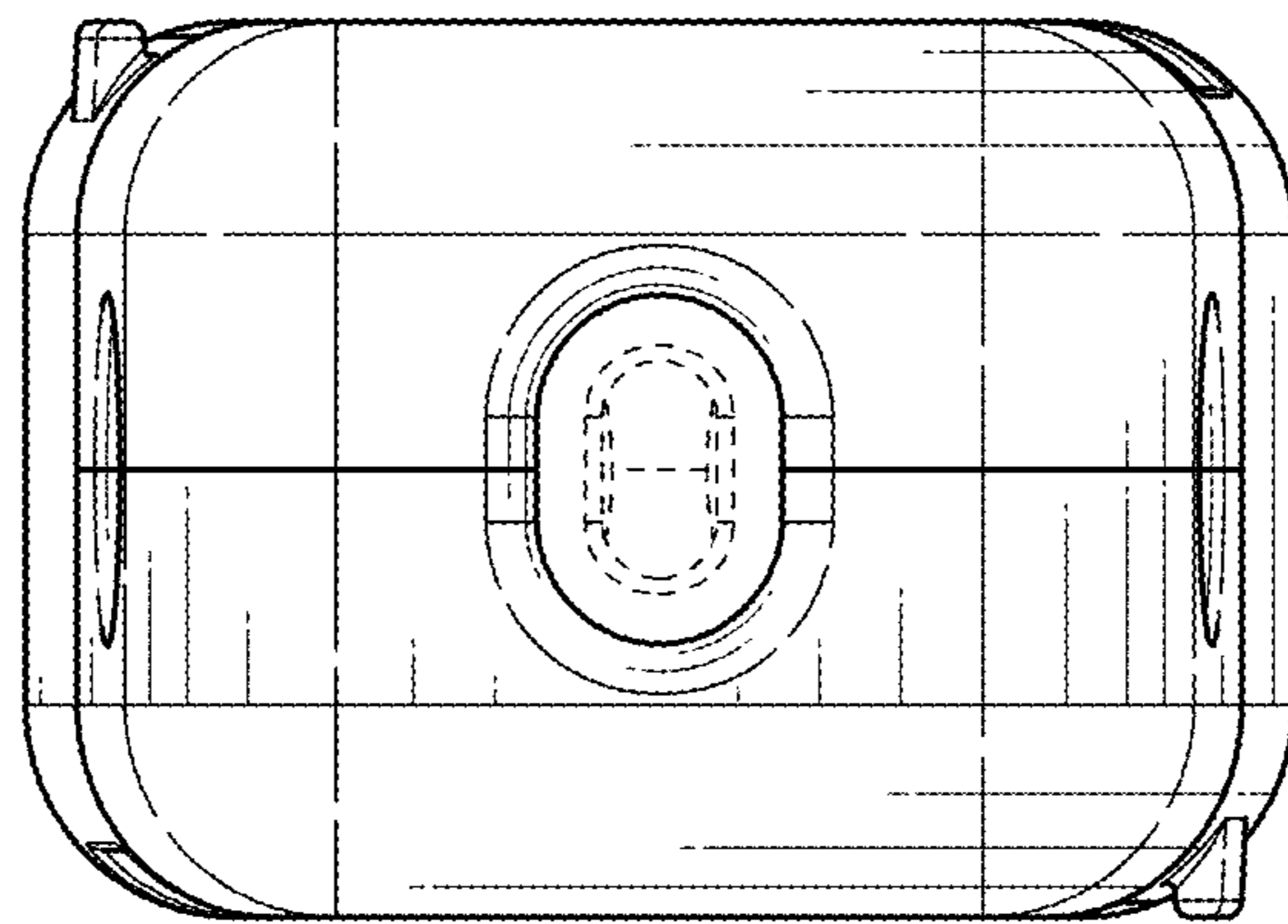

FIG. 7