



US00D981565S

(12) **United States Design Patent**
Zhao

(10) **Patent No.:** **US D981,565 S**
(45) **Date of Patent:** **** Mar. 21, 2023**

(54) **MEDICAL IMAGING APPARATUS**

(57) **CLAIM**

(71) Applicant: **XenseLab LLC**, Irvine, CA (US)

The ornamental design for a medical imaging apparatus, as shown and described.

(72) Inventor: **Ying Zhao**, Irvine, CA (US)

(73) Assignee: **XenseLab LLC**, Irvine, CA (US)

DESCRIPTION

(**) Term: **15 Years**

(21) Appl. No.: **29/795,866**

(22) Filed: **Jun. 21, 2021**

(51) **LOC (14) Cl.** **24-01**

(52) **U.S. Cl.**
USPC **D24/158; D24/159**

(58) **Field of Classification Search**
USPC D24/107, 158–160, 185, 186, 183, 184
(Continued)

(56) **References Cited**

U.S. PATENT DOCUMENTS

4,809,308 A 2/1989 Adams et al.
5,020,086 A 5/1991 Peugeot
(Continued)

FOREIGN PATENT DOCUMENTS

EP 3129957 B1 6/2019
WO WO 2009/012453 A1 1/2009
(Continued)

OTHER PUBLICATIONS

Alvarez, Robert E. et al., “Energy-selective Reconstructions in X-ray Computerized Tomography,” *Physics in Medicine & Biology*, vol. 21, No. 5, 1976, pp. 733-744.
(Continued)

Primary Examiner — Anhdao Doan

(74) *Attorney, Agent, or Firm* — Knobbe, Martens, Olson & Bear, LLP

FIG. 1 is a top perspective view of a first embodiment of a medical imaging apparatus embodying my new design; FIG. 2 is a bottom perspective view thereof; FIG. 3 is a front view thereof; FIG. 4 is a back view thereof; FIG. 5 is a first side view thereof; FIG. 6 is a second side view thereof; FIG. 7 is a top view thereof; FIG. 8 is a bottom view thereof; FIG. 9 is a top perspective view of a second embodiment of a medical imaging apparatus embodying my new design; FIG. 10 is a bottom perspective view thereof; FIG. 11 is a front view thereof; FIG. 12 is a back view thereof; FIG. 13 is a first side view thereof; FIG. 14 is a second side view thereof; FIG. 15 is a top view thereof; FIG. 16 is a bottom view thereof; FIG. 17 is a top perspective view of a third embodiment of a medical imaging apparatus embodying my new design; FIG. 18 is a bottom perspective view thereof; FIG. 19 is a front view thereof; FIG. 20 is a back view thereof; FIG. 21 is a first side view thereof; FIG. 22 is a second side view thereof; FIG. 23 is a top view thereof; FIG. 24 is a bottom view thereof; FIG. 25 is a top perspective view of a fourth embodiment of a medical imaging apparatus embodying my new design; FIG. 26 is a bottom perspective view thereof; FIG. 27 is a front view thereof; FIG. 28 is a back view thereof; FIG. 29 is a first side view thereof; FIG. 30 is a second side view thereof; FIG. 31 is a top view thereof; and, FIG. 32 is a bottom view thereof.

(Continued)

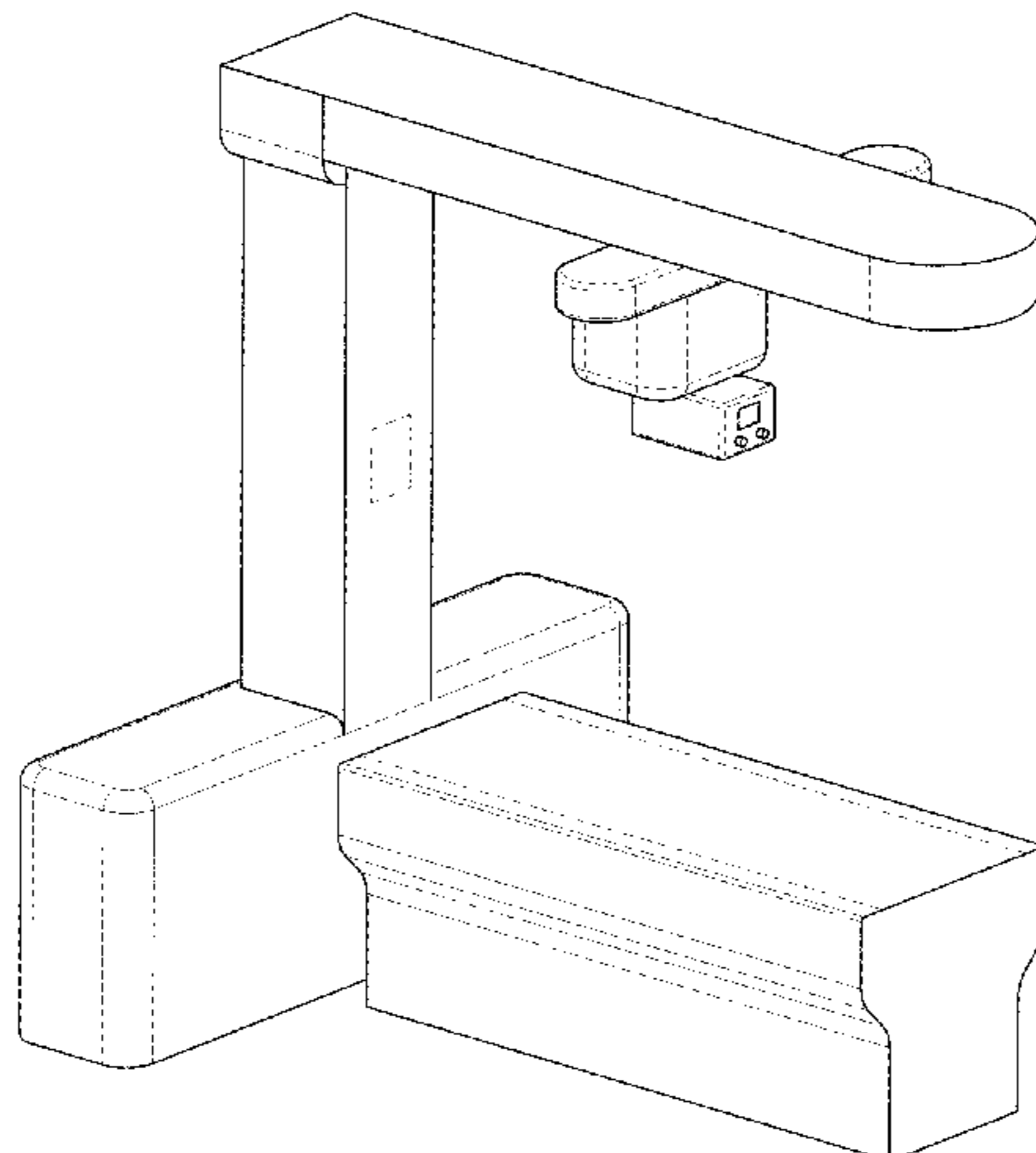

Broken lines are used to illustrate portions of the medical imaging apparatus and form no part of the claimed design.

1 Claim, 32 Drawing Sheets

(58) **Field of Classification Search**

CPC G01N 2223/1016; G01N 2223/301; G01N 2223/031; G01N 2223/419; G01N 23/046; A61B 5/055

See application file for complete search history.

(56) **References Cited**

U.S. PATENT DOCUMENTS

5,097,492	A	3/1992	Baker et al.
5,594,770	A	1/1997	Bowles et al.
5,771,269	A	6/1998	Chao
6,570,955	B1	5/2003	Siffert et al.
6,816,564	B2	11/2004	Charles, Jr. et al.
9,036,879	B2	5/2015	Mendonca et al.
9,579,526	B2	2/2017	Kunz et al.
D889,657	S *	7/2020	Hasebe D24/158
D911,344	S *	2/2021	Zhang D14/420
11,298,095	B2	4/2022	Zhao et al.
11,432,786	B2 *	9/2022	Yamamoto A61B 6/54
2008/0013673	A1	1/2008	Ruhmschopf
2009/0283682	A1	11/2009	Star-Lack et al.
2012/0148133	A1	6/2012	Chen et al.
2013/0307923	A1	11/2013	Inglese et al.
2014/0133729	A1	5/2014	Goshen
2014/0247919	A1	9/2014	Zhang et al.
2015/0287193	A1	10/2015	Kato et al.
2015/0359504	A1	12/2015	Zhou et al.
2016/0095562	A1	4/2016	Baturin et al.
2016/0213344	A1	7/2016	Yi et al.
2018/0067061	A1	3/2018	Butani et al.
2021/0030382	A1 *	2/2021	Sa A61B 6/0407
2021/0137469	A1	5/2021	Zhao
2021/0244374	A1	8/2021	Zhao

FOREIGN PATENT DOCUMENTS

WO	WO 2011/156526	A2	12/2011
WO	WO 2017/144474	A1	8/2017
WO	WO 2017/205612	A1	11/2017
WO	WO 2019/144065	A1	7/2019
WO	WO 2019/183002	A2	9/2019
WO	WO 2020/028422	A1	2/2020
WO	WO 2021/108715	A1	6/2021

OTHER PUBLICATIONS

Gaudreault, David et al., "Comparative Study of Image Quality in Time-Correlated Single Photon Counting Computed Tomography," Journal of Latex Class Files, vol. 14, No. 8, Aug. 2015, in 7 pages.

General Electric Company, "Volume Rad (Tomosynthesis) Reference Guide," Jan. 2011, in 4 pages.

Gordon, Richard, "A Tutorial on Art." IEEE Transactions on Nuclear Science, vol. NS-21, Jun. 1974, in 16 pages.

Inscoe, Christina R., "Stationary Digital Tomosynthesis: Implementation, Characterization, and Image Processing Techniques," The University of North Carolina at Chapel Hill, ProQuest Dissertations Publishing, 2018, in 171 pages.

Mason, Jonathan H., "Quantative cone-beam CT reconstruction with polyenergetic scatter model fusion," Physics in Medicine & Biology, vol. 63, No. 22, Nov. 7, 2018.

McCollough, Cynthia H. et al., Dual- and Multi-Energy CT: Principles, Technical Approaches, and Clinical Applications, Radiology, vol. 276, No. 3 Sep. 2015, pp. 637-653.

Sisniega, A. et al. "High-fidelity artifact correction for cone-beam CT imaging of the brain," Physics in Medicine & Biology, vol. 60, published Jan. 22, 2015, pp. 1415-1439.

Speidel, Michael A., "Inverse geometry x-ray imaging: application in interventional procedures," Journal of the American College of Radiology, vol. 8, Issue 1, Jan. 1, 2011, in 8 pages.

Vedantham, Srinivasan et al., "Digital Breast Tomosynthesis: State of the Art," Radiology, vol. 277, No. 3, Dec. 2015, in 22 pages.

* cited by examiner

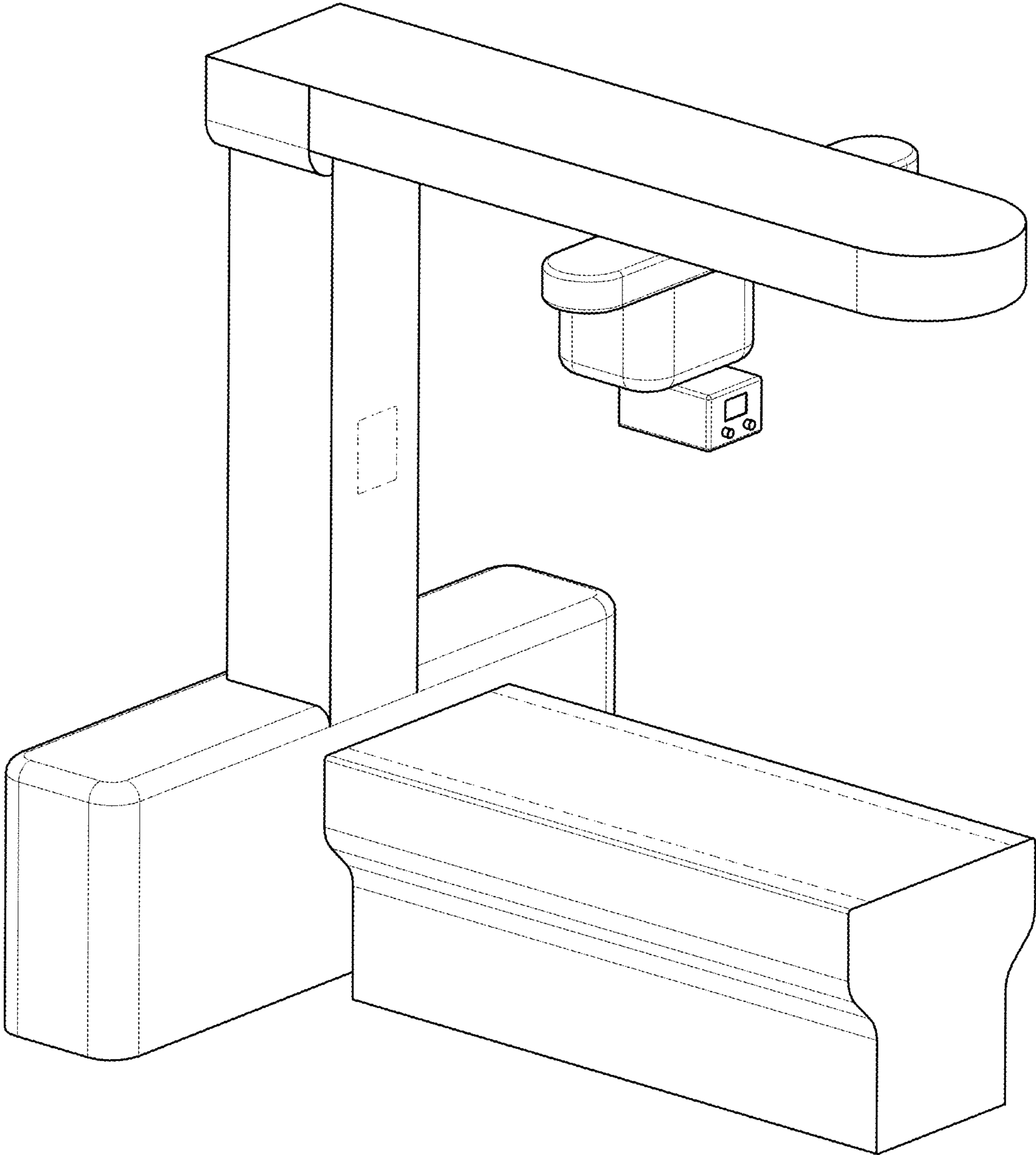

FIG. 1

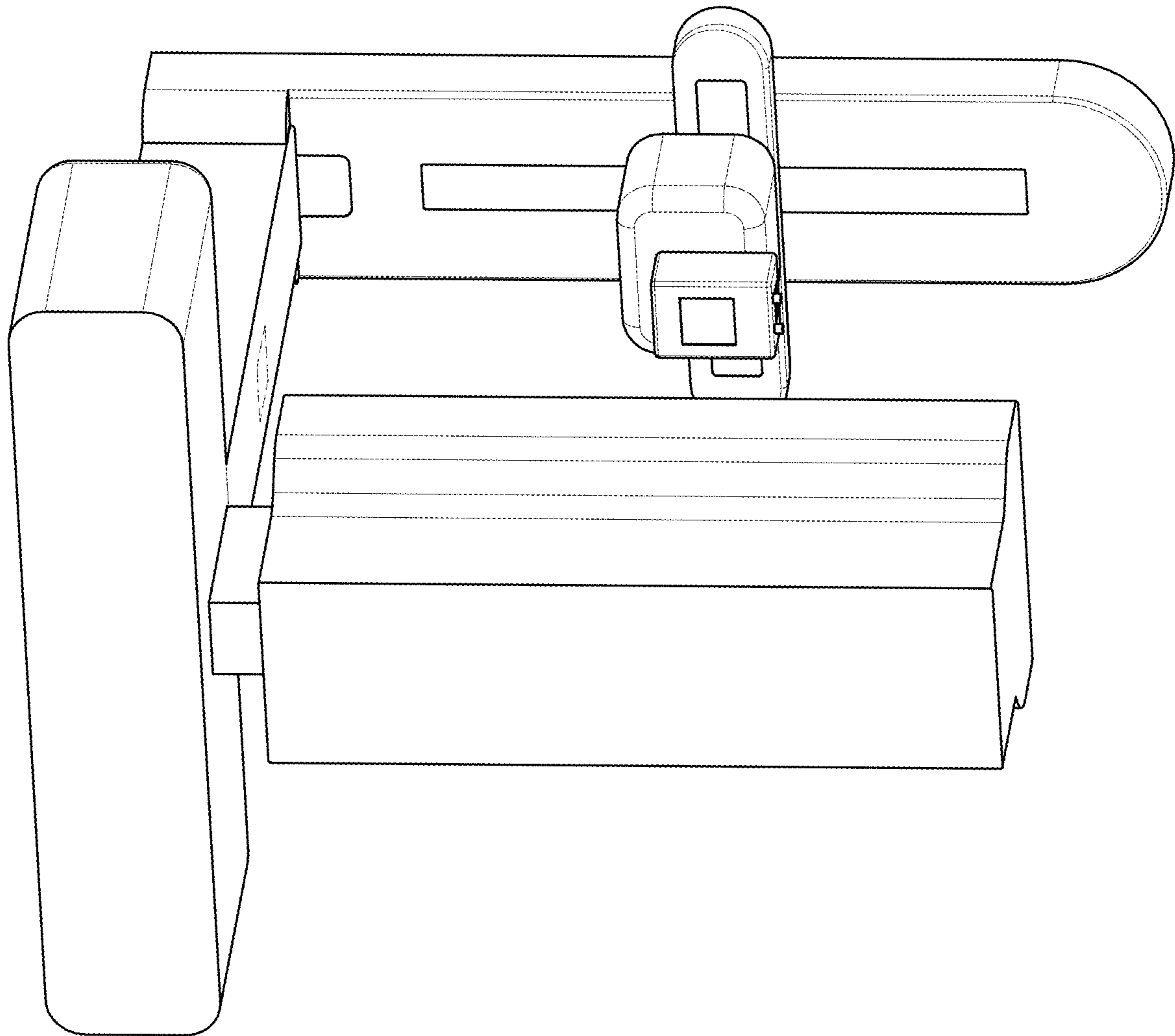

FIG. 2

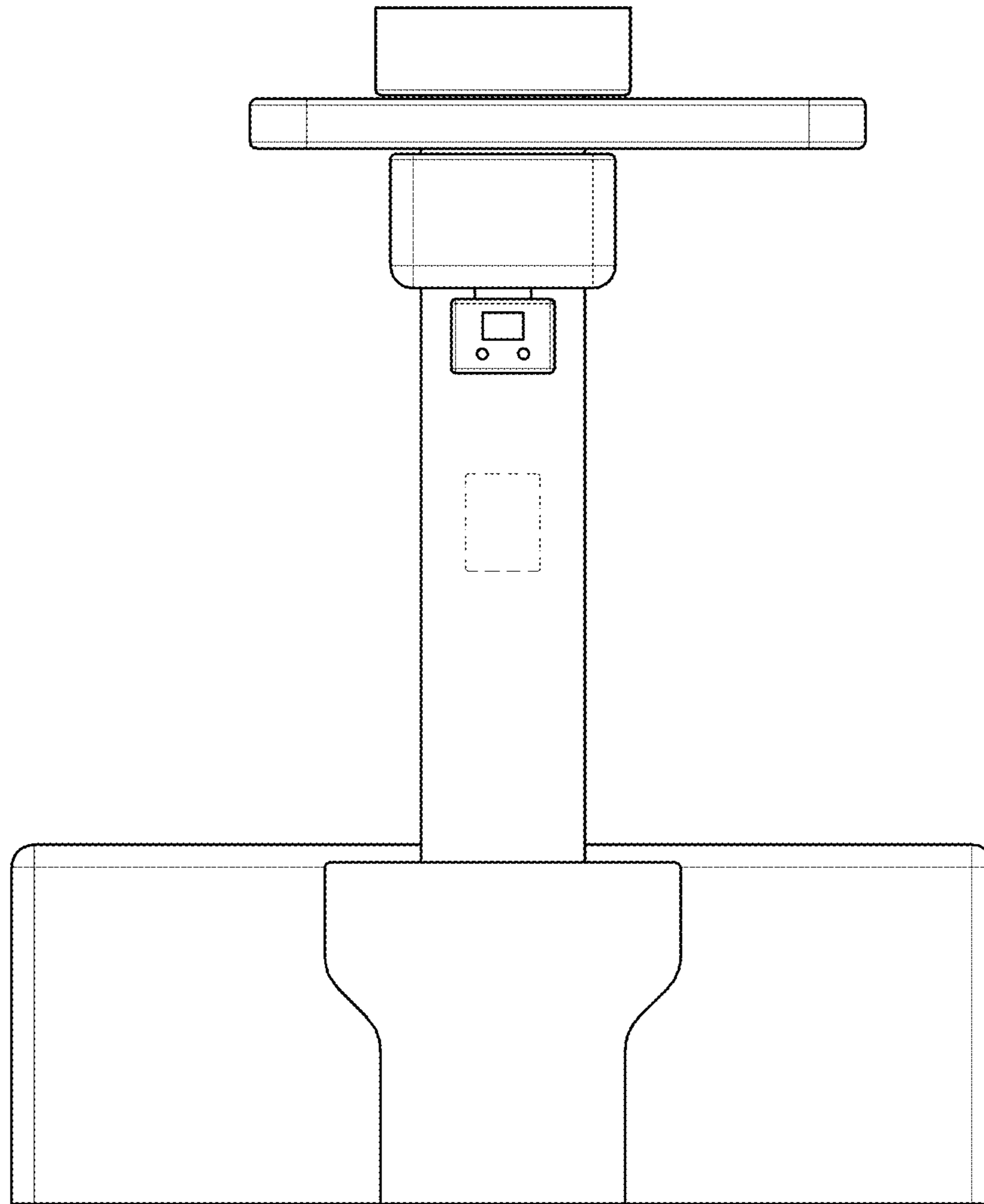

FIG. 3

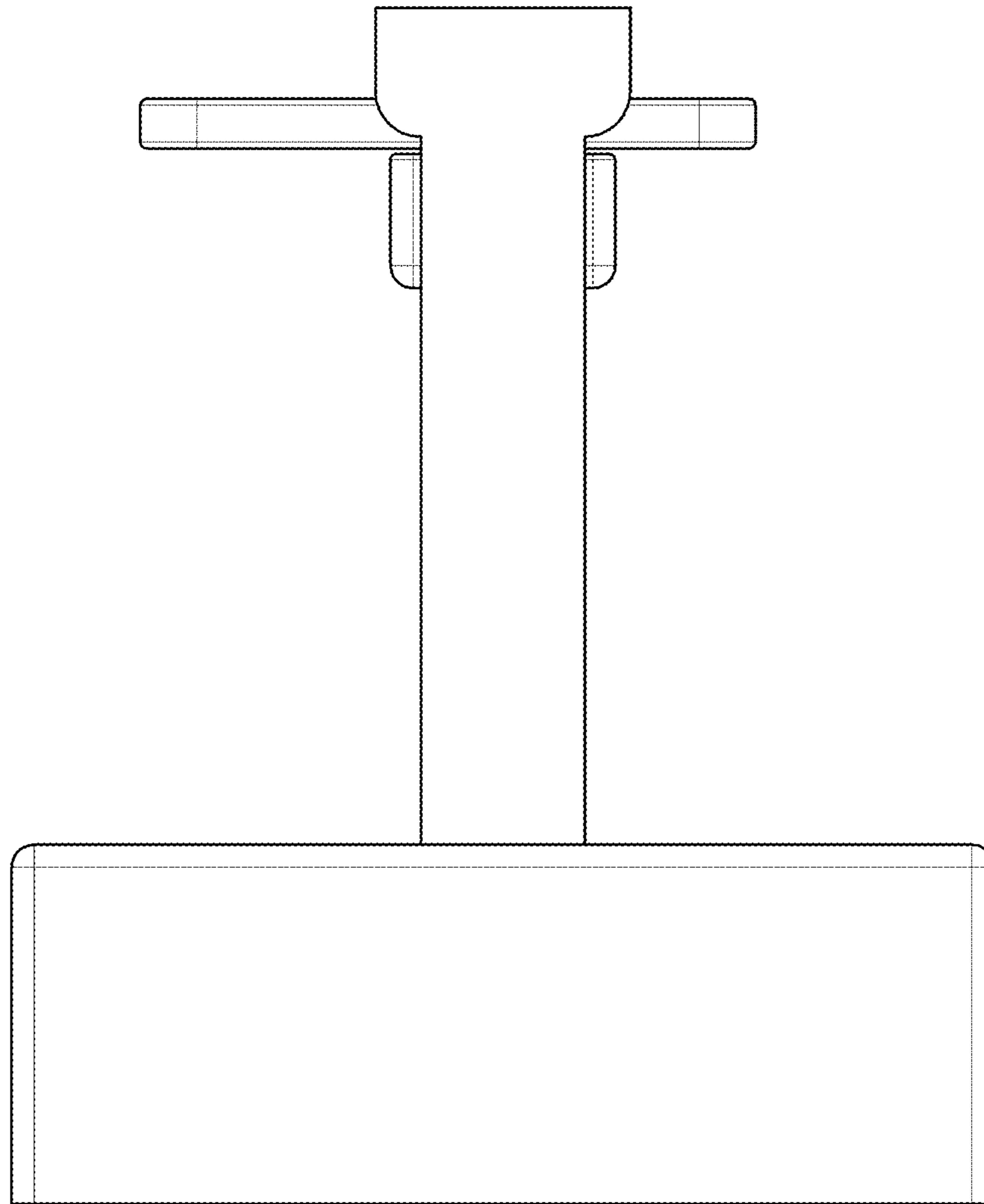

FIG. 4

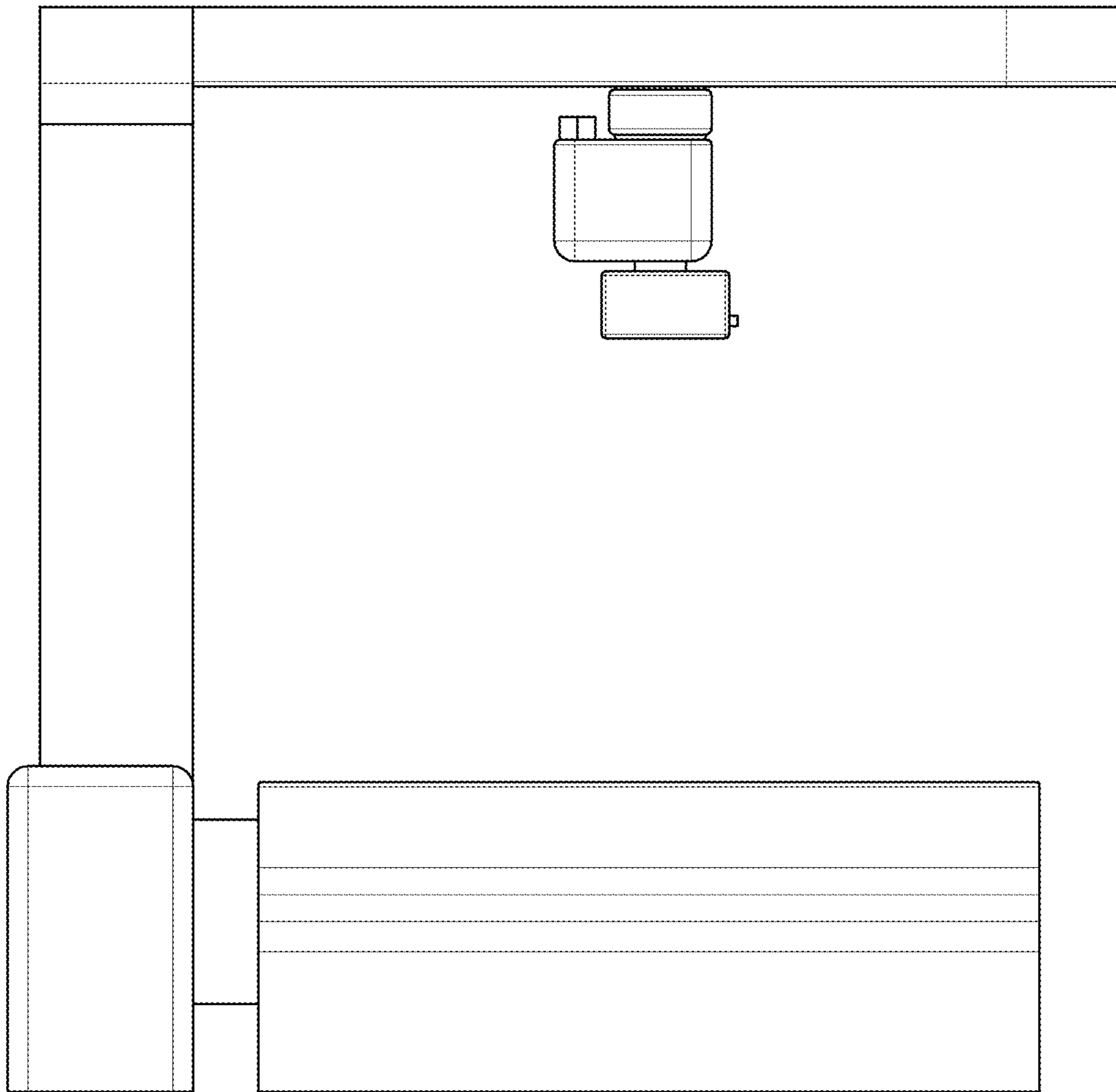

FIG. 5

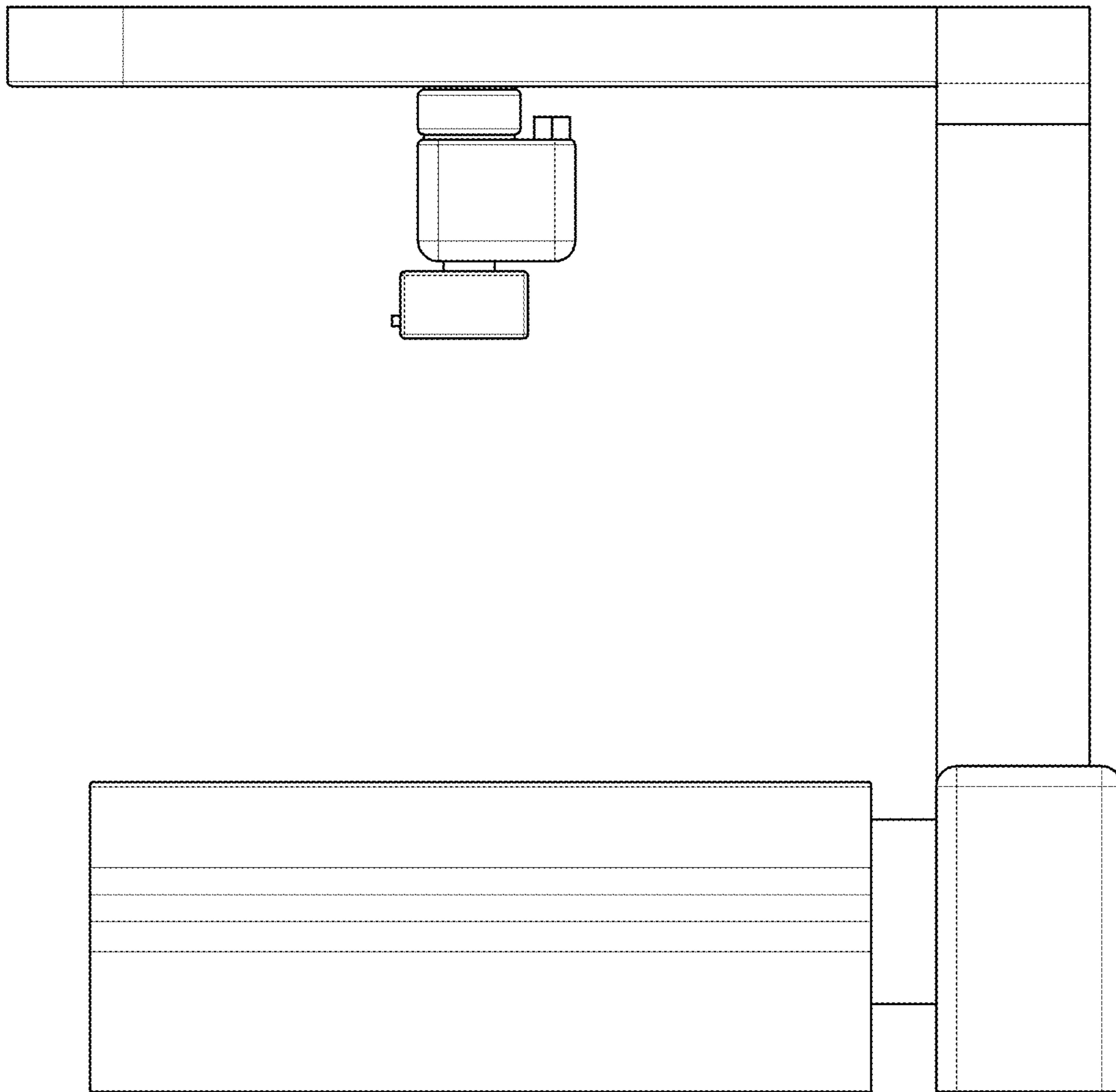

FIG. 6

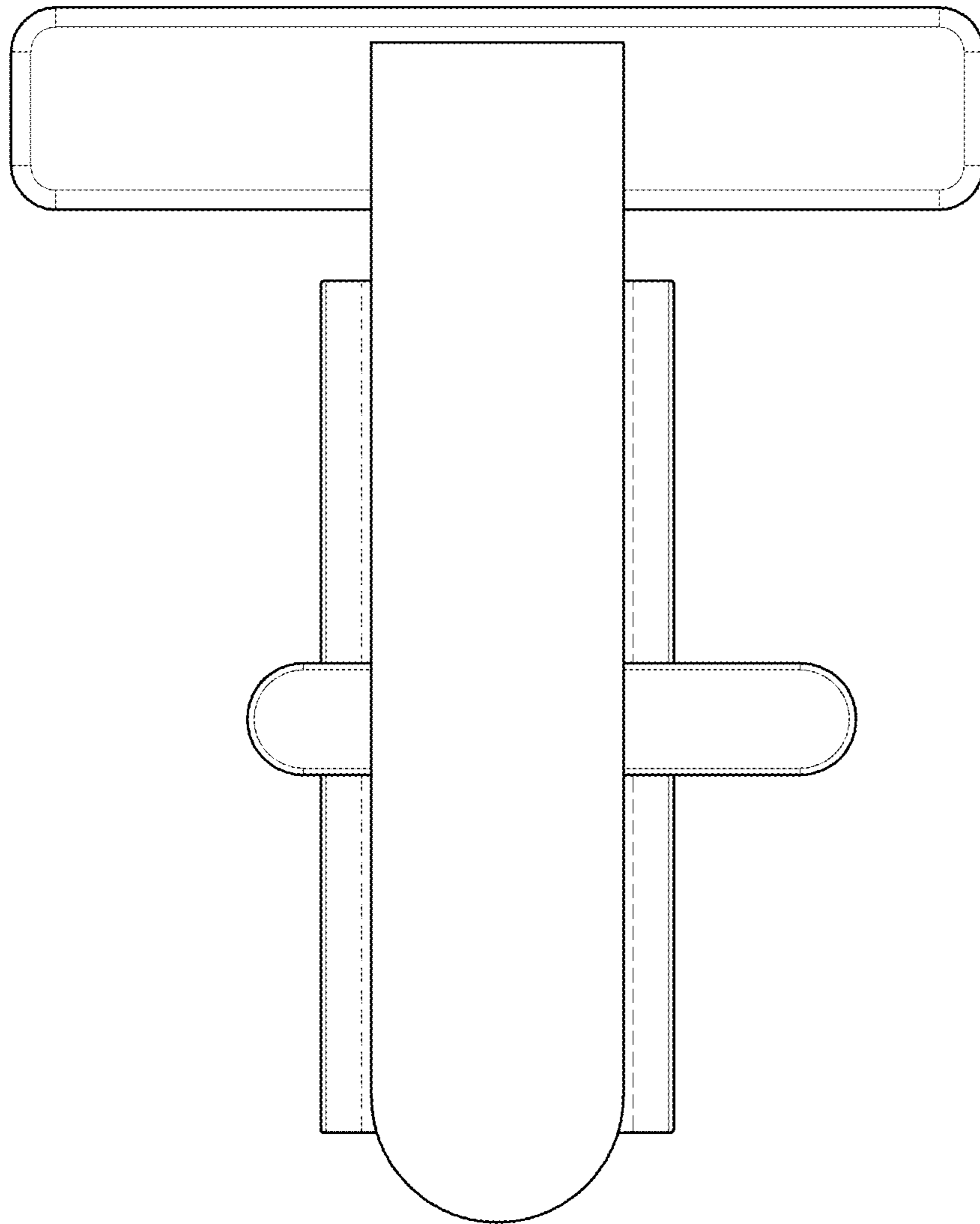

FIG. 7

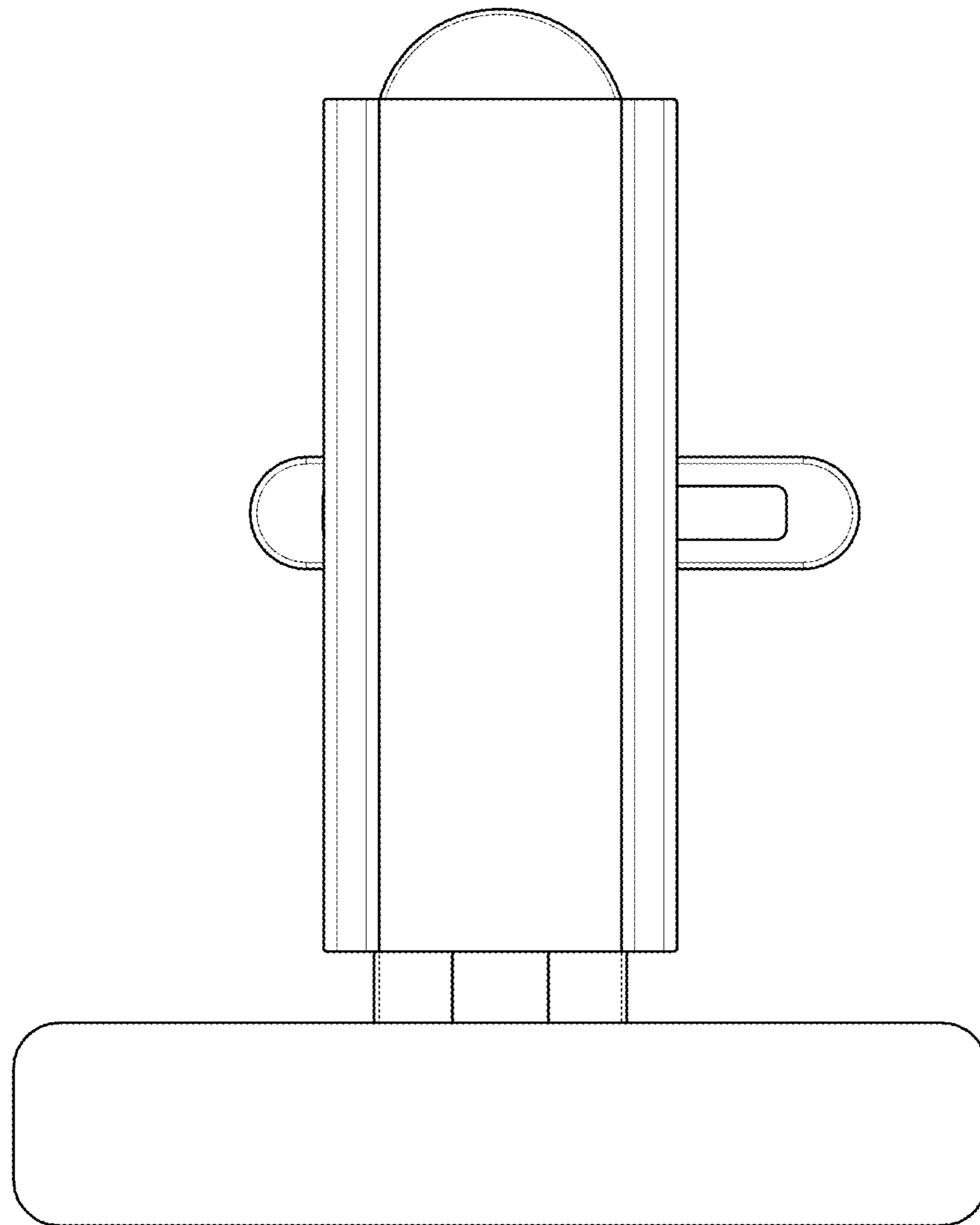

FIG. 8

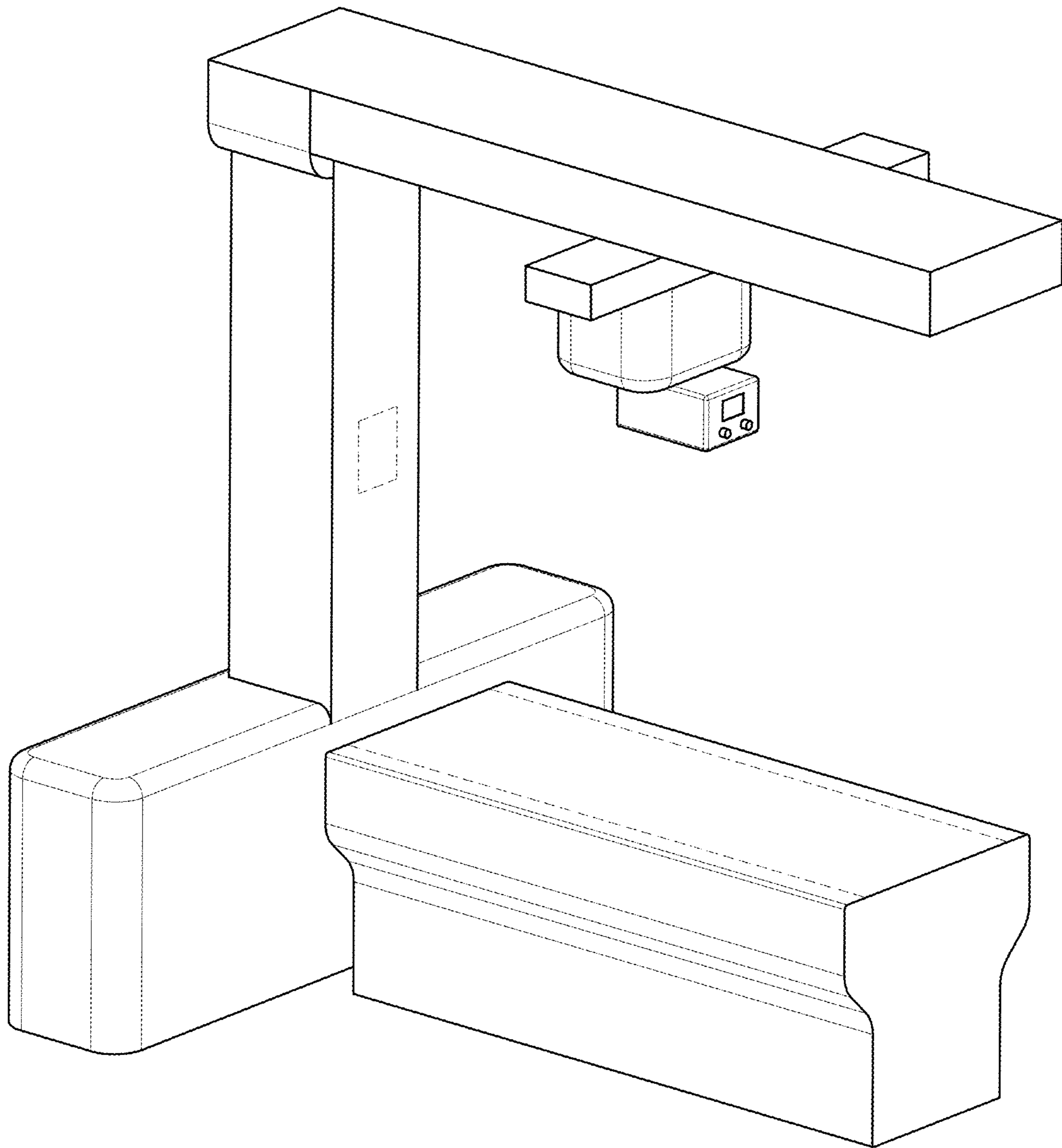

FIG. 9

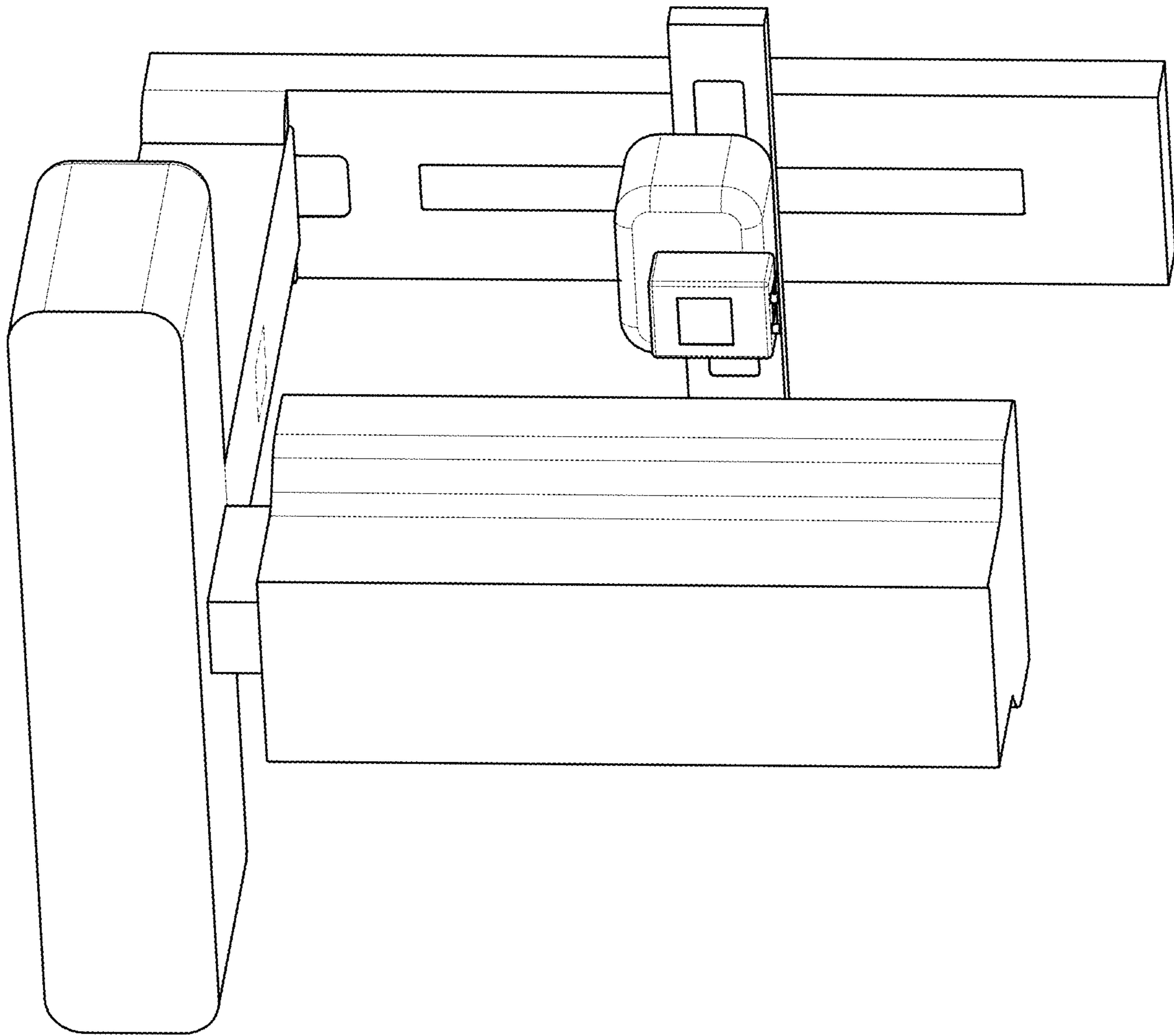

FIG. 10

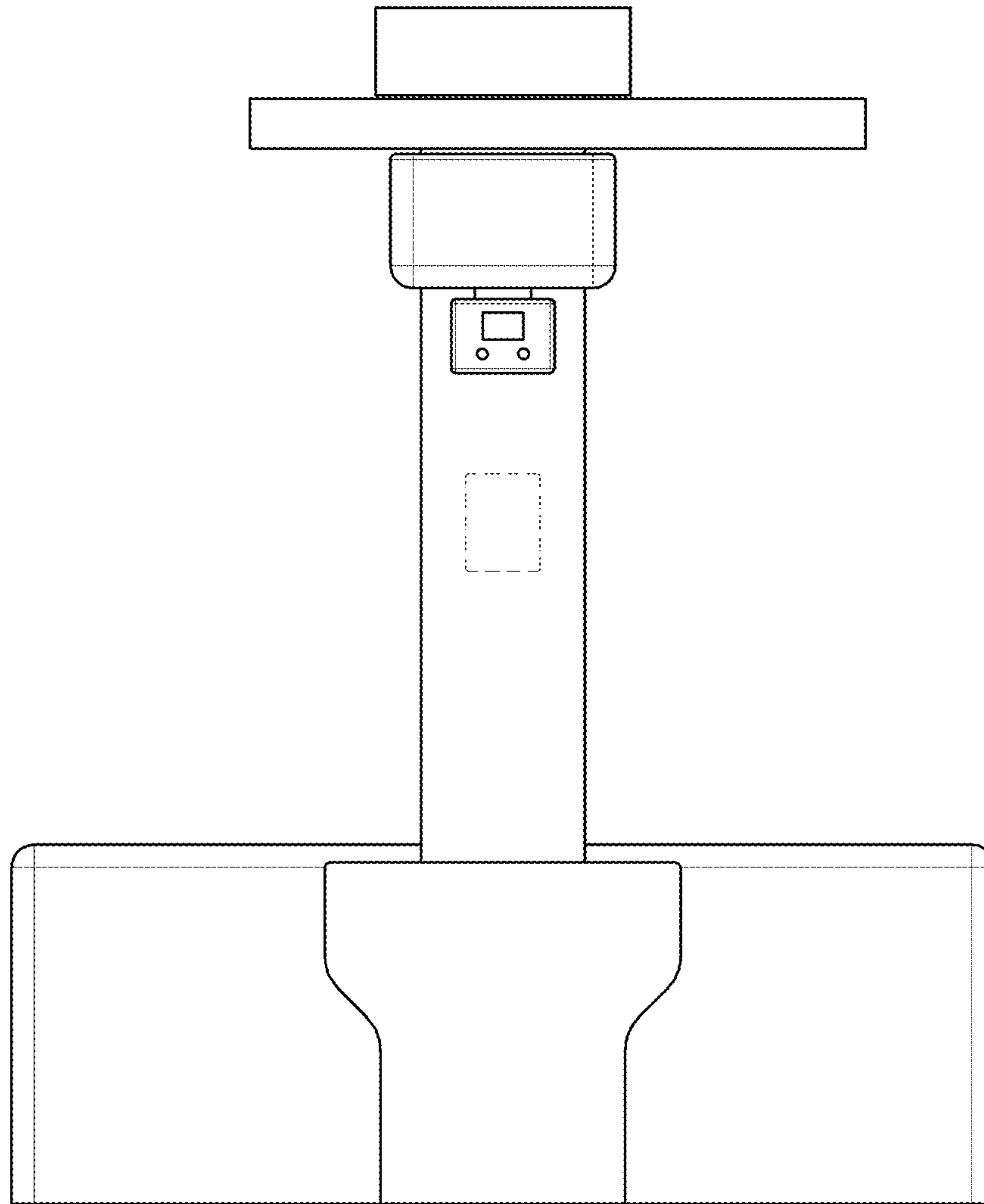

FIG. 11

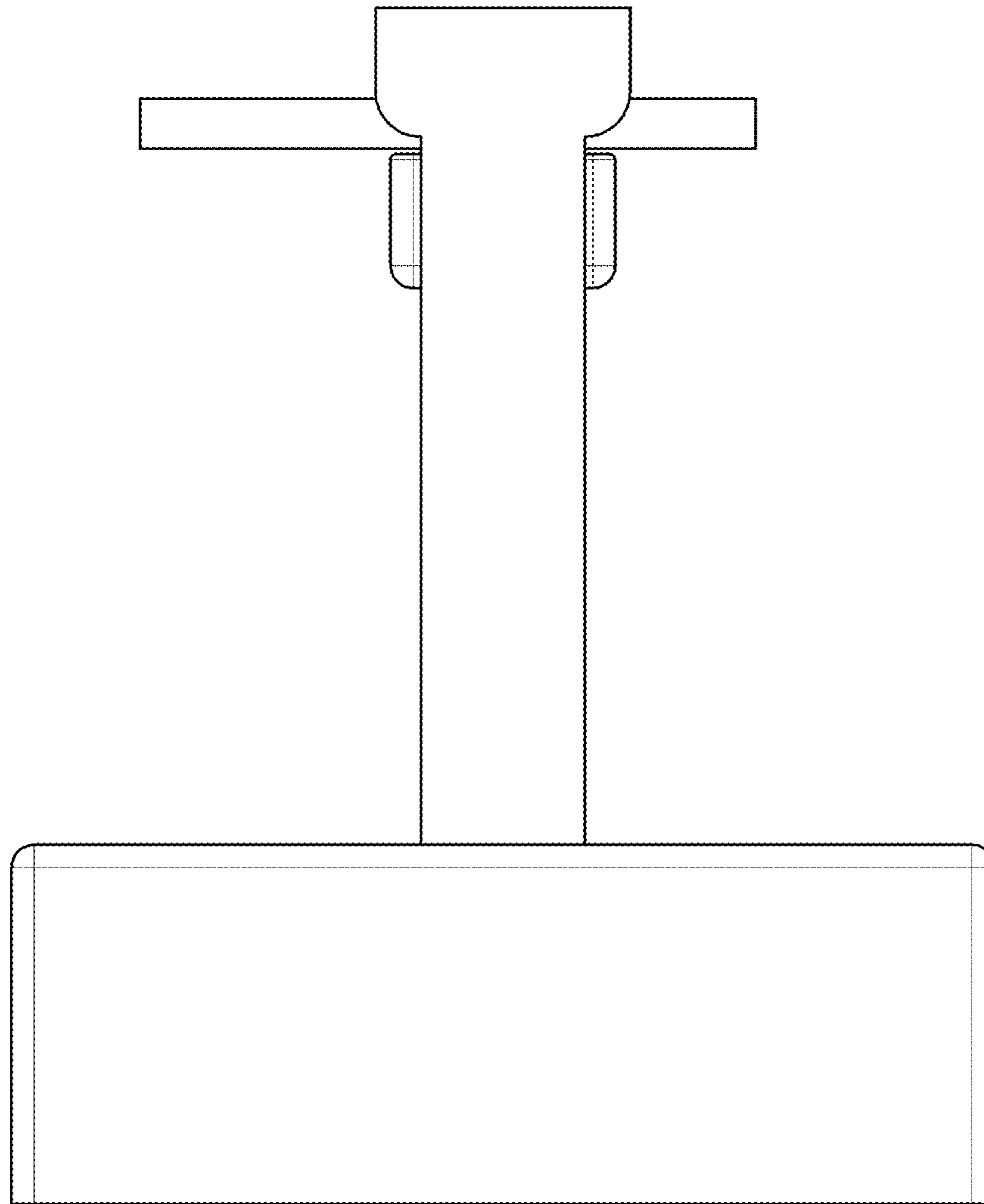

FIG. 12

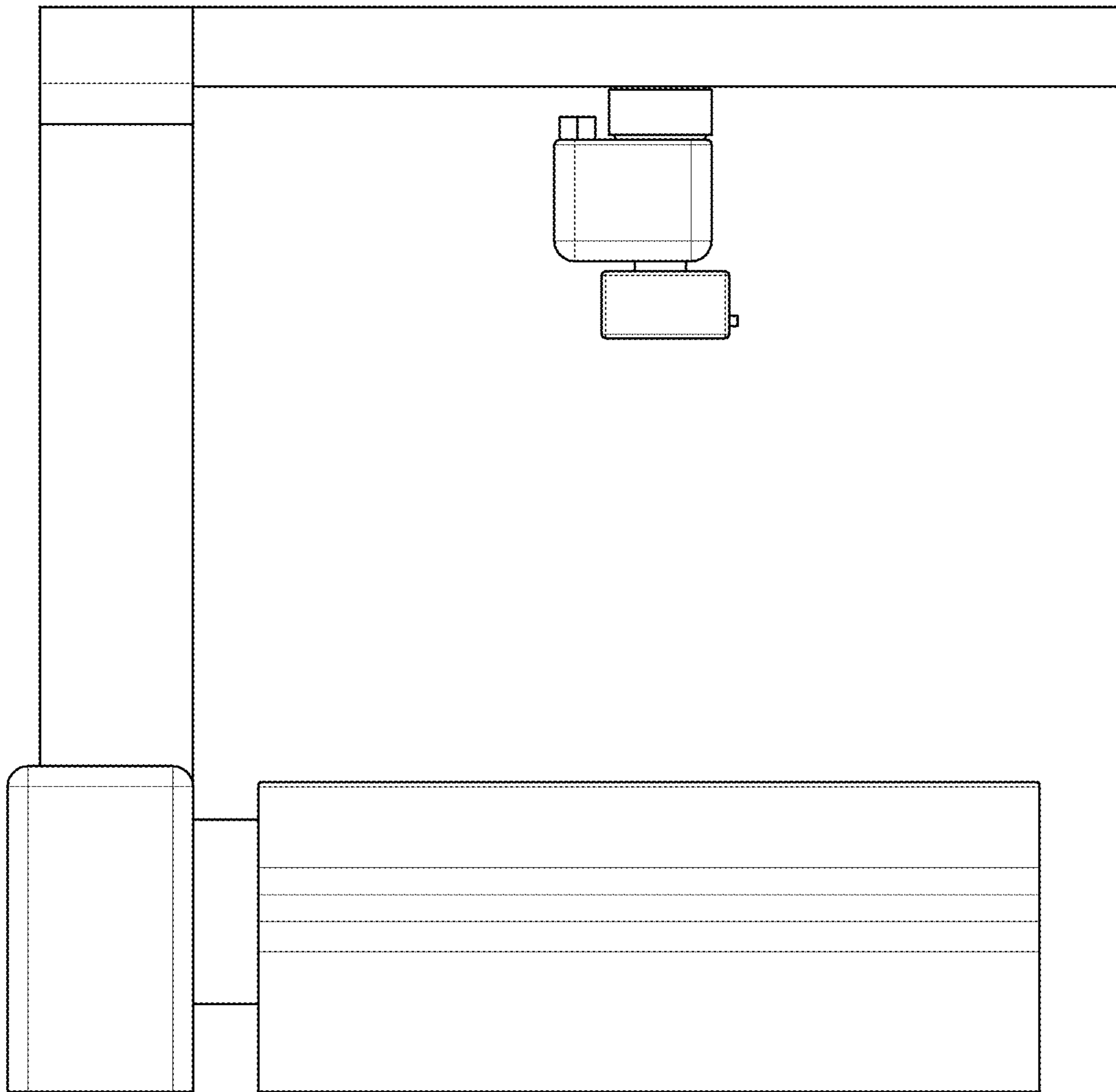

FIG. 13

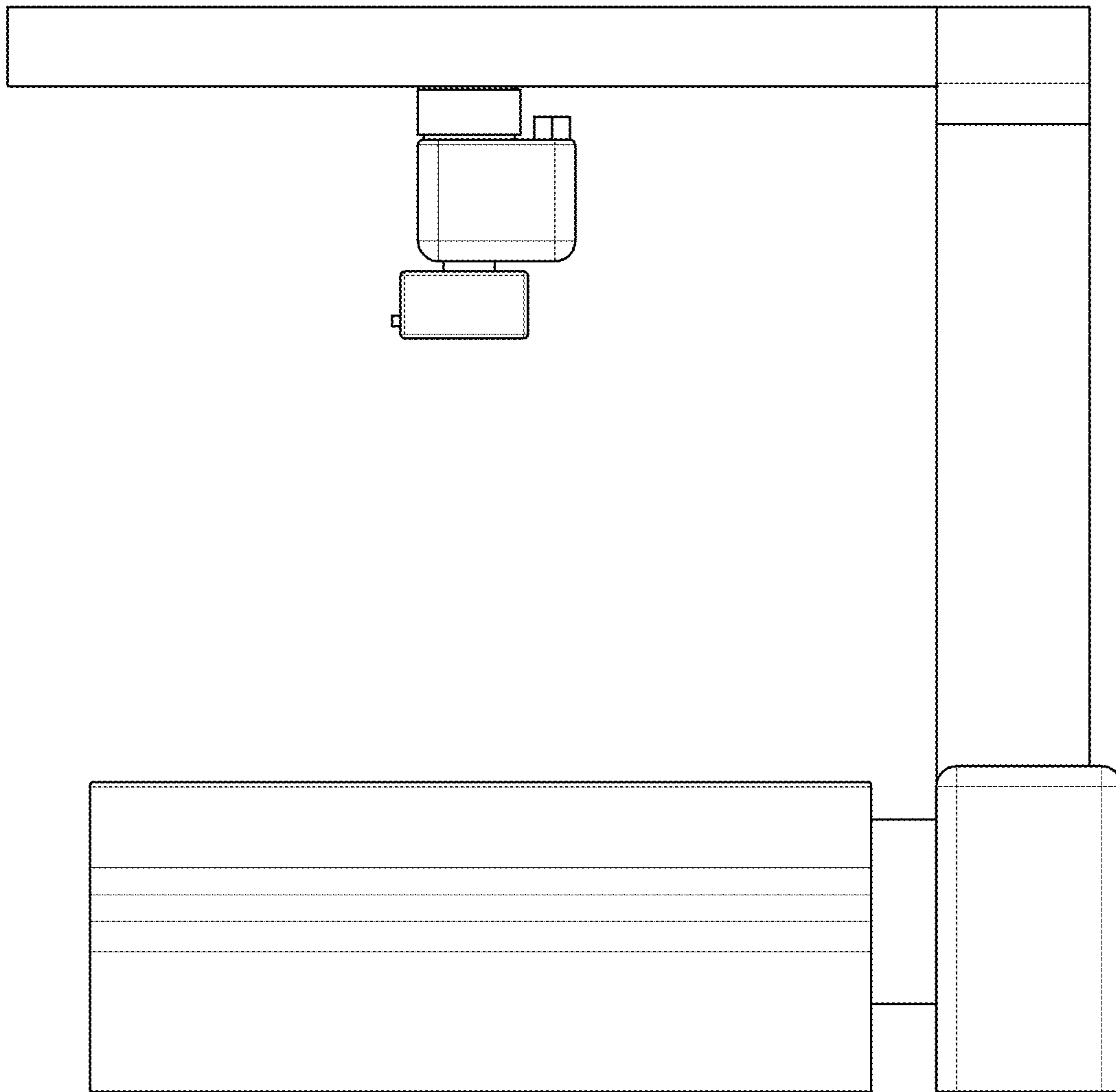

FIG. 14

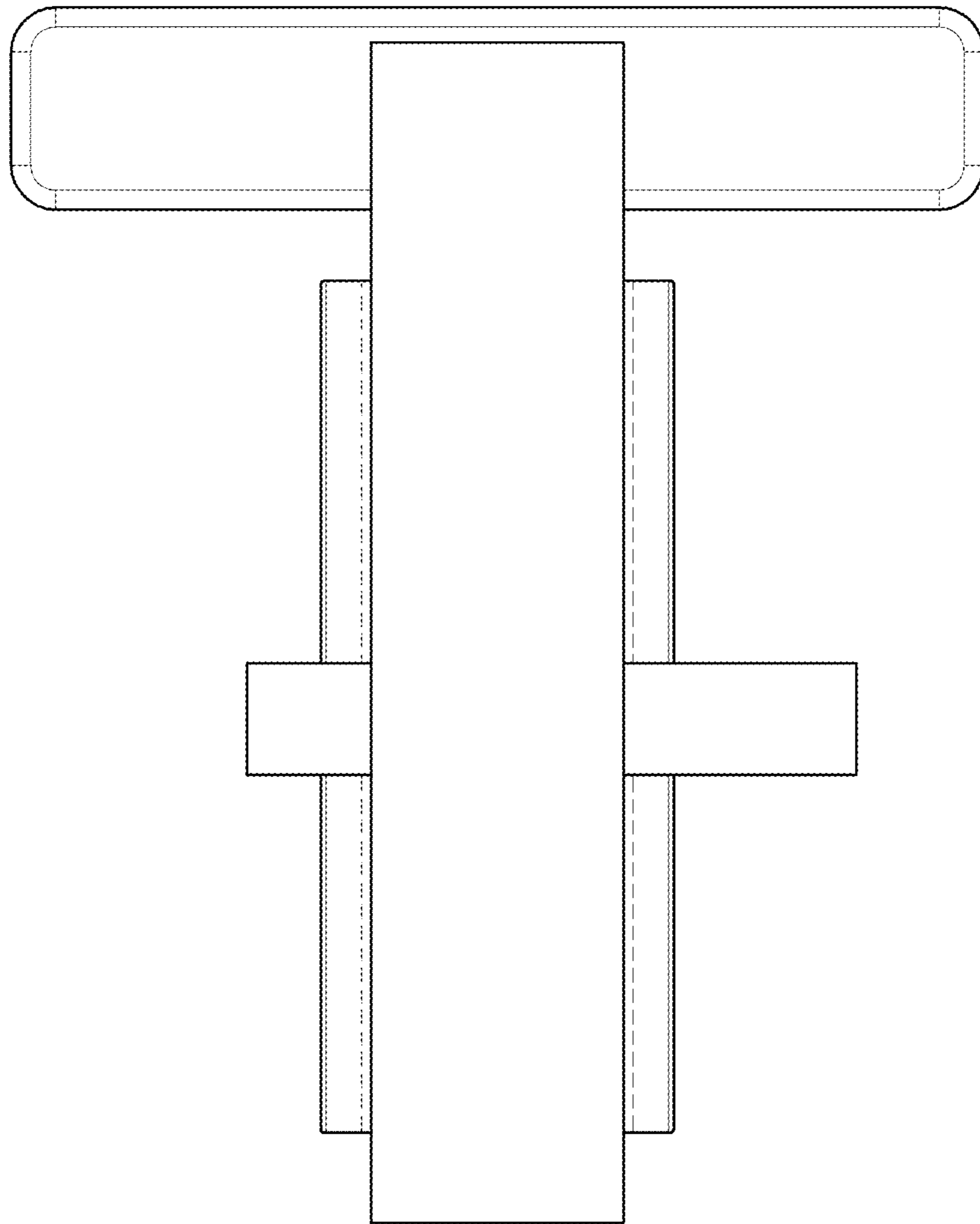

FIG. 15

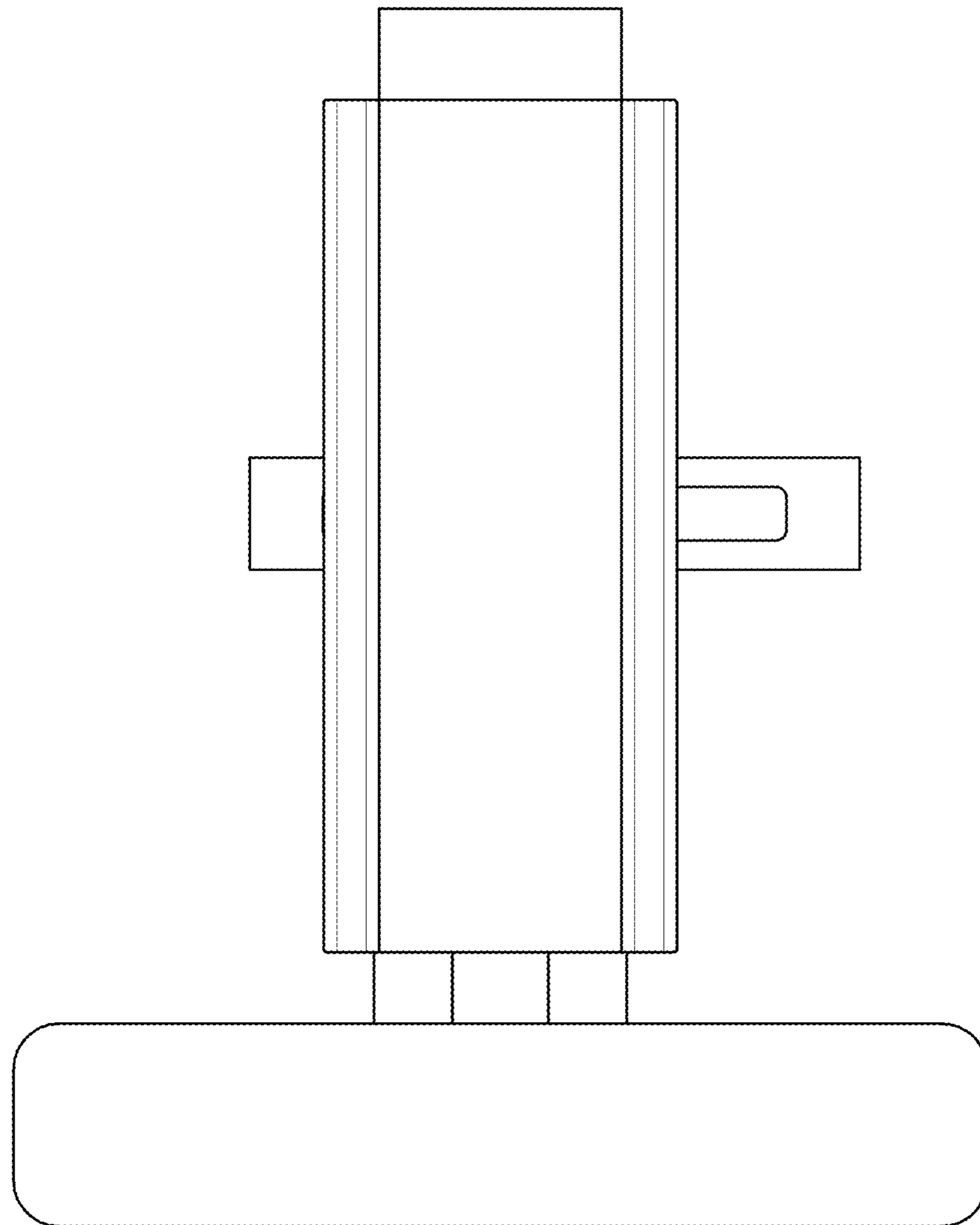

FIG. 16

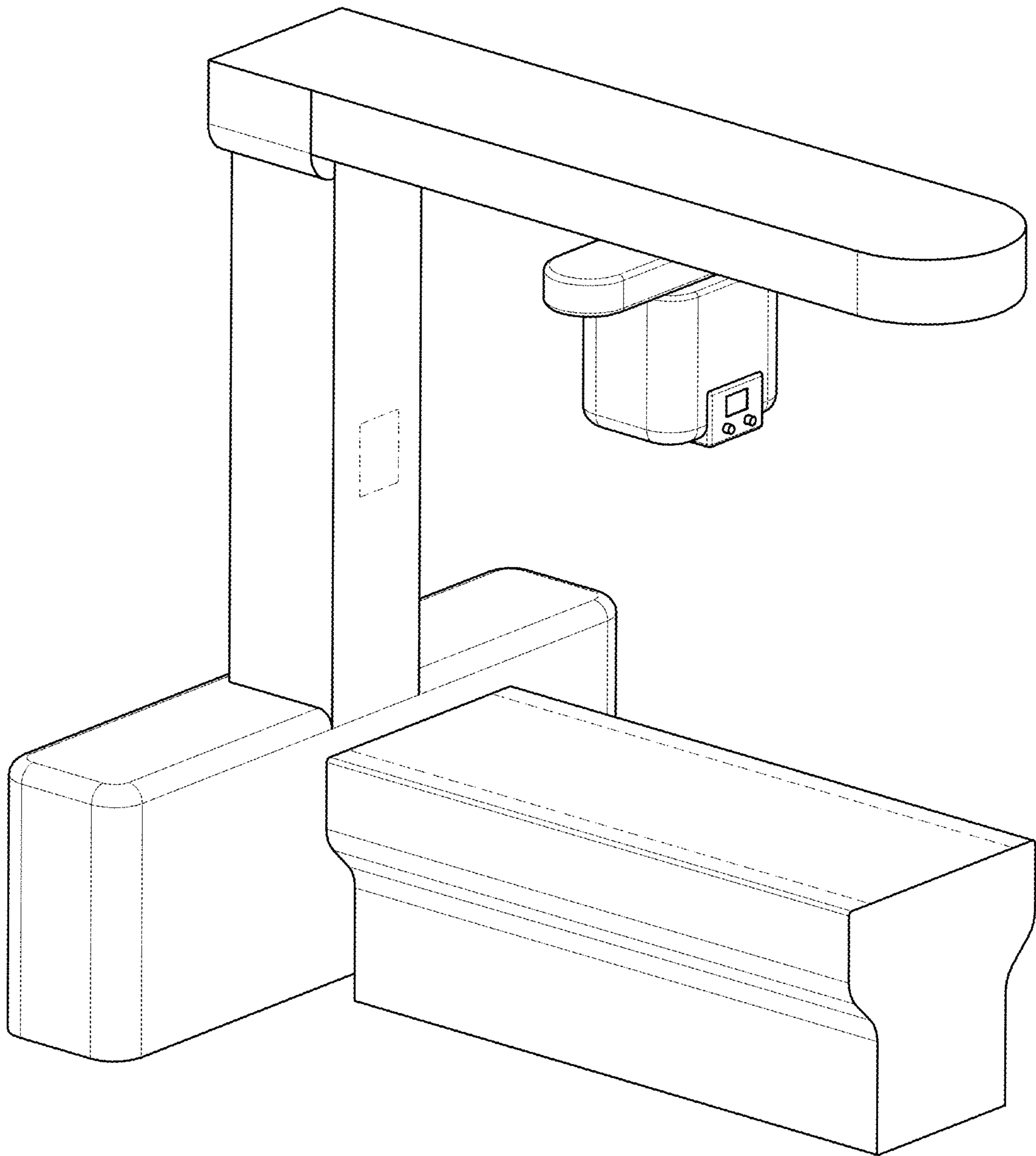

FIG. 17

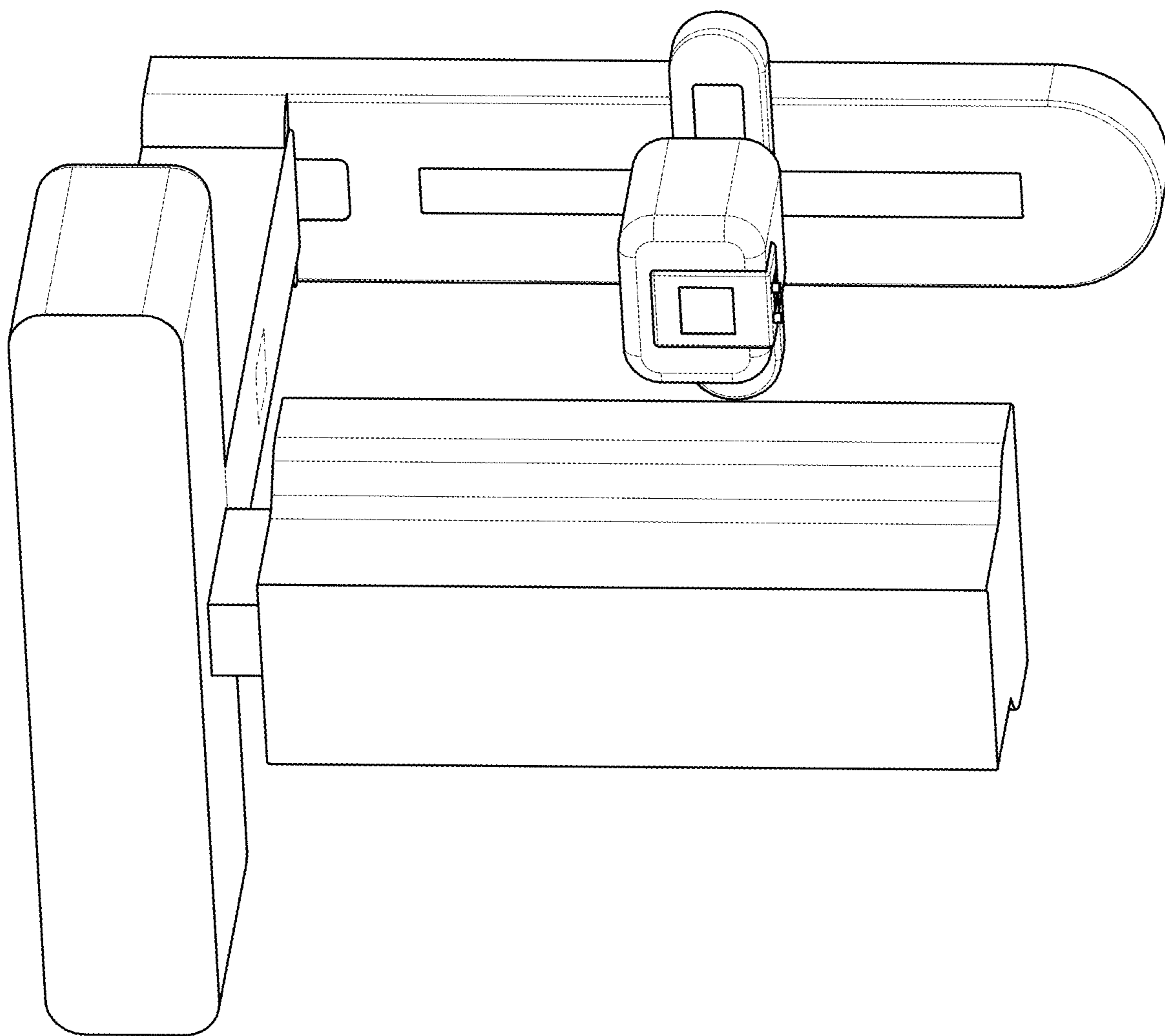

FIG. 18

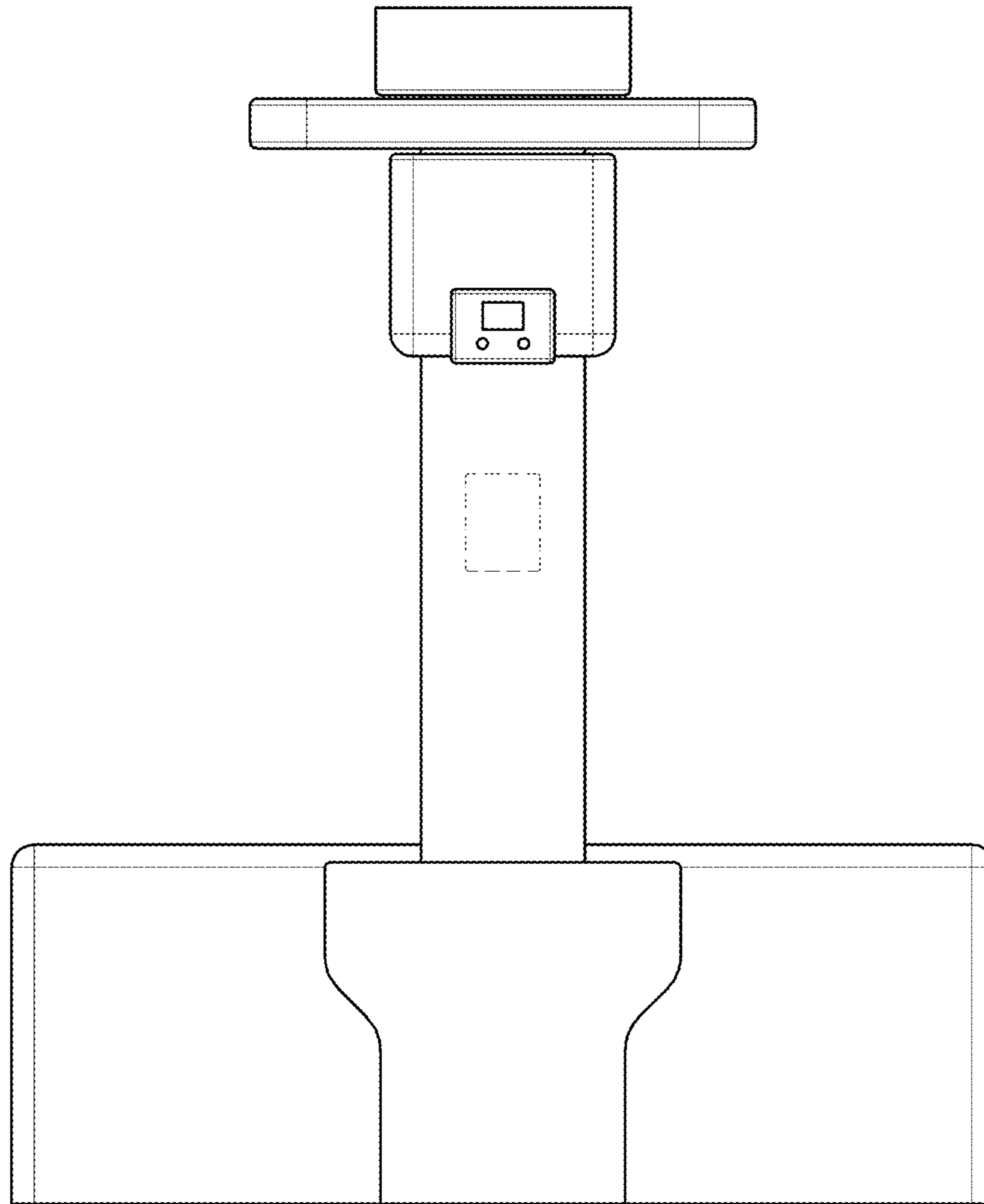

FIG. 19

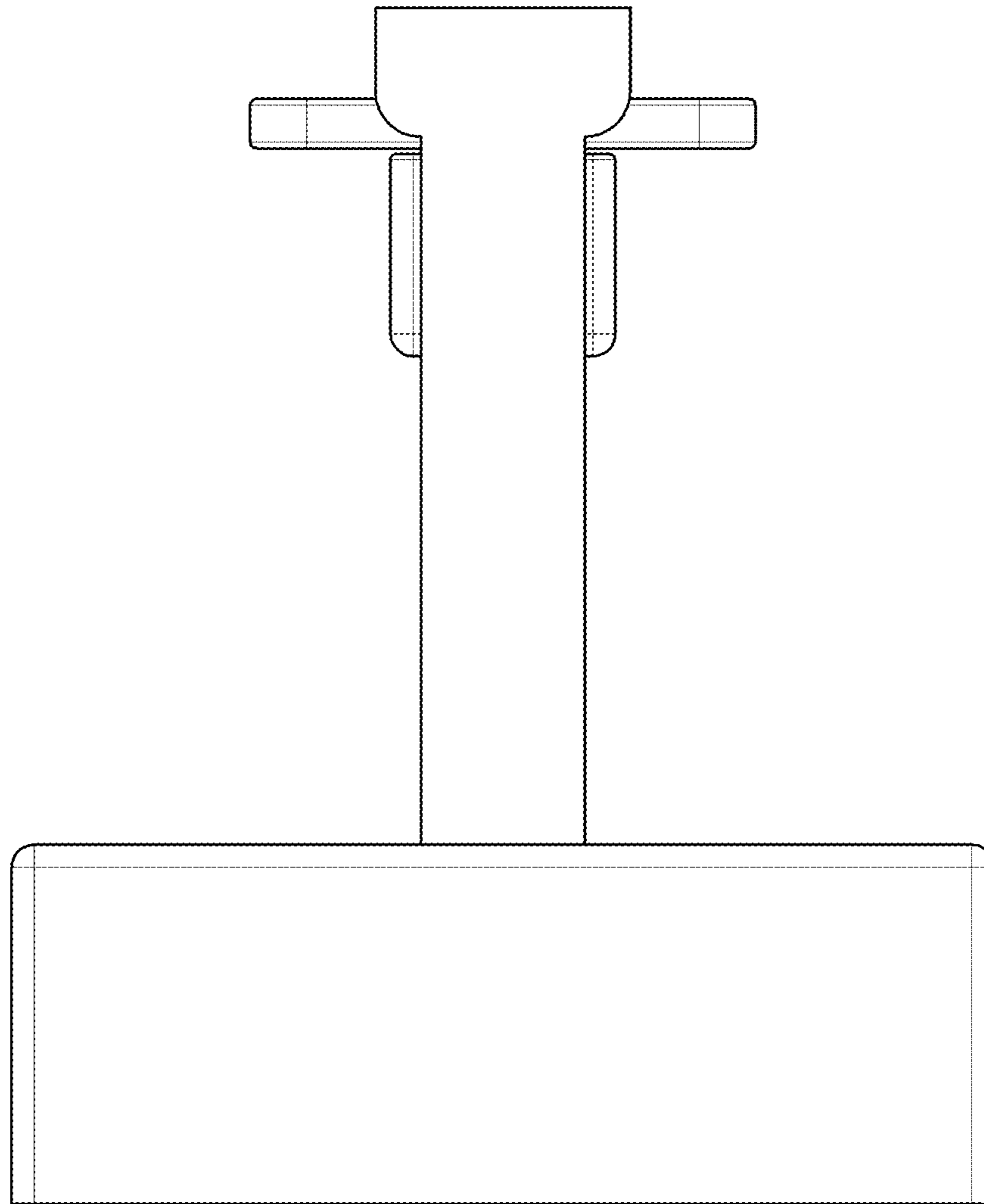

FIG. 20

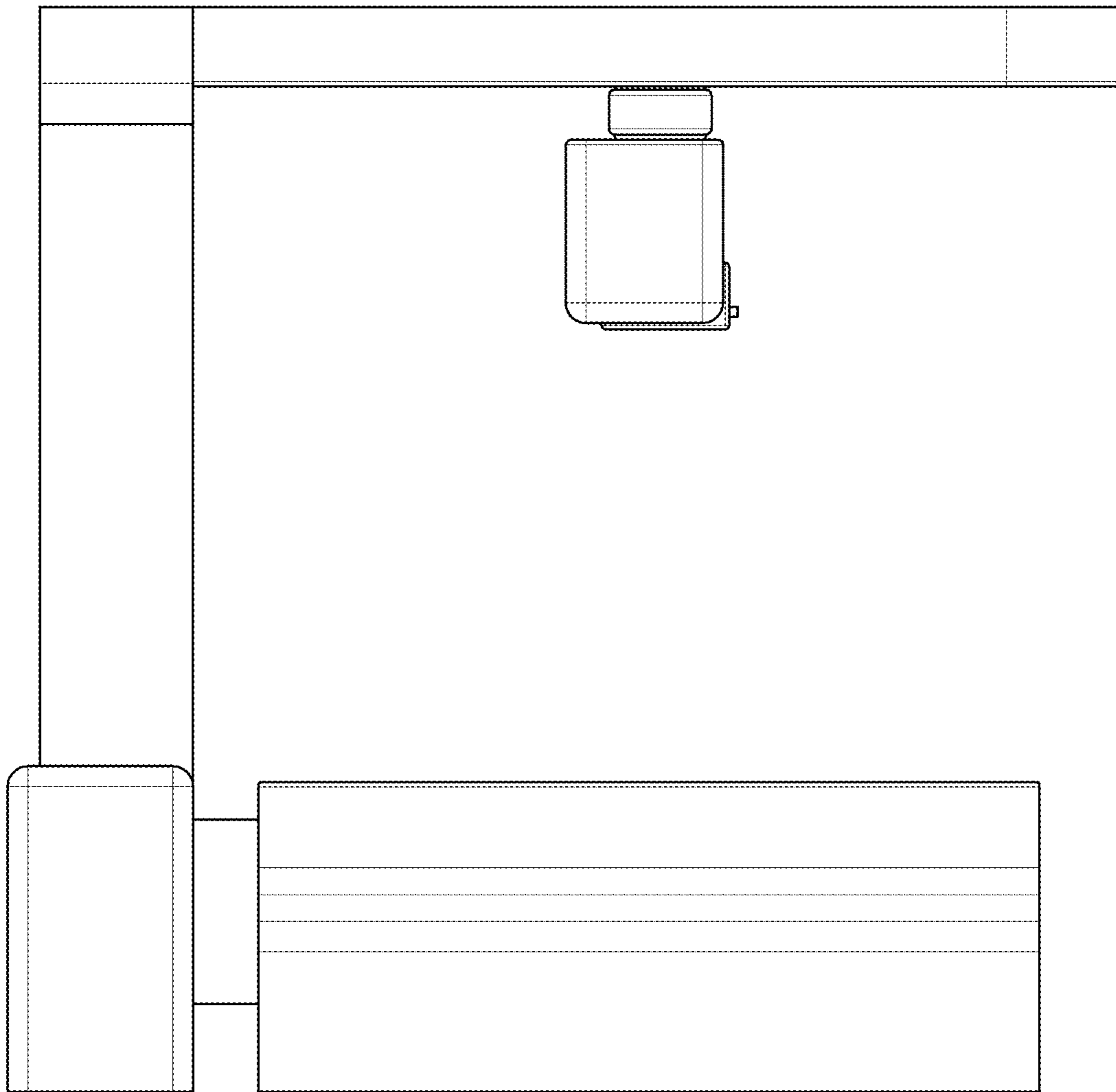

FIG. 21

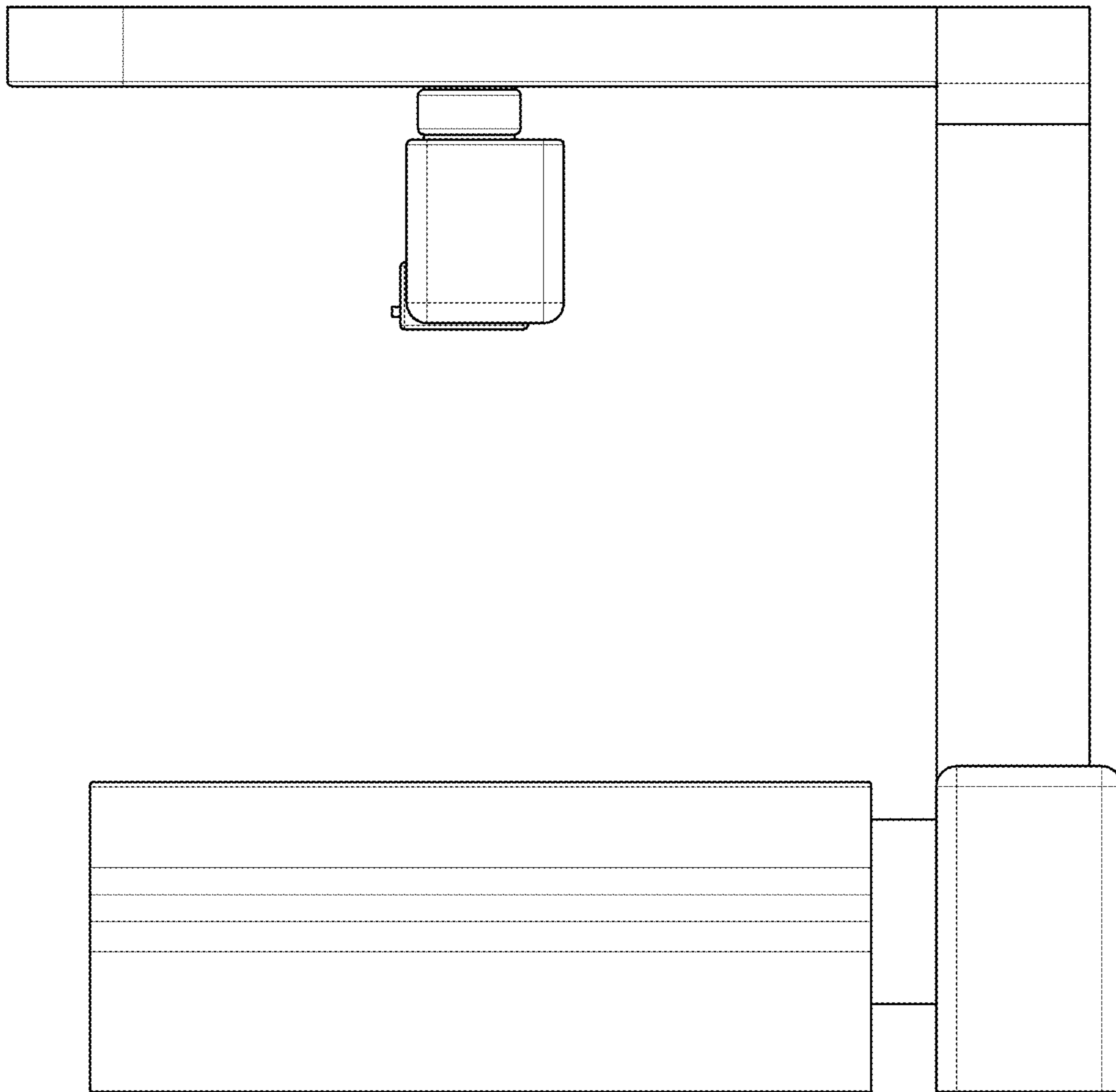

FIG. 22

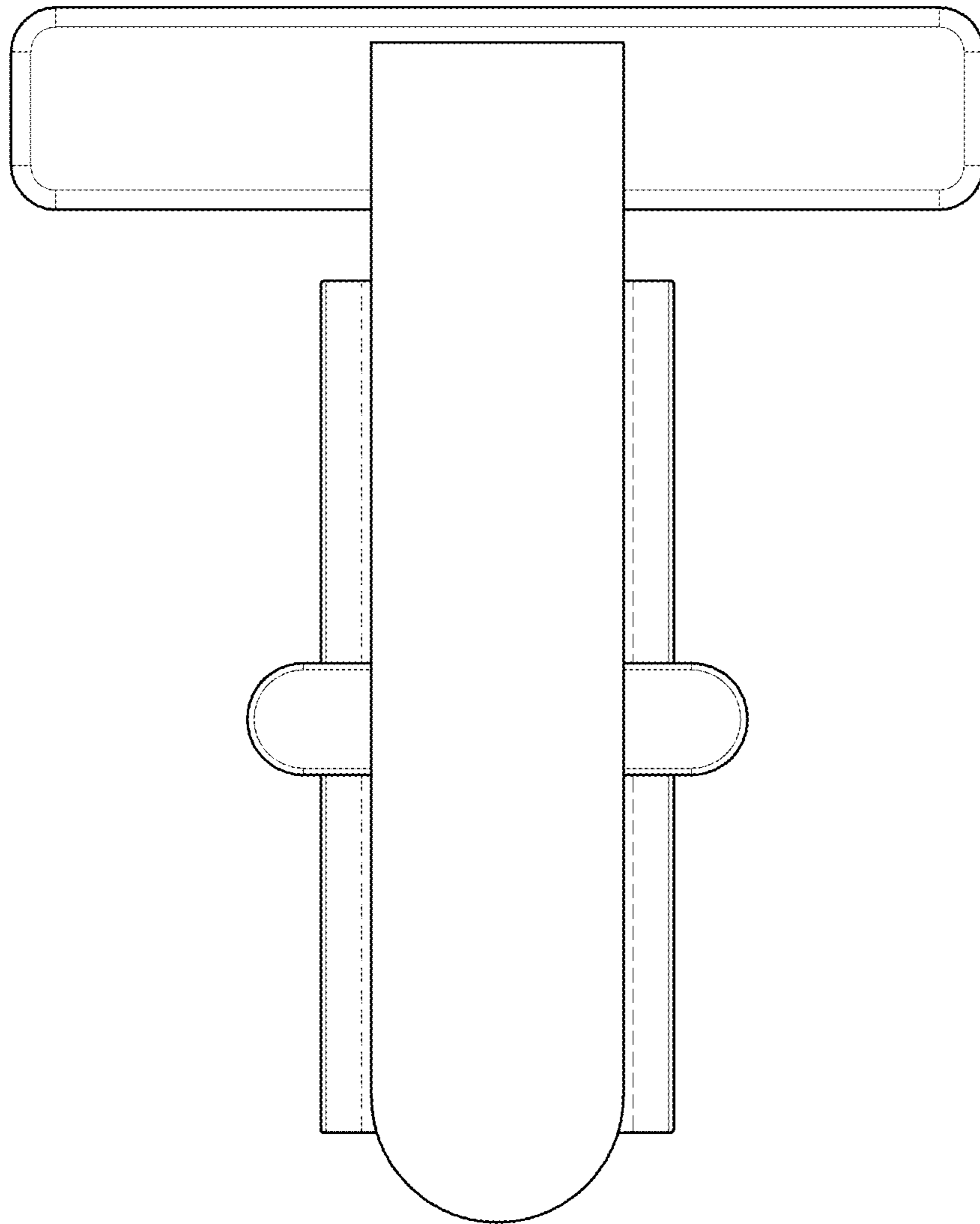

FIG. 23

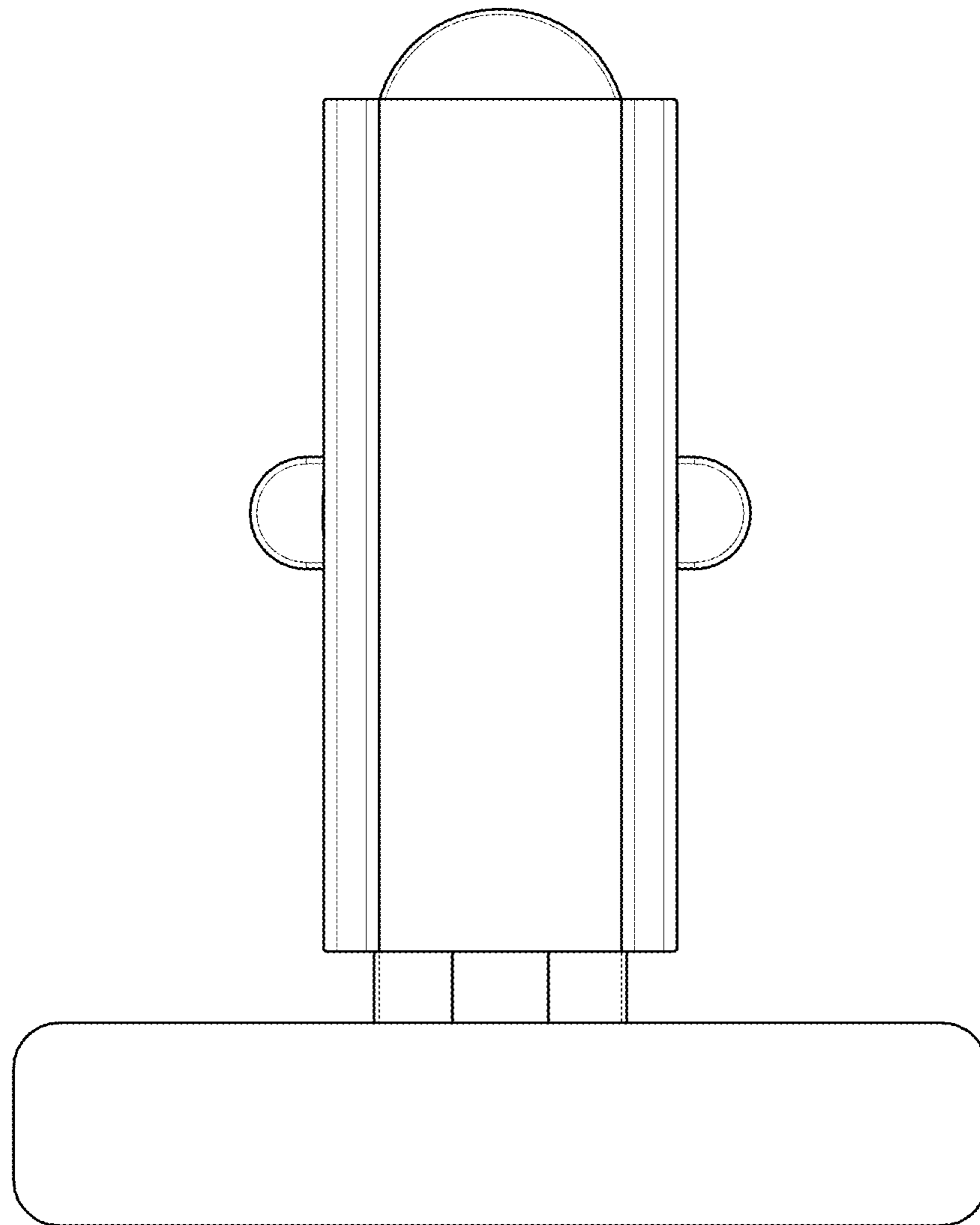

FIG. 24

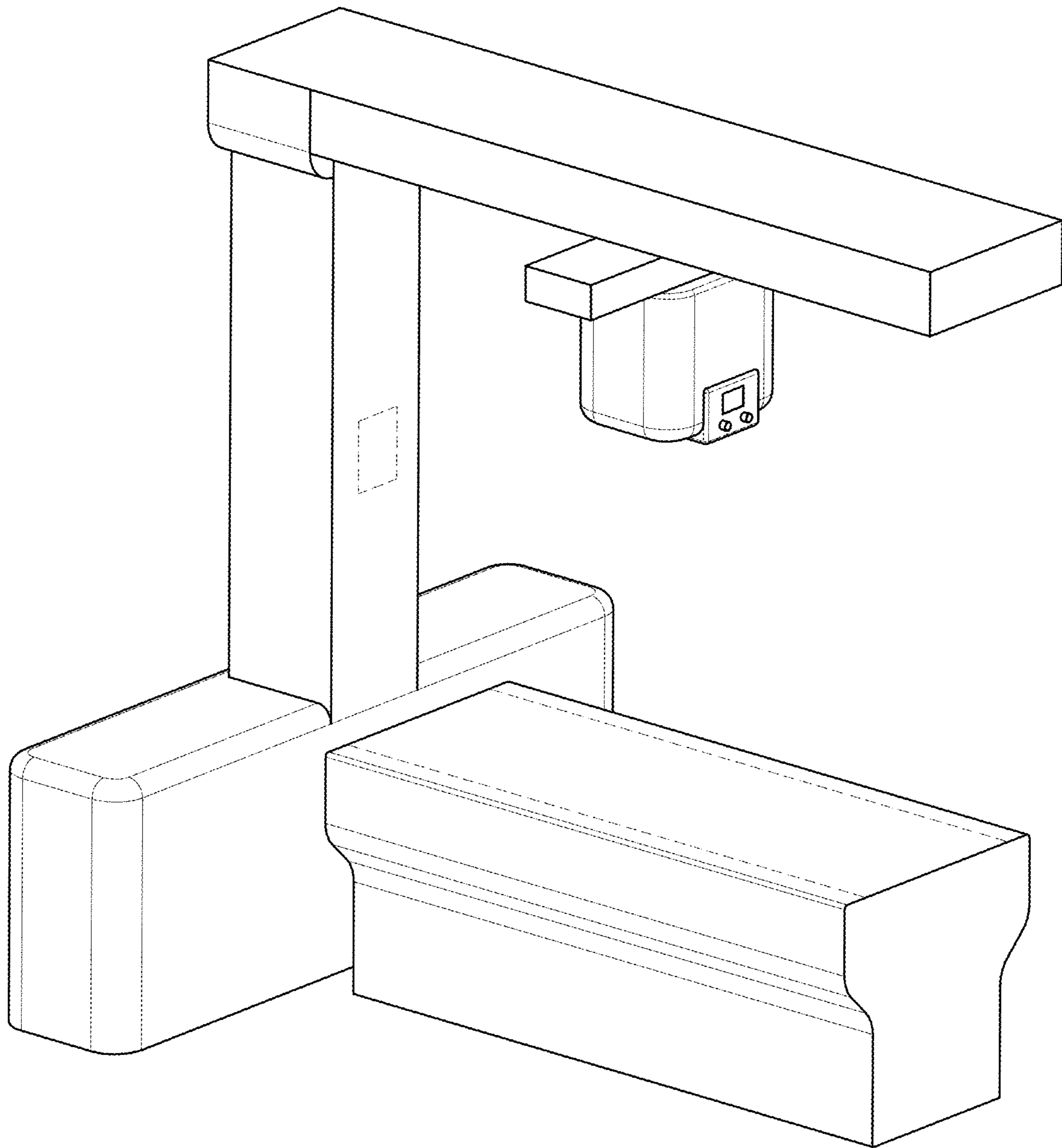

FIG. 25

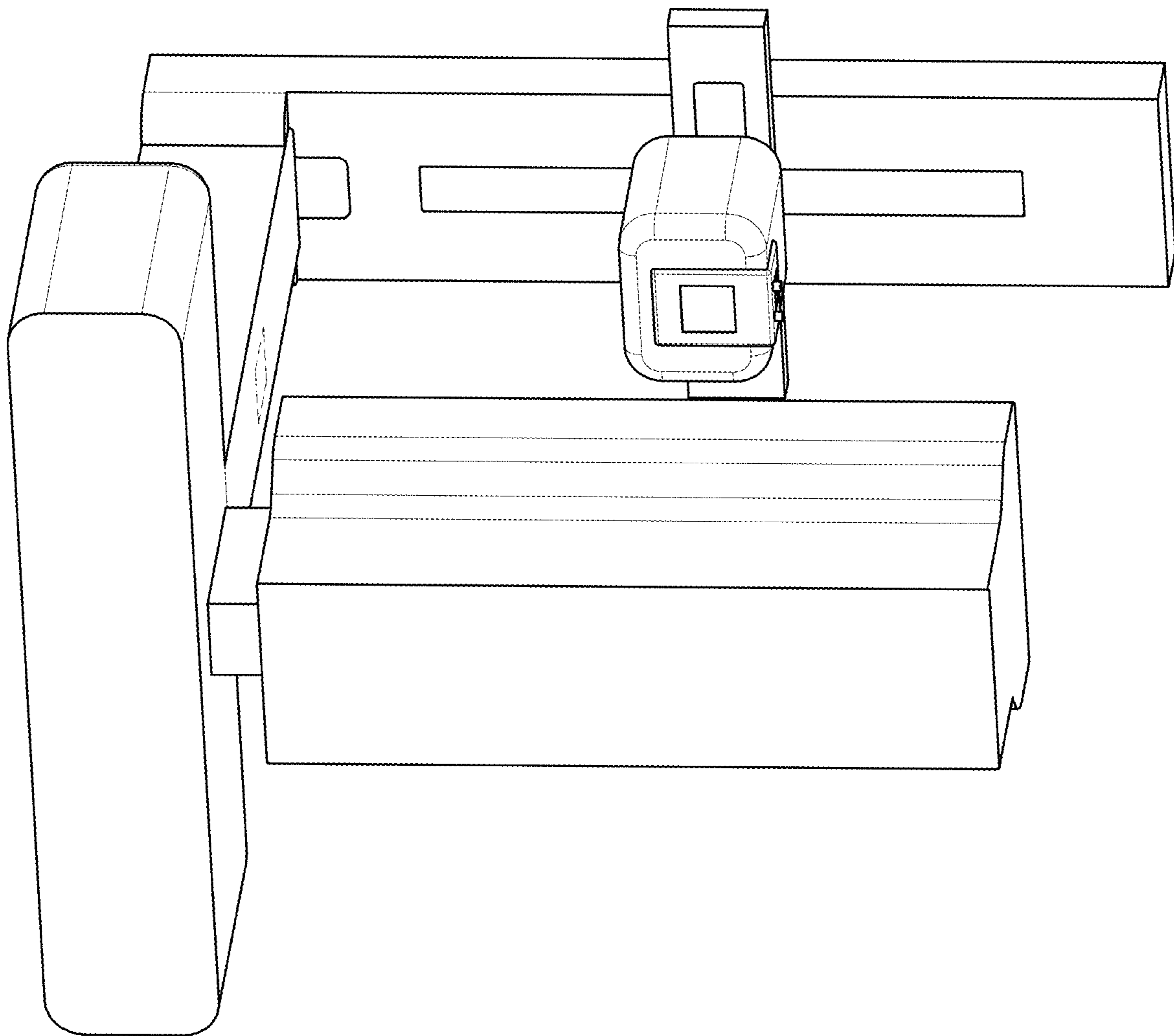

FIG. 26

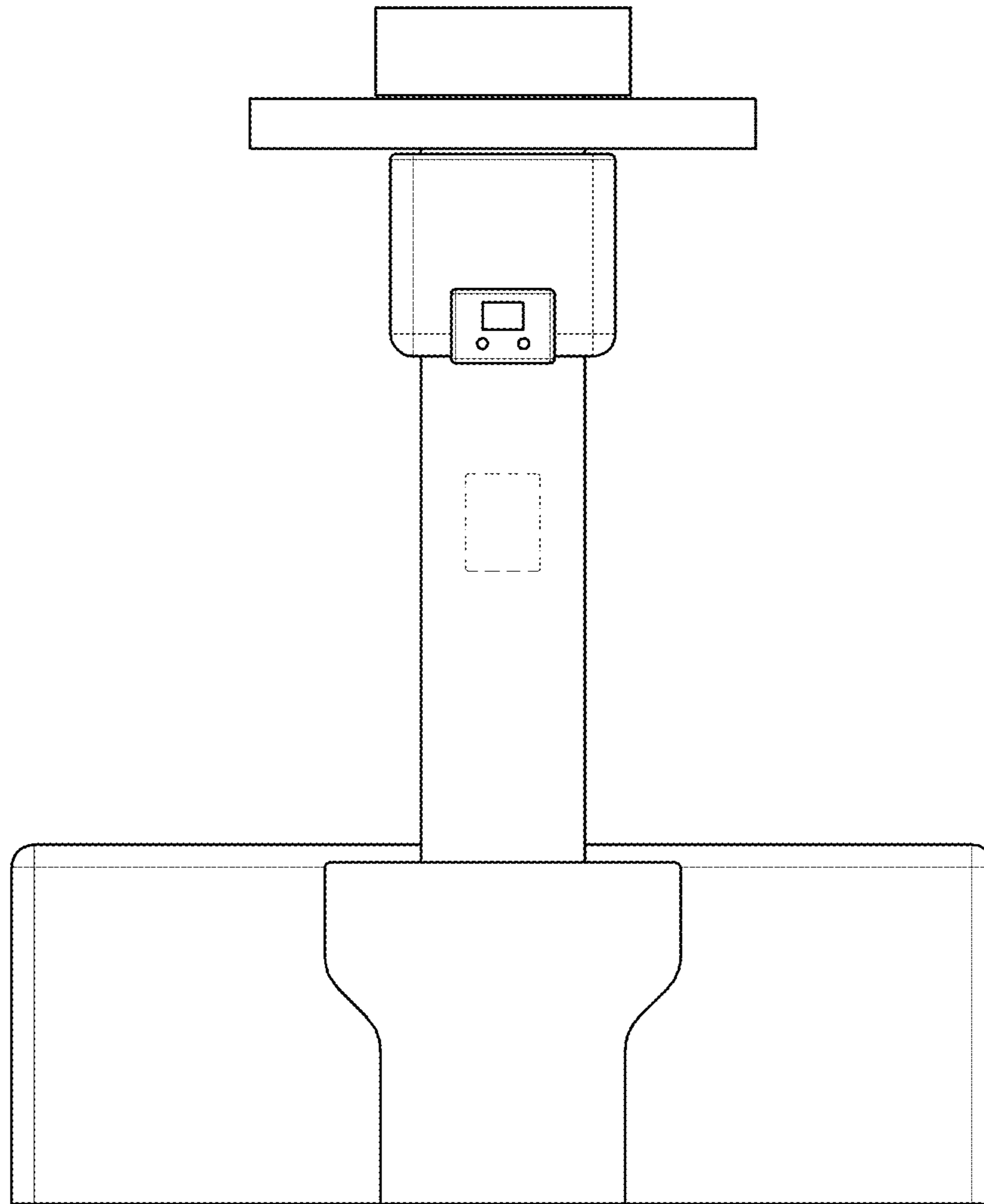

FIG. 27

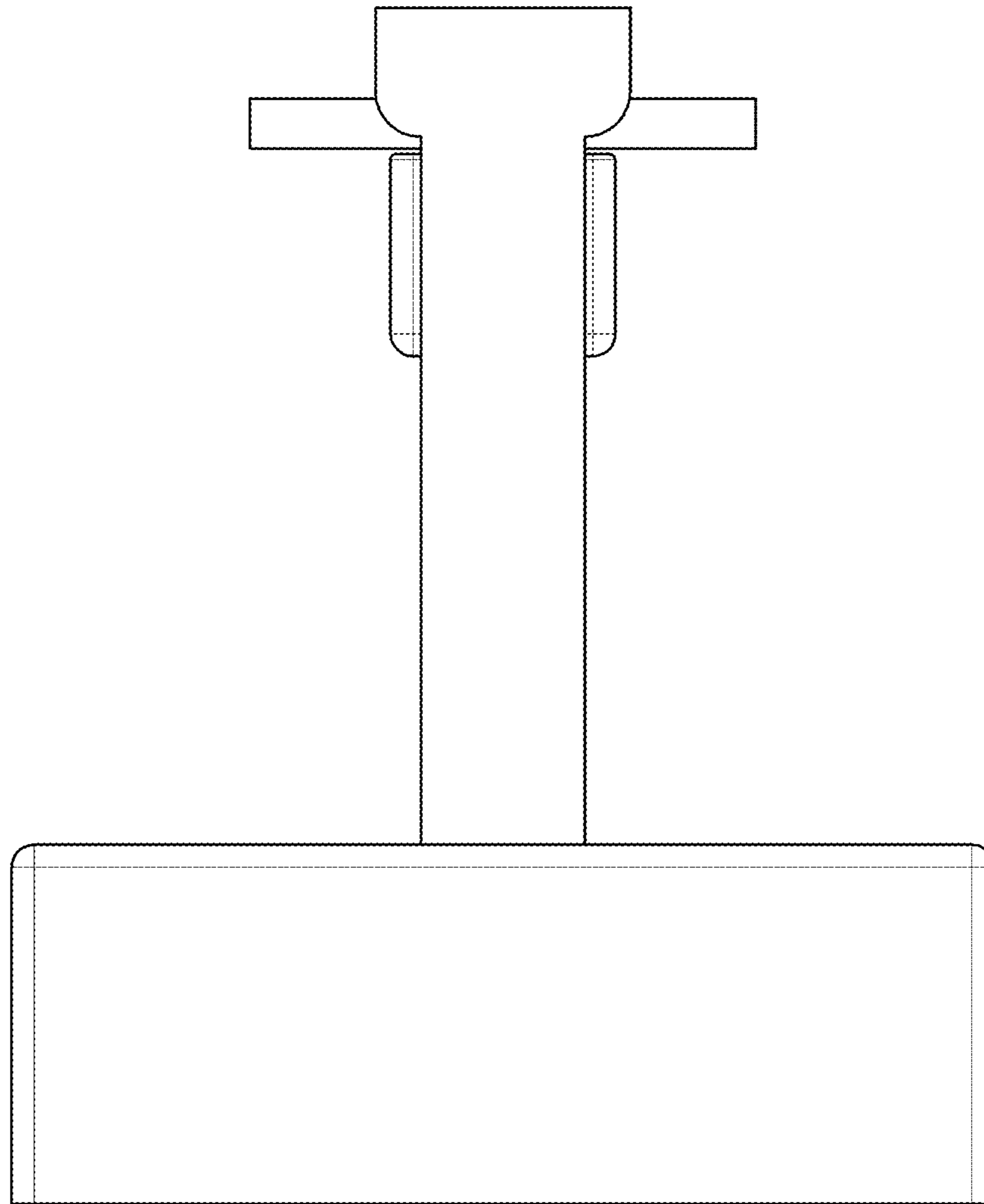

FIG. 28

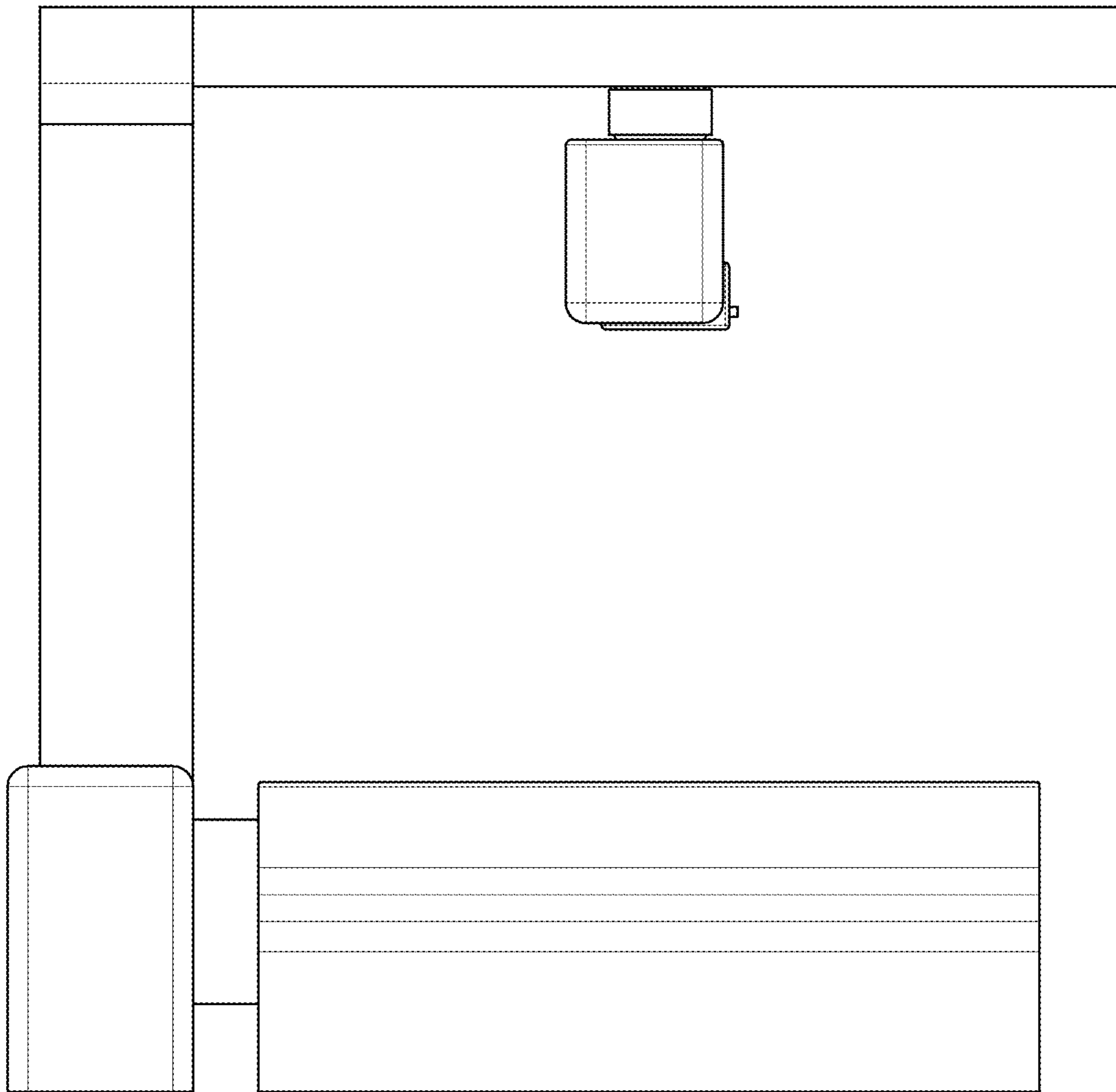

FIG. 29

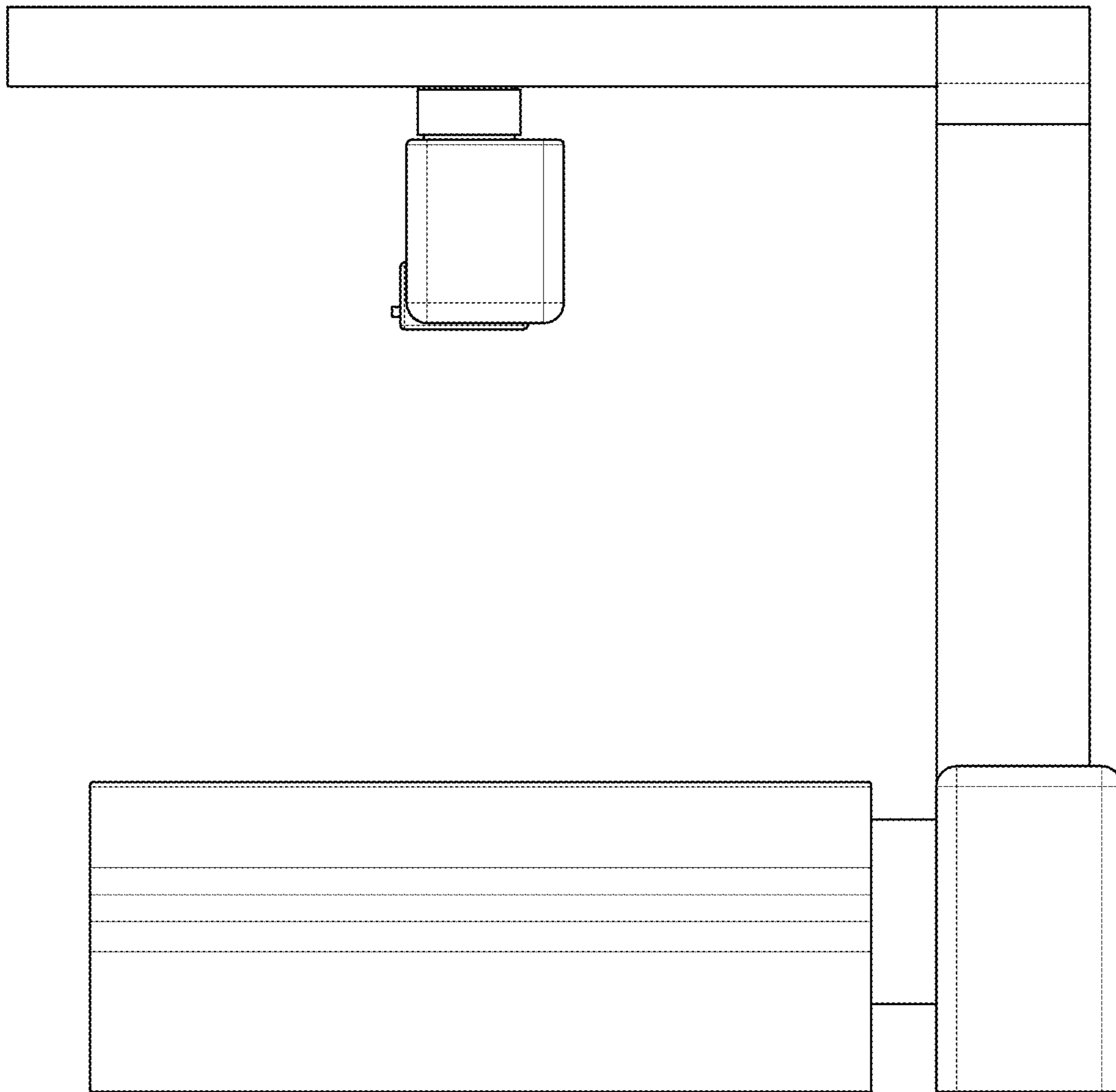

FIG. 30

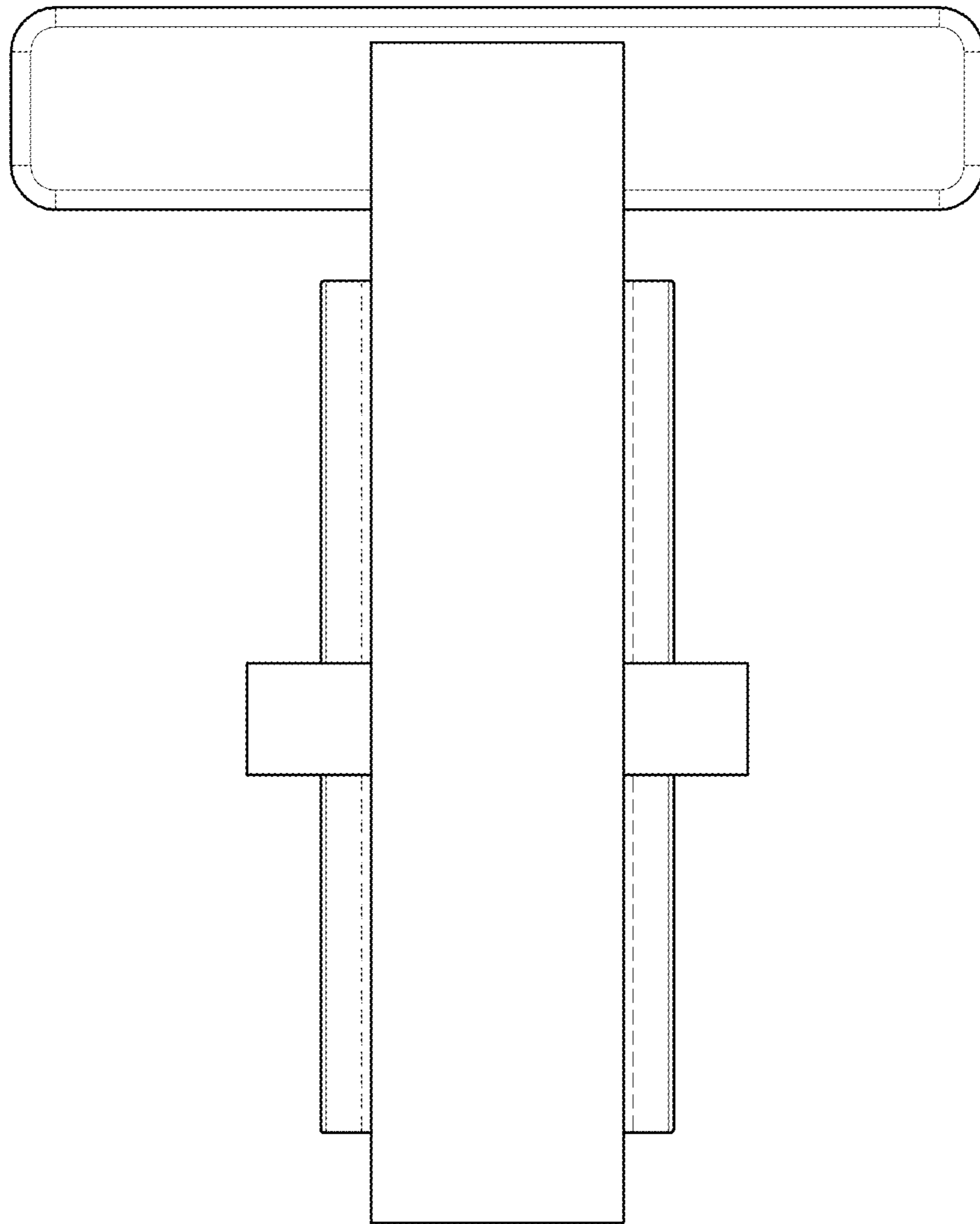

FIG. 31

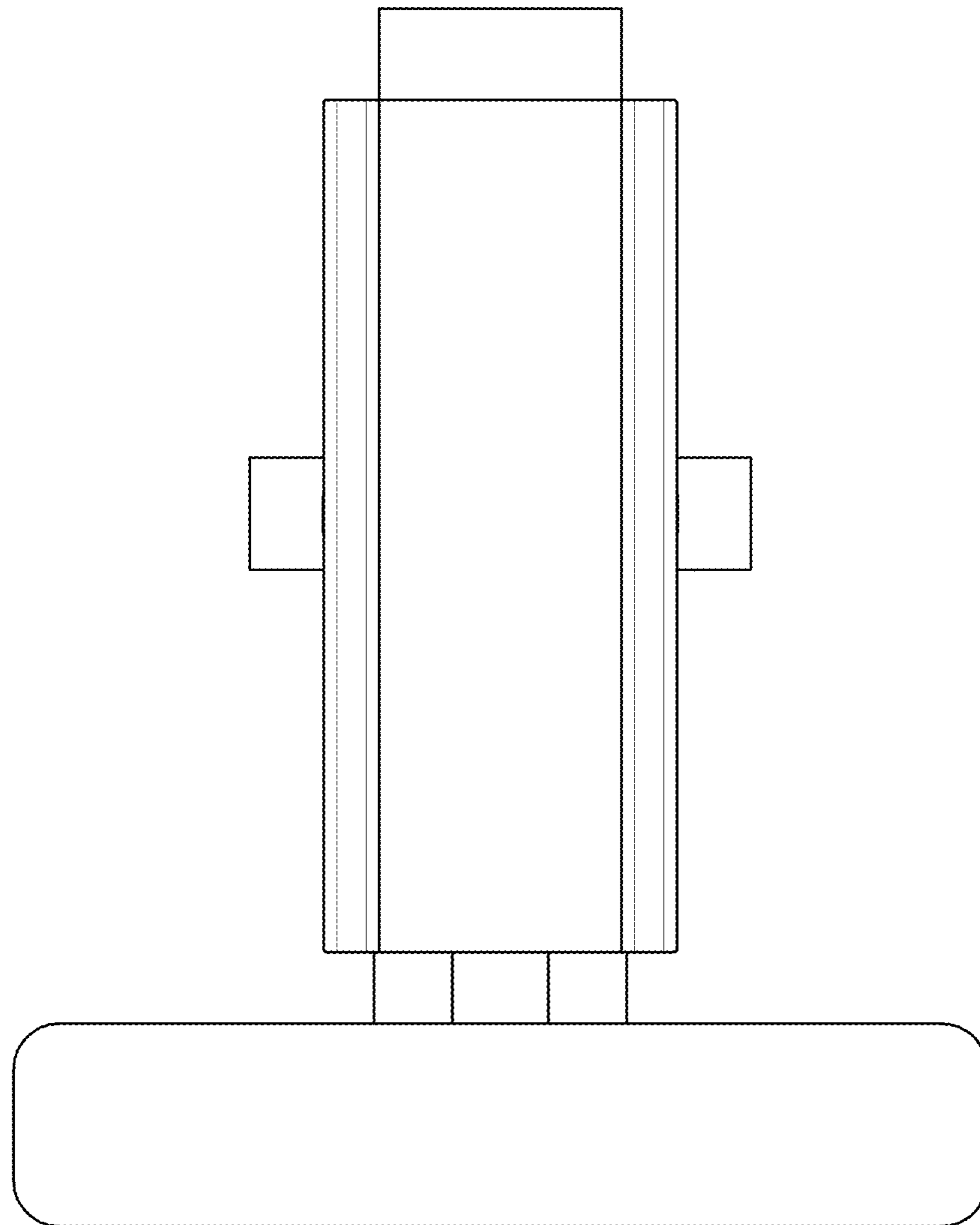

FIG. 32