

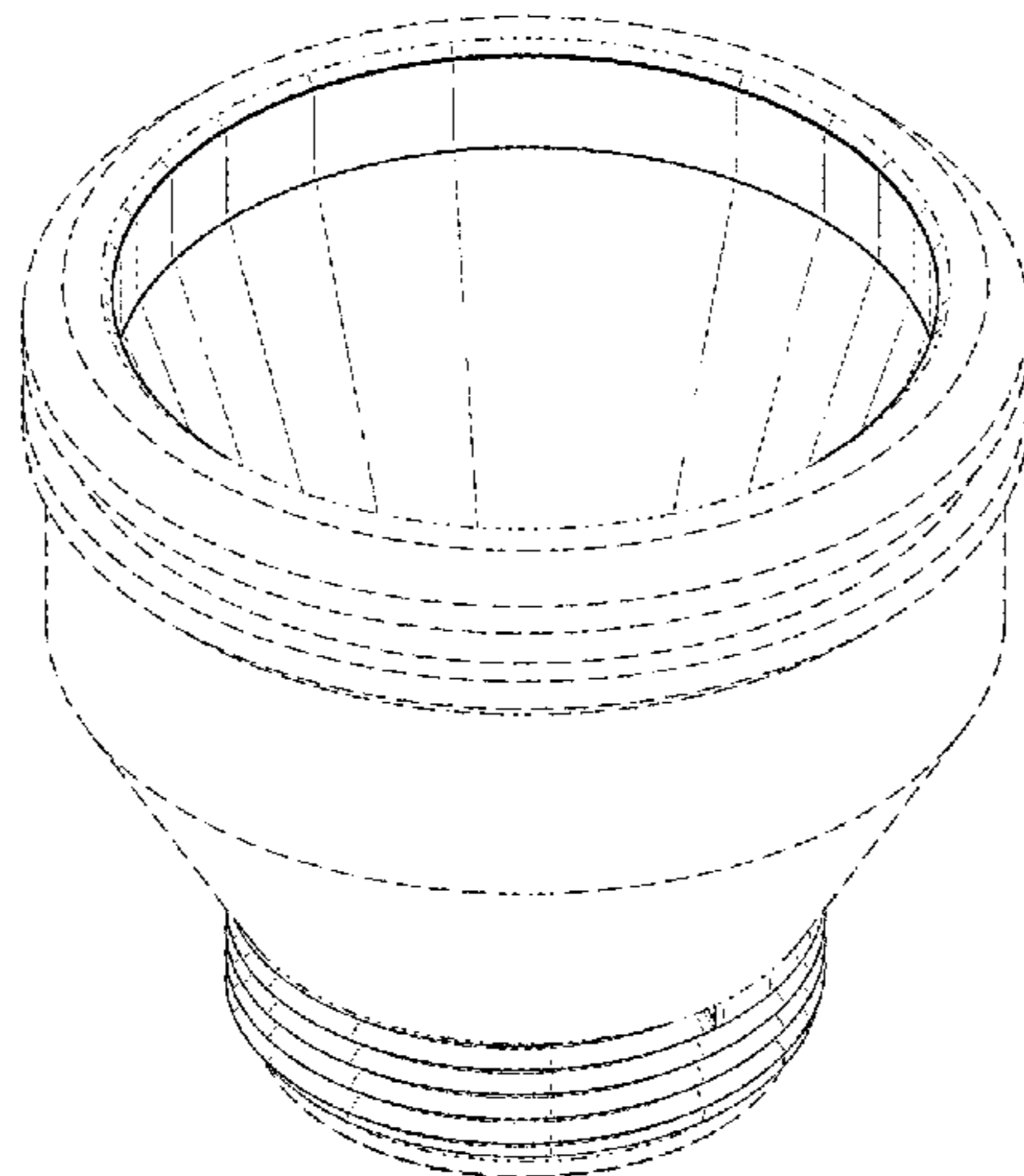

US00D981345S

(12) **United States Design Patent** (10) **Patent No.:** **US D981,345 S**
Eitschberger et al. (45) **Date of Patent:** **** Mar. 21, 2023**

- (54) **SHAPED CHARGE CASING** 2,889,775 A 6/1959 Owen
 2,946,283 A 7/1960 Udry
 (71) Applicant: **DynaEnergetics Europe GmbH,** 3,019,731 A 2/1962 David et al.
 Troisdorf (DE) 3,077,834 A 2/1963 Caldwell
 3,119,178 A 1/1964 Owen et al.
 (72) Inventors: **Christian Eitschberger,** Munich (DE); 3,170,400 A 2/1965 Nelson
Thilo Scharf, Letterkenny (IE) 3,246,707 A 4/1966 Bell
 3,255,659 A 6/1966 Venghiattis
 3,327,630 A 6/1967 Bell
 (73) Assignee: **DynaEnergetics Europe GmbH,** 3,374,735 A 3/1968 Moore
 Troisdorf (DE) 3,375,108 A 3/1968 Wyman et al.
 3,444,810 A 5/1969 Hakala
 (**) Term: **15 Years** 3,504,723 A 4/1970 Cushman et al.
 3,565,188 A 2/1971 Hakala
 3,589,453 A 6/1971 Venghiattis
 (21) Appl. No.: **29/758,155** 3,777,663 A 12/1973 Brown
 3,859,921 A 1/1975 Stephenson
 (22) Filed: **Nov. 12, 2020** 4,007,790 A 2/1977 Henning
 4,007,796 A 2/1977 Boop
 4,058,061 A 11/1977 Mansur, Jr. et al.
Related U.S. Application Data 4,099,464 A 7/1978 Cross et al.
 4,109,576 A 8/1978 Eckels
 (63) Continuation-in-part of application No. 4,140,188 A 2/1979 Vann
 PCT/EP2020/058241, filed on Mar. 24, 2020. 4,182,216 A 1/1980 DeCaro
 (51) **LOC (14) Cl.** **13-02** 4,266,613 A 5/1981 Boop
 (52) **U.S. Cl.** 4,273,047 A 6/1981 Rommer
 USPC **D13/118;** D22/199; D13/151 4,290,486 A 9/1981 Regalbuto
 (58) **Field of Classification Search** 4,491,185 A 1/1985 McClure
 USPC D13/101, 110, 118, 151, 184, 199; 4,496,008 A 1/1985 Pottier et al.
 D15/138, 139; D9/500, 502, 505; 4,499,830 A 2/1985 Majerus et al.
 D22/108, 109, 110, 111, 112; D23/259, 4,523,650 A 6/1985 Sehnert et al.
 D23/262, 266 4,574,892 A 3/1986 Grigar et al.
 CPC G01V 1/08; G01V 1/104; E21B 43/11; 4,598,775 A 7/1986 Vann et al.
 E21B 43/116; E21B 43/117; E21B 4,621,396 A 11/1986 Walker et al.
 43/119; E21B 43/1185; E21B 47/12; 4,650,009 A 3/1987 McClure et al.
 F24B 1/032 4,657,089 A 4/1987 Stout
 See application file for complete search history. 4,672,896 A * 6/1987 Precoul F42B 1/028
 102/476
 4,747,201 A 5/1988 Donovan et al.
 4,753,170 A 6/1988 Regalbuto et al.
 4,776,393 A 10/1988 Forehand et al.
 4,784,061 A 11/1988 Christopher
 (56) **References Cited** 4,790,383 A 12/1988 Savage et al.
 U.S. PATENT DOCUMENTS 4,800,815 A 1/1989 Appledorn et al.
 4,881,445 A * 11/1989 Hayes E21B 43/117
 102/306
 2,216,359 A 10/1940 Spencer 4,885,993 A 12/1989 Hancock et al.
 2,358,466 A 9/1944 Miller 4,889,183 A 12/1989 Sommers et al.
 2,418,486 A 4/1947 Smylie 5,027,708 A 7/1991 Gonzalez et al.
 2,598,651 A 5/1952 Spencer 5,052,489 A 10/1991 Carisella et al.
 2,734,456 A 2/1956 Sweetman 5,060,573 A 10/1991 Montgomery et al.
 RE24,127 E 3/1956 Binns et al. 5,088,413 A 2/1992 Huber
 2,756,958 A 7/1956 Binns et al. 5,088,557 A 2/1992 Ricles et al.
 2,785,631 A 3/1957 Blanchard



US D981,345 S

5,105,742 A	4/1992	Sumner		9,194,219 B1	11/2015	Hardesty et al.
5,159,145 A	10/1992	Carisella et al.		9,284,819 B2	3/2016	Tolman et al.
5,159,146 A	10/1992	Carisella et al.		9,291,039 B2	3/2016	King et al.
5,322,019 A	6/1994	Hyland		9,360,222 B1	6/2016	Collier
5,392,860 A	2/1995	Ross		9,428,979 B2	8/2016	Bell et al.
5,436,791 A	7/1995	Turano et al.		9,476,289 B2	10/2016	Wells
5,505,135 A *	4/1996	Fritz	F42B 3/28	9,494,021 B2	11/2016	Parks et al.
			102/307	9,562,421 B2	2/2017	Hardesty et al.
5,509,356 A	4/1996	Renfro		9,581,422 B2	2/2017	Preiss et al.
5,567,906 A	10/1996	Reese et al.		9,598,942 B2	3/2017	Wells et al.
5,603,384 A	2/1997	Bethel et al.		9,605,937 B2	3/2017	Eitschberger et al.
D378,847 S *	4/1997	Ey	D22/115	9,612,095 B2	4/2017	Smart et al.
5,703,319 A	12/1997	Fritz et al.		9,671,201 B2	6/2017	Marya et al.
5,775,426 A	7/1998	Snider et al.		9,677,363 B2	6/2017	Schacherer et al.
5,792,977 A	8/1998	Chawla		9,784,549 B2	10/2017	Eitschberger
5,816,343 A	10/1998	Markel et al.		9,845,666 B2	12/2017	Hardesty et al.
5,992,289 A	11/1999	George et al.		9,862,027 B1	1/2018	Loehken
6,006,833 A	12/1999	Burleson et al.		9,903,192 B2	2/2018	Entchev et al.
6,012,525 A	1/2000	Burleson et al.		9,921,038 B2	3/2018	Weinhold
6,098,707 A	8/2000	Pastusek et al.		10,047,591 B2	8/2018	Bell et al.
6,112,666 A	9/2000	Murray et al.		10,066,921 B2	9/2018	Eitschberger
6,298,915 B1	10/2001	George		10,077,641 B2	9/2018	Rogman et al.
6,305,287 B1	10/2001	Capers et al.		10,138,713 B2	11/2018	Tolman et al.
6,349,649 B1	2/2002	Jacoby et al.		10,151,180 B2	12/2018	Robey et al.
6,354,374 B1	3/2002	Edwards et al.		10,188,990 B2	1/2019	Burmeister et al.
6,418,853 B1	7/2002	Duguet et al.		10,190,398 B2	1/2019	Goodman et al.
6,453,817 B1 *	9/2002	Markel	F42B 3/08	10,240,441 B2	3/2019	Geerts et al.
			102/306	10,267,127 B2	4/2019	Geerts et al.
6,520,258 B1	2/2003	Yang et al.		10,376,955 B2	8/2019	Loehken
6,619,176 B2	9/2003	Renfro et al.		10,458,213 B1	10/2019	Eitschberger et al.
6,651,747 B2	11/2003	Chen et al.		10,584,565 B2	3/2020	Golian et al.
6,668,726 B2	12/2003	Lussier		10,683,735 B1	6/2020	McCarthy et al.
6,684,791 B1	2/2004	Barnhart		10,739,115 B2	8/2020	Loehken et al.
6,739,265 B1	5/2004	Badger et al.		D900,036 S *	10/2020	Wuester D13/151
6,742,602 B2	6/2004	Trotechaud		10,954,760 B2	3/2021	Mcnelis et al.
6,752,083 B1	6/2004	Lerche et al.		2002/0017214 A1	2/2002	Jacoby et al.
6,843,317 B2	1/2005	Mackenzie		2002/0020320 A1	2/2002	Lebaudy et al.
7,011,027 B2	3/2006	Reese et al.		2002/0062991 A1	5/2002	Farrant et al.
7,107,908 B2	9/2006	Forman et al.		2002/0189482 A1	12/2002	Kneisl et al.
7,193,527 B2	3/2007	Hall		2003/0000411 A1	1/2003	Cernocky et al.
7,237,486 B2	7/2007	Myers, Jr. et al.		2003/0001753 A1	1/2003	Cernocky et al.
7,278,491 B2	10/2007	Scott		2005/0115448 A1	6/2005	Pratt et al.
7,364,451 B2	4/2008	Ring et al.		2005/0178282 A1	8/2005	Brooks et al.
7,568,429 B2	8/2009	Hummel et al.		2005/0186823 A1	8/2005	Ring et al.
7,690,306 B1	4/2010	King		2005/0194146 A1	9/2005	Barker et al.
7,721,649 B2	5/2010	Hetz et al.		2005/0229805 A1	10/2005	Myers, Jr. et al.
7,762,172 B2	7/2010	Li et al.		2007/0084336 A1	4/2007	Neves
7,778,006 B2	8/2010	Stewart et al.		2007/0125540 A1	6/2007	Gerez et al.
7,810,430 B2	10/2010	Chan et al.		2007/0158071 A1	7/2007	Mooney, Jr. et al.
7,819,064 B2	10/2010	Saenger et al.		2008/0047456 A1	2/2008	Li et al.
7,901,247 B2	3/2011	Ring		2008/0110612 A1	5/2008	Prinz et al.
7,908,970 B1	3/2011	Jakaboski et al.		2008/0134922 A1	6/2008	Grattan et al.
7,929,270 B2	4/2011	Hummel et al.		2008/0149338 A1	6/2008	Goodman et al.
D637,492 S *	5/2011	Baird	D24/224	2008/0173204 A1	7/2008	Anderson et al.
D642,060 S *	7/2011	Leclair	D9/520	2008/0264639 A1	10/2008	Parrott et al.
8,066,083 B2	11/2011	Hales et al.		2009/0050322 A1	2/2009	Hill et al.
8,069,789 B2	12/2011	Hummel et al.		2009/0272529 A1	11/2009	Crawford
8,157,022 B2	4/2012	Bertoja et al.		2010/0000789 A1	1/2010	Barton et al.
8,181,718 B2	5/2012	Burleson et al.		2010/0089643 A1	4/2010	Vidal
8,182,212 B2	5/2012	Parcell		2010/0163224 A1	7/2010	Strickland
8,186,259 B2	5/2012	Burleson et al.		2010/0230104 A1	9/2010	Nölke et al.
8,220,394 B2	7/2012	Bates et al.		2011/0024116 A1	2/2011	McCann et al.
8,256,337 B2	9/2012	Hill		2011/0094406 A1	4/2011	Marya et al.
8,322,284 B2	12/2012	Meddes et al.		2012/0085538 A1	4/2012	Guerrero et al.
8,342,094 B2	1/2013	Marya et al.		2012/0199031 A1	8/2012	Lanclos
8,395,878 B2	3/2013	Stewart et al.		2012/0199352 A1	8/2012	Lanclos et al.
8,451,137 B2	5/2013	Bonavides et al.		2012/0241169 A1	9/2012	Hales et al.
8,544,563 B2	10/2013	Bourne et al.		2012/0242135 A1	9/2012	Thomson et al.
8,584,772 B2	11/2013	Yang et al.		2012/0247769 A1	10/2012	Schacherer et al.
8,661,978 B2	3/2014	Backhus et al.		2012/0247771 A1	10/2012	Black et al.
8,695,506 B2	4/2014	Lanclos		2012/0298361 A1	11/2012	Sampson
8,863,665 B2	10/2014	DeVries et al.		2013/0008639 A1	1/2013	Tassaroli et al.
8,875,787 B2	11/2014	Tassaroli		2013/0056208 A1	3/2013	Xu
8,881,816 B2	11/2014	Glenn et al.		2013/0062055 A1	3/2013	Tolman et al.
9,038,521 B1	5/2015	Rollins et al.		2013/0118342 A1	5/2013	Tassaroli
9,045,692 B2	6/2015	Lumley		2013/0199843 A1	8/2013	Ross
9,080,432 B2	7/2015	Yang et al.		2013/0248174 A1	9/2013	Dale et al.
9,080,433 B2	7/2015	Lanclos et al.		2013/0327571 A1	12/2013	Andrzejak
9,181,790 B2	11/2015	Mace et al.		2014/0131035 A1	5/2014	Entchev et al.

US D981,345 S

2015/0176386	A1	6/2015	Castillo et al.	
2015/0226043	A1*	8/2015	Hardesty	E21B 43/117 166/55
2015/0226044	A1	8/2015	Ursi et al.	
2015/0316360	A1*	11/2015	Hinton	E21B 43/117 102/307
2015/0330192	A1	11/2015	Rogman et al.	
2016/0040520	A1	2/2016	Tolman et al.	
2016/0061572	A1	3/2016	Eitschberger et al.	
2016/0069163	A1	3/2016	Tolman et al.	
2016/0168961	A1	6/2016	Parks et al.	
2016/0169639	A1	6/2016	Smart et al.	
2017/0030693	A1	2/2017	Preiss et al.	
2017/0052004	A1	2/2017	Xue	
2017/0058648	A1	3/2017	Geerts et al.	
2017/0145798	A1	5/2017	Robey et al.	
2017/0211363	A1	7/2017	Bradley et al.	
2017/0241244	A1	8/2017	Barker et al.	
2017/0268860	A1	9/2017	Eitschberger	
2017/0314372	A1	11/2017	Tolman et al.	
2018/0030334	A1	2/2018	Collier et al.	
2018/0087353	A1	3/2018	Skyler	
2018/0135398	A1	5/2018	Entchev et al.	
2018/0209251	A1	7/2018	Robey et al.	
2018/0216446	A1*	8/2018	Allison	E21B 43/26
2018/0274342	A1	9/2018	Sites	
2018/0299239	A1	10/2018	Eitschberger et al.	
2018/0318770	A1	11/2018	Eitschberger et al.	
2019/0040722	A1	2/2019	Yang et al.	
2019/0048693	A1	2/2019	Henke et al.	
2019/0049225	A1	2/2019	Eitschberger	
2019/0195054	A1	6/2019	Bradley et al.	
2019/0211655	A1	7/2019	Bradley et al.	
2019/0284889	A1	9/2019	LaGrange et al.	
2019/0292887	A1	9/2019	Austin, II et al.	
2019/0316449	A1	10/2019	Schultz et al.	
2020/0217629	A1	7/2020	Loehken et al.	
2021/0301632	A1	9/2021	Loehken et al.	
2022/0178230	A1	6/2022	Eitschberger et al.	

FOREIGN PATENT DOCUMENTS

CA	2821506	A1	1/2015
CA	3048505	A1	7/2018
CA	3101558	A1	12/2019
CN	85107897	A	9/1986
CN	101300403	A	11/2008
CN	101397890	A	4/2009
CN	201620848	U	11/2010
CN	202810806	U	3/2013
CN	105377479	A	3/2016
CN	210598934	U	5/2020
DE	19630339	A1	1/1997
EP	0538135	B1	5/1997
EP	1345003	A2	9/2003
EP	1317650	B1	5/2006
EP	2282003	A2	2/2011
EP	2598830	A1	6/2013
EP	1682846	B1	1/2014
EP	3144630	B1	1/2020
GB	916870	A	1/1963
RU	2633904	C1	10/2017
WO	2001004452	A1	1/2001
WO	0159401	A1	8/2001
WO	2001059401	A1	8/2001
WO	2006054081	A1	5/2006
WO	2008102110	A1	8/2008
WO	2009091422	A2	7/2009
WO	2009117548	A1	9/2009
WO	2012006357	A2	1/2012
WO	2015006869	A1	1/2015
WO	2015134719	A1	9/2015
WO	2017029240	A1	2/2017
WO	2017062444	A1	4/2017
WO	2018009223	A1	1/2018
WO	2018177733	A1	10/2018
WO	2019148009	A2	8/2019

WO	2020150232	A1	7/2020
WO	2020200935	A1	10/2020
WO	2021198180	A1	10/2021

OTHER PUBLICATIONS

Dynaenergetics Europe GMBH; Exposed Gun Subs & Accessories; dated May 23, 2017; <https://www.dynaenergetics.com/products/hardware-and-tcp/perforating-gun-systems/exposed-gun-sub-accessories>.

Harrison Jet Guns; Image of “xtra penetrator”, Aug. 16, 2021.

International Searching Authority; International Preliminary Report on Patentability of the International Searching Authority for PCT/EP2020/058241; dated Oct. 14, 2021; 14 pages.

International Searching Authority; International Search Report and Written Opinion of the International Searching Authority for PCT/EP2021/057570; dated Sep. 13, 2021; 21 pages.

International Searching Authority; International Searching Authority Partial Search Report and Invitation to Pay Additional Search Fees for PCT/EP2021/057570; dated Jul. 22, 2021; 17 pages.

Schlumberger; Selective Perforation: A Game Changer in Perforating Technology—Case Study; issued 2012; 14 pages.

Amit Govil, Selective Perforation: A Game Changer in Perforating Technology—Case Study, presented at the 2012 European and West African Perforating Symposium, Schlumberger, Nov. 7-9, 2012, 14 pgs.

Austin Powder Company; A-140 F & Block, Detonator & Block Assembly; Jan. 5, 2017; 2 pgs.; https://www.austinpowder.com/wp-content/uploads/2019/01/OilStar_A140Fbk-2.pdf.

Baker Hughes, Long Gun Deployment Systems IPS-12-28; 2012 International Perforating Symposium; Apr. 26-27, 2011; 11 pages.

Baker Hughes; SurePerf Rapid Select-Fire System Perforate production zones in a single run; 2012; 2 pages.

Dynaenergetics, DYNAslect Electronic Detonator 0015 SFDE RDX 1.4B, Product Information, Dec. 16, 2011, 1 pg.

Dynaenergetics, DYNAslect Electronic Detonator 0015 SFDE RDX 1.4S, Product Information, Dec. 16, 2011, 1 pg.

Dynaenergetics, DYNAslect System, information downloaded from website, Jul. 3, 2013, 2 pages, <http://www.dynaenergetics.com/>.

Dynaenergetics, Electronic Top Fire Detonator, Product Information Sheet, Jul. 30, 2013, 1 pg.

Dynaenergetics, Gun Assembly, Product Summary Sheet, May 7, 2004, 1 page.

Dynaenergetics, Selective Perforating Switch, information downloaded from website, Jul. 3, 2013, 2 pages, <http://www.dynaenergetics.com/>.

Dynaenergetics, Selective Perforating Switch, Product Information Sheet, May 27, 2011, 1 pg.

Eric H. Findlay, Jury Trial Demand in Civil Action No. 6:20-cv-00069-ADA, dated Apr. 22, 2020, 32 pages.

Gilliat et al.; New Select-Fire System: Improved Reliability and Safety in Select Fire Operations; 2012; 16 pgs.

Horizontal Wireline Services, Presentation of a completion method of shale demonstrated through an example of Marcellus Shale, Pennsylvania, USA, Presented at 2012 International Perforating Symposium (Apr. 26-28, 2012), 17 pages.

Hunting Titan Inc.; Petition for Post Grant Review of U.S. Pat. No. 10,429,161; dated Jun. 30, 2020; 109 pages.

Hunting Titan, Wireline Top Fire Detonator Systems, Nov. 24, 2014, 2 pgs, <http://www.hunting-intl.com/titan/perforating-guns-and-setting-tools/wireline-top-fire-detonator-systems>.

Jet Research Center Inc., JRC Catalog, 2008, 36 pgs., https://www.jetresearch.com/content/dam/jrc/Documents/Books_Catalogs/06_Dets.pdf.

Jet Research Center Inc., Red RF Safe Detonators Brochure, 2008, 2 pages, www.jetresearch.com.

Owen Oil Tools & Pacific Scientific; RF-Safe Green Det, Side Block for Side Initiation, Jul. 26, 2017, 2 pgs.

Owen Oil Tools, Recommended Practice for Oilfield Explosive Safety, Presented at 2011 MENAPS Middle East and North Africa Perforating Symposium, Nov. 28-30, 2011, 6 pages.

Schlumberger & Said Abubakr, Combining and Customizing Technologies for Perforating Horizontal Wells in Algeria, Presented at 2011 MENAPS, Nov. 28-30, 2011, 20 pages.

Smylie, Tom, New Safe and Secure Detonators for the Industry's consideration, presented at Explosives Safety & Security Conference, Marathon Oil Co, Houston; Feb. 23-24, 2005, 20 pages.

U.S. Patent Trial and Appeal Board, Institution of Inter Partes Review of U.S. Pat. No. 9,581,422, Case IPR2018-00600, Aug. 21, 2018, 9 pages.

United States District Court for the Southern District of Texas Houston Division, Case 4:19-cv-01611 for U.S. Pat. No. 9,581,422B2, Plaintiff's Complaint and Exhibits, dated May 2, 2019, 26 pgs.

United States District Court for the Southern District of Texas Houston Division, Case 4:19-cv-01611 for U.S. Pat. No. 9,581,422B2, Defendant's Answers, Counterclaims and Exhibits, dated May 28, 2019, 135 pgs.

United States District Court for the Southern District of Texas Houston Division, Case 4:19-cv-01611 for U.S. Pat. No. 9,581,422B2, Plaintiffs' Motion to Dismiss and Exhibits, dated Jun. 17, 2019, 63 pgs.

United States Patent and Trademark Office, Case IPR2018-00600 for U.S. Pat. No. 9,581,422 B2, Reply In Support of Patent Owner's Motion to Amend, dated Mar. 21, 2019, 15 pgs.

United States Patent and Trademark Office, Case IPR2018-00600 for U.S. Pat. No. 9,581,422 B2, Decision of Precedential Opinion Panel, Granting Patent Owner's Request for Hearing and Granting Patent Owner's Motion to Amend, dated Jul. 6, 2020, 27 pgs.

United States Patent and Trademark Office, Case IPR2018-00600 for U.S. Pat. No. 9,581,422 B2, DynaEnergetics GmbH & Co. KG's Patent Owner Preliminary Response, dated May 22, 2018, 47 pgs.

United States Patent and Trademark Office, Case IPR2018-00600 for U.S. Pat. No. 9,581,422 B2, Order Granting Precedential Opinion Panel, Paper No. 46, dated Nov. 7, 2019, 4 pgs.

United States Patent and Trademark Office, Case IPR2018-00600 for U.S. Pat. No. 9,581,422 B2, Patent Owner's Motion to Amend, dated Dec. 6, 2018, 53 pgs.

United States Patent and Trademark Office, Case IPR2018-00600 for U.S. Pat. No. 9,581,422 B2, Patent Owner's Opening Submission to Precedential Opinion Panel, dated Dec. 20, 2019, 21 pgs.

United States Patent and Trademark Office, Case IPR2018-00600 for U.S. Pat. No. 9,581,422 B2, Patent Owner's Request for Hearing, dated Sep. 18, 2019, 19 pgs.

United States Patent and Trademark Office, Case IPR2018-00600 for U.S. Pat. No. 9,581,422 B2, Patent Owner's Responsive Submission to Precedential Opinion Panel, dated Jan. 6, 2020, 16 pgs.

United States Patent and Trademark Office, Case IPR2018-00600 for U.S. Pat. No. 9,581,422 B2, Patent Owner's Sur-reply, dated Mar. 21, 2019, 28 pgs.

United States Patent and Trademark Office, Case IPR2018-00600 for U.S. Pat. No. 9,581,422 B2, Petitioner's Additional Briefing to the Precedential Opinion Panel, dated Dec. 20, 2019, 23 pgs.

United States Patent and Trademark Office, Case IPR2018-00600 for U.S. Pat. No. 9,581,422 B2, Petitioner's Opposition to Patent Owner's Motion to Amend, dated Mar. 7, 2019, 30 pgs.

United States Patent and Trademark Office, Case IPR2018-00600 for U.S. Pat. No. 9,581,422 B2, Petitioner's Reply Briefing to the Precedential Opinion Panel, dated Jan. 6, 2020, 17 pgs.

United States Patent and Trademark Office, Case IPR2018-00600 for U.S. Pat. No. 9,581,422 B2, Petitioner's Reply in Inter Partes Review of Patent No. 9,581,422, dated Mar. 7, 2019, 44 pgs.

United States Patent and Trademark Office, Final Written Decision of Case IPR2018-00600 for U.S. Pat. No. 9,581,422 B2, Paper No. 42, dated Aug. 20, 2019, 31 pgs.

United States Patent and Trial Appeal Board; Final Written Decision on IPR2018-00600; dated Aug. 20, 2019; 31 pages.

Schlumberger; Exposed Perforating Gun Systems Through-tubing capsule gun systems; <https://www.slb.com/completions/well-completions/perforating/perforating-gun-systems/exposed#related-information>; Oct. 26, 2020; 5 pages.

International Searching Authority, International Search and Written Opinion of International App. No. PCT/EP2020/058241, dated Aug. 10, 2020, 18 pgs.

* cited by examiner

Primary Examiner — Derrick E Holland

(74) *Attorney, Agent, or Firm* — Moyles IP, LLC

(57) **CLAIM**

We claim the ornamental design of a shaped charge casing, as shown and described.

DESCRIPTION

FIG. 1 is a front, top perspective view of a shaped charge casing showing our new design;

FIG. 2 is a front, bottom perspective view of the shaped charge casing of FIG. 1;

FIG. 3 is a front elevated view of the shaped charge casing of FIG. 1;

FIG. 4 is a rear elevated view of the shaped charge casing of FIG. 1;

FIG. 5 is a left-side elevated view of the shaped charge casing of FIG. 1;

FIG. 6 is a right-side elevated view of the shaped charge casing of FIG. 1;

FIG. 7 is a top plan view of the shaped charge casing of FIG. 1;

FIG. 8 is a bottom plan view of the shaped charge casing of FIG. 1; and,

FIG. 9 is a cross-section view of the shaped charge casing taken along line 9-9 of FIG. 7.

The broken lines consisting of a double-dot/dash pattern define the bounds of the claimed design and form no part thereof.

1 Claim, 5 Drawing Sheets

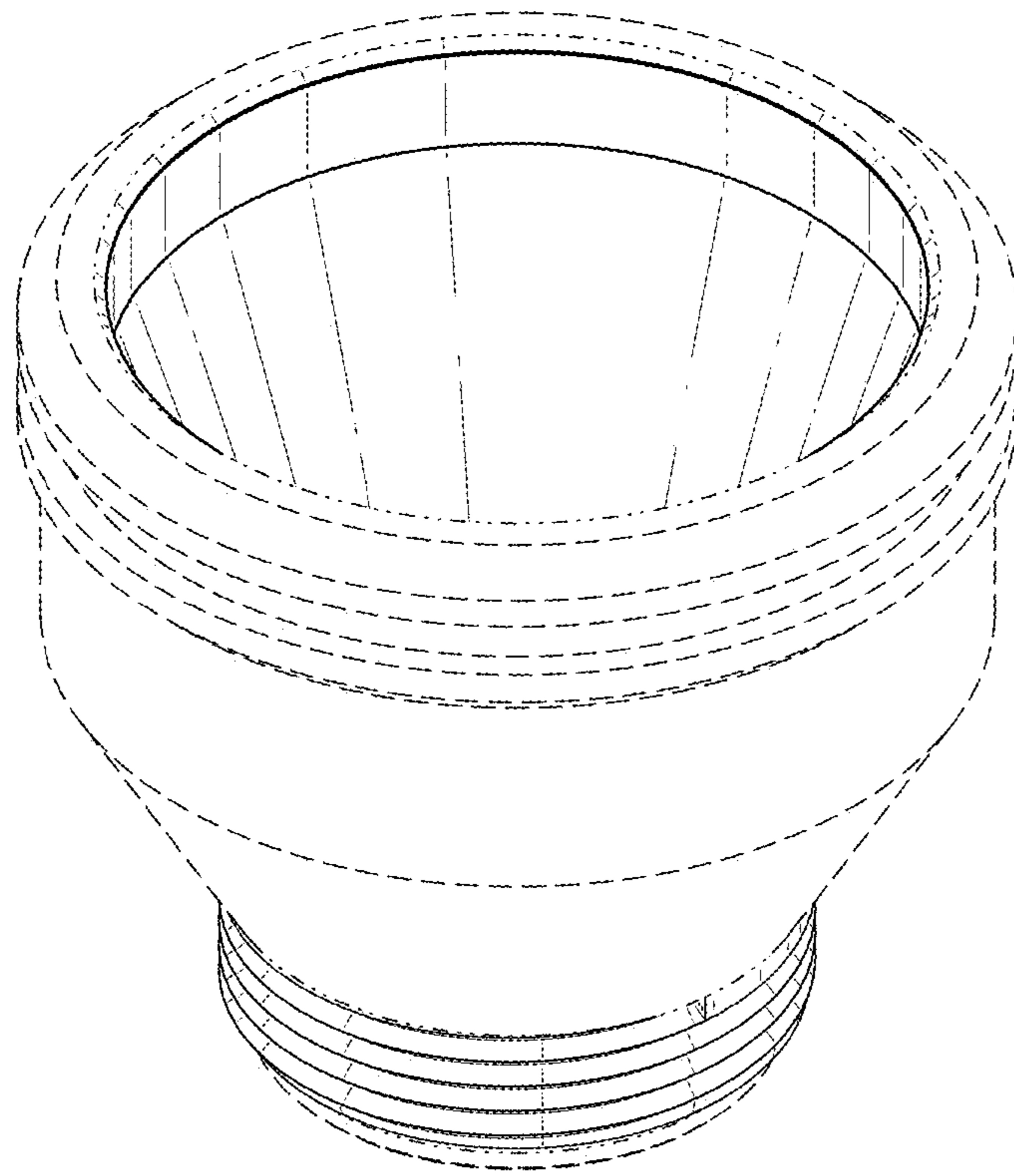

FIG. 1

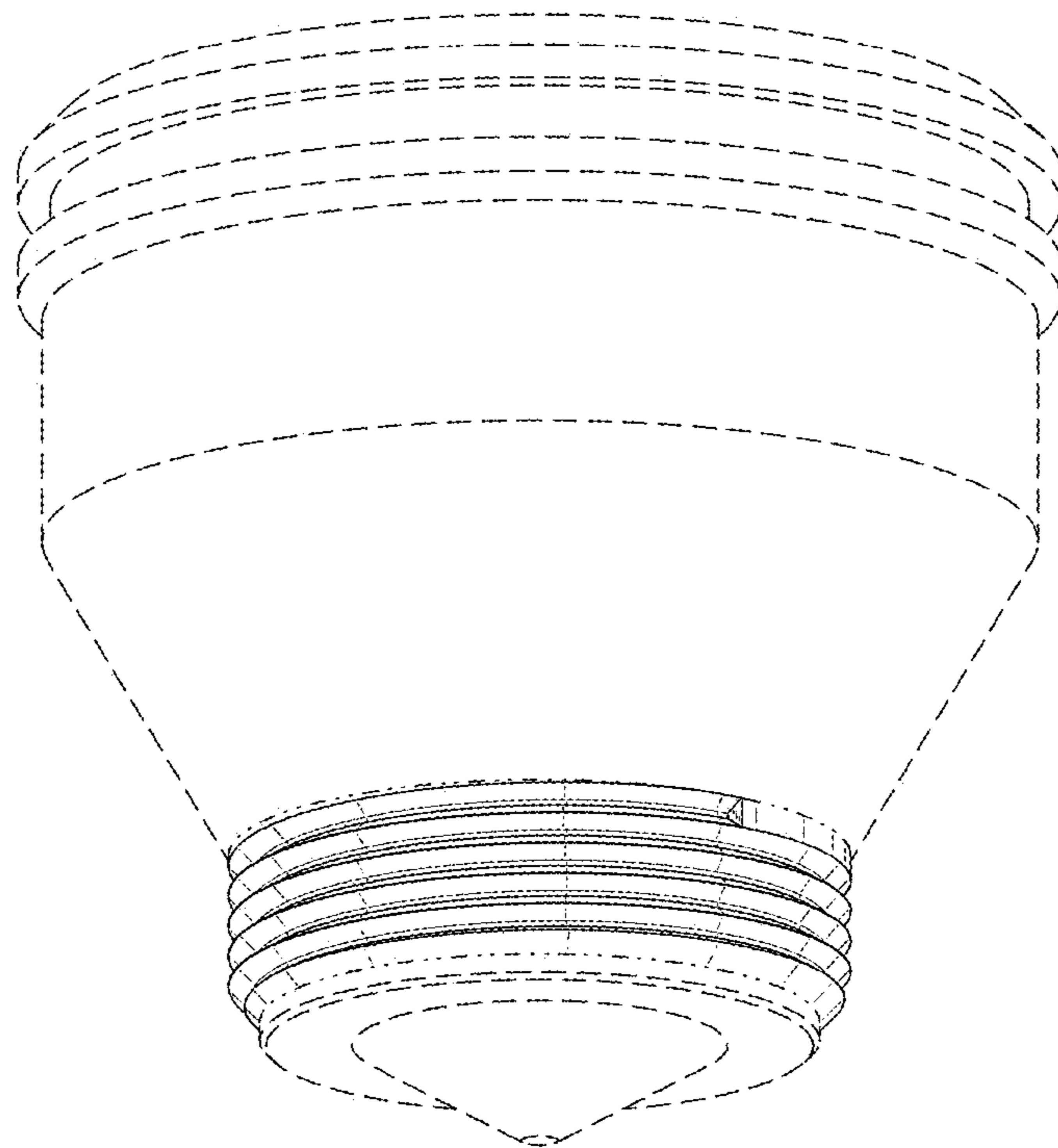

FIG. 2

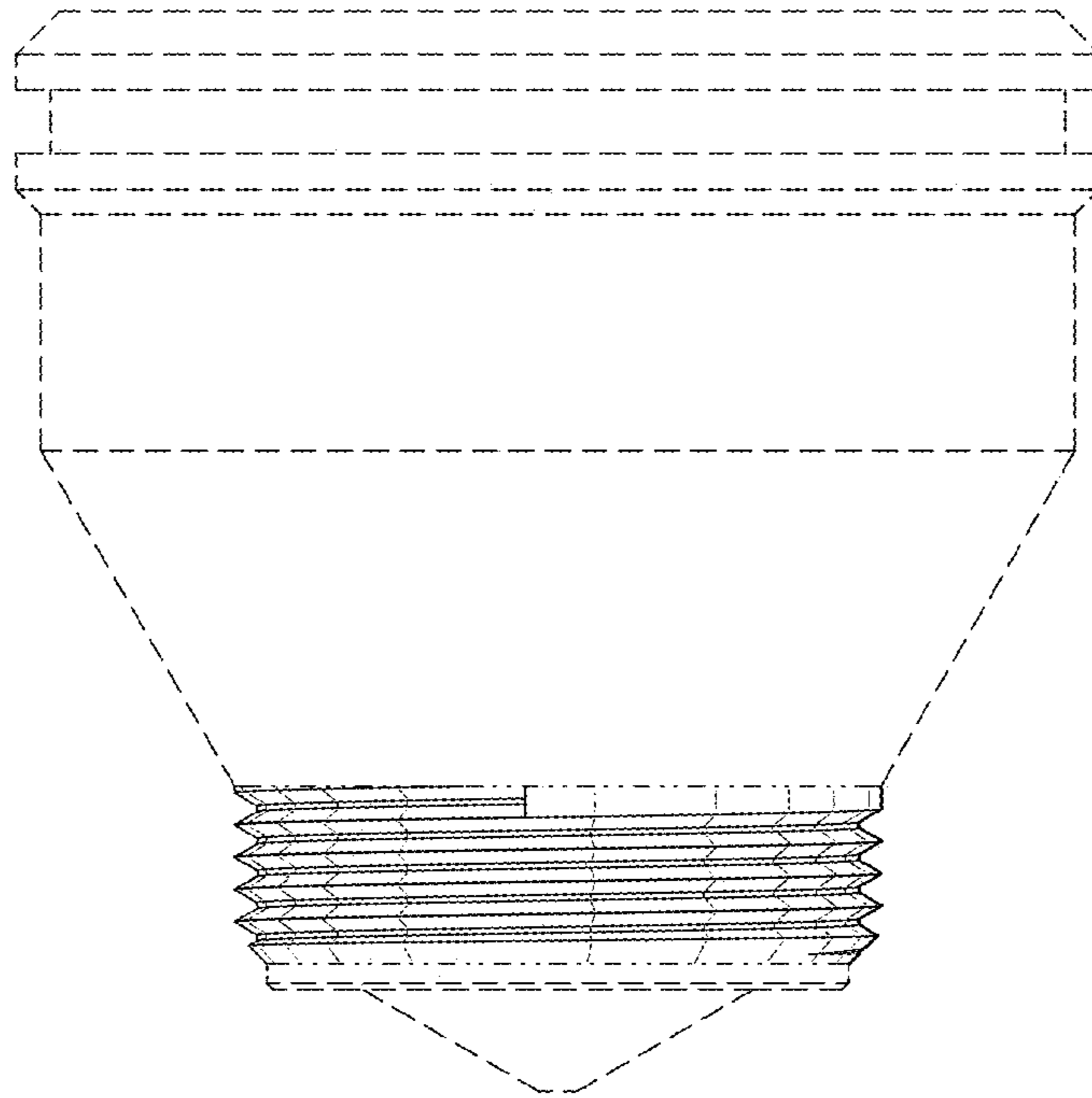

FIG. 3

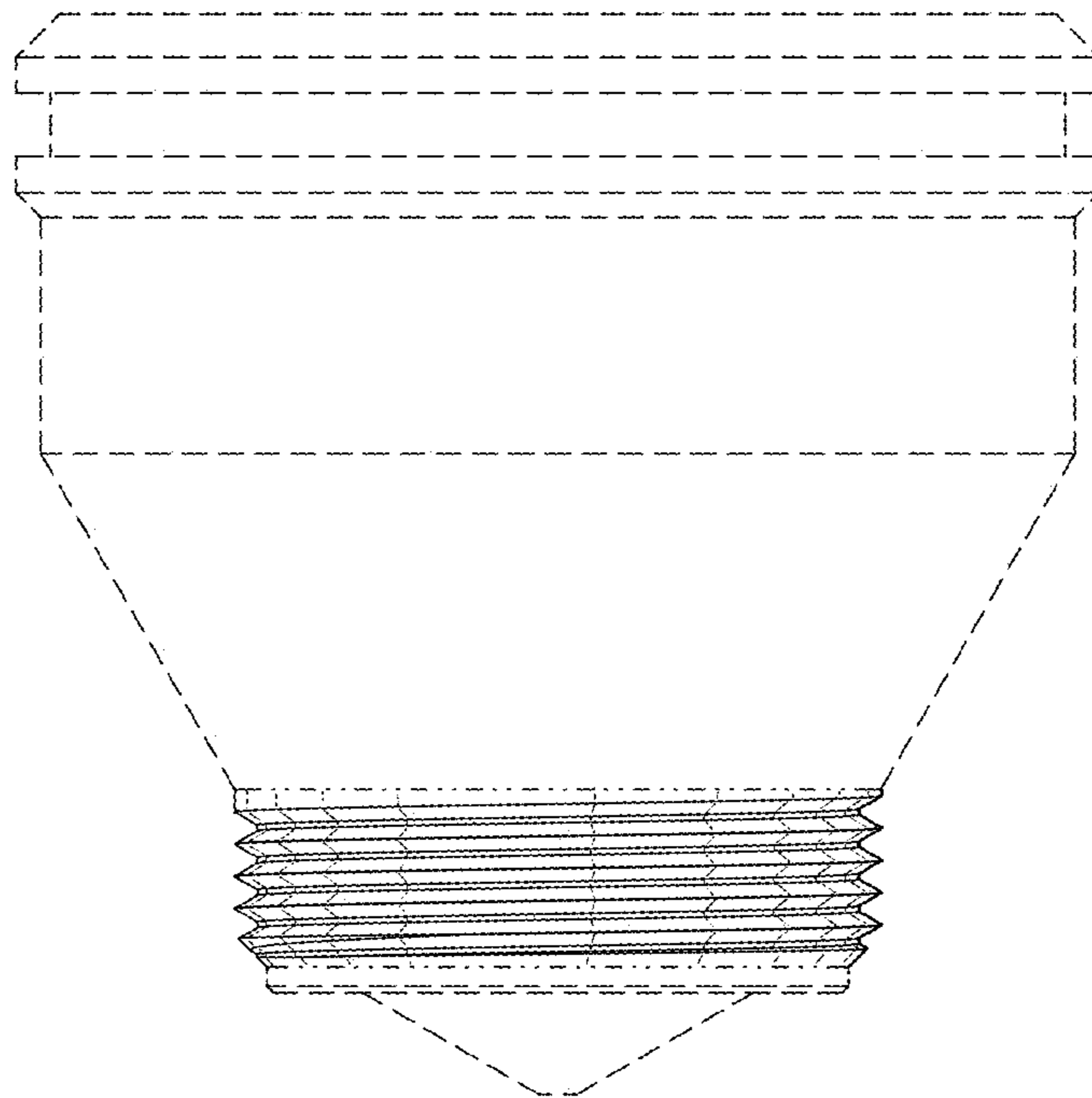

FIG. 4

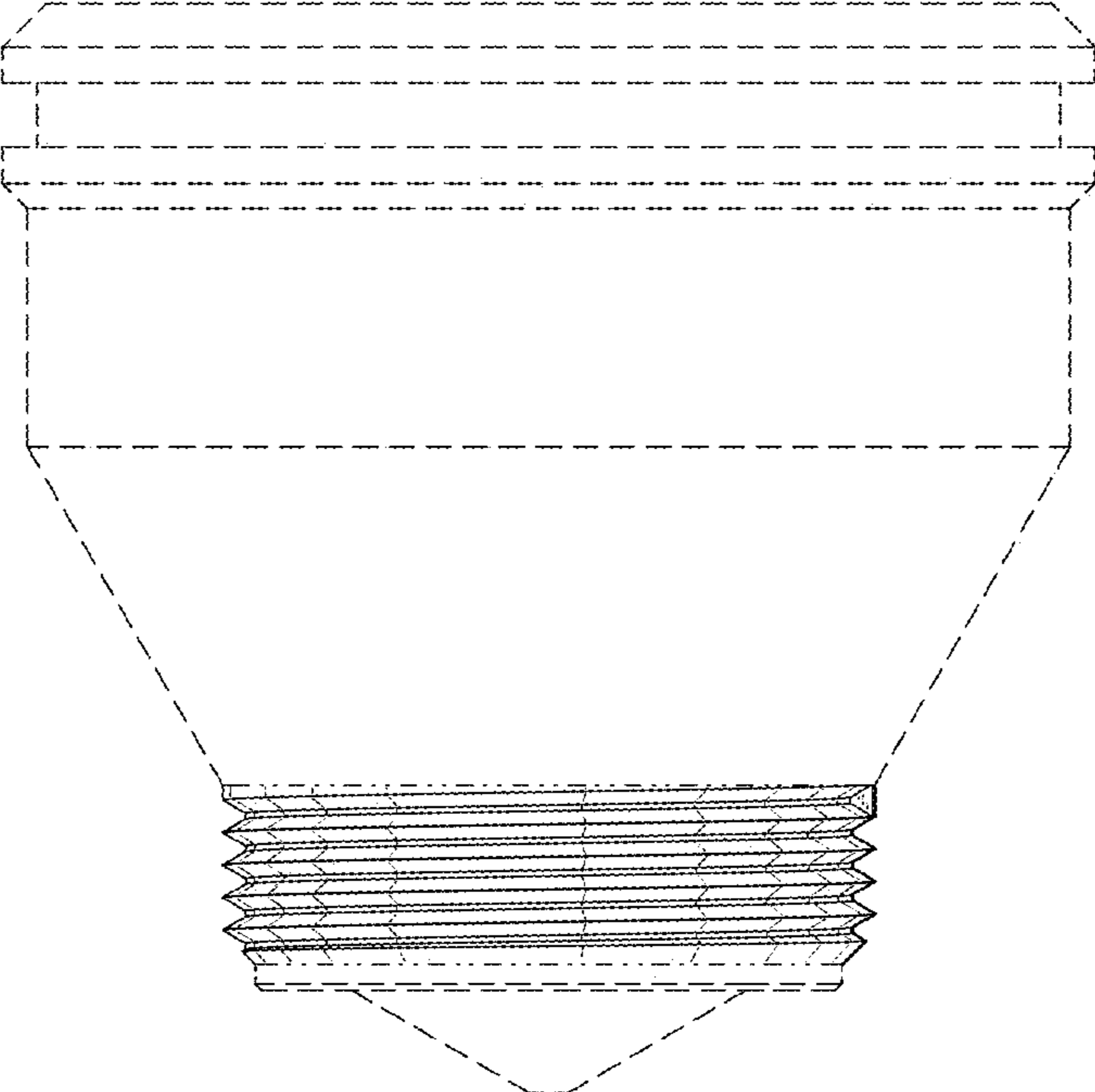

FIG. 5

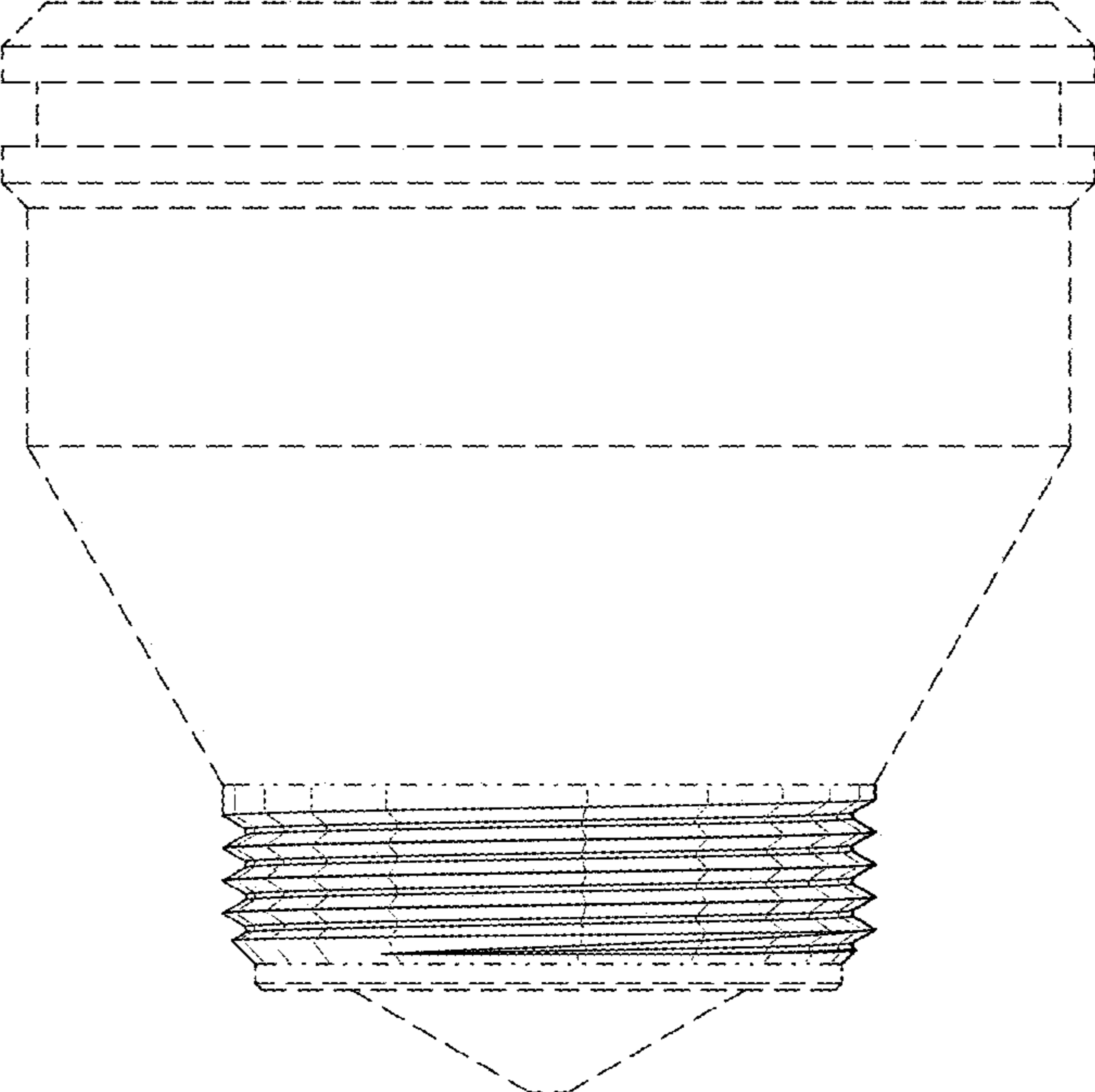

FIG. 6

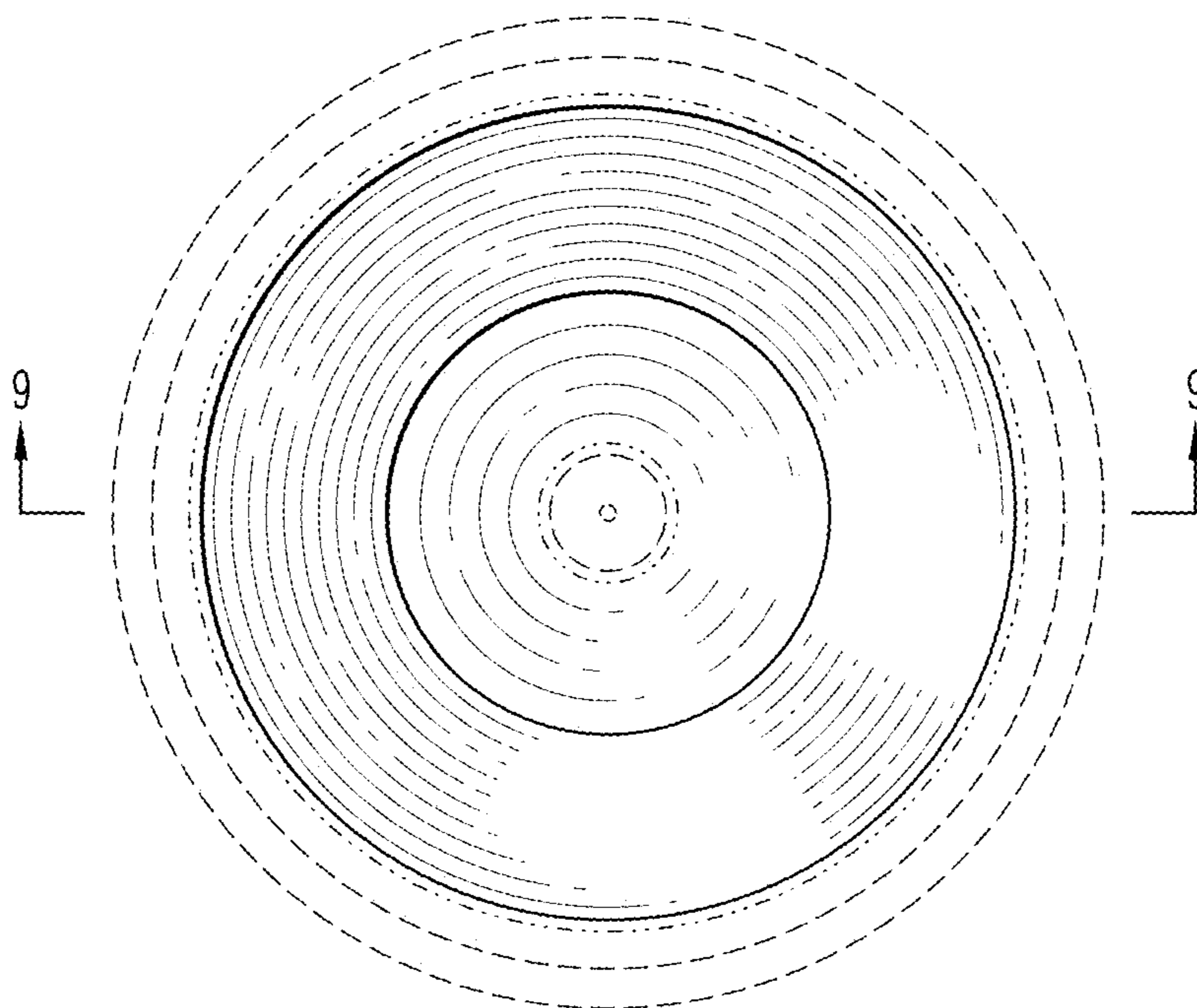

FIG. 7

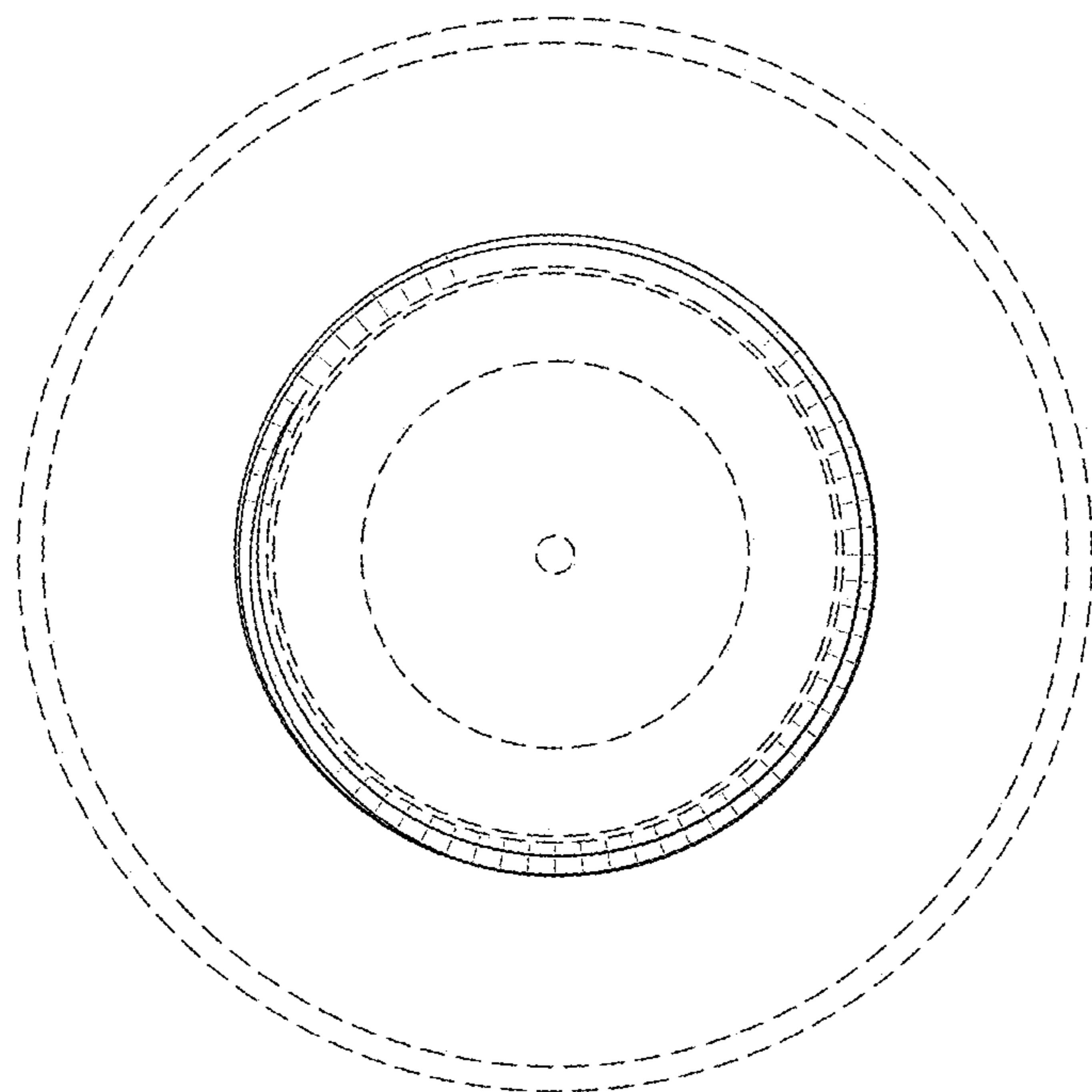

FIG. 8

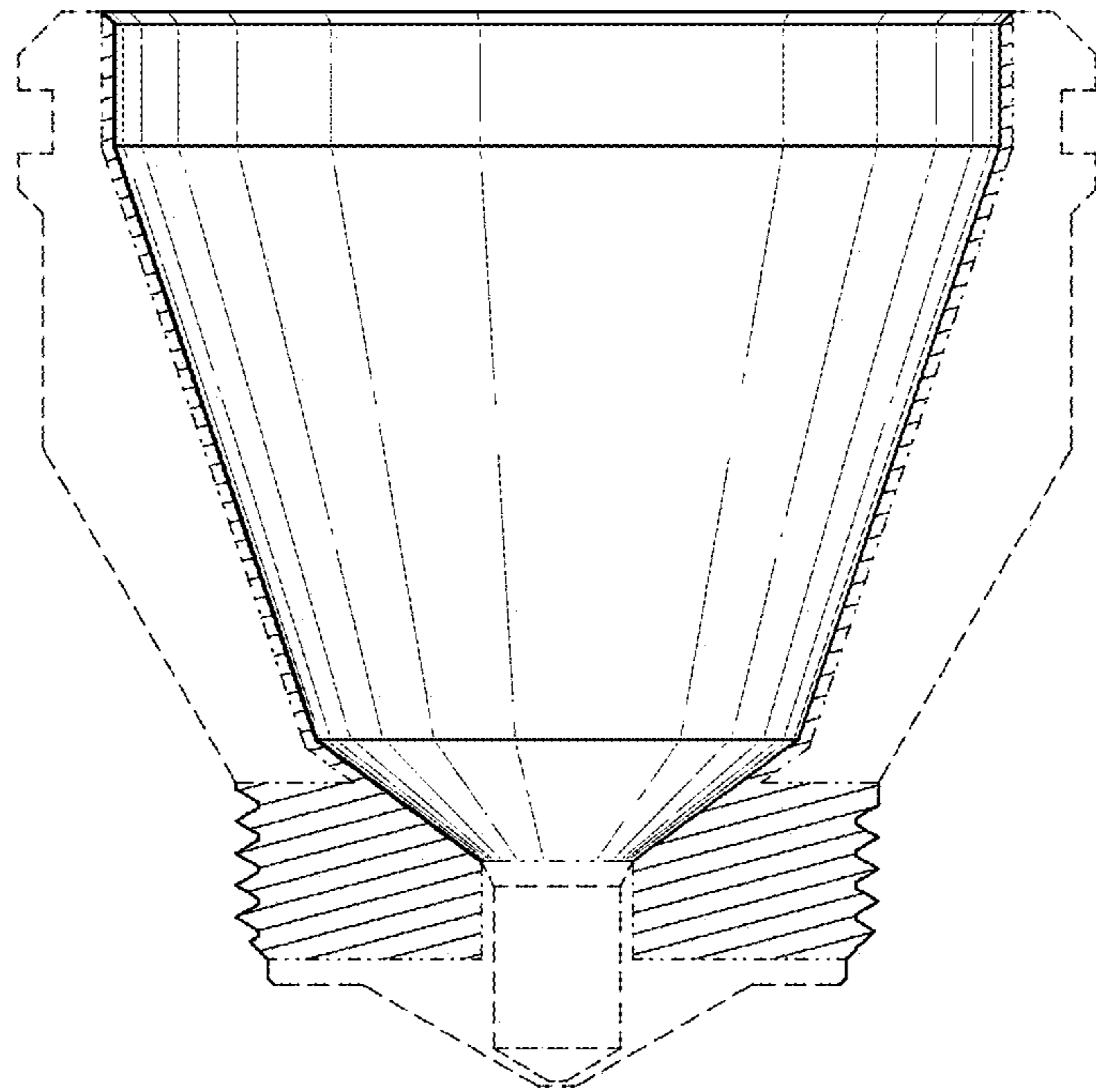

FIG. 9