



US00D980434S

(12) **United States Design Patent**
Eaves, III et al.

(10) **Patent No.:** **US D980,434 S**
(45) **Date of Patent:** **** Mar. 7, 2023**

(54) **MEDICAL ARTICLE FOR TREATING A WOUND AND/OR SCAR TISSUE**

(71) Applicant: **EMRGE, LLC**, Atlanta, GA (US)

(72) Inventors: **Felmont F. Eaves, III**, Atlanta, GA (US); **Gary W. Knight**, Lebanon, OH (US)

(73) Assignee: **EMRGE, LLC**, Atlanta, GA (US)

(**) Term: **15 Years**

(21) Appl. No.: **29/766,256**

(22) Filed: **Jan. 14, 2021**

(51) **LOC (14) Cl.** **24-01**

(52) **U.S. Cl.**

USPC **D24/189**

(58) **Field of Classification Search**

USPC D24/188, 189, 191, 192, 206; D28/27, D28/39, 42, 75

CPC A61B 17/085; A61B 17/00491; A61B 17/064; A61B 17/10; A61B 2017/00862; A61B 2017/00951

See application file for complete search history.

(56) **References Cited**

U.S. PATENT DOCUMENTS

815,264 A 3/1906 Chambers
1,248,450 A 12/1917 Burke
1,908,229 A 5/1933 Dyer

(Continued)

FOREIGN PATENT DOCUMENTS

AU 2012236205 B2 8/2016
AU 2016262734 12/2016

(Continued)

OTHER PUBLICATIONS

Semantic Scholar. Figure 3. 2018. <https://www.semanticscholar.org/paper/Force-Modulating-Tissue-Bridges-for-Reduction-of-of-Kazmer-Eaves/24212ae9f9ffc6fad1e923418edd9052724a05d3/figure/2> (Year: 2018).*

(Continued)

Primary Examiner — Darcey E Gottschalk

(74) *Attorney, Agent, or Firm* — Additon, Pendleton & Witherspoon, P.A.

(57) **CLAIM**

The ornamental design for a medical article for treating a wound and/or scar tissue, as shown and described.

DESCRIPTION

FIG. 1 is a top perspective view of a medical article for treating a wound and/or scar tissue in accordance with the present invention;

FIG. 2 is a top plan view of the medical article of FIG. 1; FIG. 3 is a bottom plan view of the medical article of FIG. 1;

FIG. 4 is a front elevation view of the medical article of FIG. 1;

FIG. 5 is a rear elevation view of the medical article of FIG. 1;

FIG. 6 is a right elevation view of the medical article of FIG. 1;

FIG. 7 is a left elevation view of the medical article of FIG. 1;

FIG. 8 is a cross-sectional view of the medical article of FIG. 1 taken along line 8-8 of FIG. 2, wherein a cross-sectional view taken in the opposite direction along line 8-8 of FIG. 2 is the same as FIG. 8; and,

FIG. 9 is an exploded bottom perspective view of the medical article of FIG. 1.

In the drawings, the broken lines depict portions of a medical article for treating a wound and/or scar tissue that form no part of the claimed design. Further, the dot-dash broken lines define bounds of the claimed design and form no part of the claimed design.

1 Claim, 7 Drawing Sheets

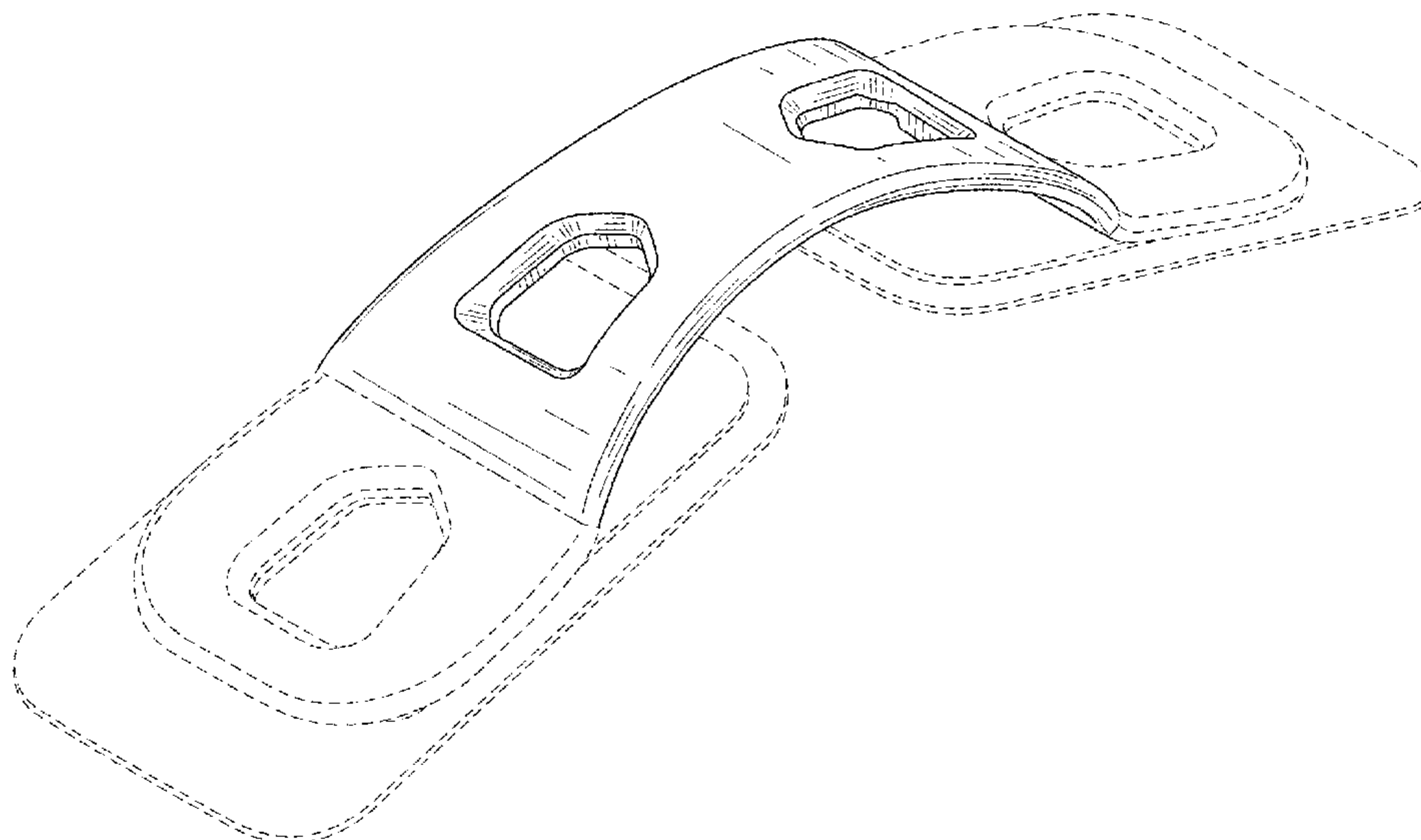

(56)

References Cited

U.S. PATENT DOCUMENTS

2,254,620 A	9/1941	Miller	9,421,133 B2	8/2016	Hu et al.
D134,810 S	1/1943	Tawdish	9,492,171 B2	11/2016	Petenaude
2,341,121 A	2/1944	Schaaff	9,517,163 B2	12/2016	Goldman et al.
2,371,978 A	3/1945	Perham	D780,317 S	2/2017	Vandervoort
2,421,193 A	5/1947	Gardner	9,603,596 B2	3/2017	Riskin et al.
2,679,671 A	6/1954	Garber, Jr.	9,649,226 B2	5/2017	Zepeda et al.
2,912,735 A	2/1957	Johnson et al.	D790,072 S	6/2017	Hiebert
3,014,483 A	12/1961	McCarthy	9,668,922 B2	6/2017	Zepeda et al.
3,068,870 A	12/1962	Levin	D811,609 S	2/2018	Huff
3,082,773 A	3/1963	Renstrom et al.	D815,747 S	4/2018	Kellock et al.
3,120,687 A	2/1964	Greening et al.	9,974,532 B2	5/2018	Baas et al.
3,487,836 A	1/1970	Niebel et al.	10,064,616 B2	9/2018	Lear et al.
3,625,220 A	12/1971	Engelsner	D831,220 S	10/2018	Chase et al.
3,695,271 A	10/1972	Chodorow	10,213,350 B2	2/2019	Jackson et al.
3,831,608 A	8/1974	Kletschka et al.	D847,429 S *	4/2019	Sze D28/42
3,861,008 A	1/1975	Wannag	10,327,774 B2 *	6/2019	Eaves A61B 17/085
4,011,639 A	3/1977	Koleske	D854,246 S *	7/2019	Toba D28/39
4,275,736 A	6/1981	Chodorow	D862,695 S	10/2019	Eaves, III et al.
D260,681 S	9/1981	Chodorow et al.	D863,563 S *	10/2019	Herder D24/189
4,506,669 A	3/1985	Blake, III	D863,564 S *	10/2019	Herder D24/189
4,539,990 A	9/1985	Stivala	10,426,479 B2	10/2019	Vold et al.
4,646,731 A	3/1987	Brower	10,517,768 B2	12/2019	Zepeda et al.
4,702,251 A	10/1987	Sheehan	D876,641 S	2/2020	Eaves, III et al.
D293,717 S	1/1988	Proulx et al.	D876,653 S	2/2020	Heller
4,734,320 A	3/1988	Ohira et al.	D887,640 S *	6/2020	LaFauci D28/42
4,742,826 A	5/1988	McLorg	10,857,037 B2	12/2020	Jackson et al.
4,815,468 A	3/1989	Annand	10,939,912 B2	3/2021	Leung et al.
4,825,866 A	5/1989	Pierce	D918,400 S	5/2021	Ma
5,047,047 A	9/1991	Yoon	11,051,988 B2	7/2021	Belson
5,127,412 A	7/1992	Cosmetto et al.	D936,846 S *	11/2021	Eaves, III D24/189
5,176,703 A	1/1993	Peterson	D938,599 S *	12/2021	Kersen D24/192
5,230,701 A	7/1993	Meyer et al.	D956,243 S	6/2022	Hood
5,236,440 A	8/1993	Hlavacek	2002/0111641 A1	8/2002	Peterson et al.
5,366,480 A	11/1994	Corriveau et al.	2003/0221700 A1	12/2003	La Fauci
D354,134 S	1/1995	Tanaka	2005/0080453 A1	4/2005	Lebner
D359,144 S	6/1995	Healzer et al.	2005/0193527 A1	9/2005	Gould
5,489,083 A	2/1996	Rollor	2006/0200198 A1	9/2006	Riskin et al.
5,549,713 A	8/1996	Kim	2009/0125052 A1	5/2009	Pinna et al.
5,562,705 A	10/1996	Whiteford	2009/0151128 A1	6/2009	Gould
5,630,430 A	5/1997	Shultz et al.	2009/0240186 A1	9/2009	Frang
5,775,345 A	7/1998	Chou	2009/0259203 A1	10/2009	Hu et al.
D407,489 S	3/1999	Kalat	2010/0051046 A1	3/2010	Stevenson et al.
5,947,917 A	9/1999	Carte et al.	2010/0081983 A1	4/2010	Zocher
5,947,998 A	9/1999	Cartmell et al.	2010/0228287 A1	9/2010	Jeekel
6,176,868 B1	1/2001	Detour	2010/0236566 A1	9/2010	Stachowski
6,196,228 B1	3/2001	Kreitzer et al.	2010/0262126 A1	10/2010	Hu et al.
6,559,350 B1	5/2003	Tetreault et al.	2011/0004173 A1	1/2011	Hu et al.
6,894,204 B2	5/2005	Dunshee	2011/0023906 A1	2/2011	Tu
D530,420 S	10/2006	Chesnin	2011/0040325 A1	2/2011	Moehrle
7,332,641 B2	2/2008	Lebner et al.	2011/0054547 A1	3/2011	Anderson
7,683,234 B2	3/2010	Gurtner et al.	2011/0105963 A1	5/2011	Hu et al.
7,834,232 B2	11/2010	Rastegar et al.	2011/0152738 A1	6/2011	Zepeda et al.
8,157,839 B2	4/2012	Riskin et al.	2012/0172779 A1	7/2012	Spinelli et al.
8,183,428 B2	5/2012	Gurtner et al.	2012/0221044 A1	8/2012	Archibald et al.
8,246,590 B2	8/2012	Hu et al.	2012/0226214 A1	9/2012	Gurtner et al.
D667,167 S	9/2012	Stewart	2013/0150899 A1	6/2013	Sixto, Jr. et al.
D671,265 S	11/2012	Stewart	2013/0178897 A1	7/2013	Wu et al.
8,323,313 B1	12/2012	Belson et al.	2013/0282049 A1	10/2013	Peterson et al.
D674,544 S	1/2013	Stewart	2014/0066943 A1	3/2014	Sixto, Jr. et al.
8,395,011 B2	3/2013	Zepeda et al.	2014/0107597 A1	4/2014	Hu et al.
8,435,221 B2	5/2013	Hu et al.	2014/0128819 A1	5/2014	Eaves
D683,860 S	6/2013	Quimby	2014/0227483 A1	8/2014	Eaves
D690,020 S	9/2013	Quimby	2014/0243901 A1	8/2014	Mebarak et al.
8,562,576 B2	10/2013	Hu et al.	2014/0336701 A1	11/2014	McLorg
8,592,640 B2	11/2013	Zepeda et al.	2015/0005722 A1	1/2015	Hu et al.
8,674,164 B2	3/2014	Zepeda et al.	2015/0012037 A1	1/2015	Goldman et al.
8,834,434 B2	9/2014	Hu et al.	2015/0112311 A1	4/2015	Hammond et al.
8,915,942 B2	12/2014	Zhang	2015/0305739 A1	10/2015	Rolandi et al.
9,028,529 B2	5/2015	Riskin et al.	2016/0324693 A1	11/2016	Hu et al.
9,050,086 B2	6/2015	Belson et al.	2017/0049630 A1	2/2017	Goldman et al.
9,089,328 B2	7/2015	Belson et al.	2017/0071596 A1	3/2017	Lear et al.
9,119,620 B2	9/2015	Peterson et al.	2017/0333039 A1	11/2017	Leung
9,241,835 B2	1/2016	Zepeda et al.	2018/0125492 A1	5/2018	Eaves
D754,862 S	4/2016	Huff	2018/0303483 A1	10/2018	Zhang
9,301,760 B2	4/2016	Fox	2018/0338757 A1	11/2018	Lear et al.
			2018/0353335 A1	12/2018	Walker
			2019/0038474 A1	2/2019	Eaves

(56)

References Cited

U.S. PATENT DOCUMENTS

2019/0133582 A1 5/2019 Eaves et al.
2019/0261989 A1 8/2019 Eaves

FOREIGN PATENT DOCUMENTS

CA	2830918	A1	10/2012
CN	1889903	A	1/2007
CN	101606856		12/2009
CN	101828939	B	9/2010
CN	201683935	U	12/2010
CN	103892877	A	7/2014
CN	104755033	A	7/2015
CN	105147344	A	12/2015
CN	205144638	U	4/2016
CN	103533900	A	12/2016
EP	2691029	A2	2/2014
FR	419096		10/1910
FR	794710		2/1936
JP	2011-500170	A	1/2011
JP	2014-516288		7/2014
KR	10-2009-0066415	A	6/2009
KR	10-2014-0020993		2/2014
TW	M340039	U	9/2008
WO	02/26181	A1	4/2002
WO	2006/124671	A2	11/2006
WO	2009049232	A1	4/2009
WO	2011/019859	A2	2/2011
WO	2013188884	A1	6/2012
WO	2012/135735		10/2012
WO	2013/059600		4/2013
WO	2013/059600	A1	4/2013
WO	2018/075879	A1	4/2014
WO	2014/070922	A1	5/2014
WO	2016/0107897	A1	7/2016
WO	2017/079782	A1	5/2017
WO	2018/075879		4/2018
WO	2021/072021	A1	4/2021

OTHER PUBLICATIONS

Intelligence 360. Marietta Georgia Based Brijjit Medical is Raising \$10,086,884.00 In New Equity Investment . . . Aug. 10, 2021. <https://www.intelligence360.news/marietta-georgia-based-brijjit-medical-is-raising-10086884-00-in-new-equity-investment/> (Year: 2021).*

Brijjit. Force Modulating Tissue Bridges. Apr. 2021. https://brijjitmedical.com/wp-content/uploads/2021/04/BRIJJIT_IFU_20215203_v2.pdf (Year: 2021).*

Extended Search Report in related EP Application 12762897.2, dated May 27, 2015, 11 pages.

Japanese Office Action in related JP Application No. 2014-502866, dated Dec. 10, 2015, Translation provided, 11 pages.

Chinese First Office Action in related CN Application No. 201280017051.4, dated Jun. 1, 2015, Translation provided, 13 pages.

Chinese Second Office Action in related CN Application No. 201280017051.4, dated Dec. 31, 2015, Translation provided, 8 pages.

Australian Patent Examination Report No. 1 in related Australian Patent Application No. 201226205, dated Aug. 28, 2015, 5 pages.

International Search Report and Written Opinion issued in commonly owned PCT/US2012/031638 dated Nov. 29, 2012; 10 pages.

Supplementary Partial European Search Report in commonly owned EP Application No. 12762897, dated Dec. 23, 2014, 7 pages.

Japanese Notice of Reasons for Rejection in related JP Application No. 2014-502866, dated Oct. 3, 2016; 9 pages.

Southmedic Inc., SutureSafe Instructions for Use, 2 pages [Downloaded Jul. 25, 2017 from http://dynamicissuesystems.com/wp-content/uploads/2015/09/IFU0251_E.pdf].

SutureSafe Inc., Product Brochure SutureSafe Support closed wounds and provide stability; 2 pages [Downloaded Jul. 25, 2017 from <http://dynamicissuesystems.com/wp-content/uploads/2015/09/SutureSafe-SS-Ir2.pdf>].

Search Report in related PCT Application No. PCT/2018/057569, dated Feb. 2, 2018, pp. 1-6.

Written Opinion in related PCT Application No. PCT/2018/057569, dated Apr. 26, 2018, pp. 1-5.

International Preliminary Report on Patentability in commonly owned International Application No. PCT/US2017/057569, dated May 2, 2019, pp. 1-6.

Amazon, “Elastic Bandage Wrap Compression Tape”, Review by Maria A. Dec. 18, 2017, <URL:<https://www.amazon.com/Elastic-Bandage-Wrap-Compression-Tape/dp/B06XQ8BY8?th=1>> (Year 2017) 12 pages.

Japanese Notice of Reasons for Rejection in related JP Application No. 2014-502866, dated of Oct. 3, 2016; 9 pages.

Supplementary Partial European Search Report in related EP Application No. 12762897, dated Dec. 23, 2014, 7 pages.

Examination Report No. 1 in related Australian Application No. 2016262734, dated Jan. 14, 2019, 3 pages.

Kyle Design, Hair Barrettes Made in France—Extra Large 4" Blank Metal, No date specified, <https://www.kyledesigns.com/hair-barrettes-made-in-france-extra-large-4-blank-metal/> (Year: 0) 4 pages.

First Chinese Office Action in related CN Application No. 201611102500.1, dated Aug. 20, 2018, 21 pages (including English Translation).

Summons to attend oral proceedings in related European Application No. 12762897.2 dated Mar. 22, 2021, pp. 1-11.

Partial Supplementary European Search Report in related European Application No. 17861546.4 dated Apr. 22, 2020, pp. 1-12.

Search Report in related European Application No. 17861546.4 dated Jul. 31, 2020, pp. 1-10.

International Search Report and Written Opinion in counterpart International Application No. PCT/US20/54702 dated Mar. 11, 2021, pp. 1-28.

Ruckel, U.S. Pat. No. 765,793 issued Jul. 26, 1904, pp. 1-3.

Knott et al., “Curved bistable composite slit tubes with positive Gaussian curvature”, University of Surrey, Guilford, United Kingdom, pp. 1-22.

Jiang et al., “Snapping of bistable, prestressed cylindrical shells”, A Letters Journal Exploring, www.ep1journal.org, Jun. 2018, EPL, 122 (2018) 64003, pp. 1-8.

Kebadze, et al., “Bistable prestressed shell structures”, International Journal of Solids and Structures, www.elsevier.com/locate/ijssolstr, 41 (2004) pp. 2801-2820.

Kim et al., “Flytrap-inspired robot using structurally integrated actuation based on bistability and developable surface”, Bioinspiration & Biomimetics, 9 (2014) 036004, pp. 1-15.

Seffen, “Morphing’ bistable orthotropic elliptical shallow shells”, Proceedings of the Roayl Society, (2007) 463, 67-83, pp. 1-17.

* cited by examiner

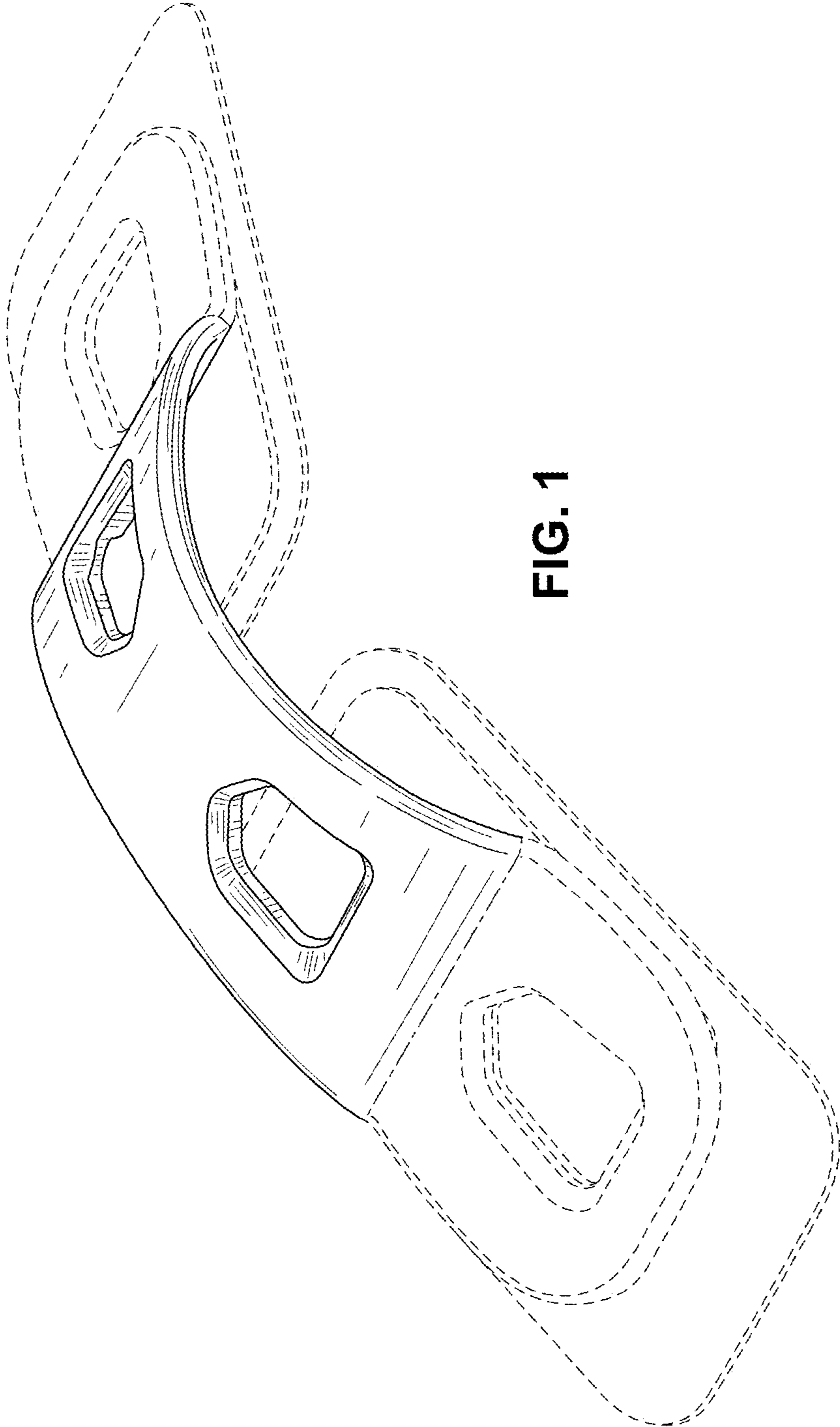

FIG. 1

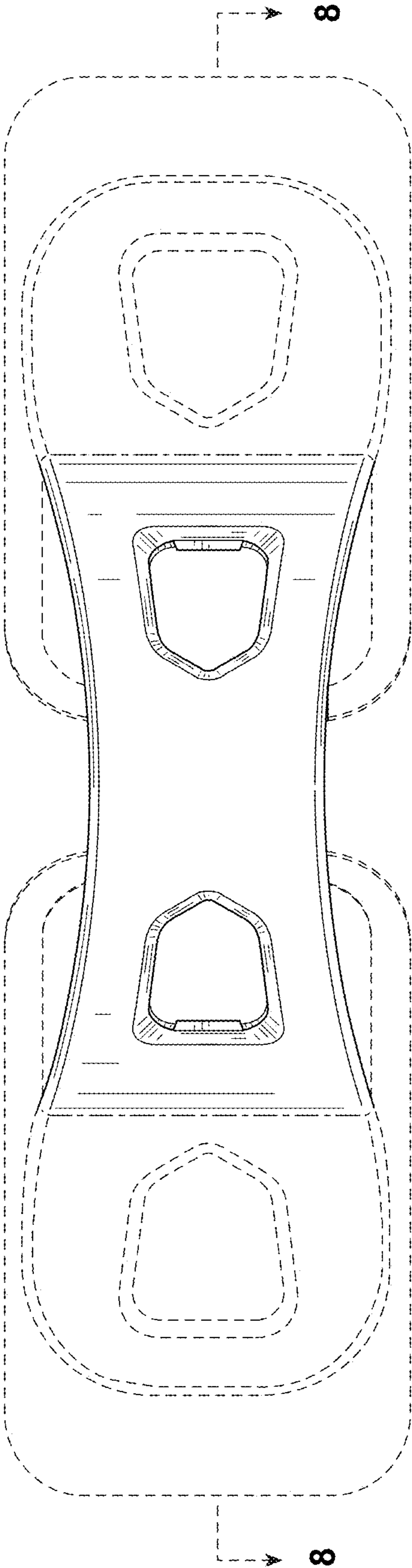

FIG. 2

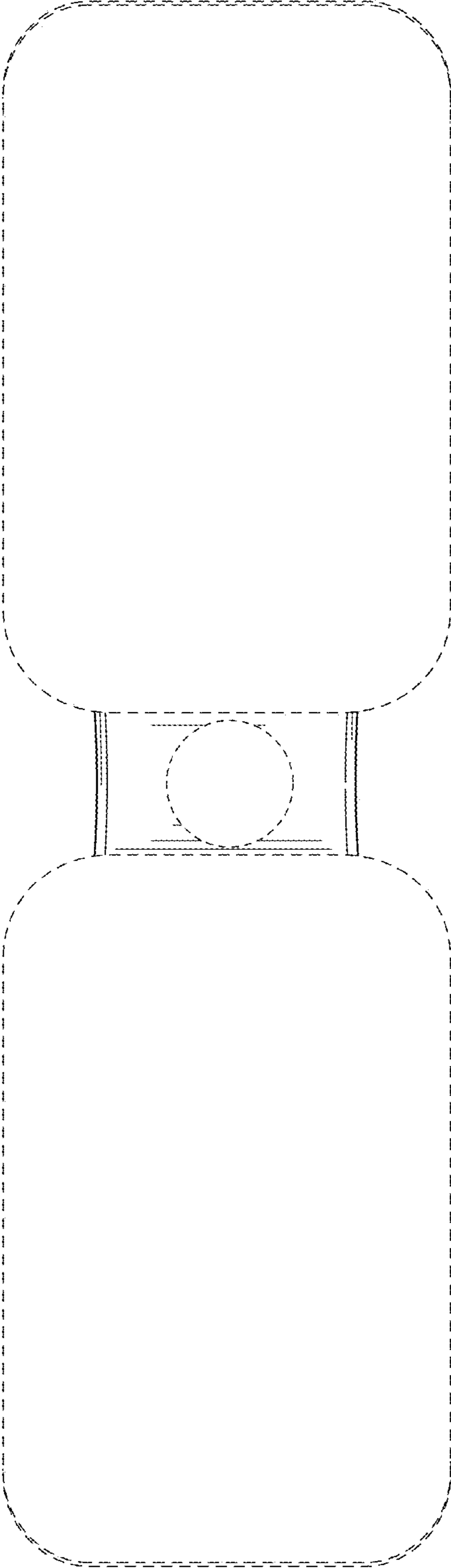

FIG. 3

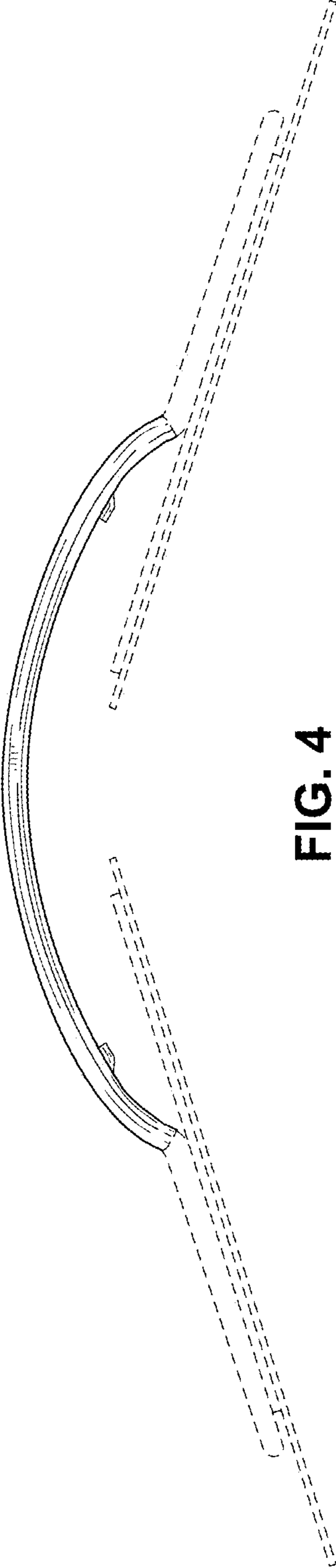

FIG. 4

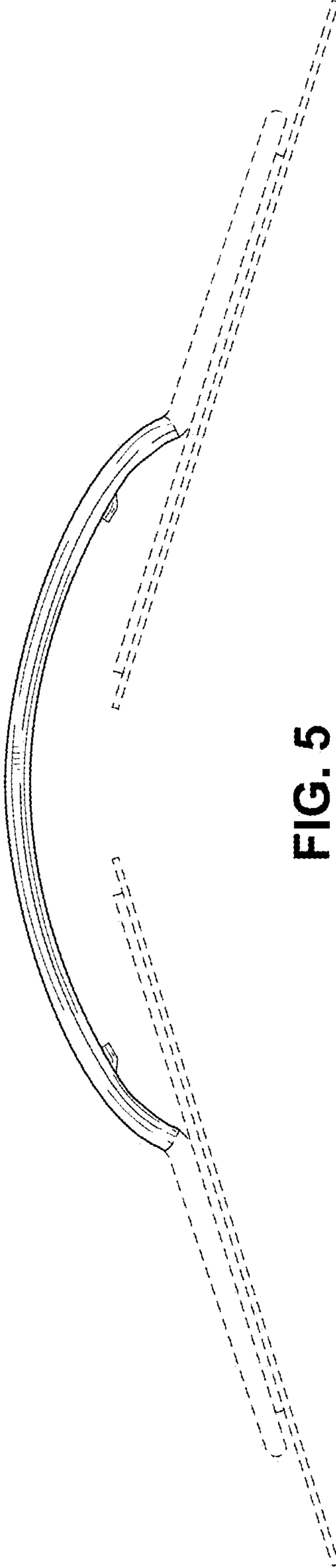

FIG. 5

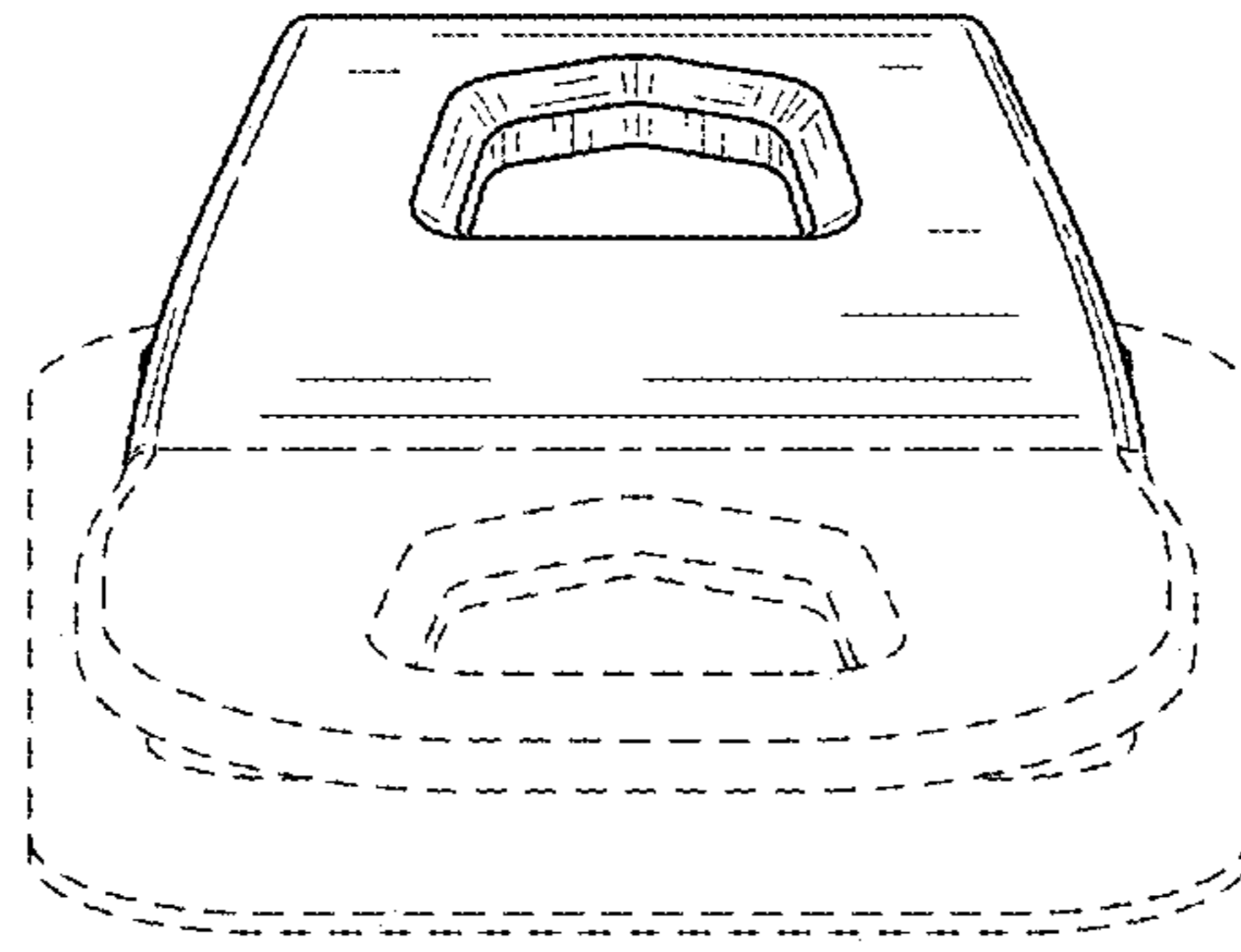

FIG. 6

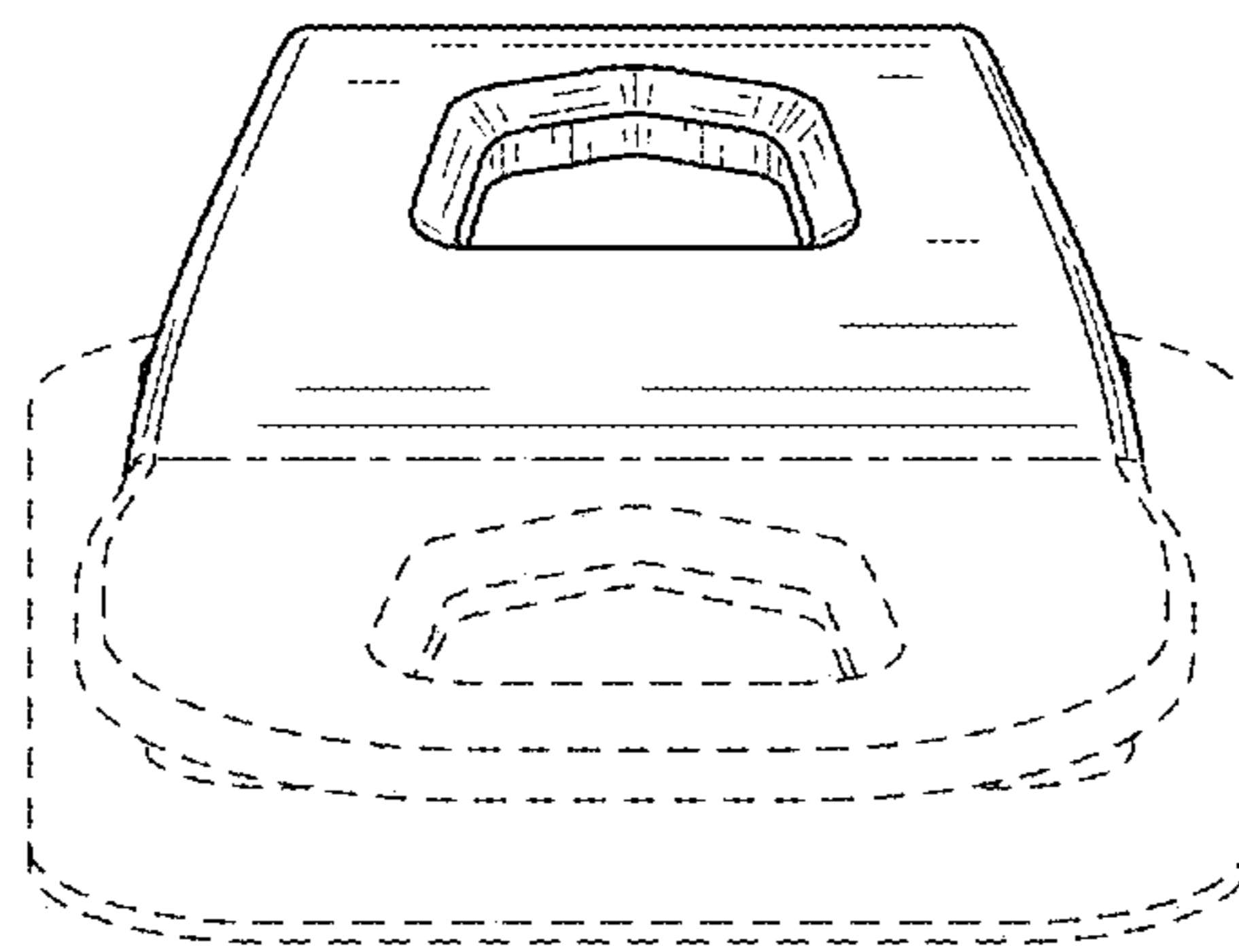

FIG. 7

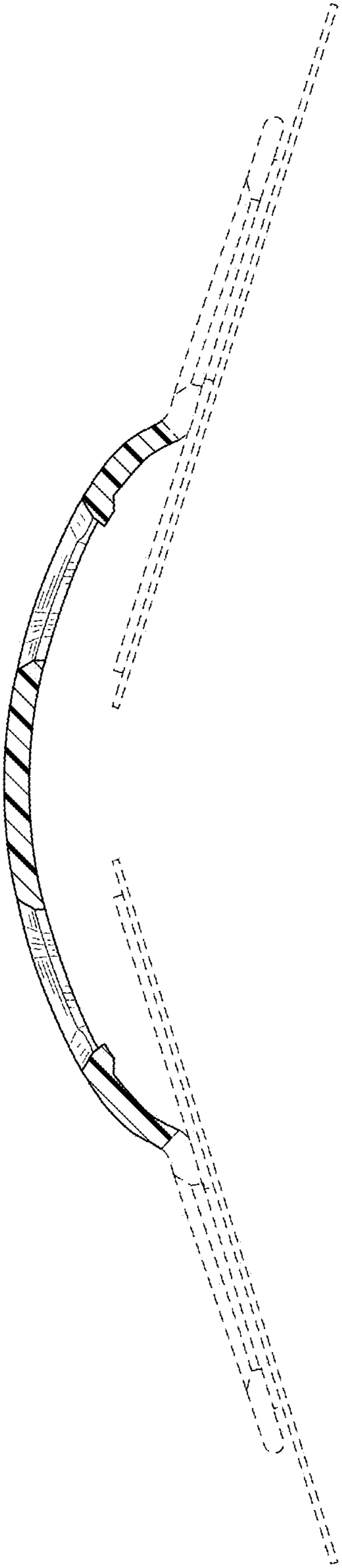

FIG. 8

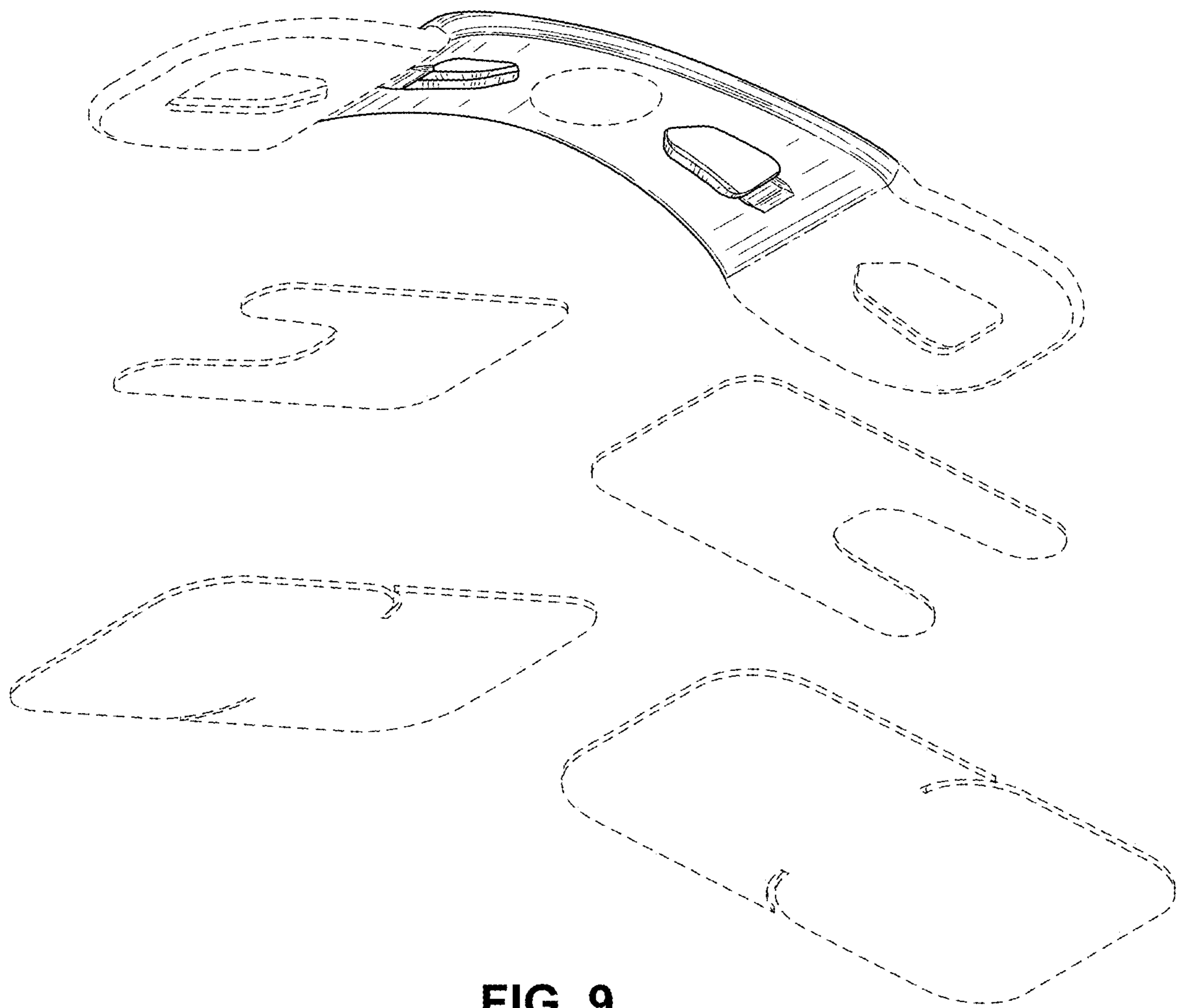

FIG. 9