



US00D979646S

(12) **United States Design Patent** (10) **Patent No.:** **US D979,646 S**  
**Togami et al.** (45) **Date of Patent:** **\*\* Feb. 28, 2023**

(54) **DOCUMENT FOLDER**

(71) Applicant: **KING JIM CO., LTD.**, Tokyo (JP)

(72) Inventors: **Mizuki Togami**, Tokyo (JP); **Koichi Tanimoto**, Tokyo (JP)

(73) Assignee: **KING JIM CO., LTD.**, Tokyo (JP)

(\*\*) Term: **15 Years**

(21) Appl. No.: **35/514,910**

(22) Filed: **Jun. 21, 2022**

(80) **Hague Agreement Data**

Int. Filing Date: **Jun. 21, 2022**

Int. Reg. No.: **DM/222481**

Int. Reg. Date: **Jun. 21, 2022**

Int. Reg. Pub. Date: **Aug. 12, 2022**

(30) **Foreign Application Priority Data**

Dec. 24, 2021 (JP) ..... 2021-028471 D

(51) **LOC (14) Cl.** ..... **19-04**

(52) **U.S. Cl.**

USPC ..... **D19/86**

(58) **Field of Classification Search**

USPC ..... D19/26-33, 76, 86, 99, 100; D9/433,  
D9/634, 711, 713, 715, 722; D3/303,  
D3/227, 900, 248; D6/626

(Continued)

(56) **References Cited**

**U.S. PATENT DOCUMENTS**

2,517,535 A \* 8/1950 Cross ..... A47G 1/0638  
40/778

3,740,879 A \* 6/1973 Patterson ..... B42D 15/00  
40/594

(Continued)

*Primary Examiner* — Richard E Chilcot

(74) *Attorney, Agent, or Firm* — Manabu Kanesaka

(57) **CLAIM**

The ornamental design for a document folder, as shown and described.

**DESCRIPTION**

1.1: Perspective

1.2: Front

1.3: Back

1.4: Top

1.5: Bottom

1.6: Right

1.7: Left

1.8: Enlarged

1.9: Enlarged

1.10: Cross sectional

1.11: Cross sectional

1.12: Perspective View

As shown in the perspective view showing the usage status, the document folder of this article is provided with a pocket for holding the document in the diagonal corner, and a notch is provided on the side of the lower part as the document can be easily taken out; in addition, the upper pocket has a clip inside of it to hold the document; the part to be registered is shown only by the solid line; the part represented by the broken line is not the part of the claimed design in the attached drawing, the alternated long and short dash line shows only the boundary between the part for which the design registration is to be claimed and other parts; fig. 1.1 is a perspective view of the Document folder showing the new design; fig. 1.2 is a front view thereof; fig. 1.3 is a back view thereof; fig. 1.4 is a top view thereof; fig. 1.5 is a bottom view thereof; fig. 1.6 is the right view thereof; fig. 1.7 is a left view thereof; fig. 1.8 is an enlarged view of the part that is to be registered as a design in the upper center of fig. 1.2; fig. 1.9 is an enlarged view of the part on the lower right side of fig. 1.2 that is to be registered; fig. 1.10 is a vertical cross-sectional view taken along 28 percent from the left in fig. 1.8; fig. 1.11 is a vertical cross-sectional view taken along 85 percent from the bottom in fig. 1.6; fig. 1.12 is a perspective view showing how to use this article and the

(Continued)

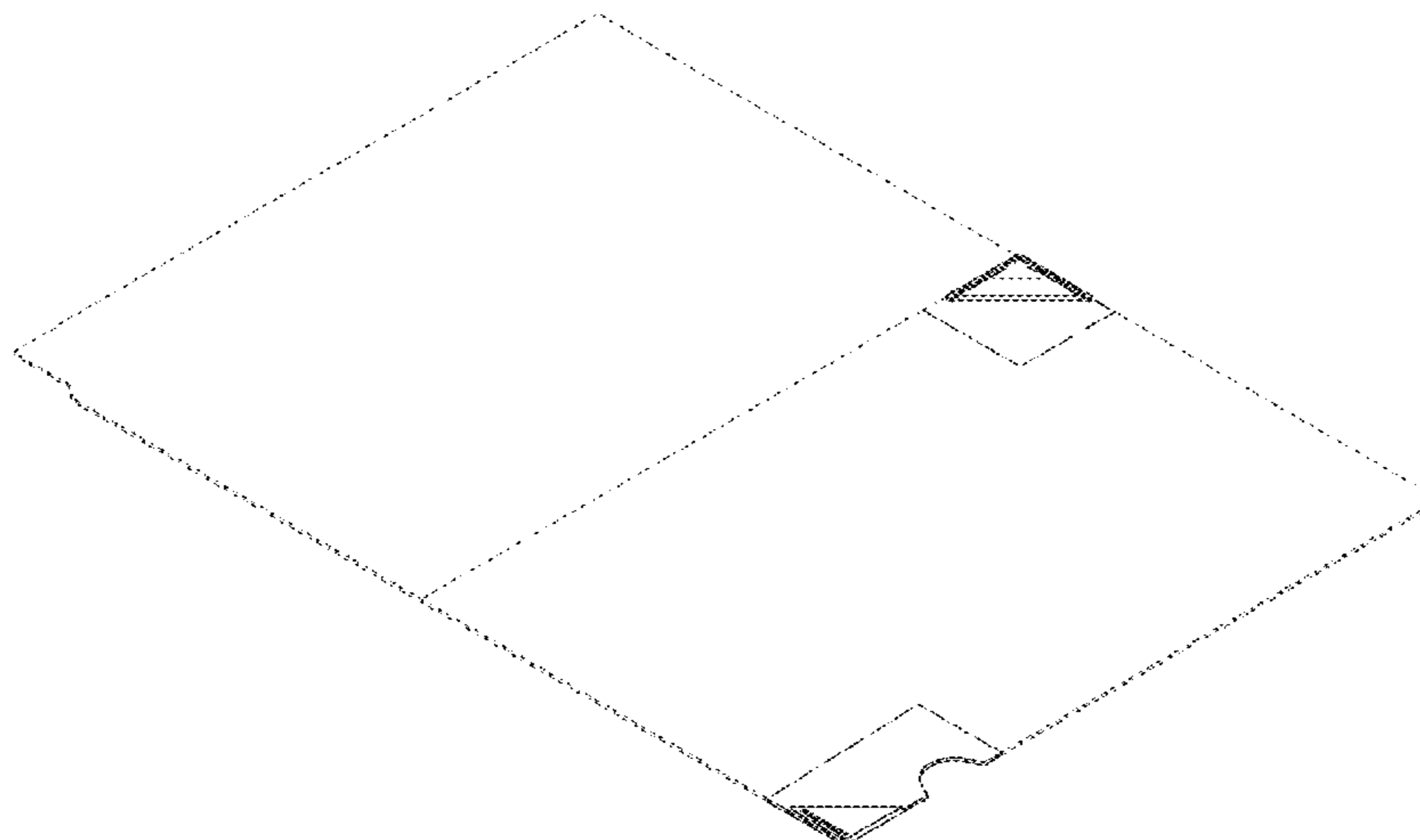

broken line is for the purpose of illustrating portion of the environmental structure and forms no part of the claimed design.

**1 Claim, 12 Drawing Sheets**

(52) **U.S. Cl.**

CPC ..... *B42F 5/00* (2013.01)

(58) **Field of Classification Search**

CPC .... B42F 5/00; B42F 11/00; B42F 5/06; B42F 7/02; B42F 7/04; Y10S 493/947; B42P 2241/08

See application file for complete search history.

(56) **References Cited**

U.S. PATENT DOCUMENTS

4,141,162 A \* 2/1979 Mascolo ..... B42F 5/06  
40/657  
D299,932 S \* 2/1989 Beleckis ..... D19/26  
D302,830 S \* 8/1989 Papat ..... D19/26  
D366,674 S \* 1/1996 Hirai ..... D19/86  
D376,617 S \* 12/1996 Ayers ..... D19/86  
D418,875 S \* 1/2000 Paik ..... D19/86

D421,050 S \* 2/2000 Henrikson ..... D19/86  
D447,170 S \* 8/2001 Wolff ..... D19/86  
6,874,968 B2 \* 4/2005 Schwartz ..... B42F 5/00  
281/38  
D509,541 S \* 9/2005 Kim ..... D19/86  
D511,794 S \* 11/2005 Lucas ..... D19/86  
D556,830 S \* 12/2007 Crowell ..... D11/131  
D565,098 S \* 3/2008 Lesperance, Jr. .... D19/26  
D567,286 S \* 4/2008 Takahashi ..... D19/33  
D577,768 S \* 9/2008 Takahashi ..... D19/27  
7,805,872 B1 \* 10/2010 Ngan ..... G09F 1/10  
40/778  
D631,507 S \* 1/2011 Harrell ..... D19/26  
D639,853 S \* 6/2011 Sutlive ..... D19/32  
D729,872 S \* 5/2015 Leonard ..... D19/26  
D731,592 S \* 6/2015 Rowe ..... D19/27  
D750,169 S \* 2/2016 Russell ..... D19/26  
D821,492 S \* 6/2018 Feingold ..... D19/26  
D827,709 S \* 9/2018 Gayer ..... D19/86  
D845,388 S \* 4/2019 Chui ..... D19/26  
D845,389 S \* 4/2019 Chui ..... D19/27  
D892,928 S \* 8/2020 Leffler ..... D19/26  
D893,618 S \* 8/2020 Coore-Widener ..... G02B 7/182  
D19/26  
10,814,664 B2 \* 10/2020 Kuriyama ..... B42F 7/02  
10,828,927 B2 \* 11/2020 Kuriyama ..... B42F 7/00  
D939,021 S \* 12/2021 Shimizu ..... D19/26  
D939,022 S \* 12/2021 Shimizu ..... D19/26

\* cited by examiner

1.1

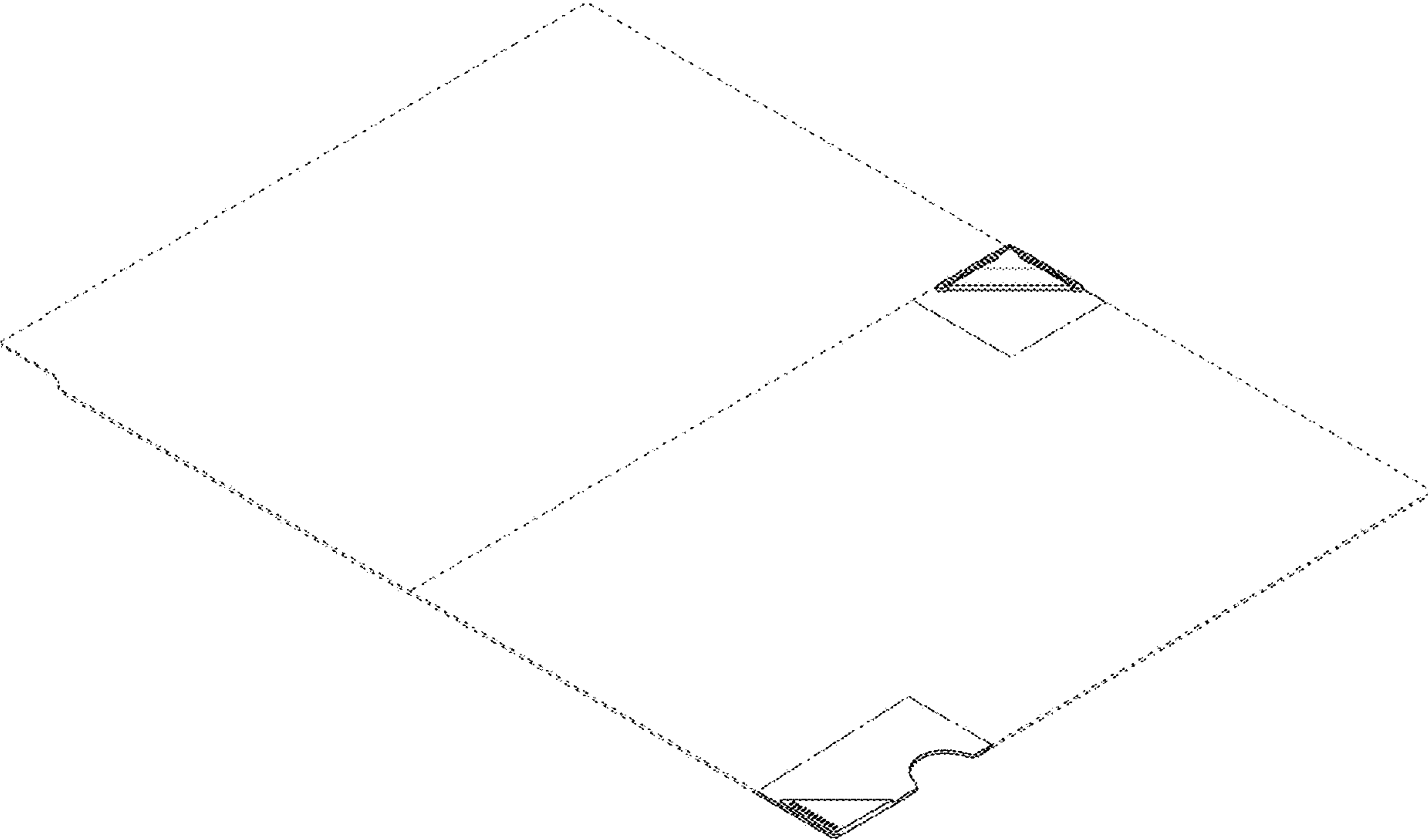

1.2

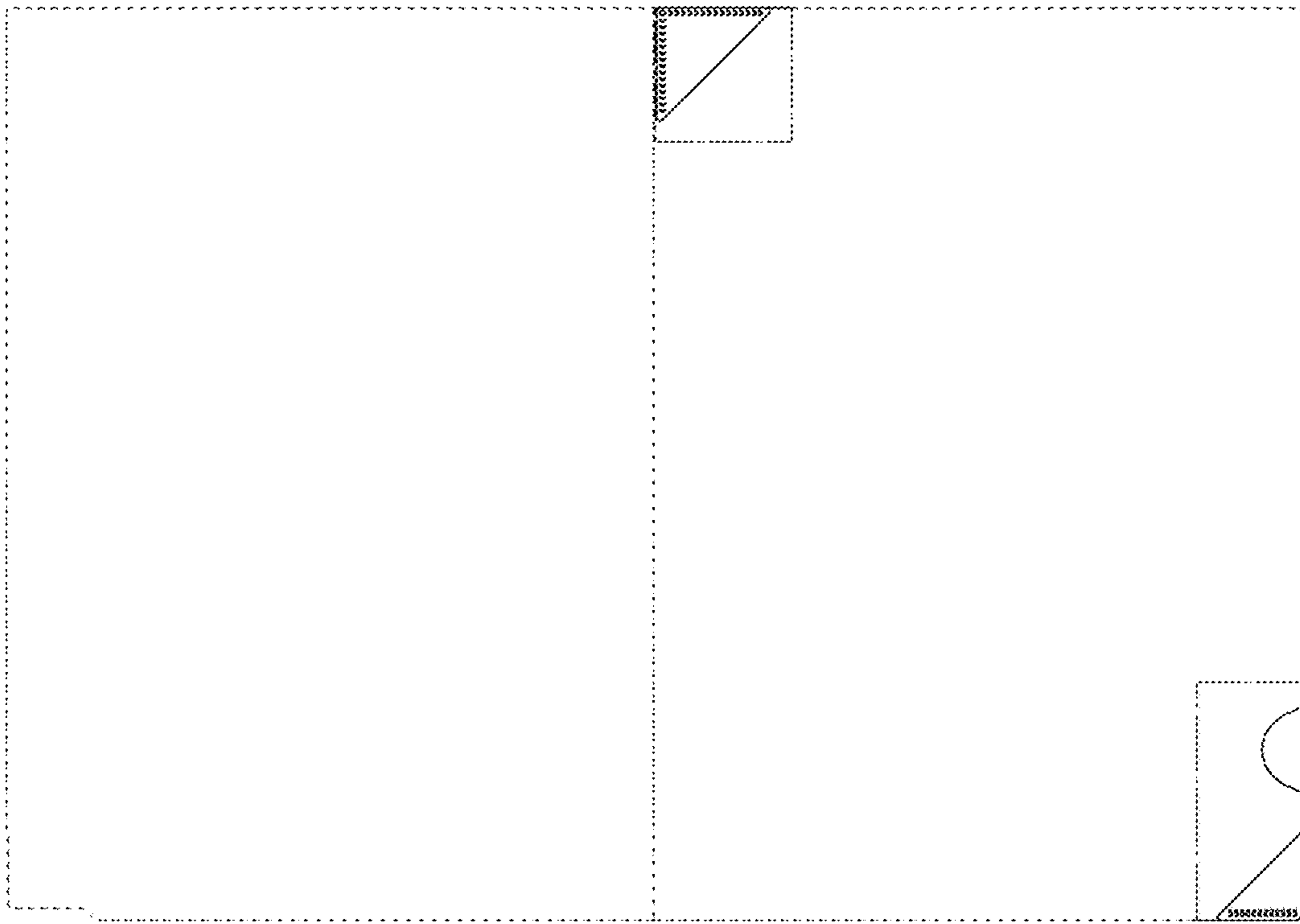

1.3

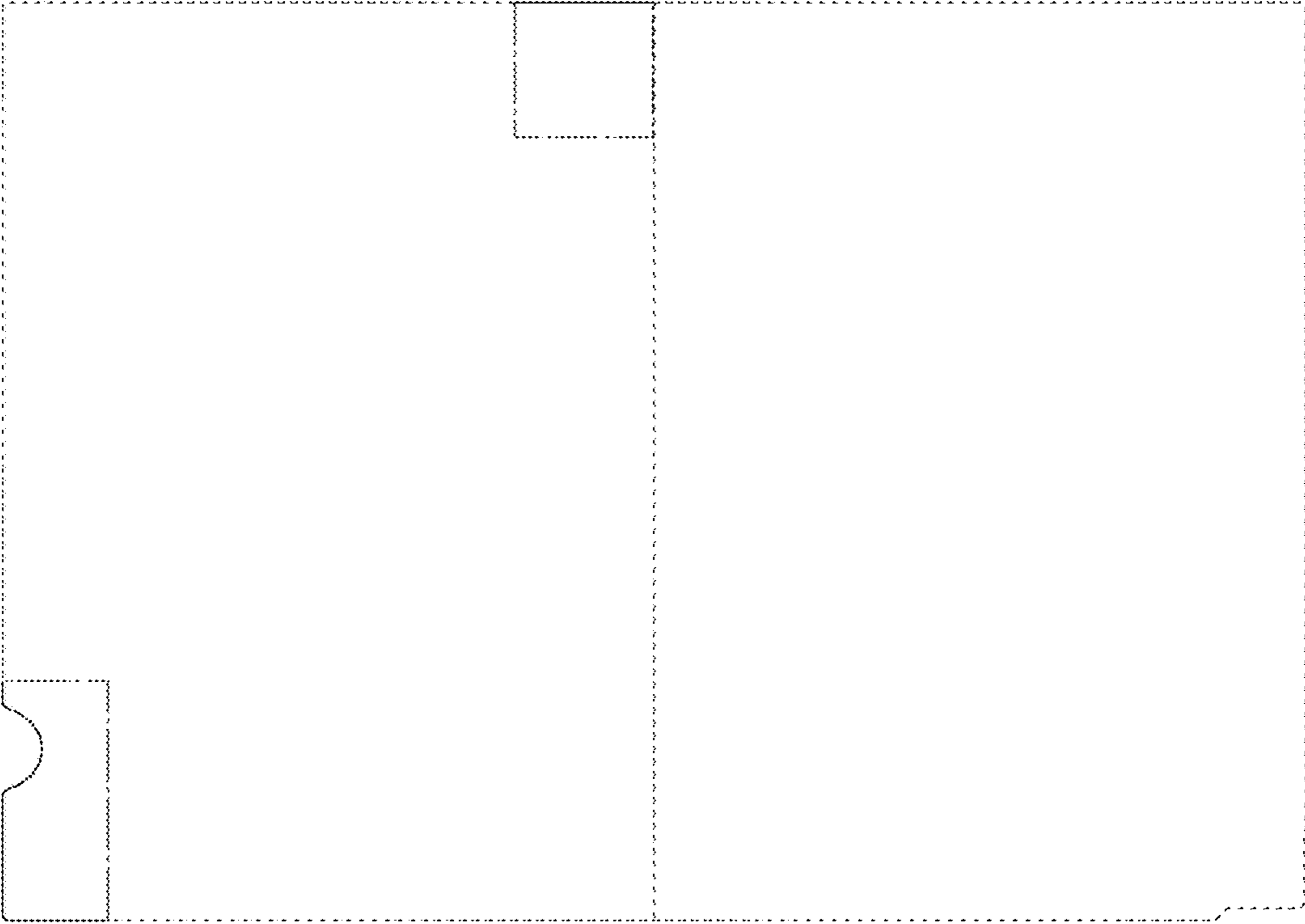

**1.4**

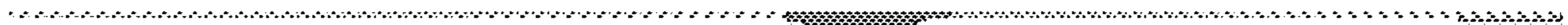

**1.5**

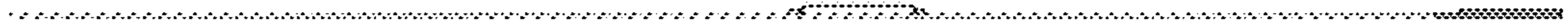

**1.6**





1.7

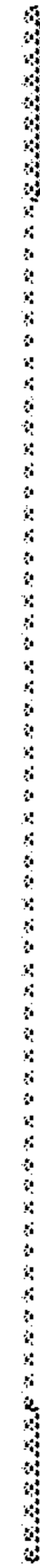

1.8

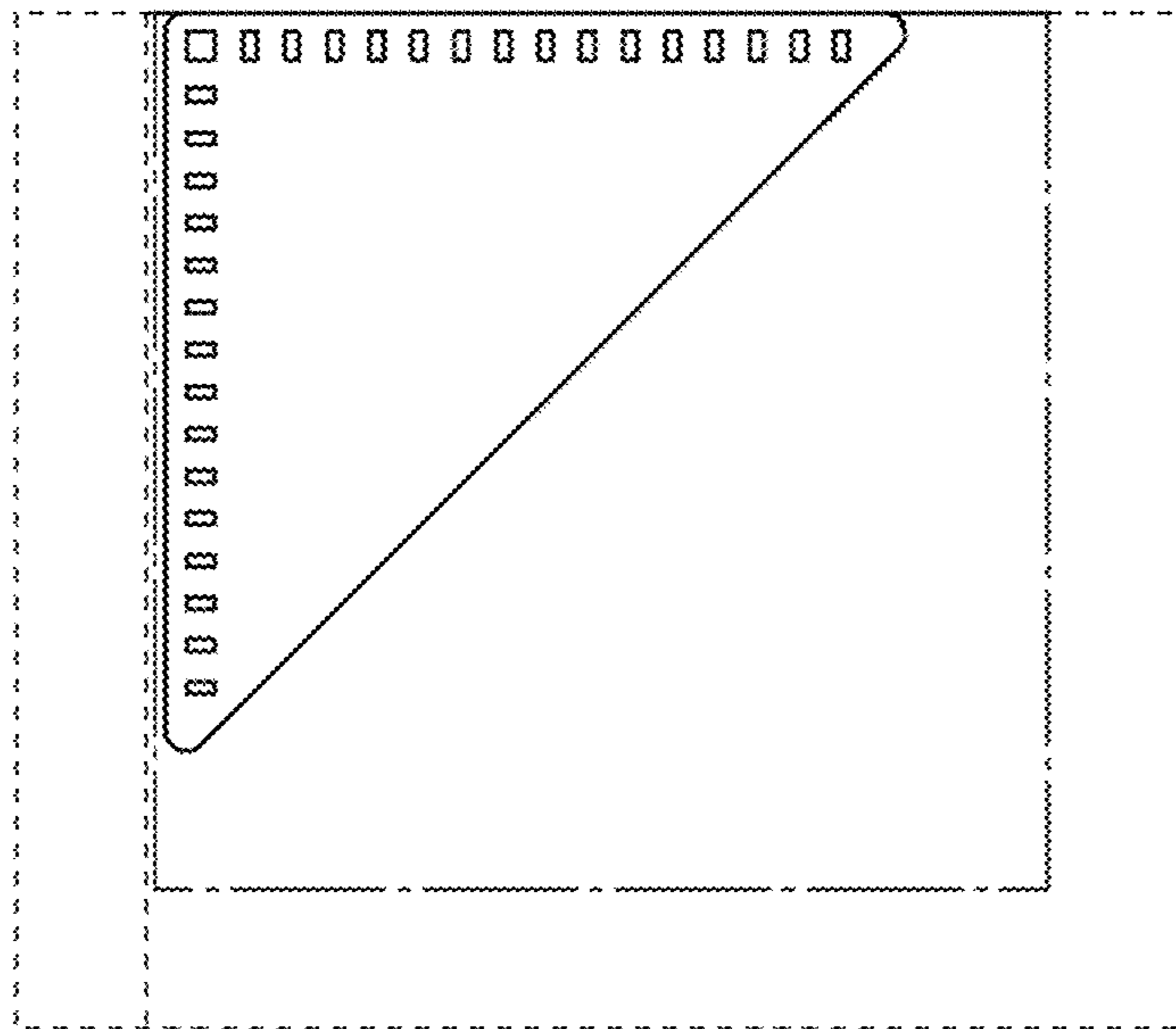

1.9

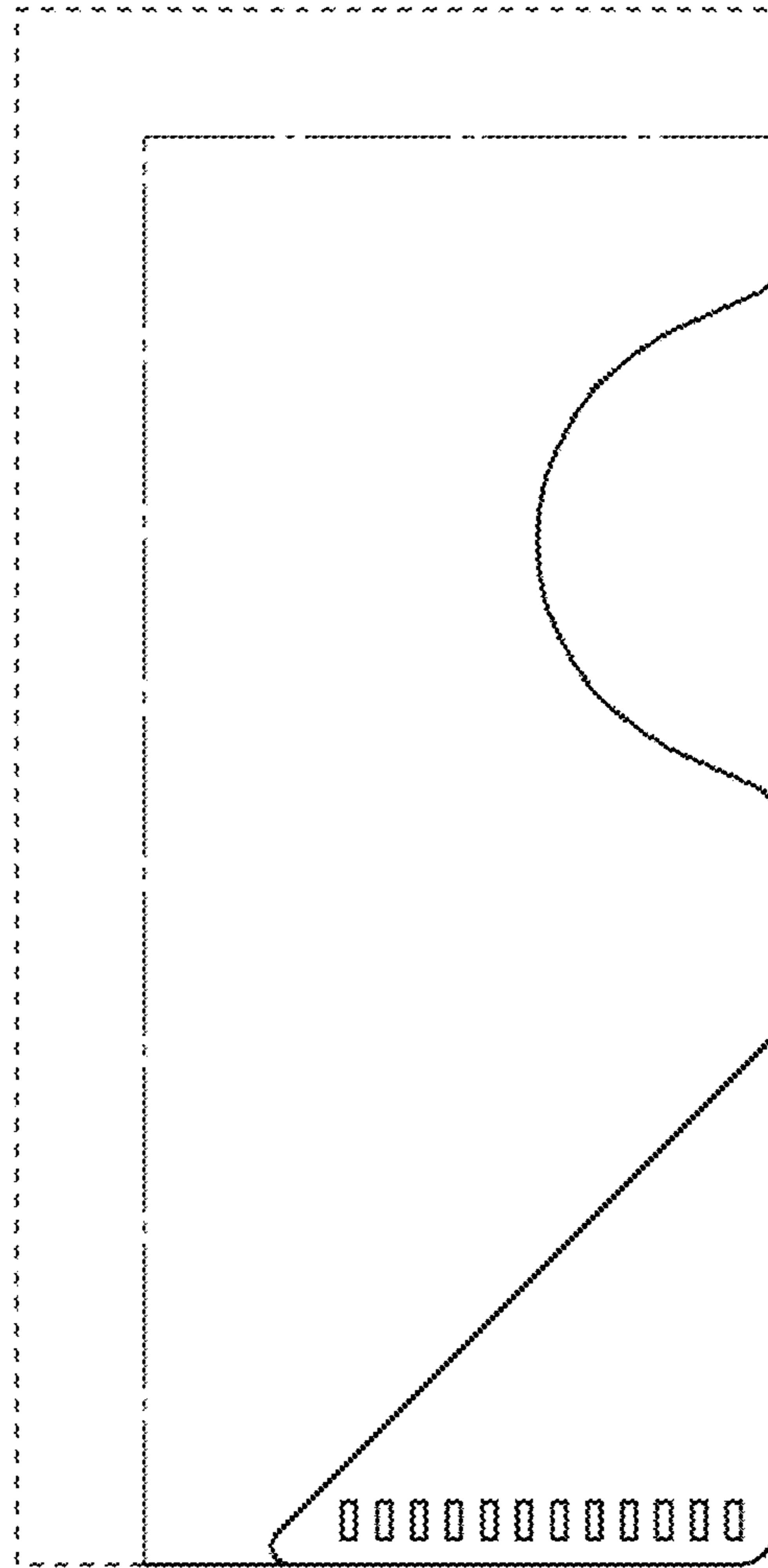

1.10



1.11

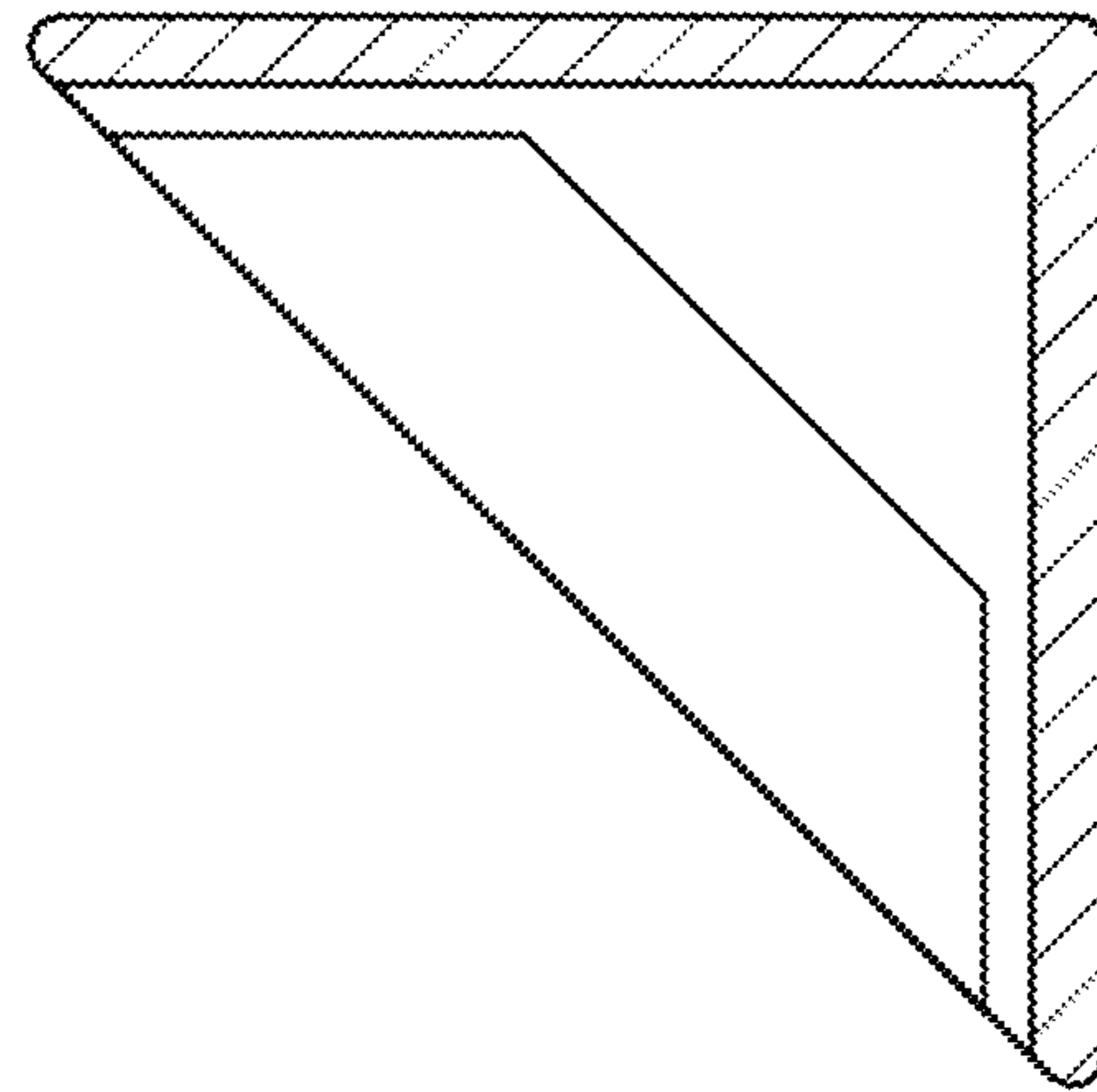

1.12

