



US00D979456S

(12) **United States Design Patent** (10) **Patent No.:** **US D979,456 S**
Lee (45) **Date of Patent:** **** Feb. 28, 2023**

(54) **ELECTRIC VEHICLE**
(71) Applicant: **Alpha Motor Corporation**, Irvine, CA (US)
(72) Inventor: **Edward Lee**, Irvine, CA (US)
(**) Term: **15 Years**
(21) Appl. No.: **29/767,053**
(22) Filed: **Jan. 20, 2021**
(51) **LOC (14) Cl.** **12-08**
(52) **U.S. Cl.**
USPC **D12/92**
(58) **Field of Classification Search**
USPC D12/86, 90-92, 88, 164; D21/424, 433,
D21/434, 533-535; 296/181.1-181.5,
296/183.1
CPC B62D 25/00; B62D 25/06; B62D 33/00;
B62D 35/00
See application file for complete search history.

D755,080 S * 5/2016 Vardis D12/92
D823,726 S * 7/2018 Hubers D12/92
D962,124 S * 8/2022 Thorp D12/92

* cited by examiner

Primary Examiner — Melody N Brown
(74) *Attorney, Agent, or Firm* — Fei Hung Yang

(57) **CLAIM**

The ornamental design for an electric vehicle, as shown and described.

DESCRIPTION

FIG. 1 is a front and right side perspective view of an electric vehicle showing our new design;
FIG. 2 is a rear and right side perspective view thereof;
FIG. 3 is a front elevational view thereof;
FIG. 4 is a rear elevational view thereof;
FIG. 5 is a left side elevational view thereof;
FIG. 6 is a right side elevational view thereof;
FIG. 7 is a top plan view thereof;
FIG. 8 is an exploded top, front and right side perspective view thereof;
FIG. 9 is an exploded rear and right side perspective view thereof; and,
FIG. 10 is an exploded right side elevational view thereof.
The portions of the electric vehicle shown in broken lines represent unclaimed subject matter that form no part of the claimed design.

(56) **References Cited**

U.S. PATENT DOCUMENTS

D231,672 S * 5/1974 Boano D12/91
D246,237 S * 11/1977 Murrill D12/92
D257,834 S * 1/1981 Giugiaro D12/92
D276,600 S * 12/1984 Nakano D12/92
D552,514 S * 10/2007 Castiglione D12/92
D622,183 S * 8/2010 Ishikura D12/90
D658,546 S * 5/2012 Abdallah D12/92
D658,547 S * 5/2012 Abdallah D12/92

1 Claim, 6 Drawing Sheets

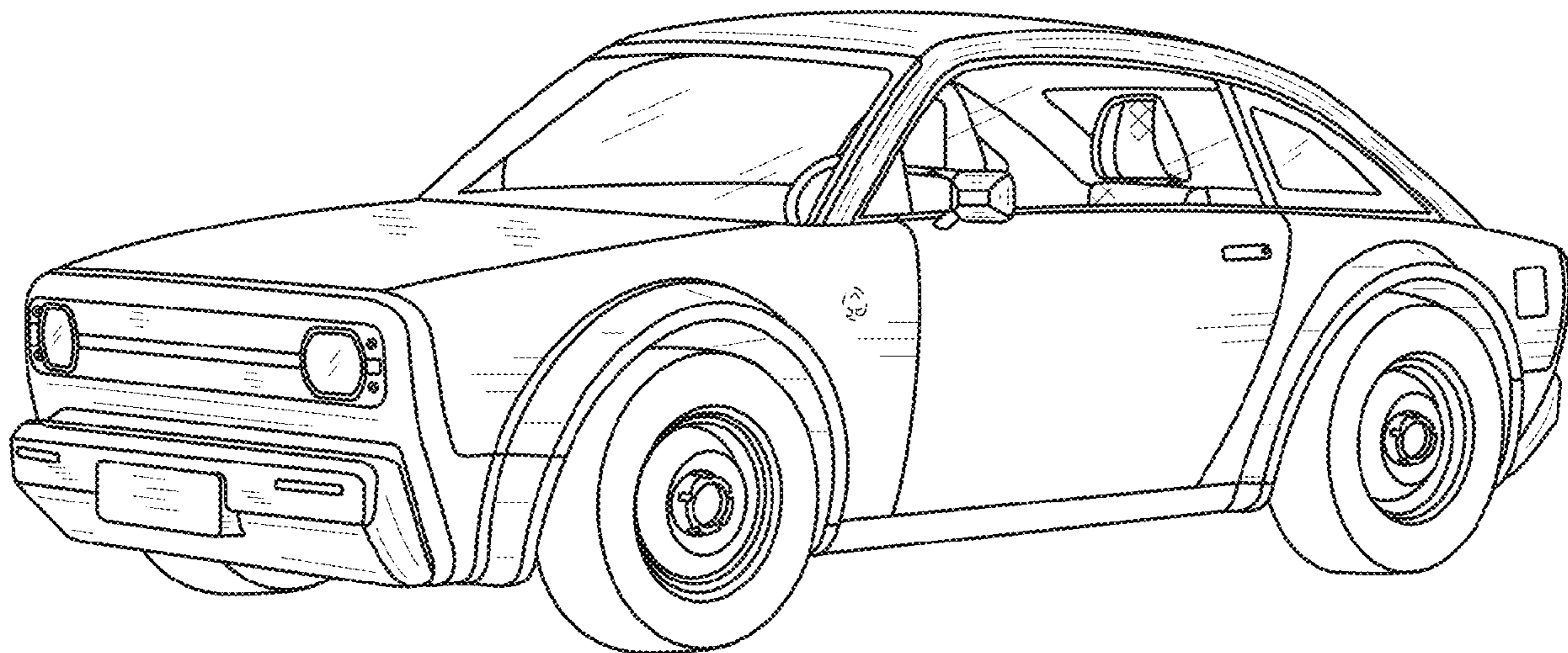

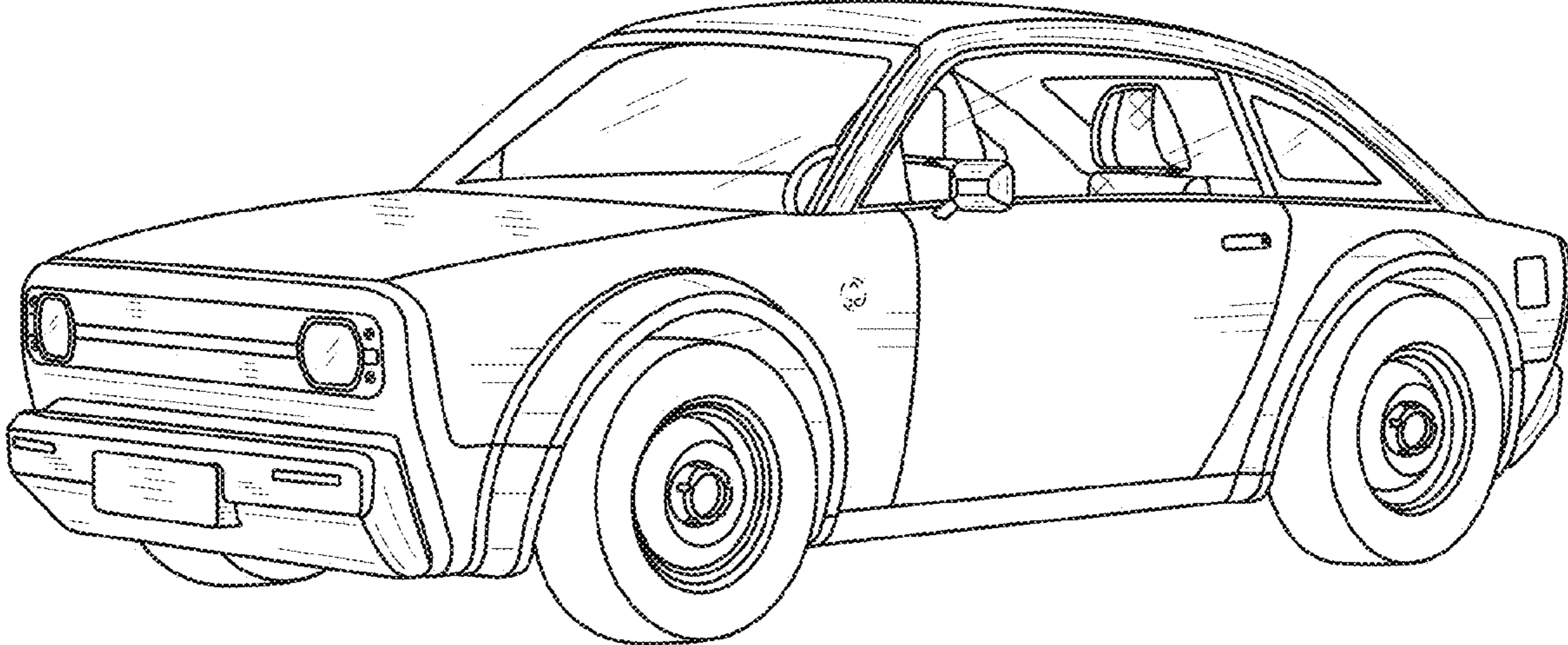

FIG. 1

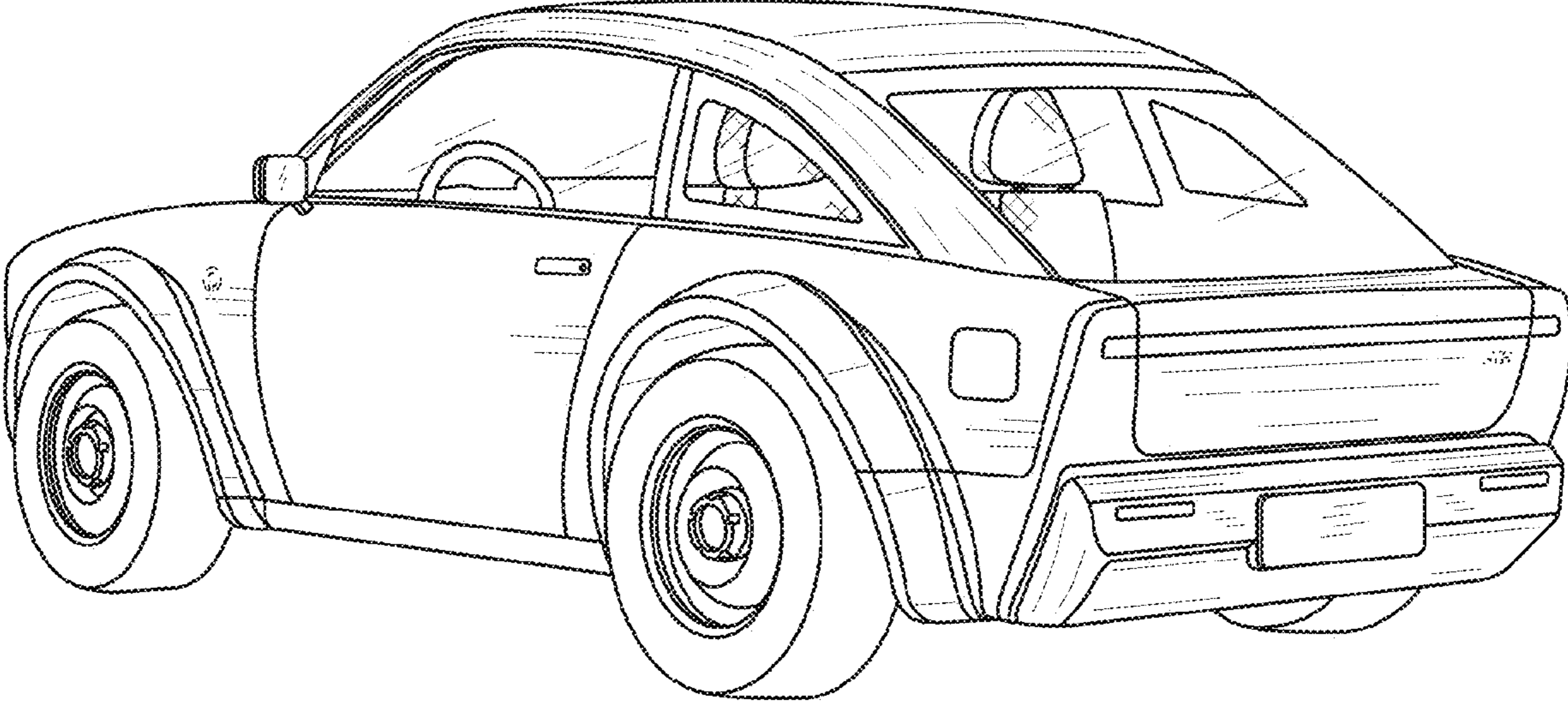

FIG. 2

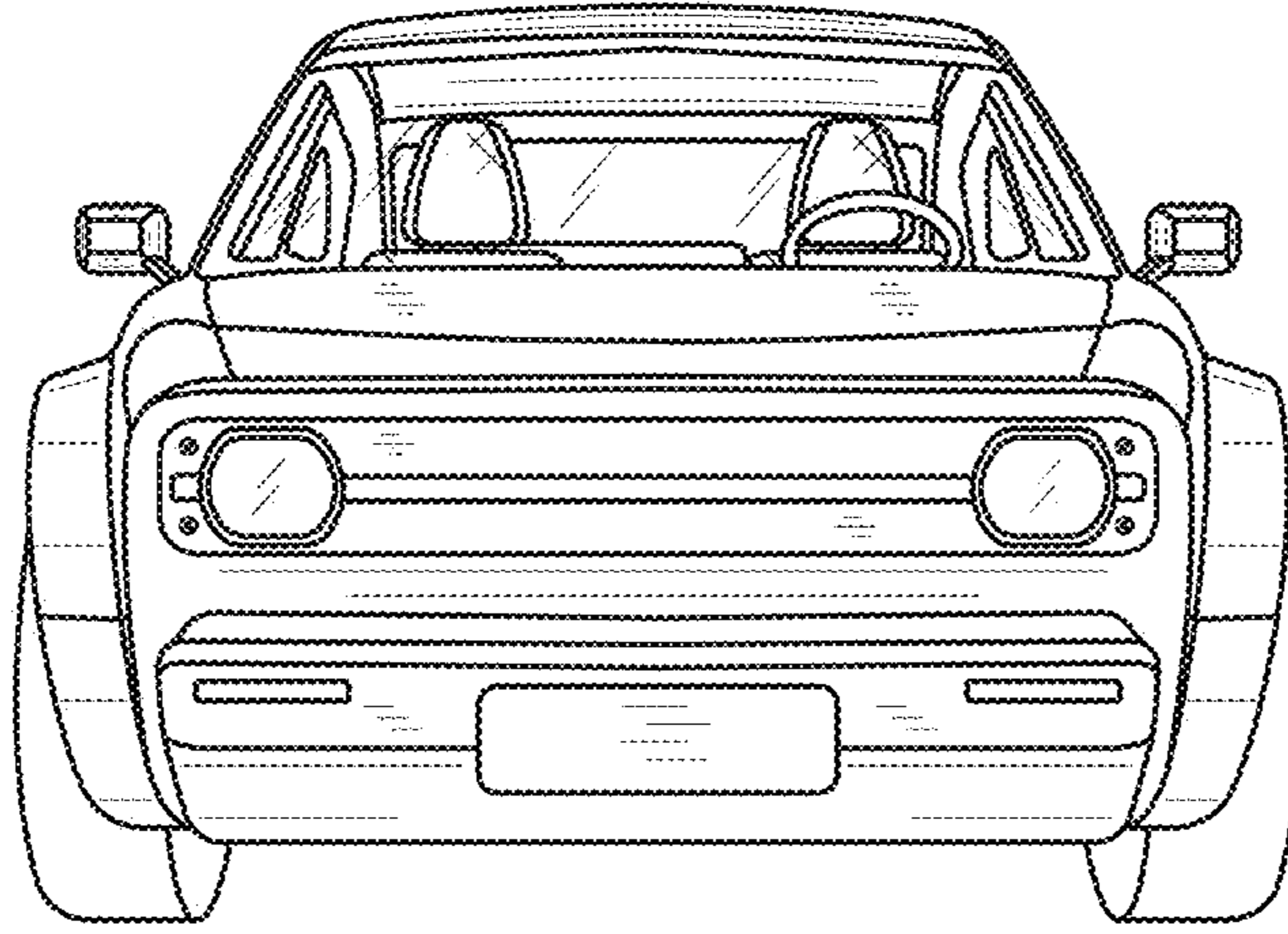

FIG. 3

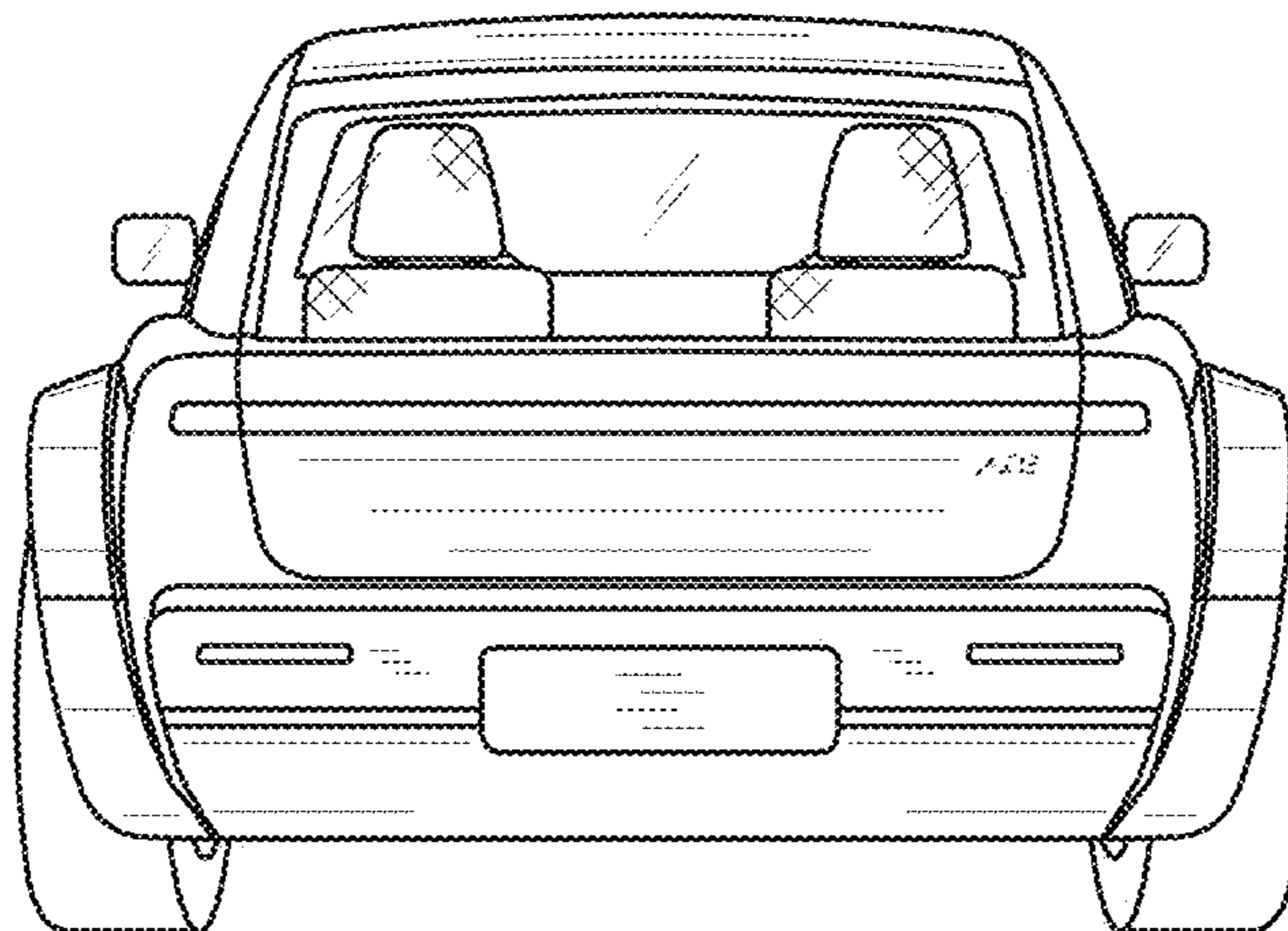

FIG. 4

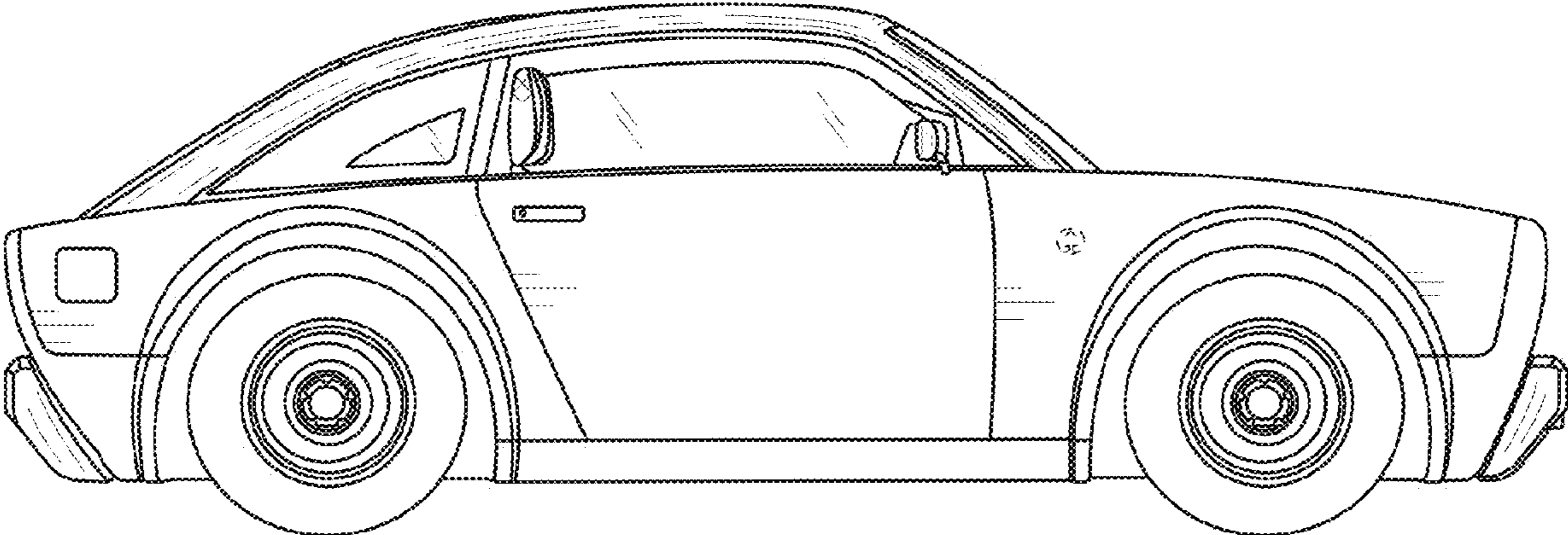

FIG. 5

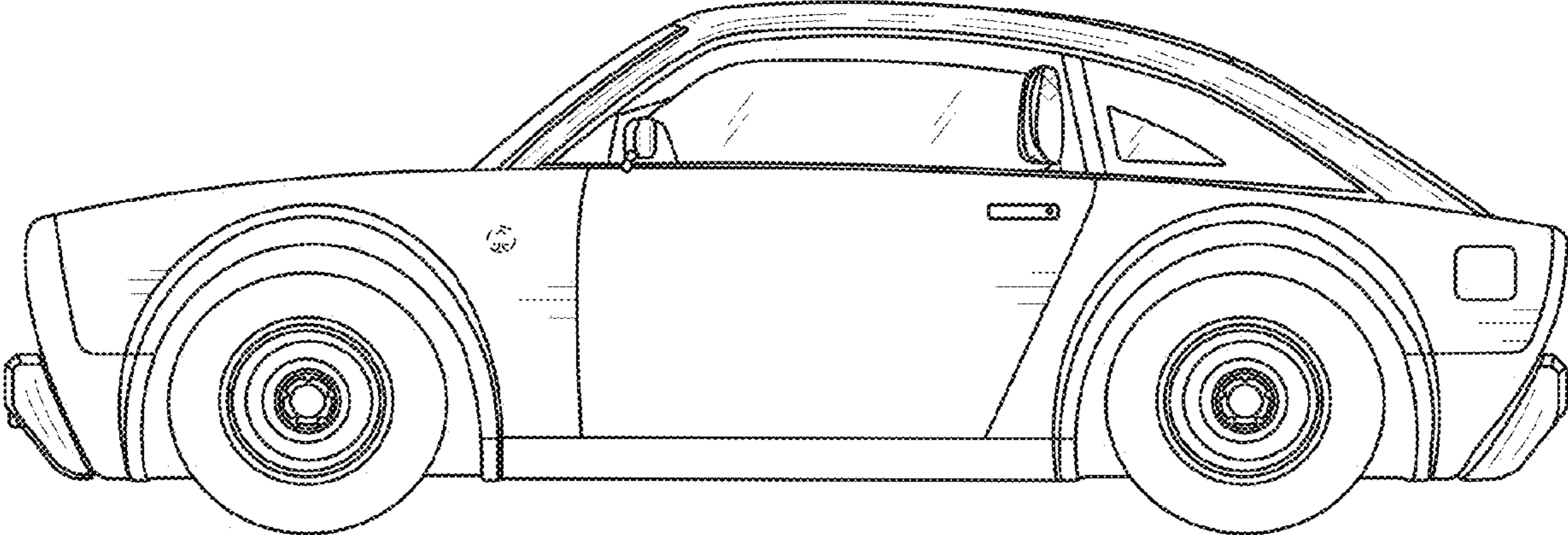

FIG. 6

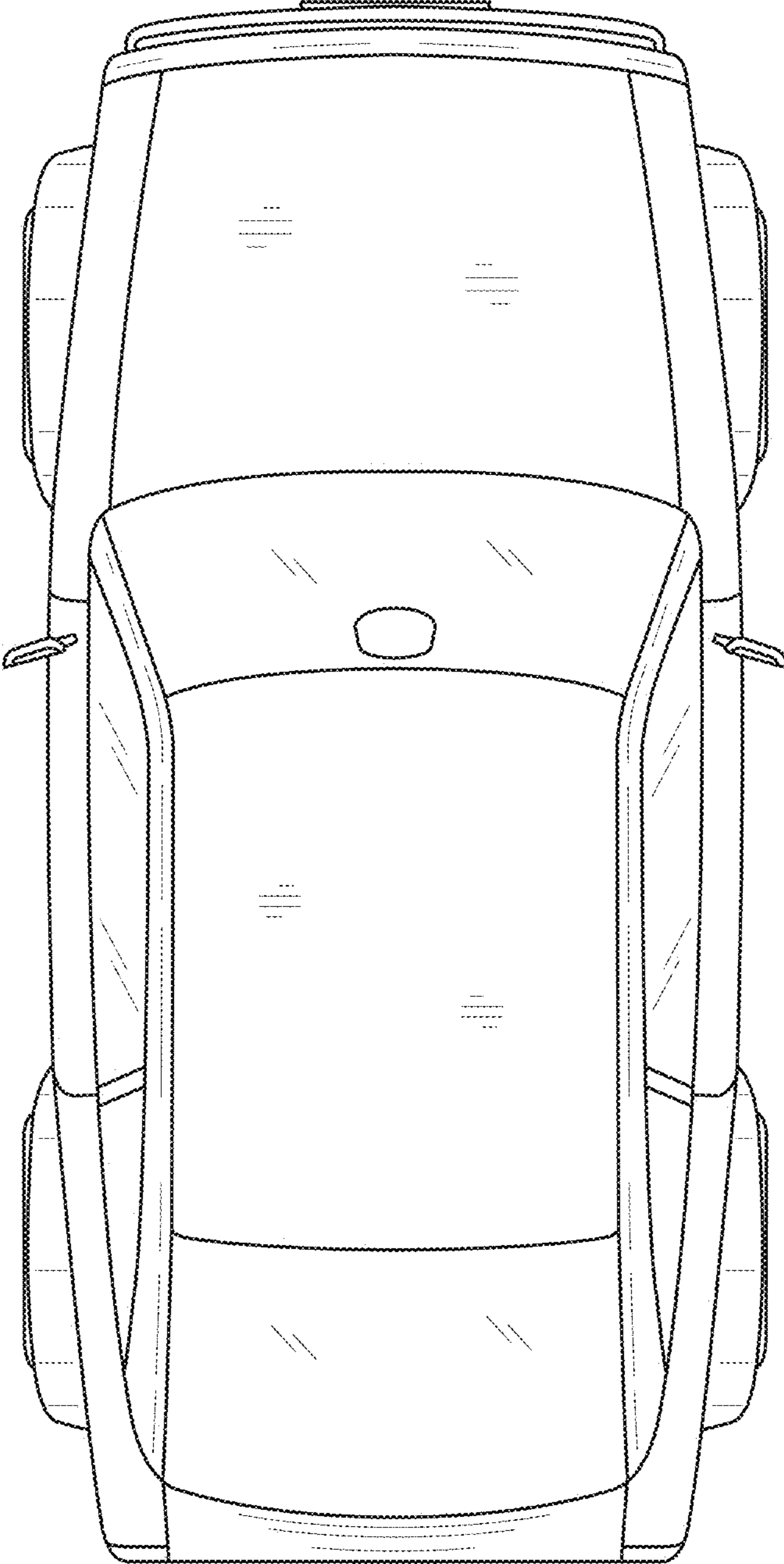

FIG. 7

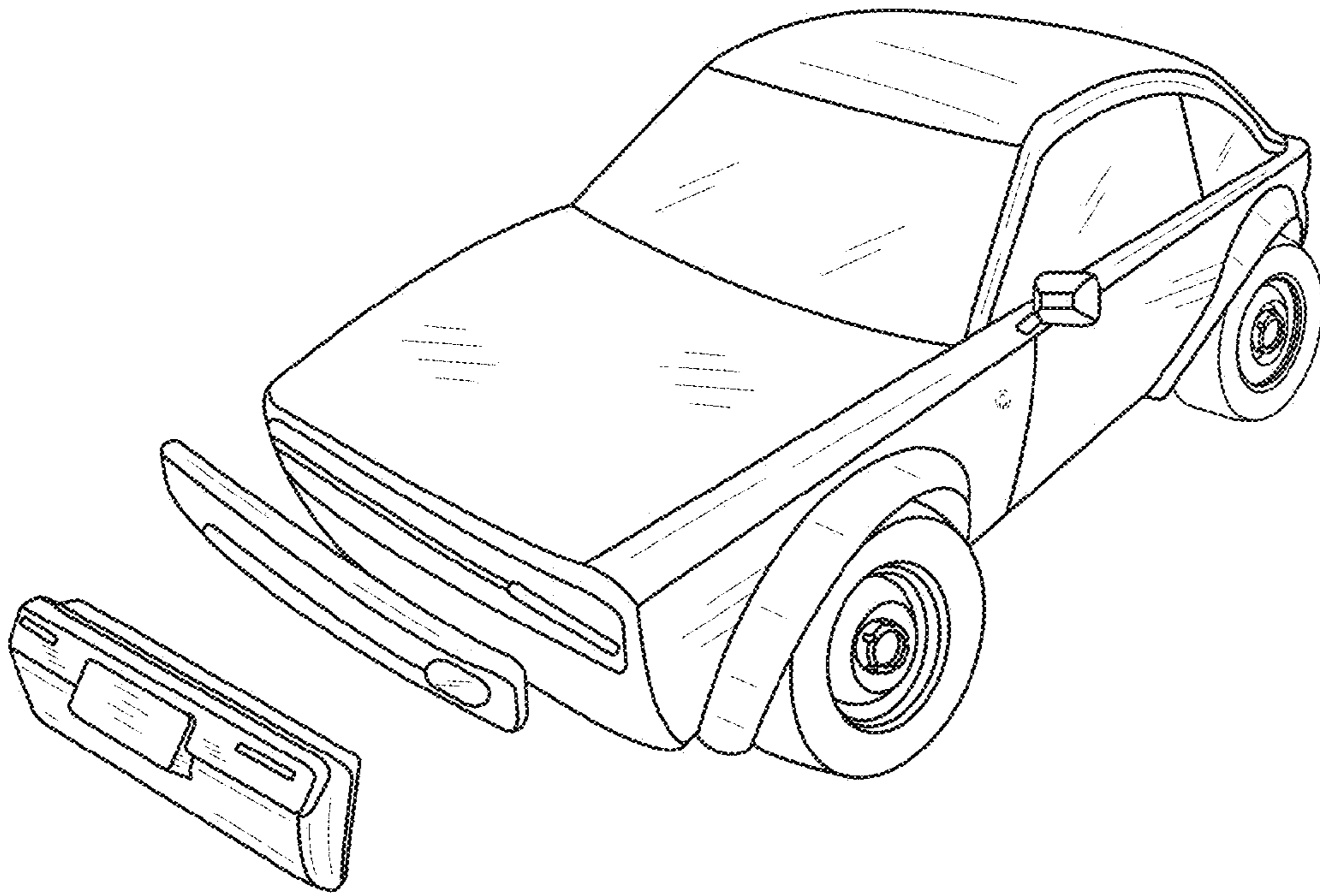

FIG. 8

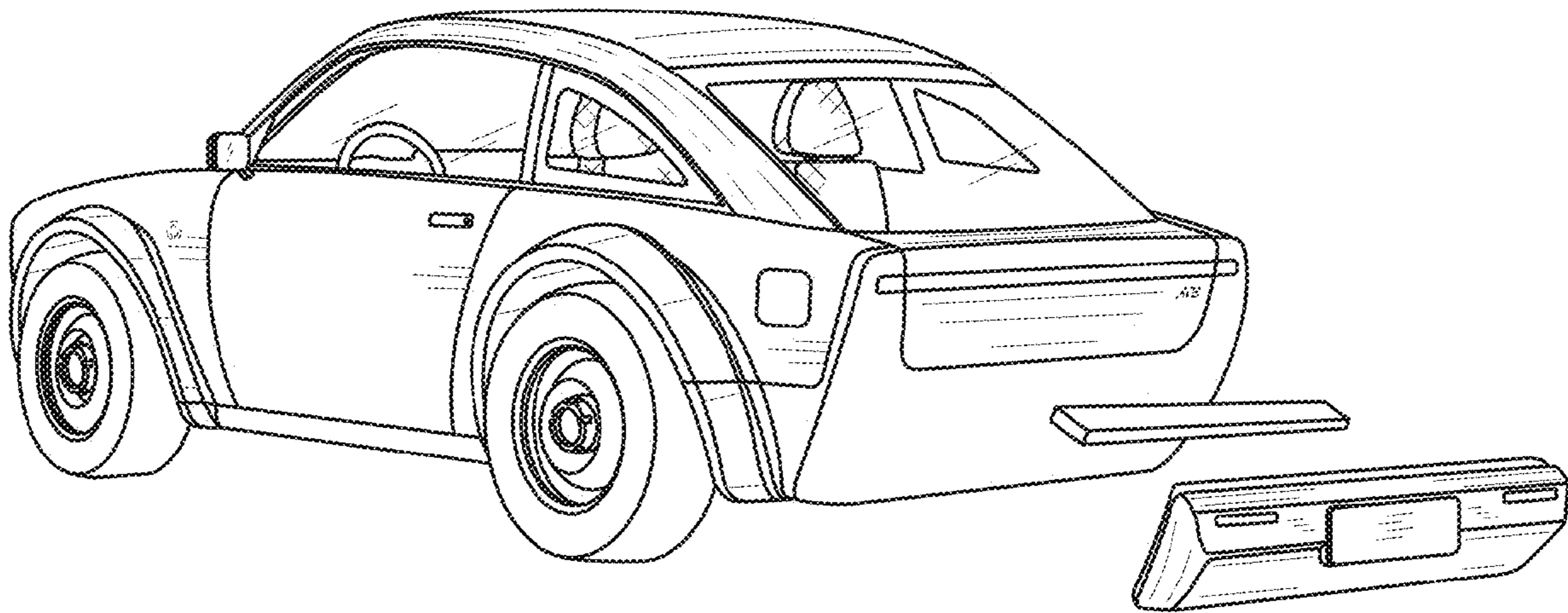

FIG. 9

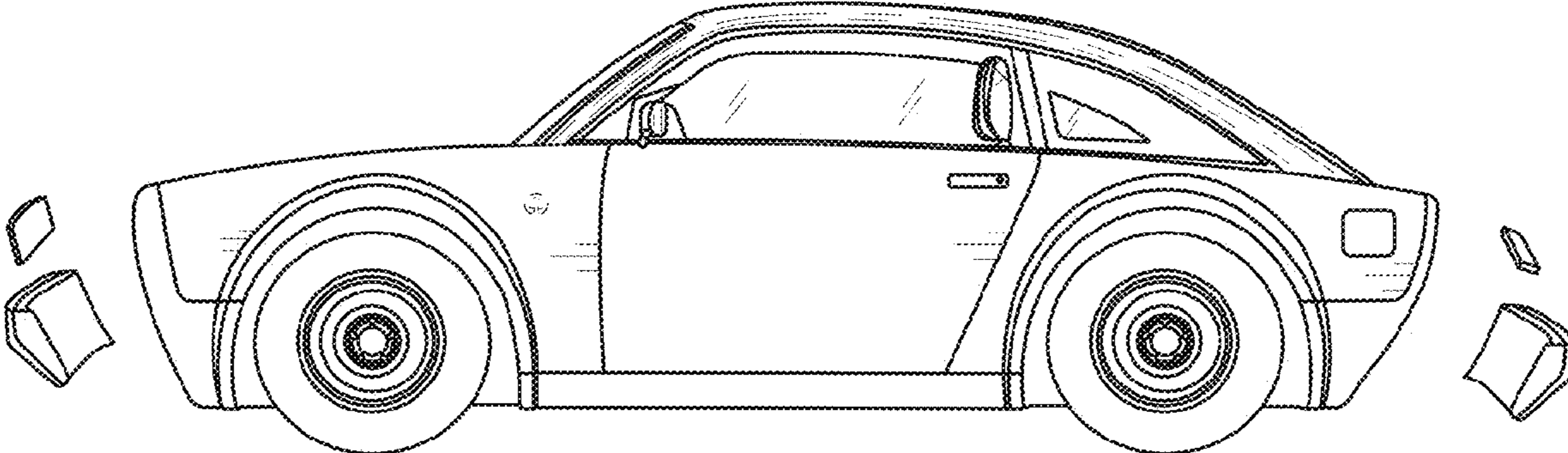

FIG. 10