



US00D979228S

(12) **United States Design Patent**
Zhang

(10) **Patent No.:** **US D979,228 S**

(45) **Date of Patent:** **** Feb. 28, 2023**

(54) **PICNIC BACKPACK**

FOREIGN PATENT DOCUMENTS

(71) Applicant: **Hui Zhang**, Shandong (CN)

CN 306652116 * 7/2021
CN 306975709 * 12/2021

(72) Inventor: **Hui Zhang**, Shandong (CN)

(Continued)

(*) Notice: Patent file contains an affidavit/declaration under 37 CFR 1.130(b).

OTHER PUBLICATIONS

(**) Term: **15 Years**

Wickerland Picnic Backpack, available at amazon.com, earliest date available Aug. 26, 2021 [online], site visited Aug. 17, 2022, available from the internet URL: <https://www.amazon.com/Backpack-Insulated-Waterproof-Blanket-Cutlery/dp/B09DY9WDHC/> (Year: 2021).*

(21) Appl. No.: **29/838,936**

(Continued)

(22) Filed: **May 17, 2022**

(51) **LOC (14) Cl.** **03-01**

(52) **U.S. Cl.**
USPC **D3/217**

Primary Examiner — April Rivas
Assistant Examiner — Jillian Mazzola

(58) **Field of Classification Search**
USPC D3/213–217, 221, 224–233, 242–244,
D3/254–262

(57) **CLAIM**

CPC A45F 3/00; A45F 3/005; A45F 3/02; A45F 3/04; A45F 3/042; A45F 3/047; A45F 3/06; A45F 3/08; A45F 3/10; A45F 2003/001; A45F 2003/002; A45F 2003/003; A45F 2003/006; A45F 2003/007; A45F 2003/008; A45F 2003/025; A45F 2003/045; A45F 2200/00; A45F 2200/05; A45F 2200/0525; A45F 2200/0533

The ornamental design for a picnic backpack, as shown and described.

See application file for complete search history.

DESCRIPTION

(56) **References Cited**

U.S. PATENT DOCUMENTS

D333,038 S * 2/1993 Collins D3/254
D392,798 S * 3/1998 Gelb D3/217
D400,353 S * 11/1998 Callanan D3/254
D409,376 S * 5/1999 Golenz D3/217
D413,201 S * 8/1999 Tavernier D3/261
D505,258 S * 5/2005 Bird D3/217
D506,864 S * 7/2005 Fonfeder D3/217
D574,613 S * 8/2008 Gerbi D3/246

FIG. 1 is a front and top perspective view of a picnic backpack, showing my new design;
FIG. 2 is a rear and bottom perspective view thereof;
FIG. 3 is a front elevation view thereof;
FIG. 4 is a rear elevation view thereof;
FIG. 5 is a left side elevation view thereof;
FIG. 6 is a right side elevation view thereof;
FIG. 7 is a top plan view thereof;
FIG. 8 is a bottom plan view thereof;
FIG. 9 is an enlarged view of a portion of the picnic backpack indicated with numeric 9 in FIG. 1; and,
FIG. 10 is an enlarged view of a portion of the picnic backpack indicated with numeric 10 in FIG. 1.

The broken lines in the figures illustrate portions of the picnic backpack that form no part of the claimed design. The dash dot dash lines in FIGS. 1, 9 and 10 are for the purpose of depicting the cut line of the enlarged views and form no part of the claim.

(Continued)

1 Claim, 10 Drawing Sheets

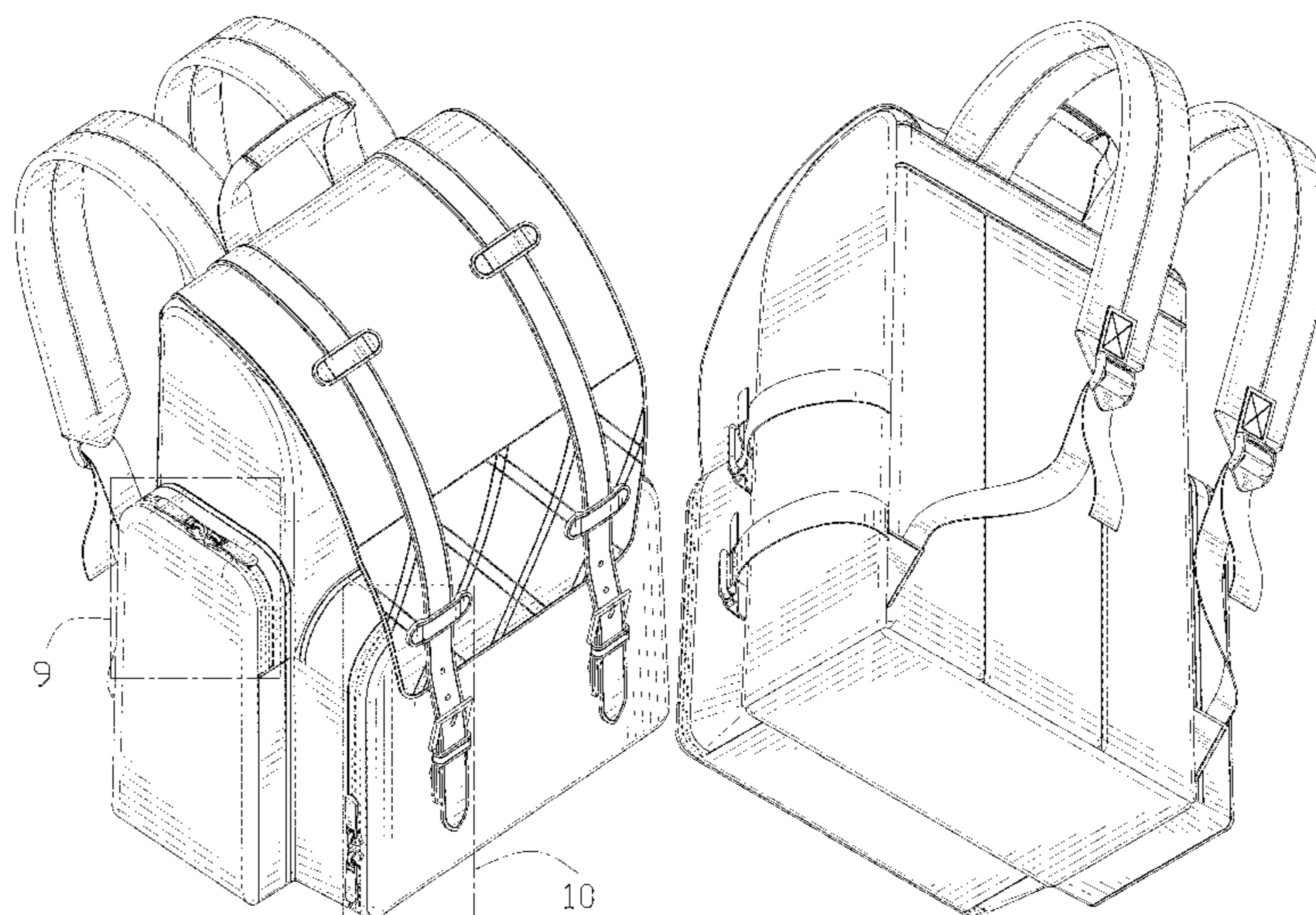

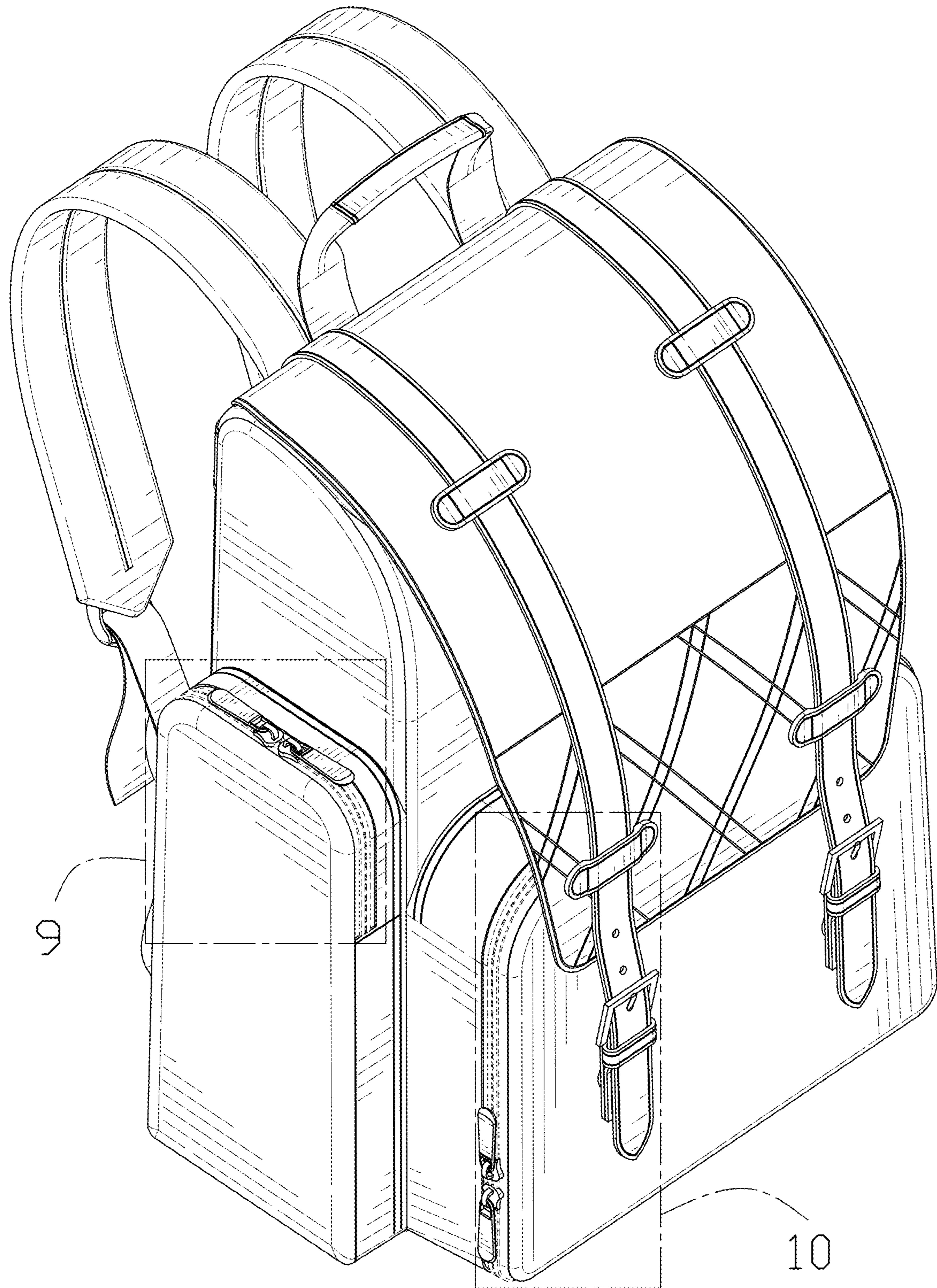

FIG. 1

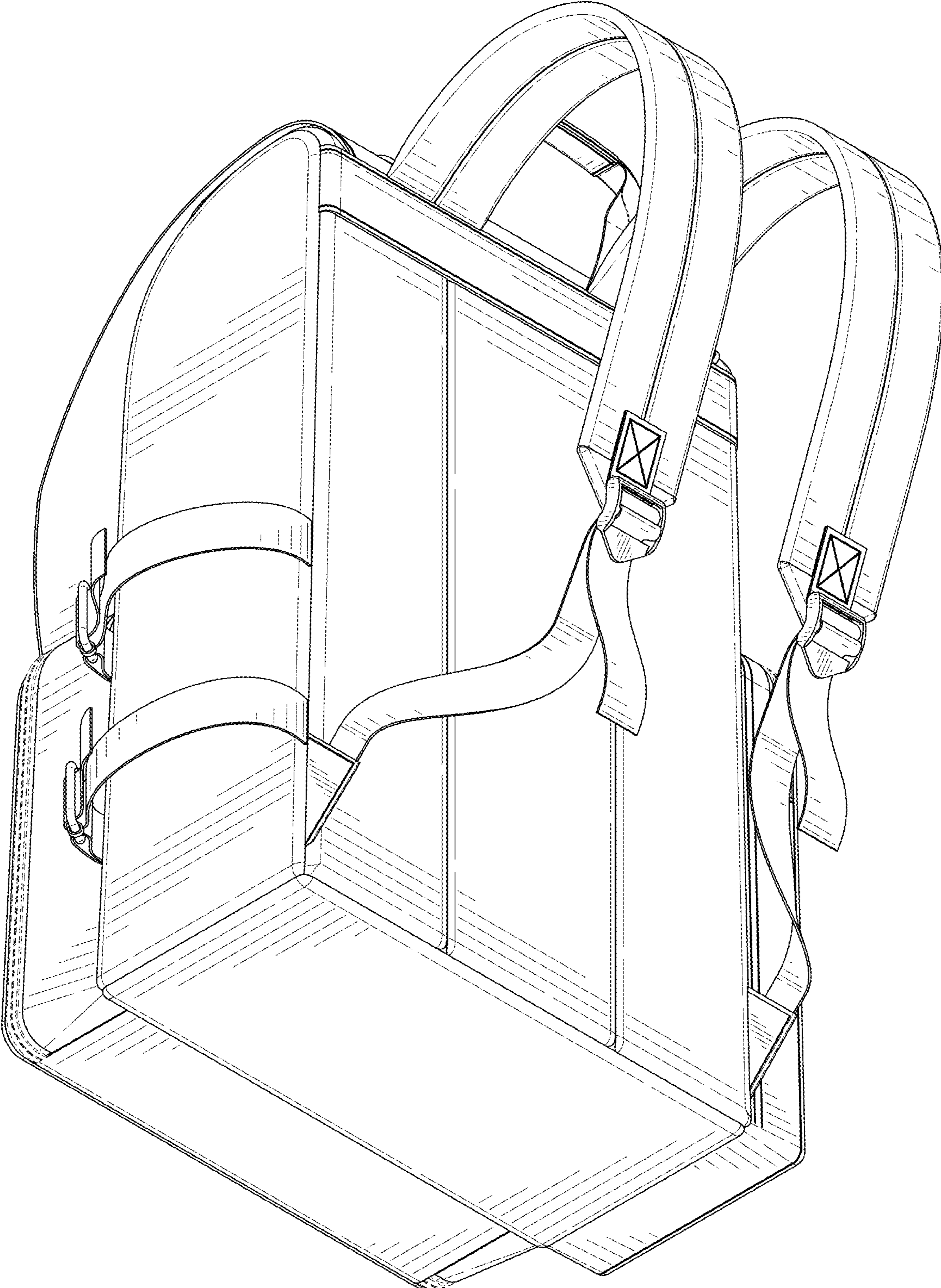

FIG. 2

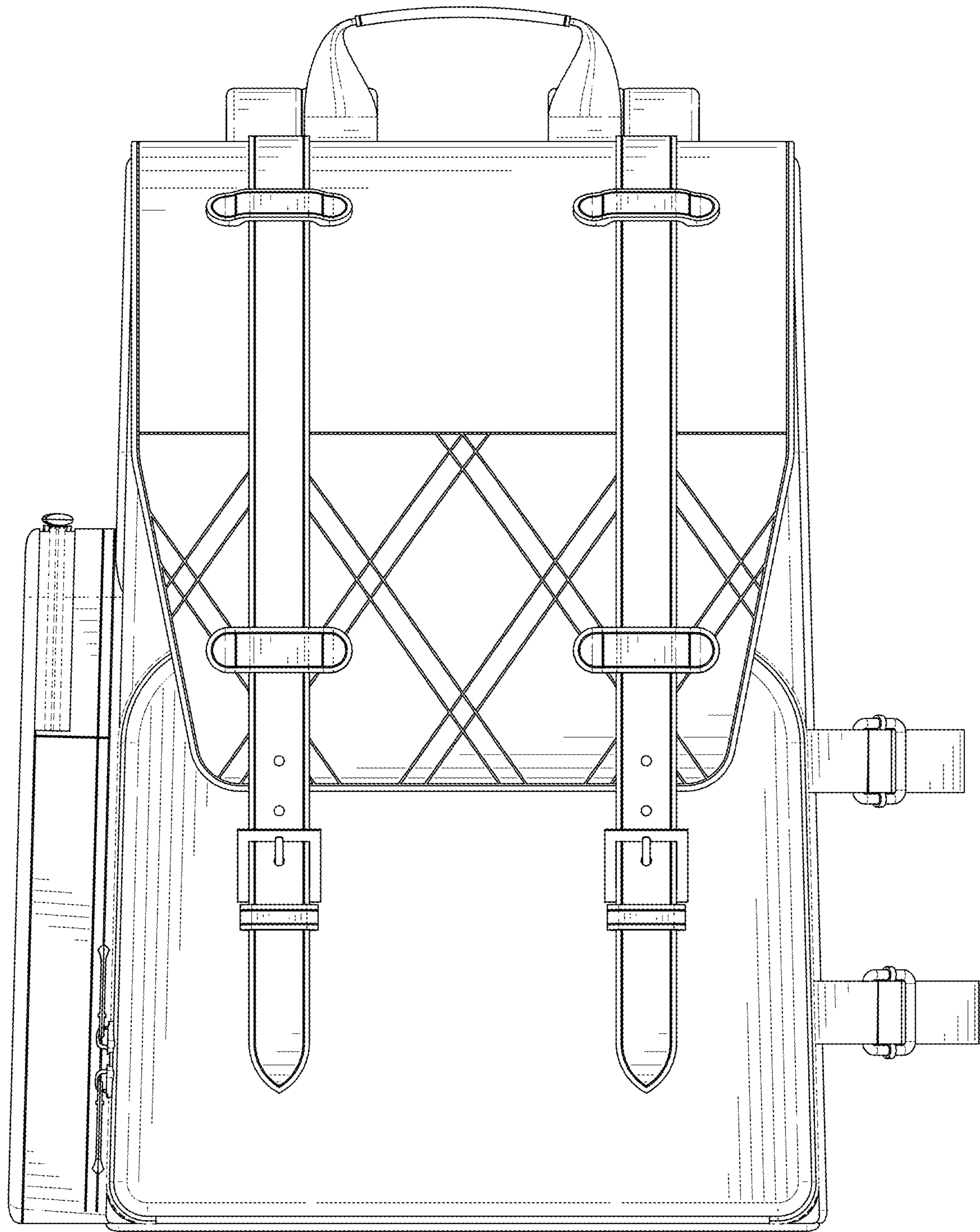

FIG. 3

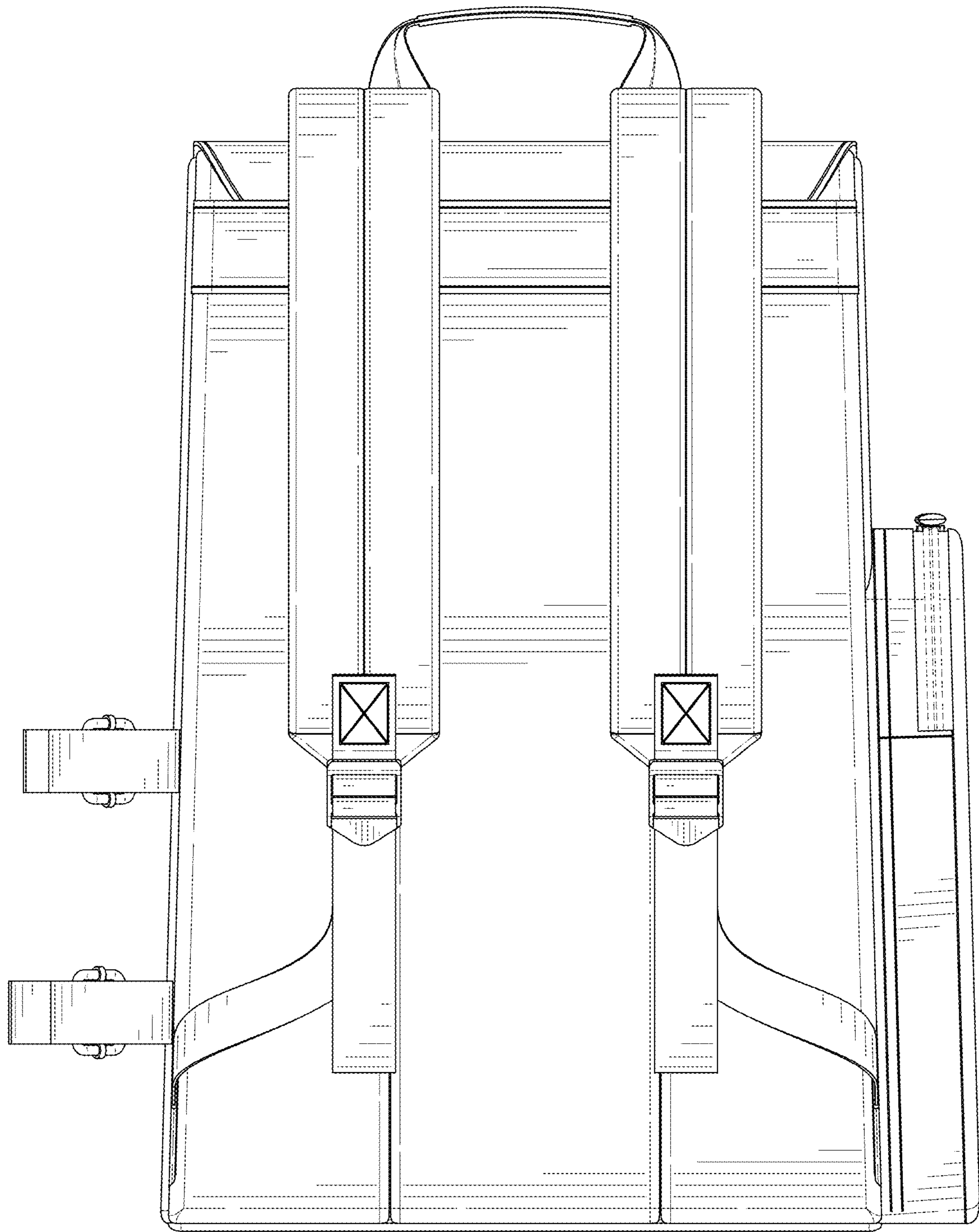

FIG. 4

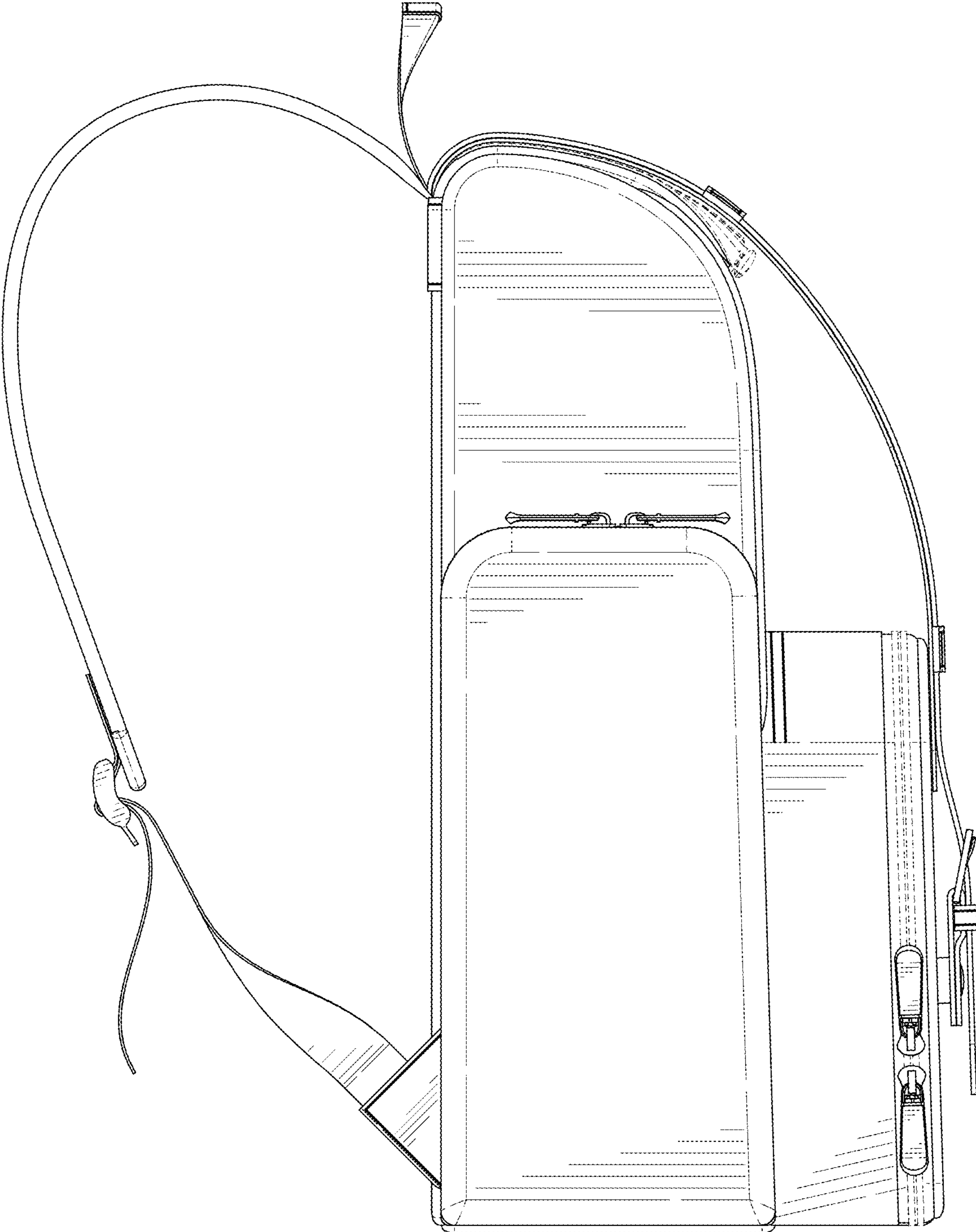

FIG. 5

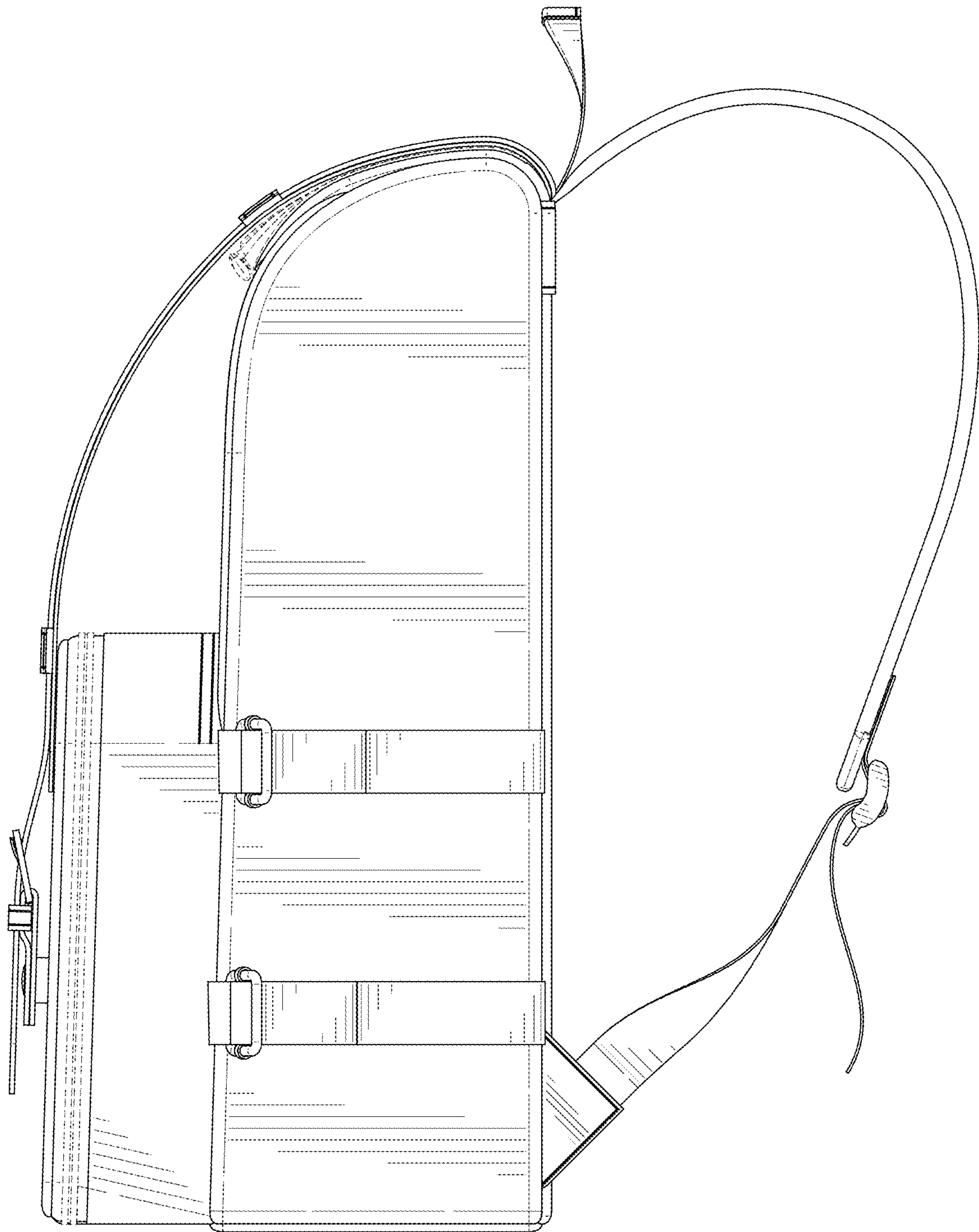

FIG. 6

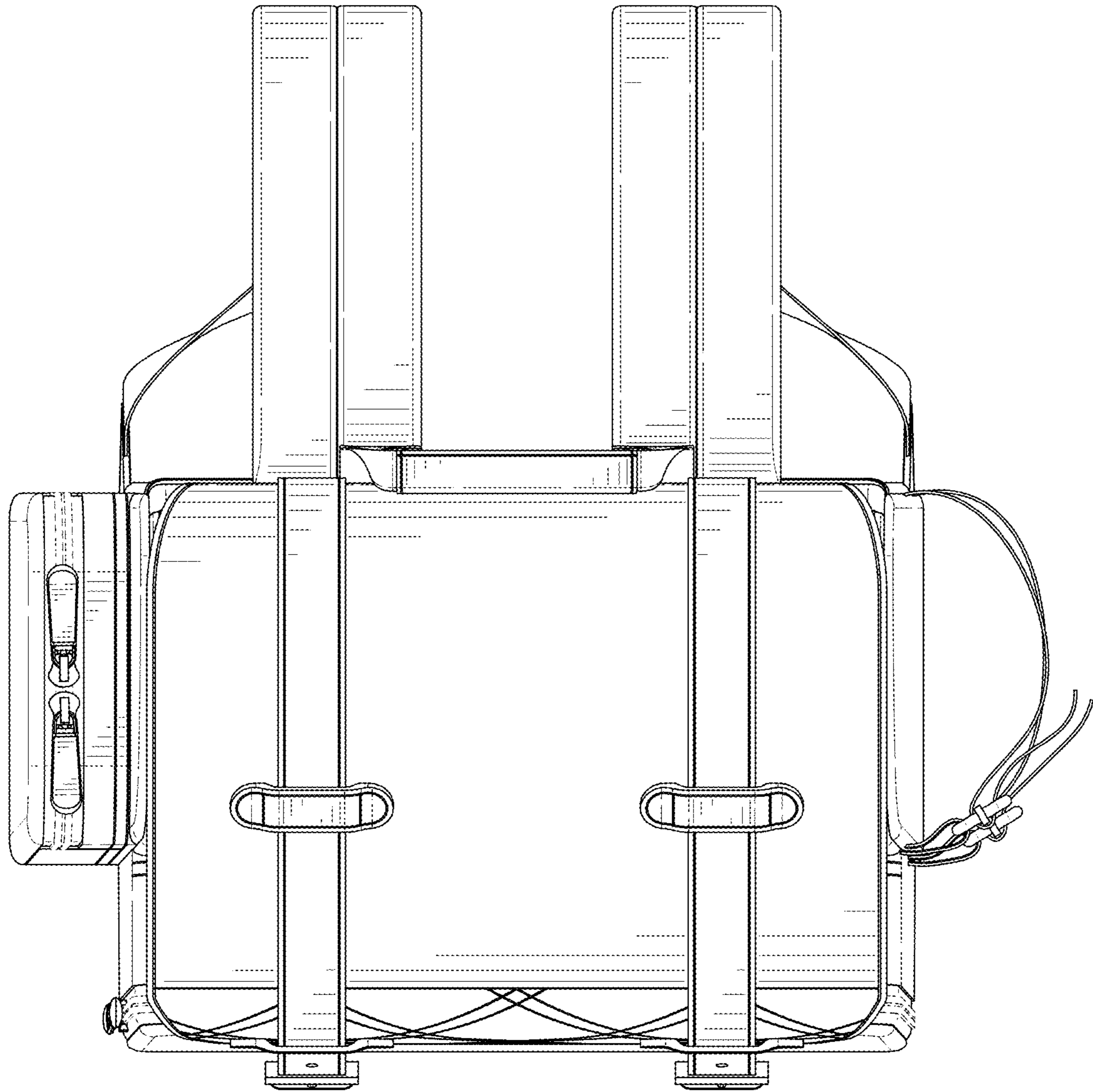

FIG. 7

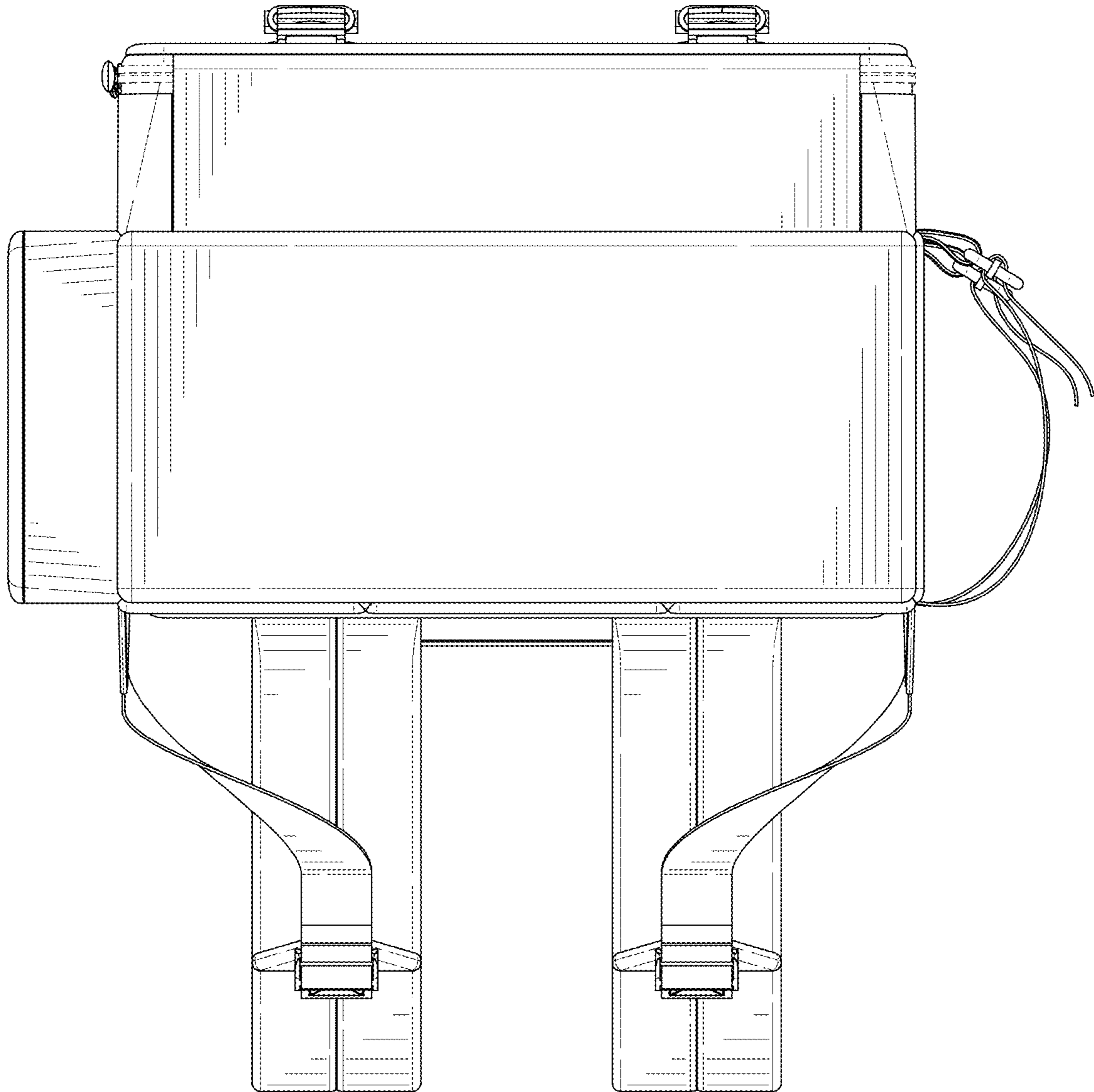

FIG. 8



FIG. 9

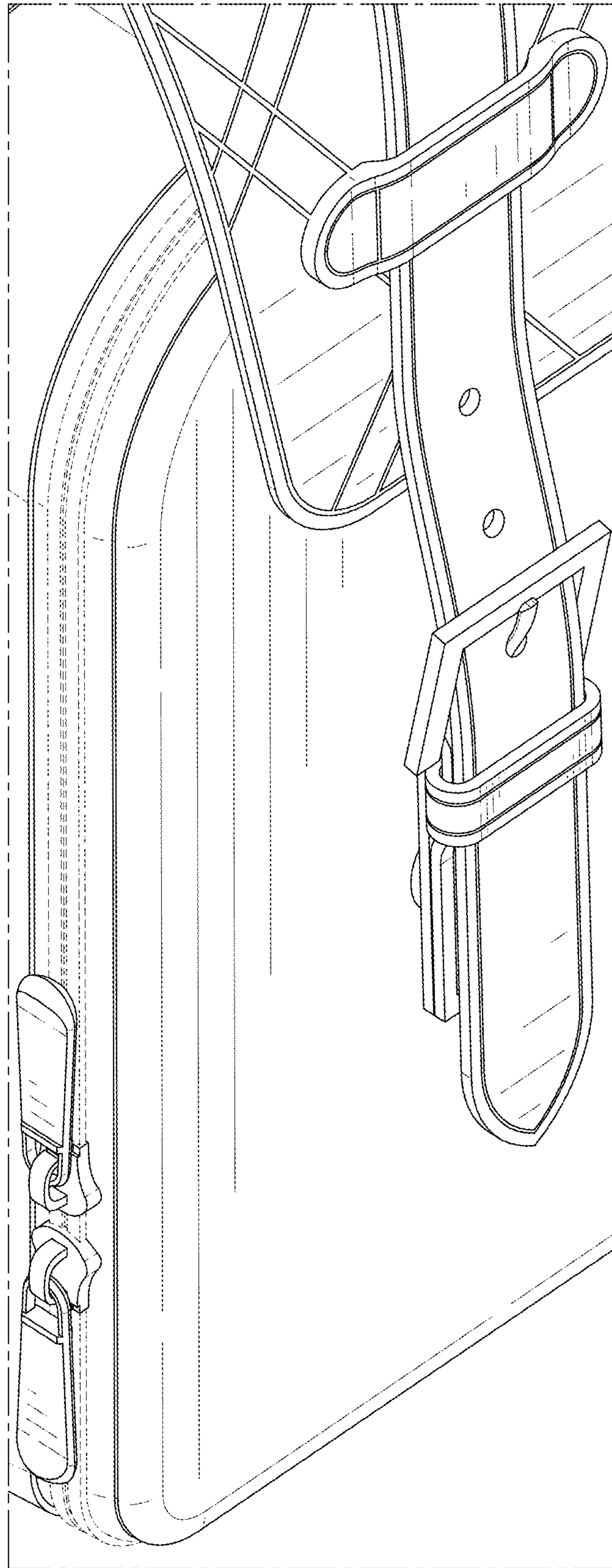

FIG. 10