



US00D978731S

(12) **United States Design Patent**  
**Kupitza**

(10) **Patent No.:** **US D978,731 S**

(45) **Date of Patent:** **\*\* Feb. 21, 2023**

- (54) **MOTOR TRUCK CAB WALL PANEL**
- (71) Applicant: **Man Truck & Bus SE**, Munich (DE)
- (72) Inventor: **Rudolf Kupitza**, Munich (DE)
- (73) Assignee: **MAN TRUCK & BUS SE**, Munich (DE)

- D416,829 S 11/1999 Sacco et al.
- D422,944 S 4/2000 Hellhake et al.
- D425,826 S 5/2000 Hellhake et al.
- D442,519 S \* 5/2001 Sacco ..... D12/96
- 6,230,832 B1 5/2001 von Mayenburg et al.
- D540,218 S \* 4/2007 Sekiguchi ..... D12/96

(Continued)

- (\*\*) Term: **15 Years**
- (21) Appl. No.: **29/807,528**
- (22) Filed: **Sep. 13, 2021**

**OTHER PUBLICATIONS**

“Simplifying Business.” Man Truckbus Asia., May 27, 2020 [online], [retrieved on Oct. 9, 2022]. Retrieved from the Internet <URL: <http://www.man-truckbus-asia.com/pdf/Company%20Profile%20MAN.pdf>>.\*

(Continued)

**Related U.S. Application Data**

- (62) Division of application No. 35/509,887, filed on Nov. 26, 2019 (U.S. filing date under 35 U.S.C. 384), and having an international filing date of Nov. 26, 2019, now Pat. No. Des. 933,532.

*Primary Examiner* — Darlington Ly  
(74) *Attorney, Agent, or Firm* — Fox Rothschild LLP

**Foreign Application Priority Data**

Jun. 6, 2019 (DE) ..... 40 2019 100 633.8

(57) **CLAIM**

The ornamental design for a motor truck cab wall panel, as shown and described.

(51) **LOC (14) Cl.** ..... **12-08**

(52) **U.S. Cl.**  
USPC ..... **D12/96; D12/84**

(58) **Field of Classification Search**  
USPC ... D12/1, 14, 15, 82, 84, 90, 93, 95, 96, 99;  
D21/433, 434, 552, 554  
CPC ..... B60Y 2200/14; B60Y 2200/141; B60Y  
2200/142; B60Y 2200/1422; B62D 33/00;  
B62D 33/06; B62D 33/077; B62D  
33/0604; B62D 33/0612

See application file for complete search history.

**DESCRIPTION**

FIG. 1 is a right side elevation view of a motor truck cab wall panel embodying my new design;  
FIG. 2 is a left side elevation view thereof;  
FIG. 3 is a right side perspective view thereof;  
FIG. 4 is a front and right side perspective view thereof;  
FIG. 5 is a front elevation view thereof;  
FIG. 6 is a rear elevation view thereof;  
FIG. 7 is a bottom and left side perspective view thereof;  
FIG. 8 is a bottom and right side perspective view thereof;  
and,  
FIG. 9 is a right perspective view thereof in the context of a motor truck.

The broken lines and ghosted or low contrasted showings of the motor truck interior are provided for the purpose of illustrating environmental structure and form no part of the claimed design.

(56) **References Cited**

**U.S. PATENT DOCUMENTS**

- 2,699,223 A 1/1955 Brumbaugh
- D276,710 S 12/1984 Brunger et al.
- 4,972,913 A 11/1990 Ray et al.

**1 Claim, 9 Drawing Sheets**

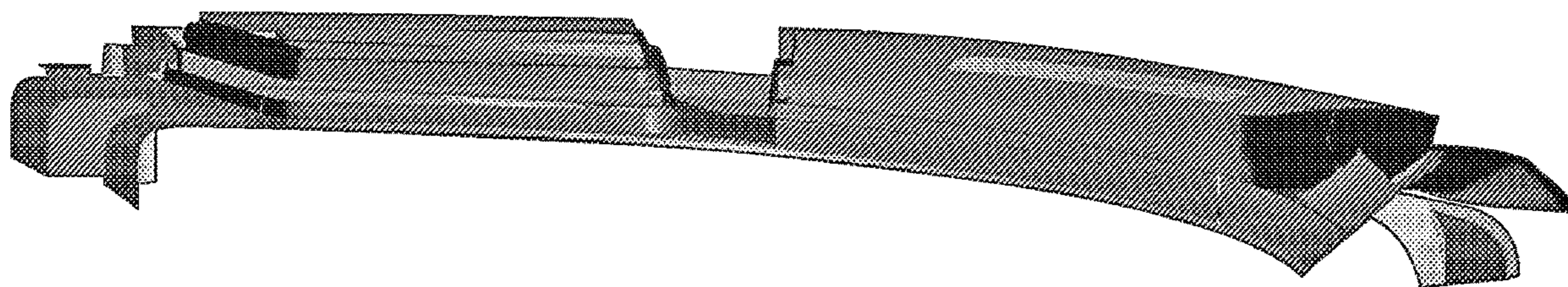

(56)

References Cited

U.S. PATENT DOCUMENTS

D540,219 S 4/2007 Oka  
 D567,885 S 4/2008 Amadio et al.  
 D570,740 S \* 6/2008 Emoto ..... D12/96  
 D571,259 S \* 6/2008 Emoto ..... D12/96  
 D619,049 S \* 7/2010 Beigel ..... D12/96  
 D623,091 S \* 9/2010 Beigel ..... D12/96  
 D623,092 S \* 9/2010 Beigel ..... D12/96  
 D632,614 S \* 2/2011 Iuchi ..... D12/96  
 D634,244 S \* 3/2011 Aris ..... D12/96  
 D642,205 S \* 7/2011 Yamamoto ..... D15/30  
 D651,136 S \* 12/2011 Stimel, Jr. .... D12/96  
 D653,994 S \* 2/2012 Fukushima ..... D12/96  
 D666,528 S \* 9/2012 Lai ..... D12/96  
 D685,294 S 7/2013 Hanson et al.  
 D687,868 S \* 8/2013 Watson ..... D15/30  
 8,590,652 B2 11/2013 Grumbo  
 D700,109 S 2/2014 Brzustowicz et al.  
 D748,156 S \* 1/2016 Koponen ..... D15/30  
 D813,728 S \* 3/2018 Ito ..... D12/93  
 D817,229 S \* 5/2018 Anderson ..... D12/96  
 D842,349 S \* 3/2019 Kim ..... D15/30  
 D861,537 S \* 10/2019 Lamanna ..... D12/84  
 D871,267 S \* 12/2019 Armigliato ..... D12/93  
 D899,972 S \* 10/2020 Lamanna ..... D12/195  
 D912,578 S \* 3/2021 Egger ..... D12/96  
 D933,532 S \* 10/2021 Kupitza ..... D12/93  
 D944,124 S \* 2/2022 Spada ..... B62D 25/06  
 D955,295 S \* 6/2022 Schwartz ..... D12/96

2013/0202395 A1 8/2013 Levi  
 2020/0259143 A1 \* 8/2020 Sloan ..... B60L 50/66  
 2021/0268865 A1 \* 9/2021 Saroka ..... B60H 1/32284  
 2022/0105791 A1 \* 4/2022 Hendriks ..... B60K 1/00

OTHER PUBLICATIONS

“That’s No Van. That’s a Man.” Man Truck & Bus., Jun. 2, 2021 [online], [retrieved on Oct. 9, 2022]. Retrieved from the Internet <URL: [https://www.man.eu/ntg\\_media/media/en/content\\_medien/doc/bw\\_master/van\\_1/man\\_tge\\_product\\_catalogue.pdf](https://www.man.eu/ntg_media/media/en/content_medien/doc/bw_master/van_1/man_tge_product_catalogue.pdf)>.\*  
 “2008 Man TGM.” Top Speed., Mar. 12, 2012 [online], [retrieved on Oct. 9, 2022]. Retrieved from the Internet <URL: <https://www.topspeed.com/trucks/truck-reviews/man/2008-man-tgm/>>.\*  
 Hall-Geisler, “Nikola Motor Company unveils its electric (mostly) truck.” Tech Crunch., May 19, 2016 [online], [retrieved on Sep. 1, 2021]. Retrieved from the Internet <URL: <https://techcrunch.com/2016/05/19/nikola-motor-company-unveils-its-electric-mostly-truck/>>.  
 Saleem, “Hyzon Motors Is Ready To Exploit Its First-Mover Advantage . . .” WCCF Tech., May 18, 2021 [online], [retrieved on Sep. 1, 2021]. Retrieved from the Internet <URL: <https://wccftech.com/hyzon-motors-is-ready-to-exploit-its-first-mover-advantage-by-launching-hydrogen-fuel-cell-powered-co>>.  
 “Top 10 Chinese Heavy-duty Truck Manufacturers.” Car Logos., Jul. 1, 2021 [online], [retrieved on Sep. 1, 2021]. Retrieved from the Internet <URL: <https://www.carlogos.org/reviews/chinese-heavy-duty-truck-manufacturers.html>>.

\* cited by examiner



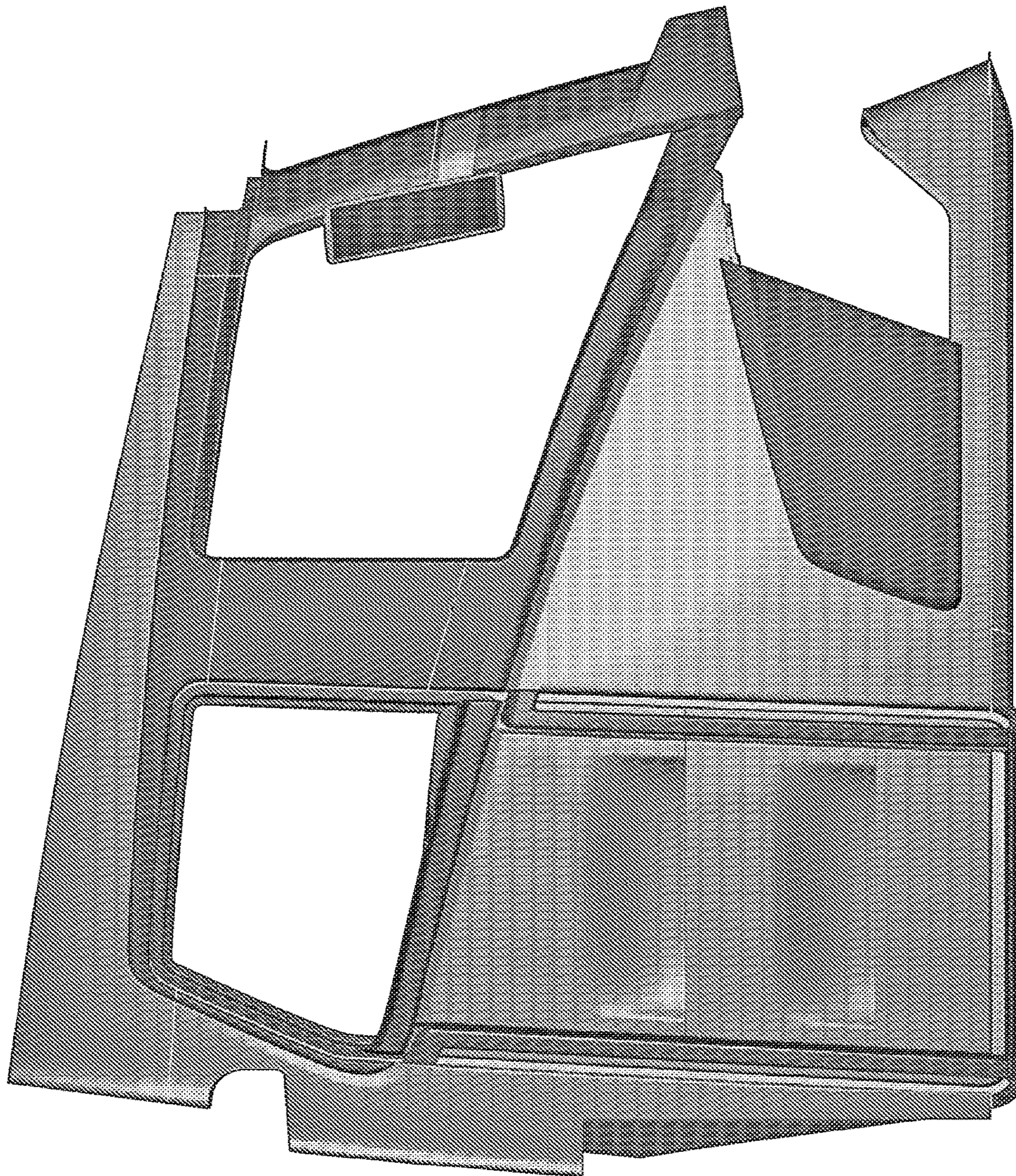

FIG. 1



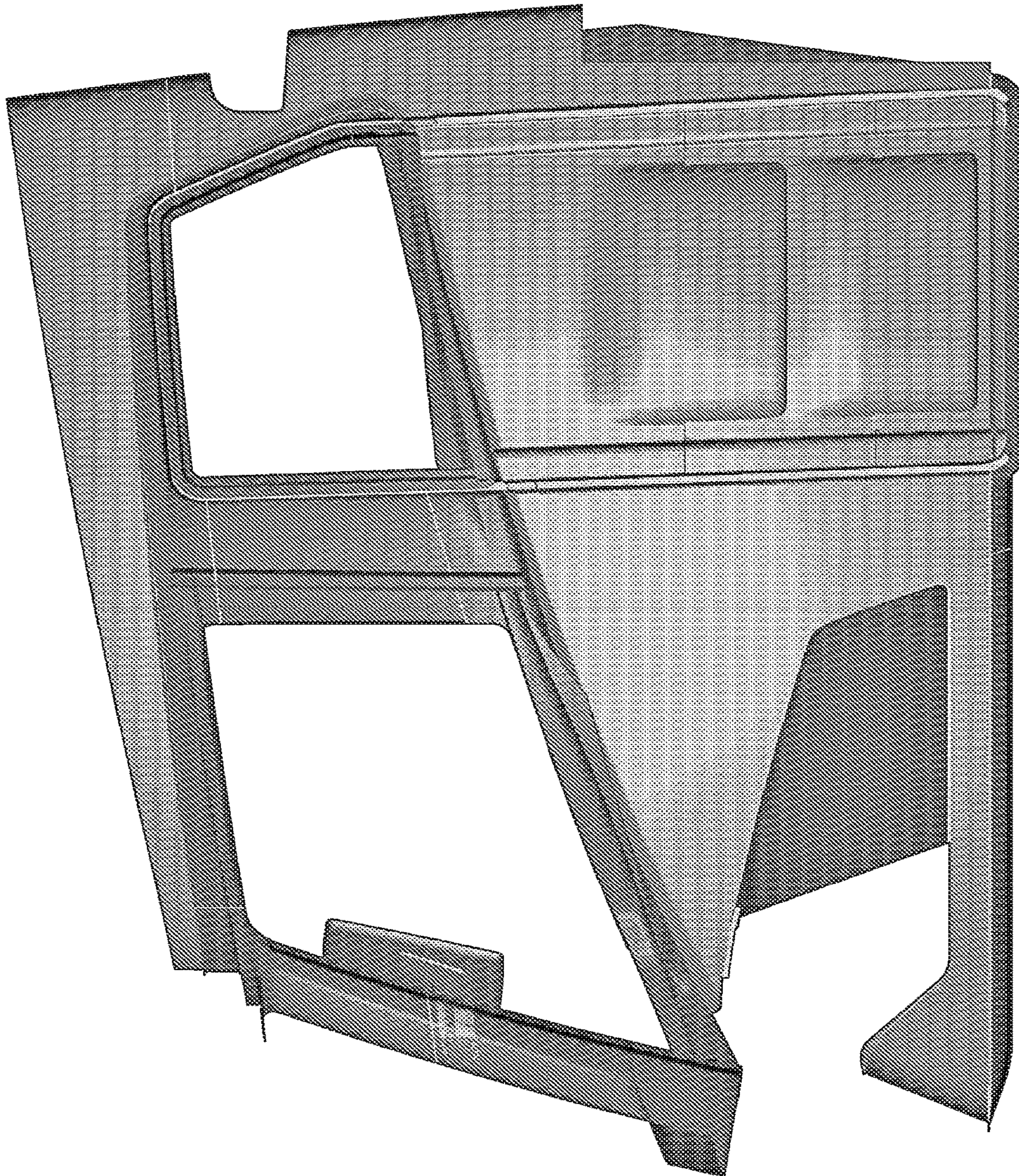

FIG. 2



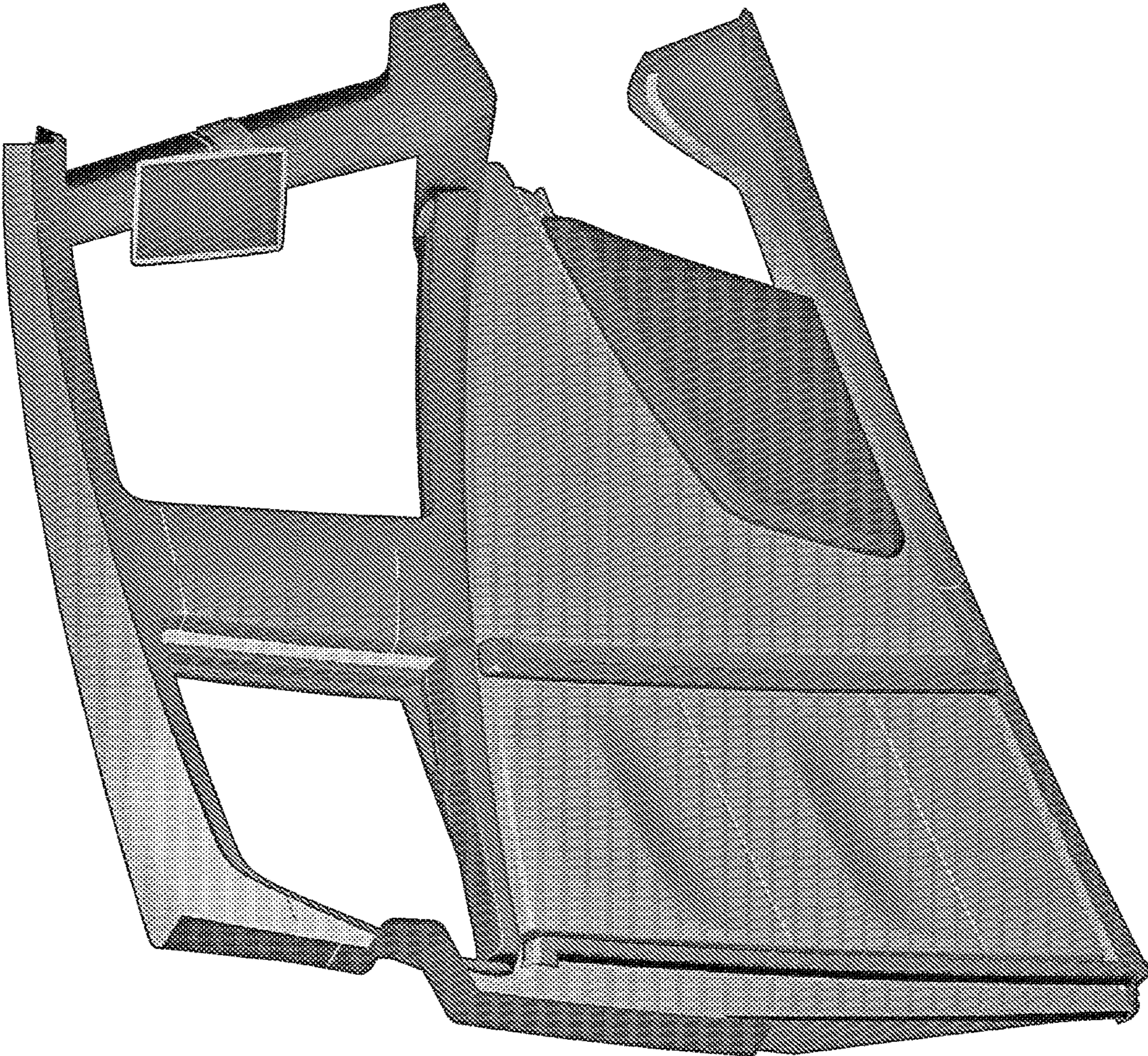

FIG. 3



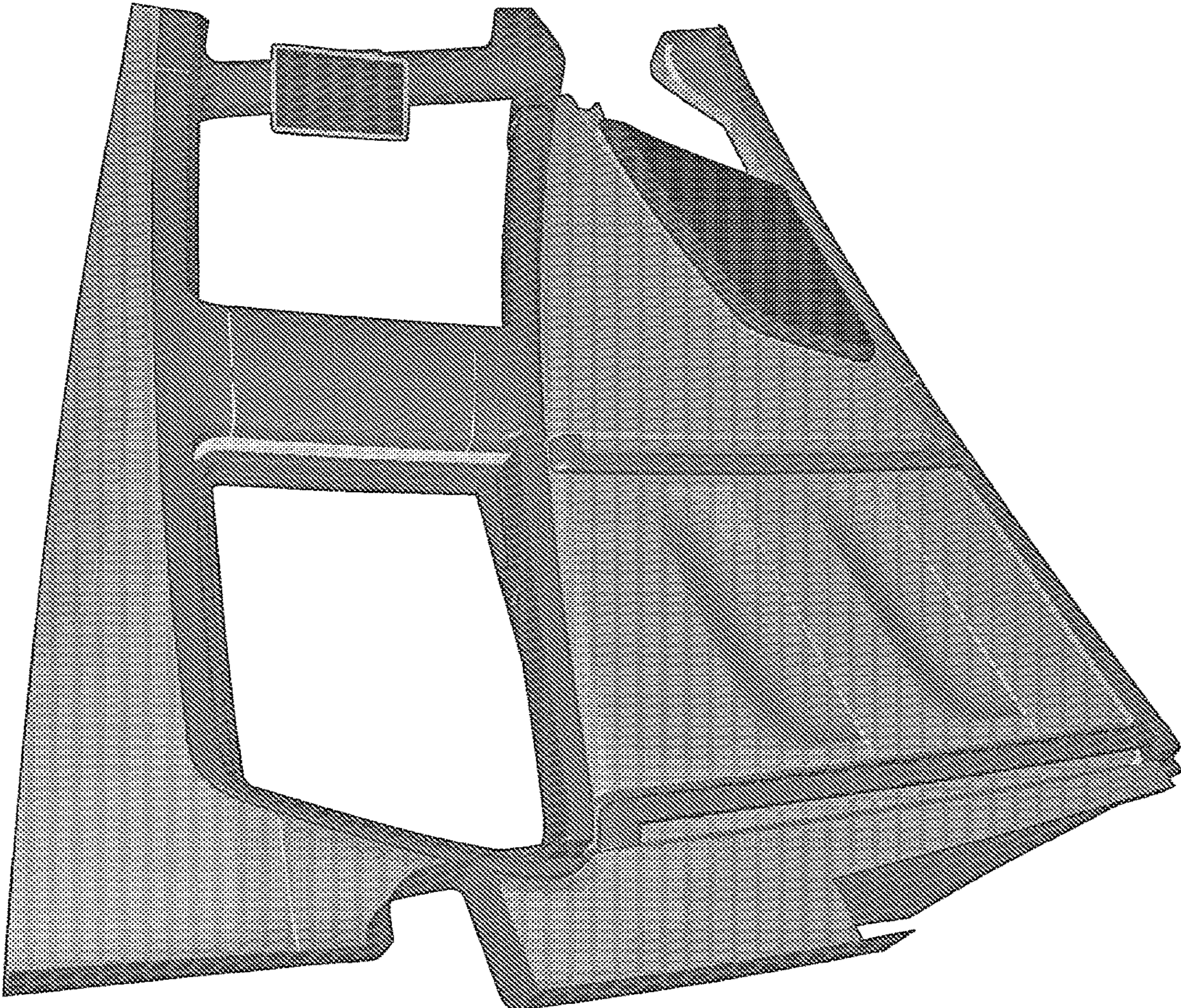

FIG. 4



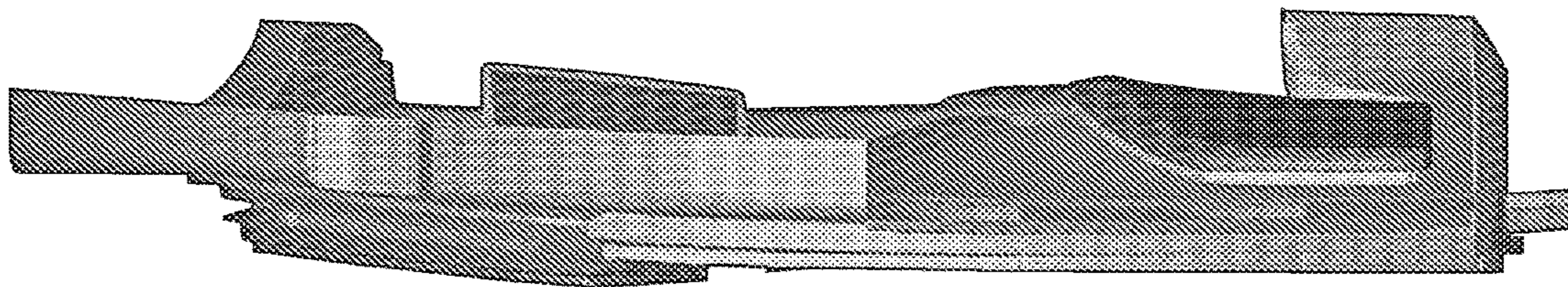

FIG. 5

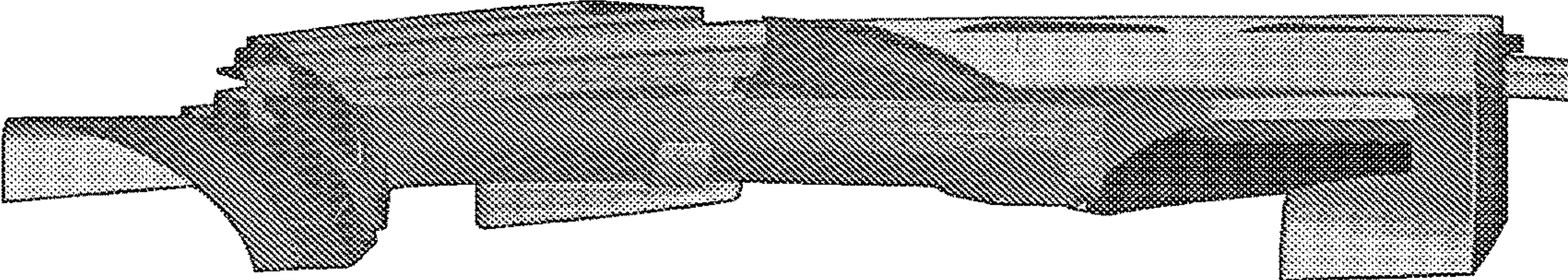

FIG. 6



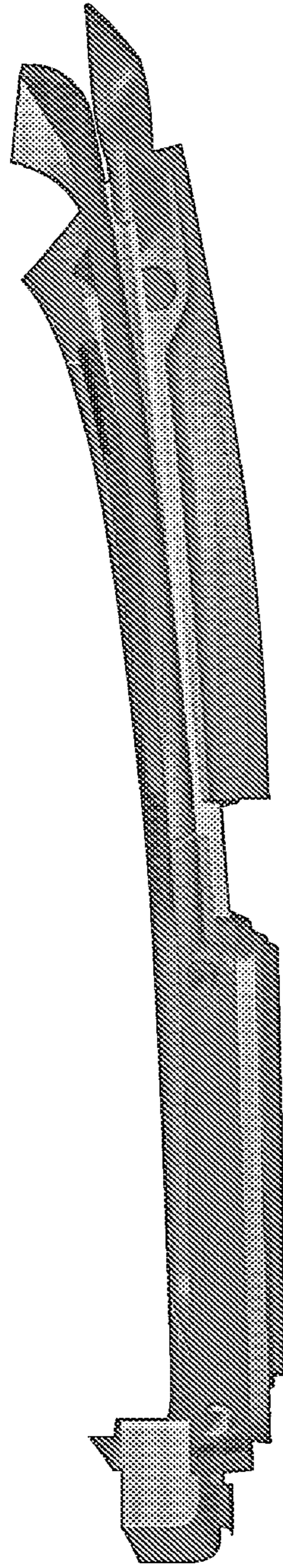

FIG. 7



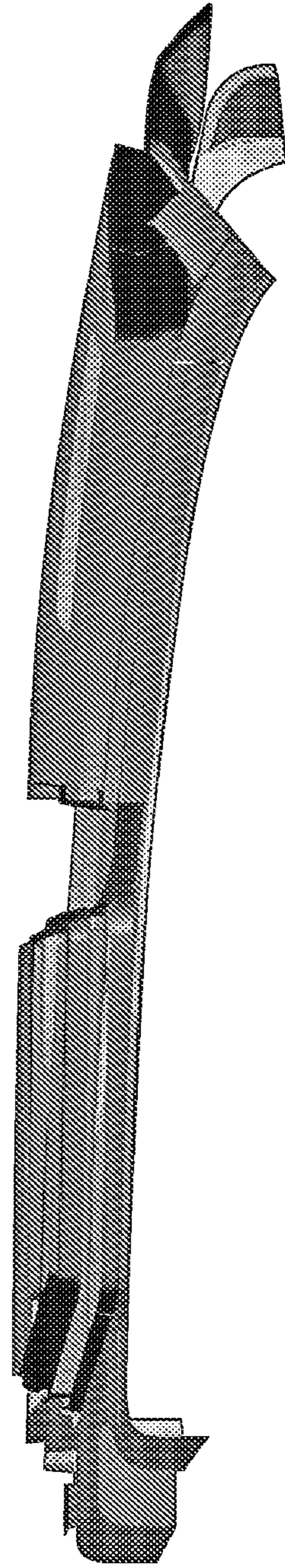

FIG. 8



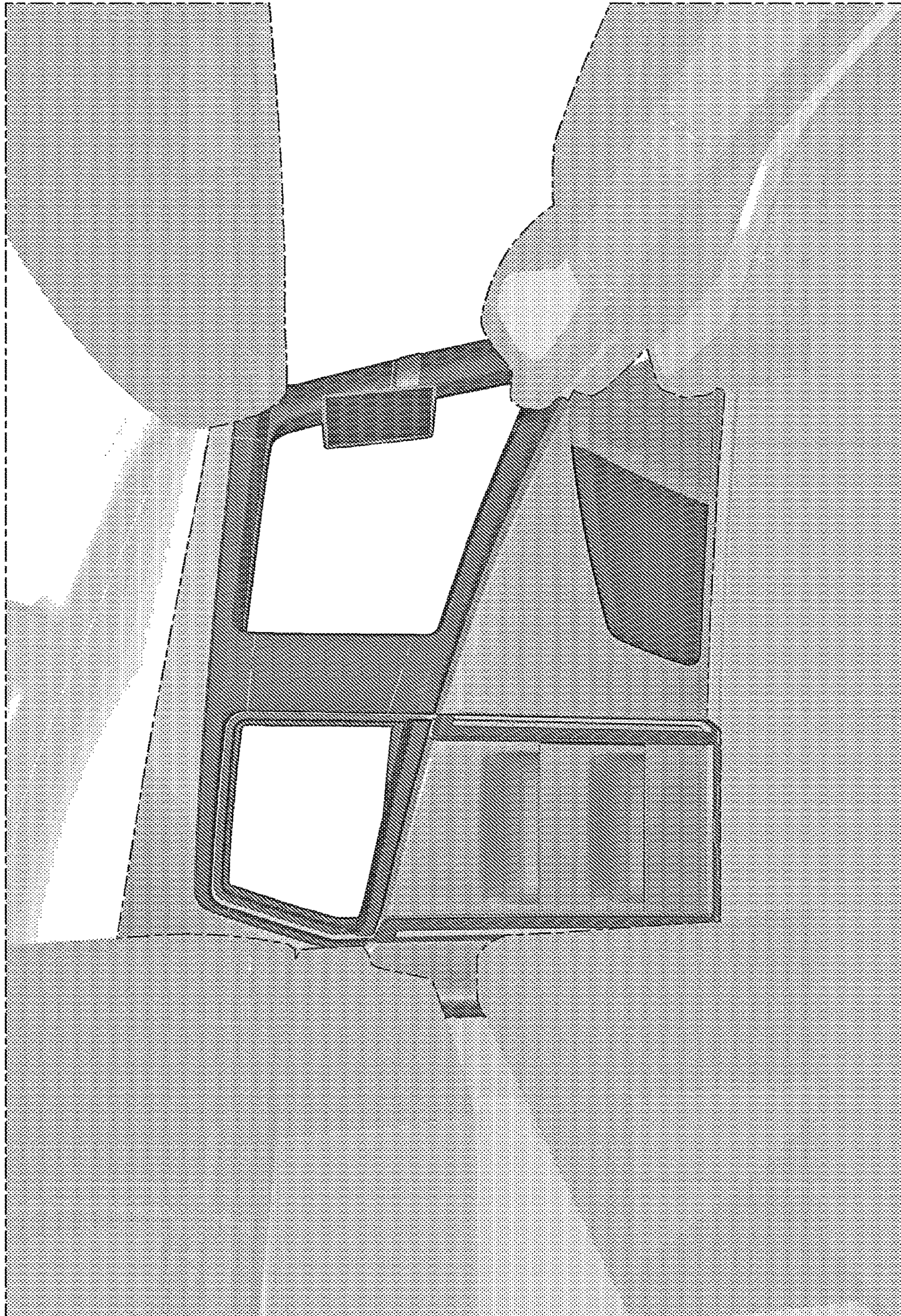

FIG. 9