



US00D978662S

(12) **United States Design Patent** (10) **Patent No.:** **US D978,662 S**  
**Plasencia et al.** (45) **Date of Patent:** **\*\* Feb. 21, 2023**

(54) **SENSOR PACKAGE**

(74) *Attorney, Agent, or Firm* — Barclay Damon LLP

(71) Applicant: **Inficon, Inc.**, East Syracuse, NY (US)

(57) **CLAIM**

The ornamental design for a sensor package, as shown and described.

(72) Inventors: **Joel Plasencia**, Liverpool, NY (US);  
**Russell Foster**, Kansas City, MO (US);  
**Dale Sass**, Grandview, MO (US); **John R. Hardesty, Jr.**, Climax Springs, MO (US); **Jennifer Reakes**, Hastings, NY (US)

**DESCRIPTION**

(73) Assignee: **INFICON, Inc.**, East Syracuse, NY (US)

FIG. 1 is a top perspective view of the sensor package shown with the cover and base applied according to our new design; FIG. 2 is a top perspective view of the cover of the sensor package shown removed for clarity of disclosure; FIG. 3 is a top perspective view of the base of the sensor package shown removed for clarity of disclosure; FIG. 4 is a top plan view of the sensor package of FIG. 1; FIG. 5 is a left side view thereof; FIG. 6 is a right side view thereof; FIG. 7 is a front facing view thereof; FIG. 8 is a rear facing view thereof; FIG. 9 is a top perspective view of the base of the sensor package shown in FIG. 3 in an environment of use; FIG. 10 is a bottom perspective view thereof; FIG. 11 is a top plan view of the base of the sensor package shown in FIG. 3; FIG. 12 is a left side view thereof; FIG. 13 is a right side view thereof; FIG. 14 is a front facing view thereof; FIG. 15 is a rear facing view thereof; FIG. 16 is a top plan view of the cover of the sensor package shown in FIG. 2; FIG. 17 is a left side view thereof; FIG. 18 is a right side view thereof; FIG. 19 is a front facing view thereof; FIG. 20 is a rear facing view thereof; FIG. 21 is a bottom plan view thereof; FIG. 22 is a bottom perspective view thereof; and, FIG. 23 is a bottom plan view of the sensor package shown in FIG. 1.

(\*\*) Term: **15 Years**

(21) Appl. No.: **29/747,599**

(22) Filed: **Aug. 24, 2020**

(51) **LOC (14) Cl.** ..... **09-03**

(52) **U.S. Cl.**  
USPC ..... **D9/418; D9/425**

(58) **Field of Classification Search**  
USPC .... D7/392.1, 396.2; D9/434, 435, 436, 440, D9/443, 447, 449, 414, 418-420,  
(Continued)

Broken lines as shown are intended to show the environment of the design and do not form a part of the claimed design.

(56) **References Cited**

**U.S. PATENT DOCUMENTS**

D136,657 S \* 11/1943 Funke ..... D8/358  
D187,052 S \* 1/1960 Kellogg ..... D9/419  
(Continued)

**OTHER PUBLICATIONS**

Youtube. Inficon EDC—A Closer Look at Crystal Manufacturing. Feb. 1, 2021. <https://www.youtube.com/watch?v=tVoq4zGba4k> (Year: 2021).\*

(Continued)

*Primary Examiner* — Darcey E Gottschalk

**1 Claim, 7 Drawing Sheets**

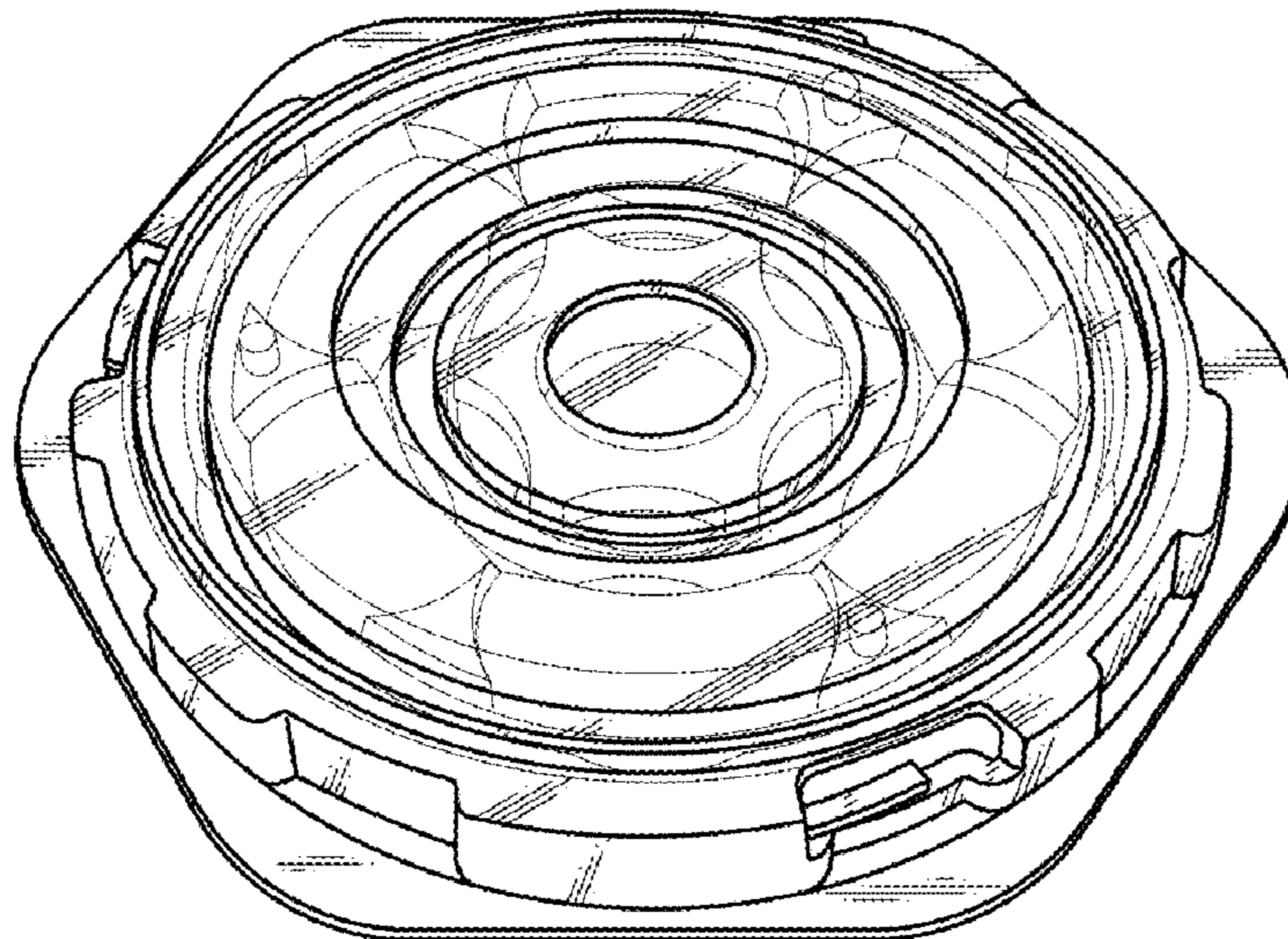

(58) **Field of Classification Search**  
 USPC ..... D9/452-454, 455, 456, 499, 424, 425,  
                   D9/428, 430, 737, 748, 756  
 CPC . B65D 5/50; B65D 81/34; A45D 29/00; A61J  
                   1/1425; B65H 75/44  
 See application file for complete search history.

(56) **References Cited**

U.S. PATENT DOCUMENTS

D200,819 S *	4/1965	Perun .....	D9/434
D224,208 S *	7/1972	Kuchar .....	D9/418
3,752,303 A *	8/1973	Foster .....	B65D 75/366 206/408
D291,843 S *	9/1987	Searle .....	D3/904
D324,997 S *	3/1992	Jones .....	D28/91.1
5,392,949 A *	2/1995	McKenna .....	B65D 47/0847 220/276
D381,162 S *	7/1997	Berend .....	D9/454
D398,846 S *	9/1998	Wyslotsky .....	D9/425
D398,847 S *	9/1998	Wyslotsky .....	D9/425
D418,750 S *	1/2000	Blin .....	D9/430
D427,902 S *	7/2000	Hayes .....	D9/425
D515,924 S *	2/2006	Grant .....	D9/418

D533,773 S *	12/2006	Sander .....	D9/418
D562,134 S *	2/2008	Studee .....	D9/454
D568,766 S *	5/2008	Nottingham .....	D9/414
D578,877 S *	10/2008	Lovett .....	D9/425
D578,882 S *	10/2008	Friedland .....	D9/425
D620,790 S *	8/2010	Lovett .....	D9/425
D681,459 S *	5/2013	Ramsey .....	D9/454
D720,629 S *	1/2015	Snedden .....	D9/425
D795,072 S *	8/2017	Haddad .....	D9/454
D808,790 S *	1/2018	Ricci .....	D9/418
D896,067 S *	9/2020	Giwani .....	D9/418
D901,307 S *	11/2020	Ha .....	D9/425
D939,359 S *	12/2021	Washington .....	D9/425
D959,976 S *	8/2022	Resuello, Jr. ....	D9/418
D962,050 S *	8/2022	Cook .....	D9/425
D966,088 S *	10/2022	Cook .....	D9/425
D966,089 S *	10/2022	Cook .....	D9/425

OTHER PUBLICATIONS

Phillip Technologies. Product Catalog. 2020. [https://www.philliptech.com/wp-content/uploads/2019/07/Phillip-Tech-Product-Catalog\\_WEB-2019.pdf](https://www.philliptech.com/wp-content/uploads/2019/07/Phillip-Tech-Product-Catalog_WEB-2019.pdf) (Year: 2020).\*

\* cited by examiner

FIG.1

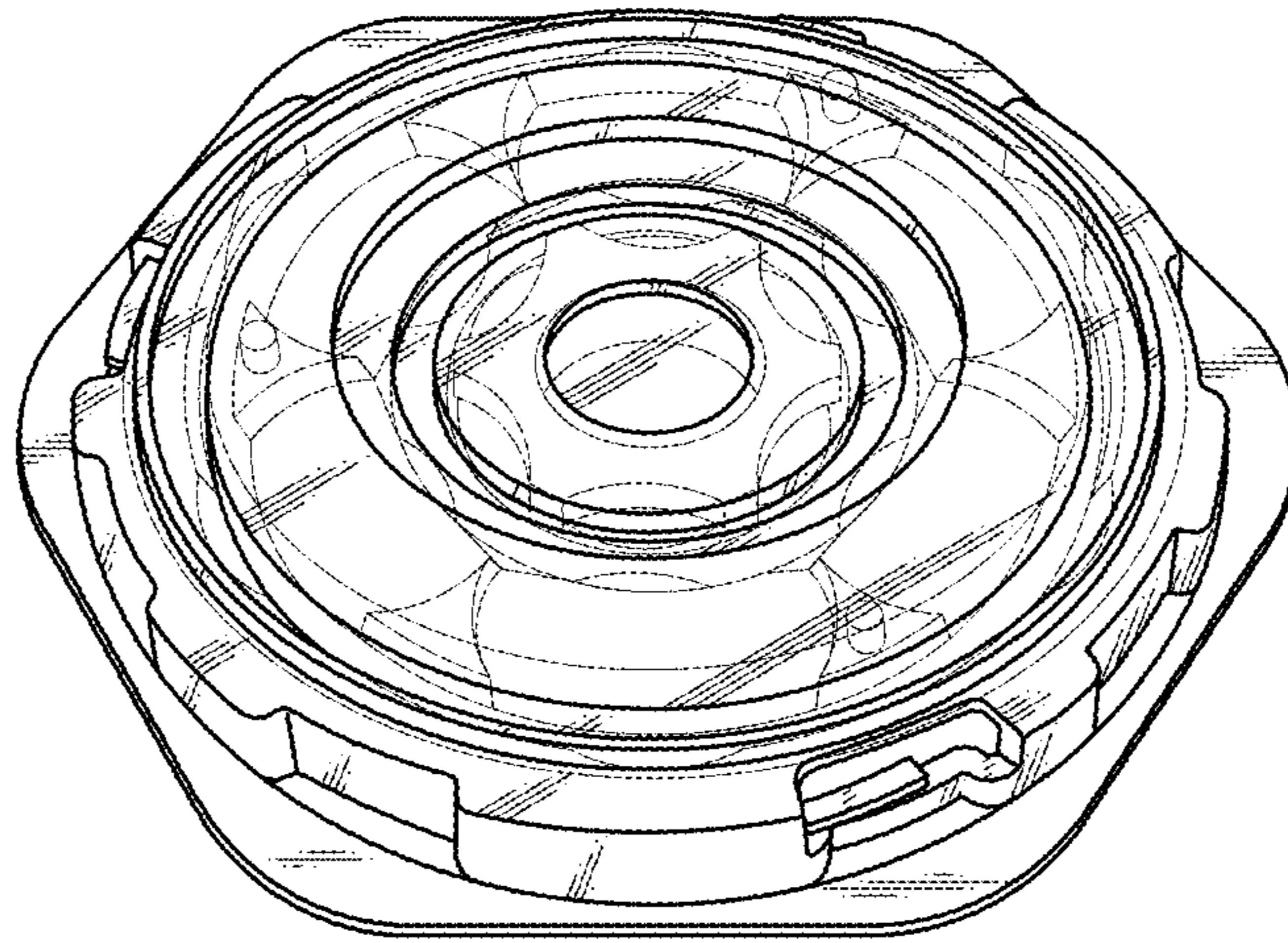

FIG.2

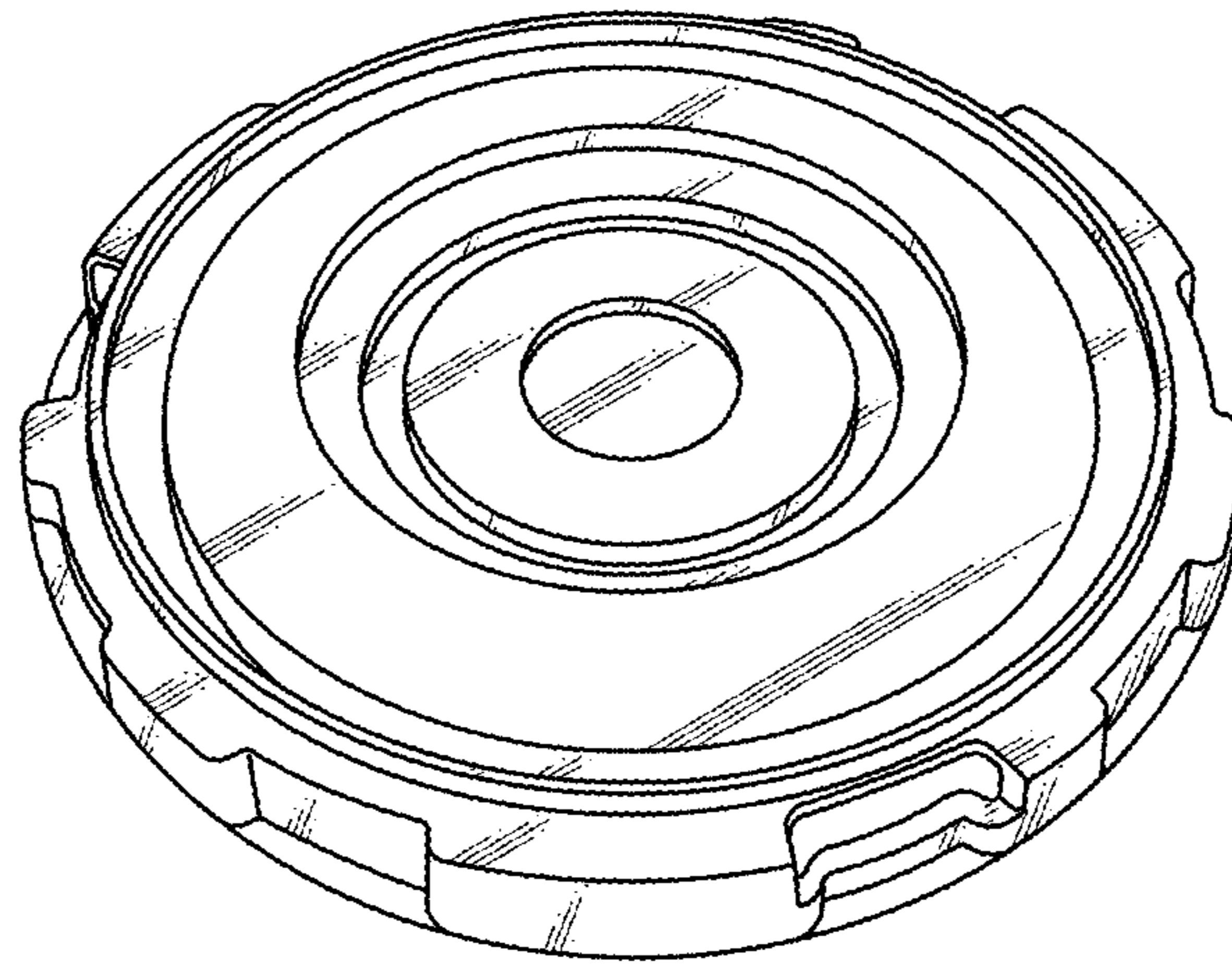
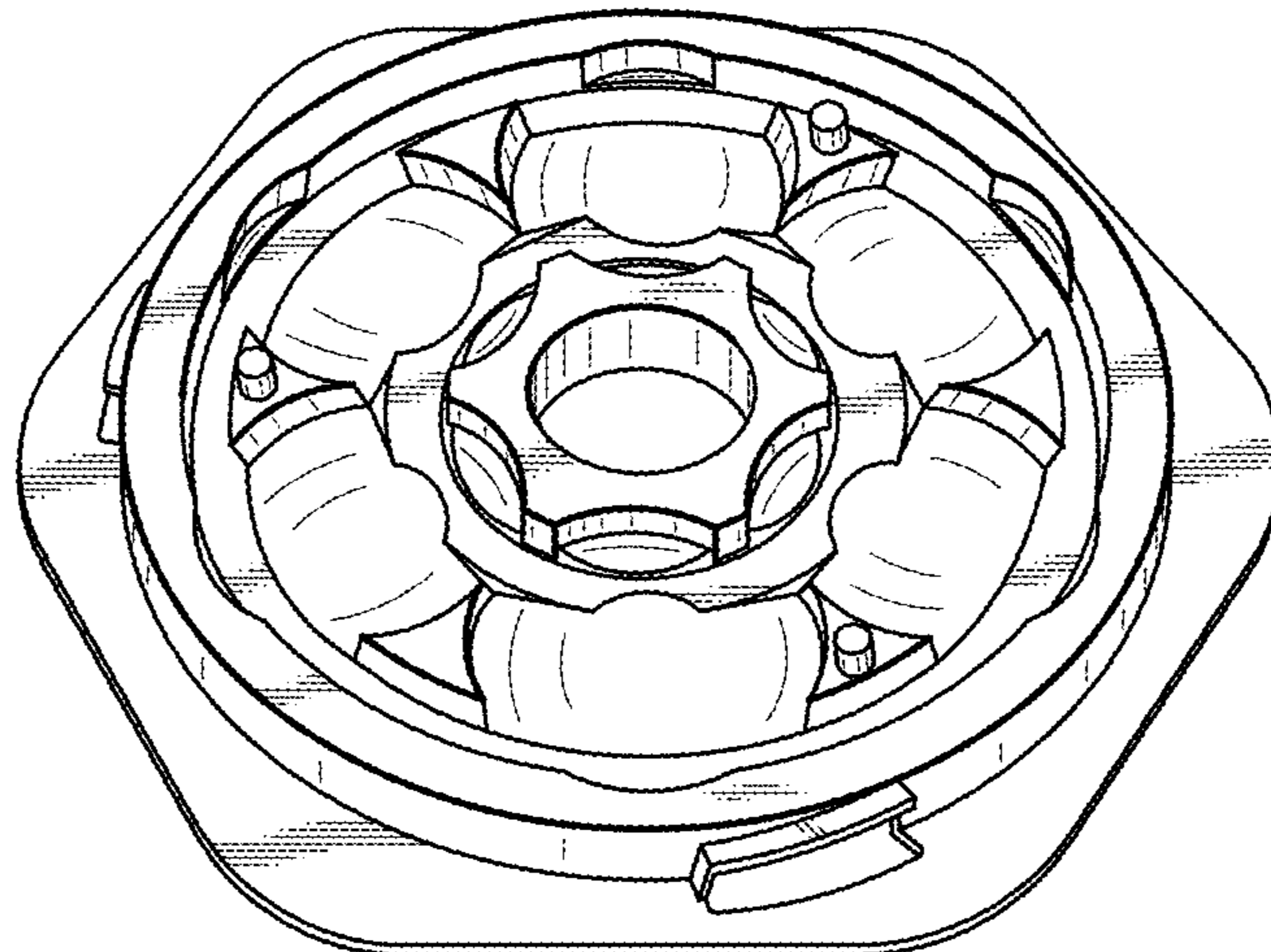

FIG.3



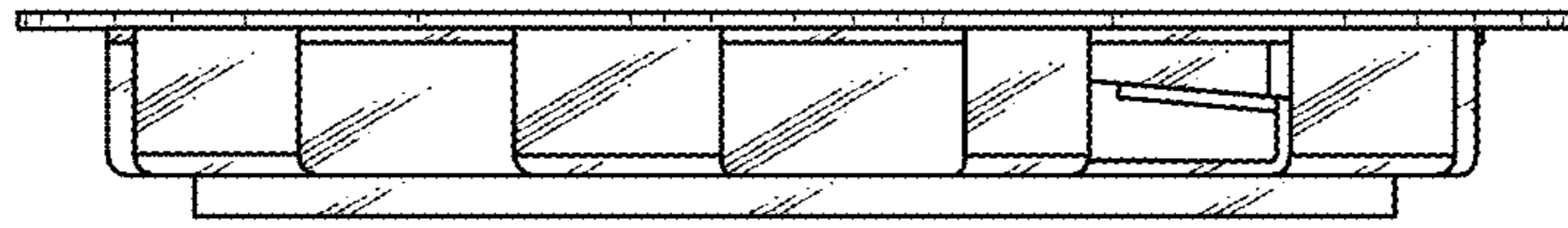

FIG. 7

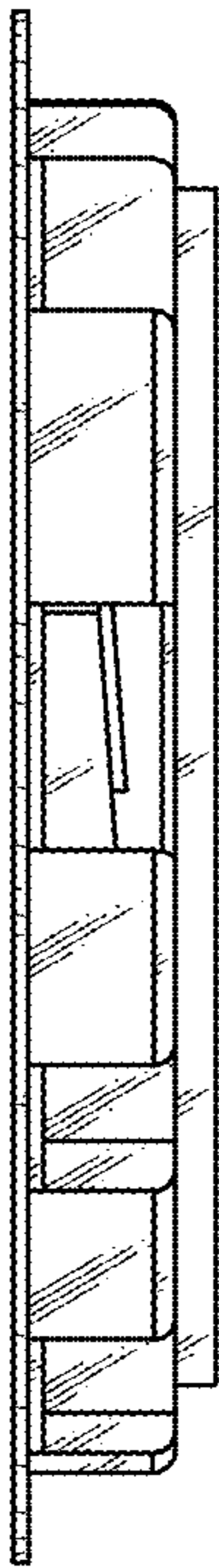

FIG. 5

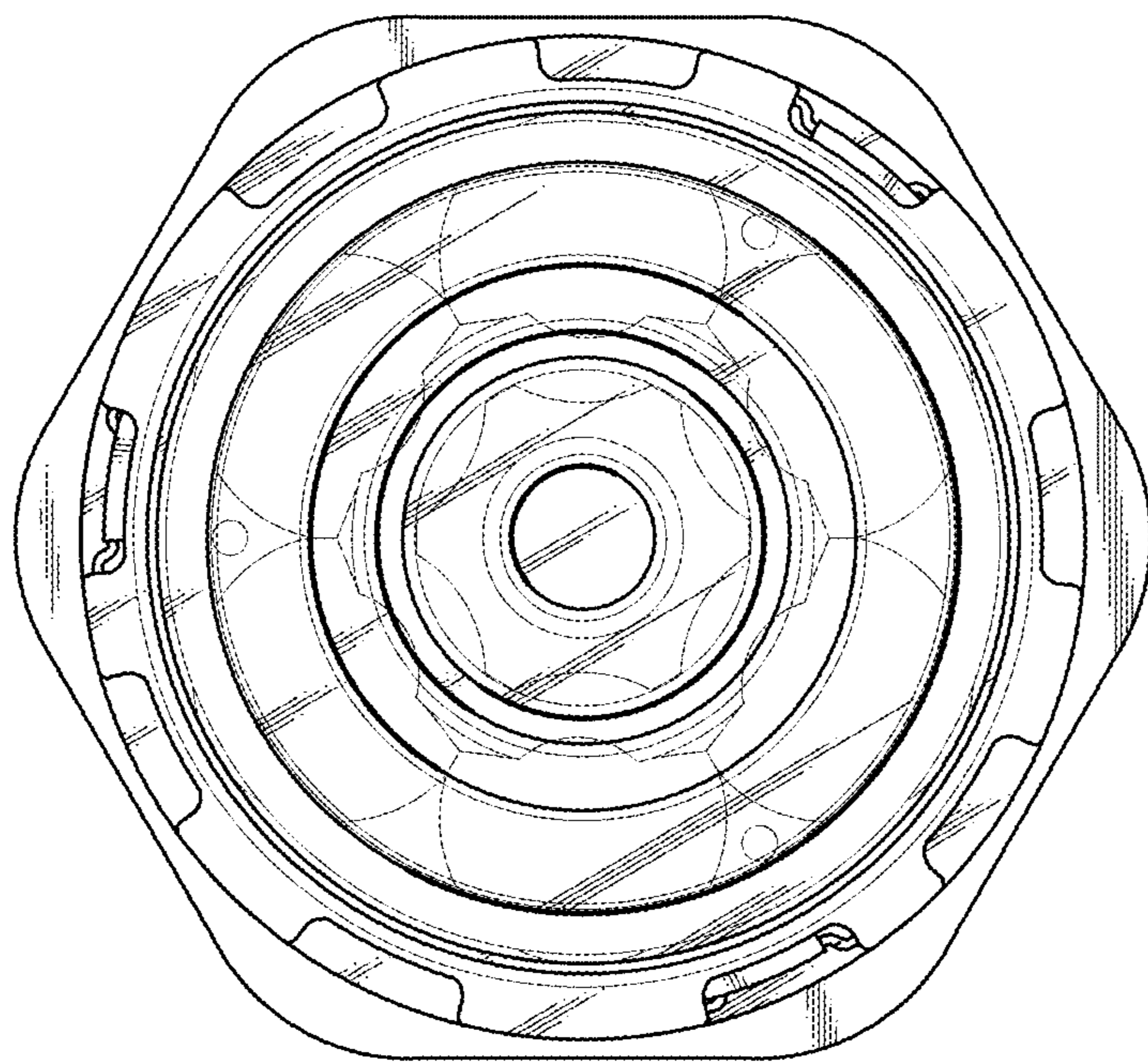

FIG. 4

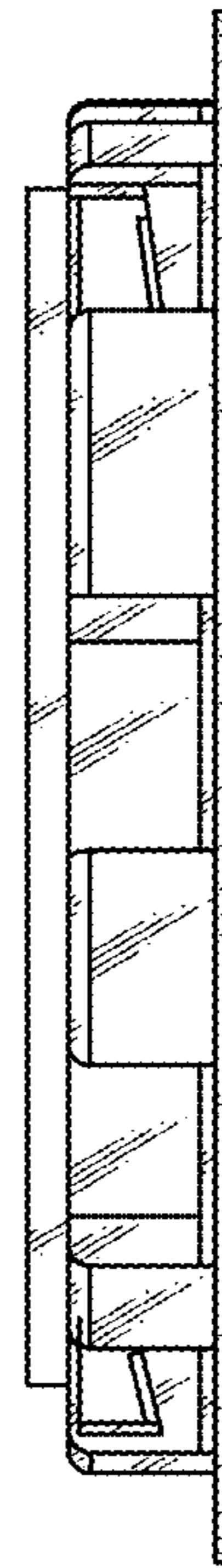

FIG. 6



FIG. 8

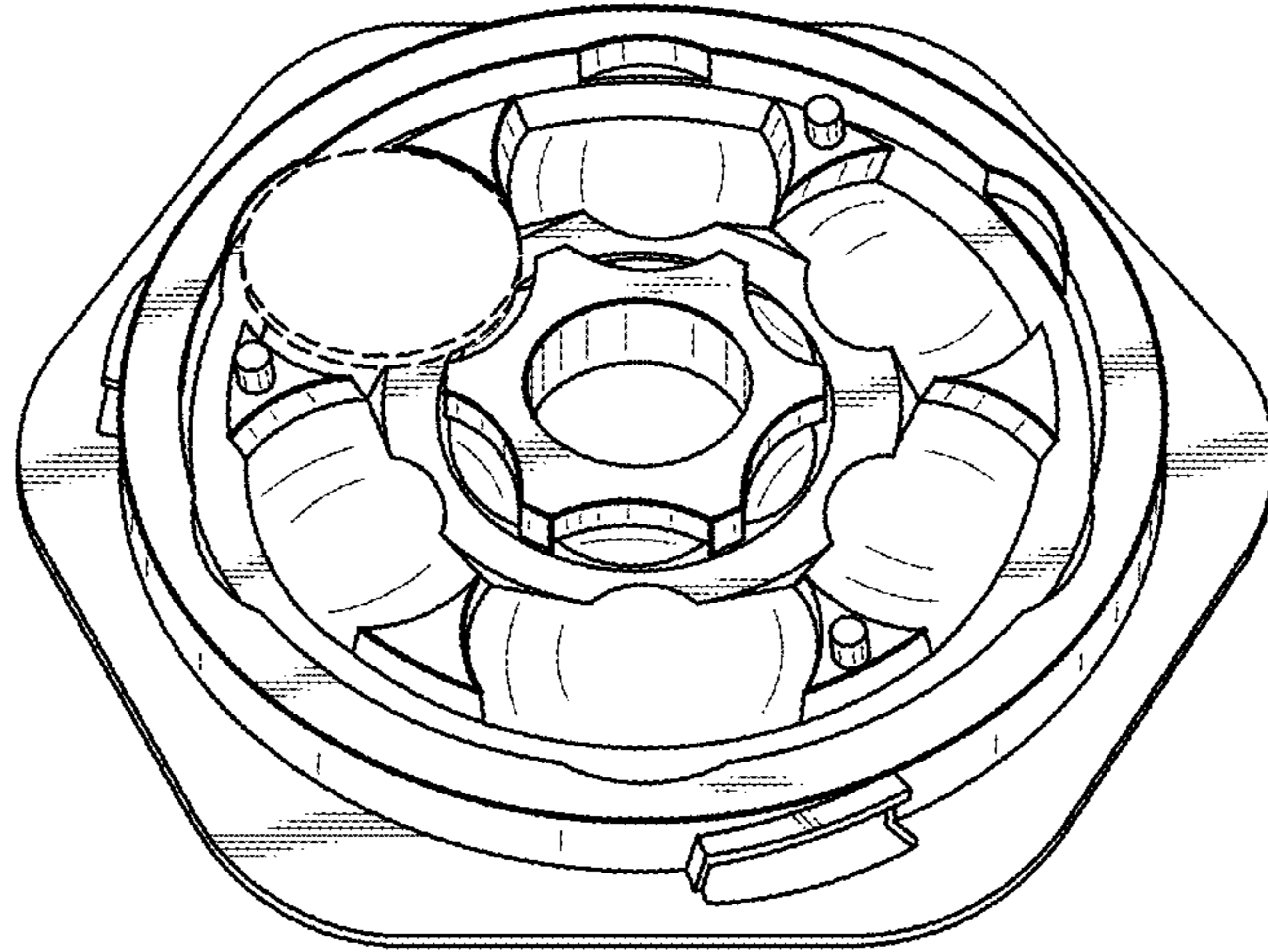

FIG. 9

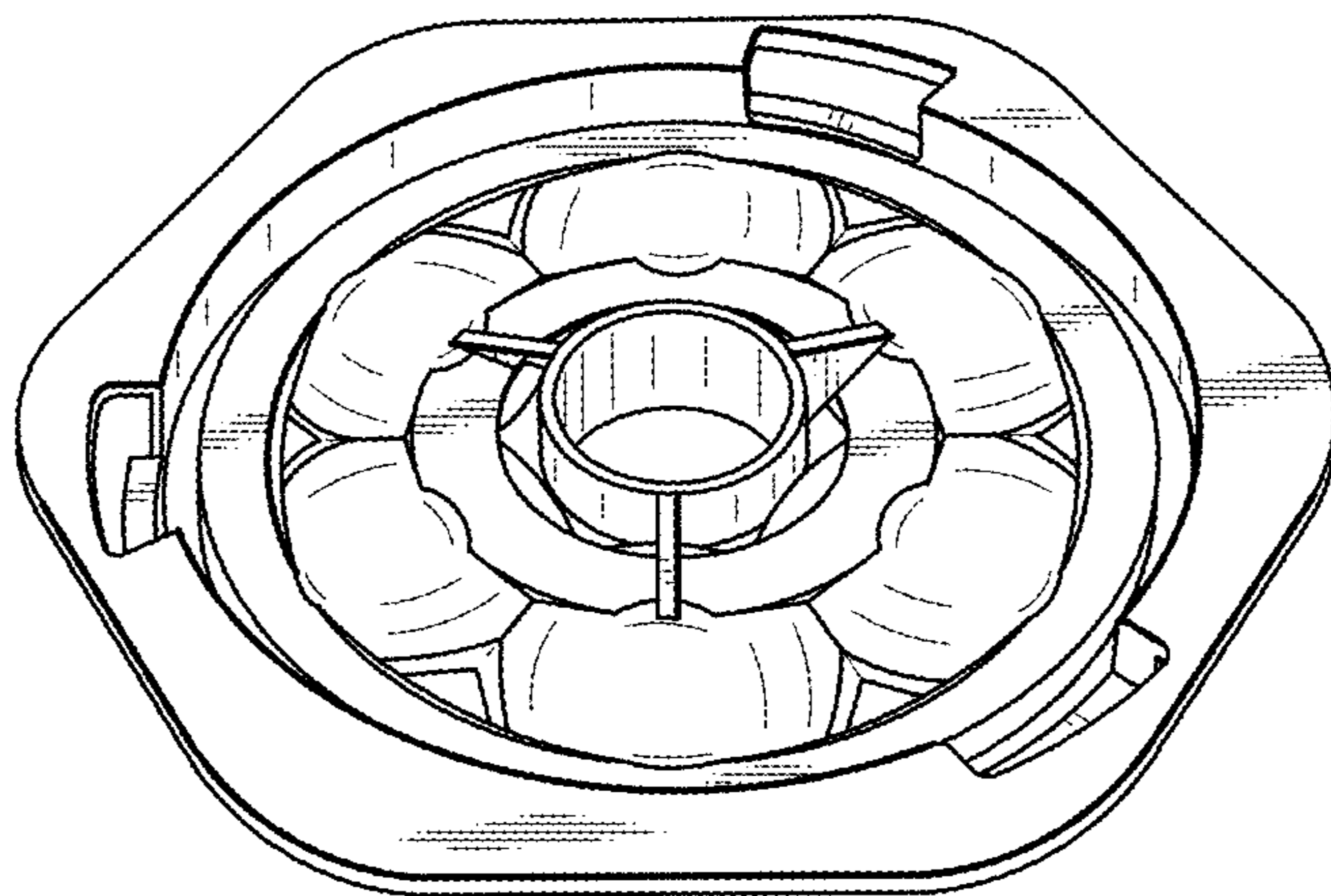

FIG. 10

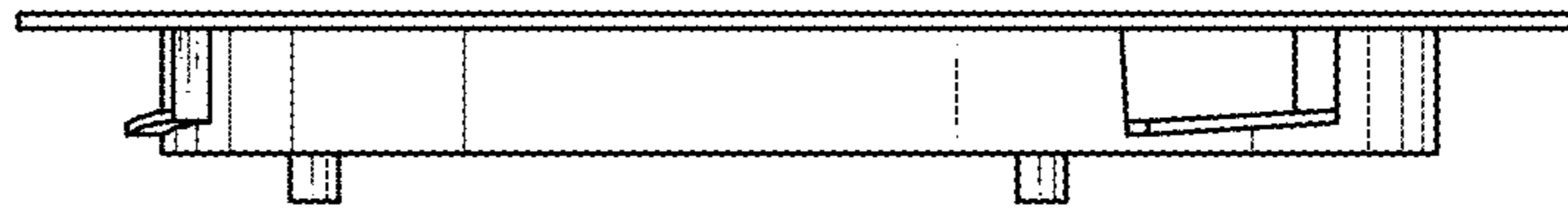

FIG. 14

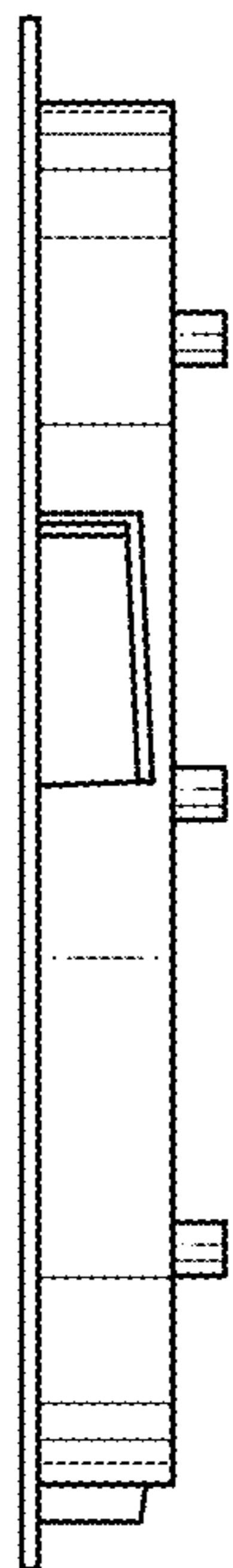

FIG. 12

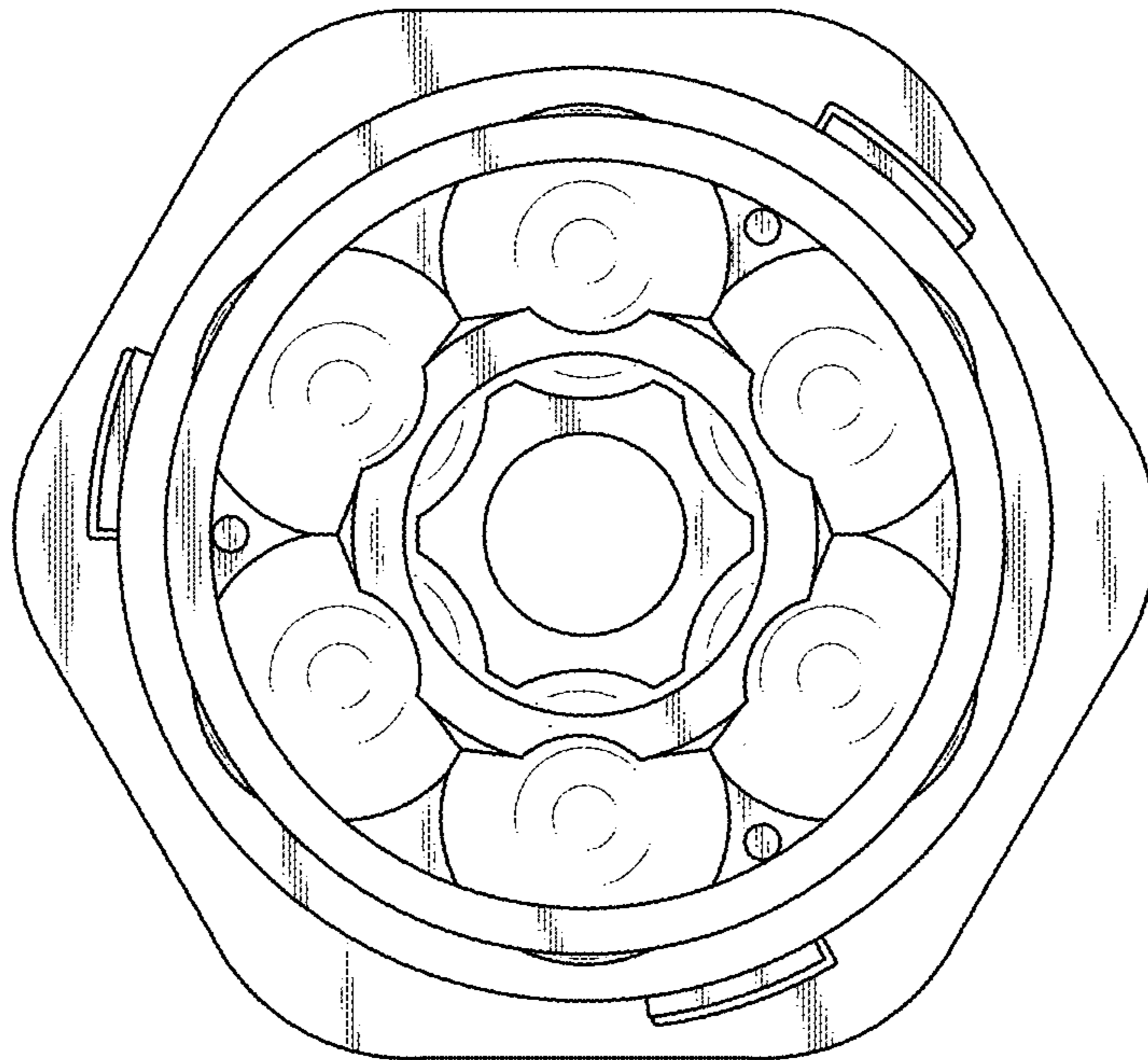

FIG. 11

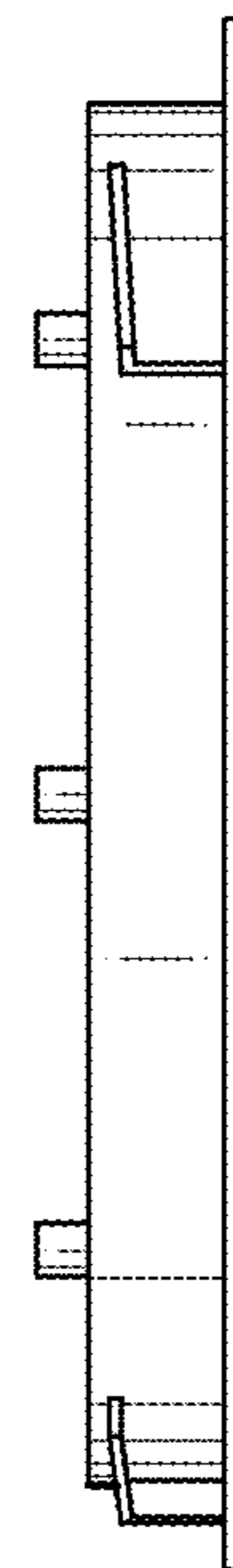

FIG. 13



FIG. 15

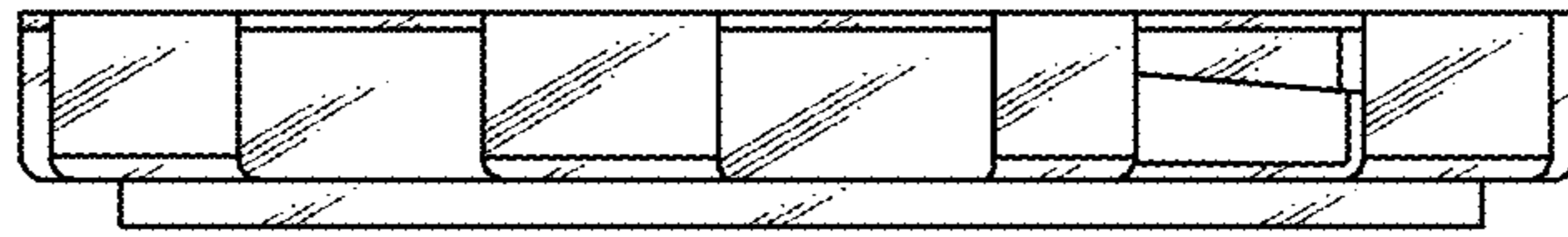

FIG. 19

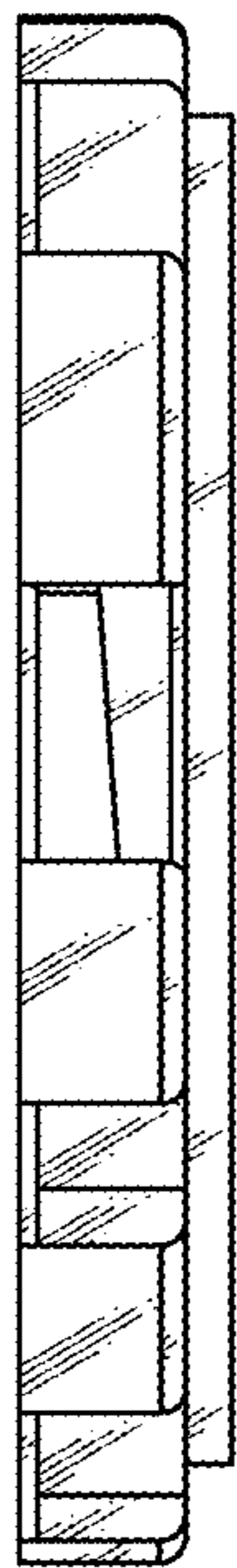

FIG. 17

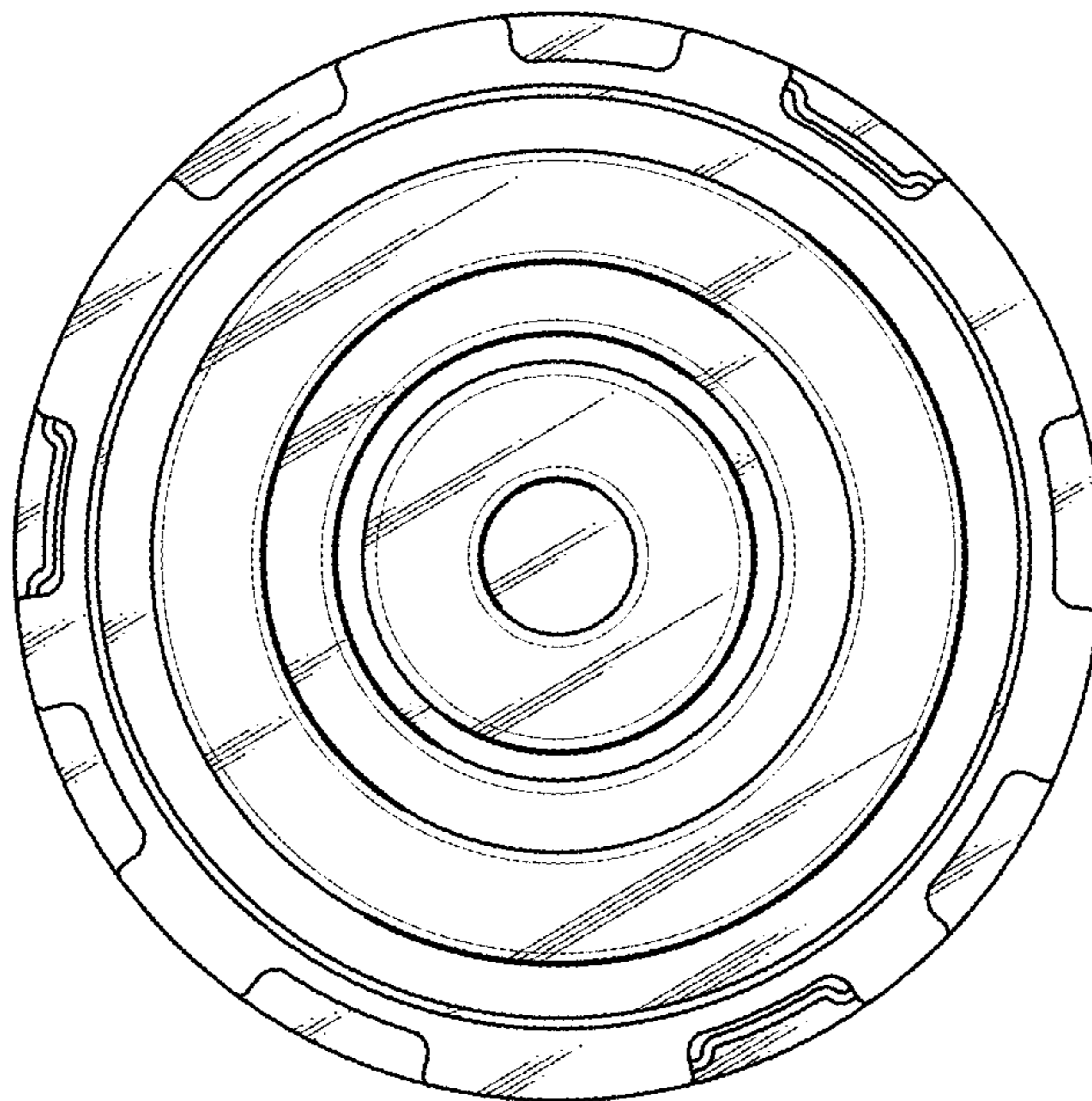

FIG. 16

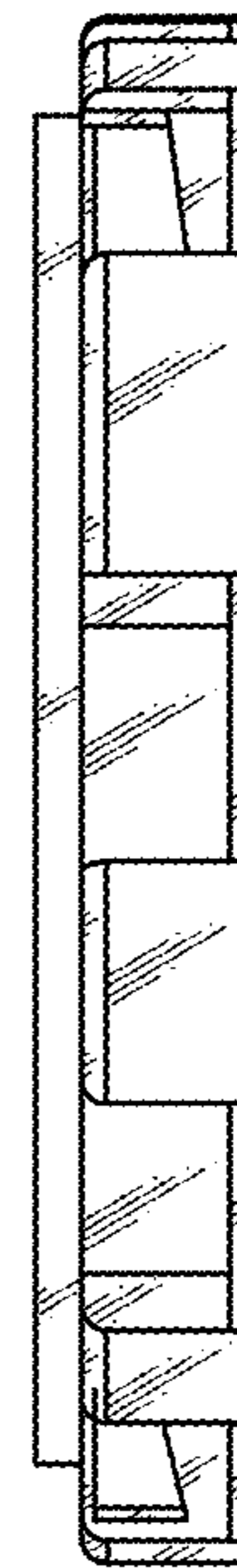

FIG. 18

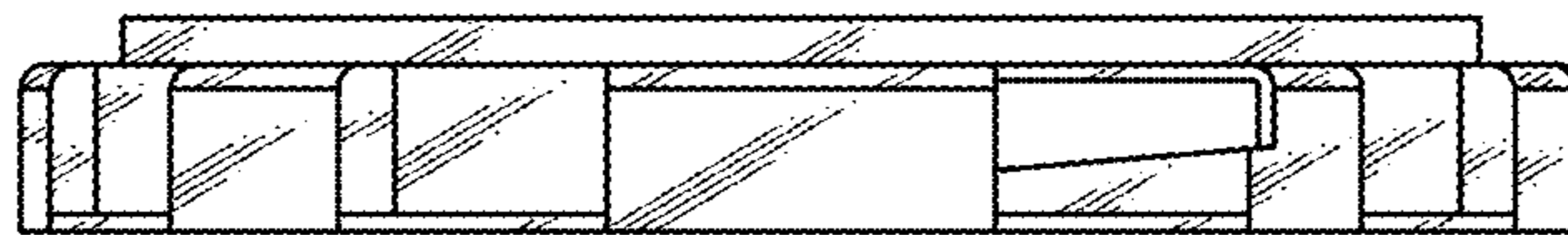

FIG. 20

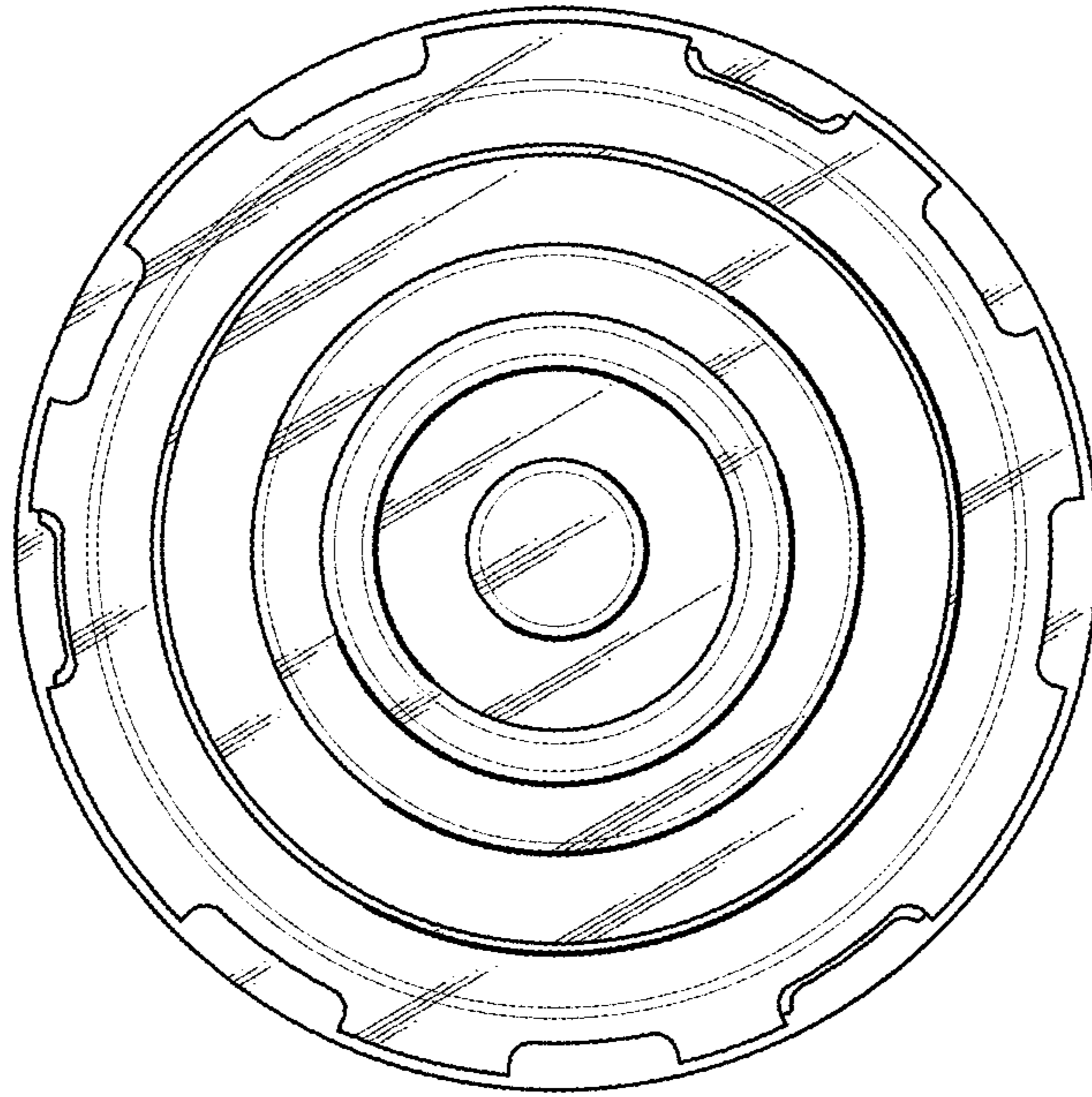

FIG. 21

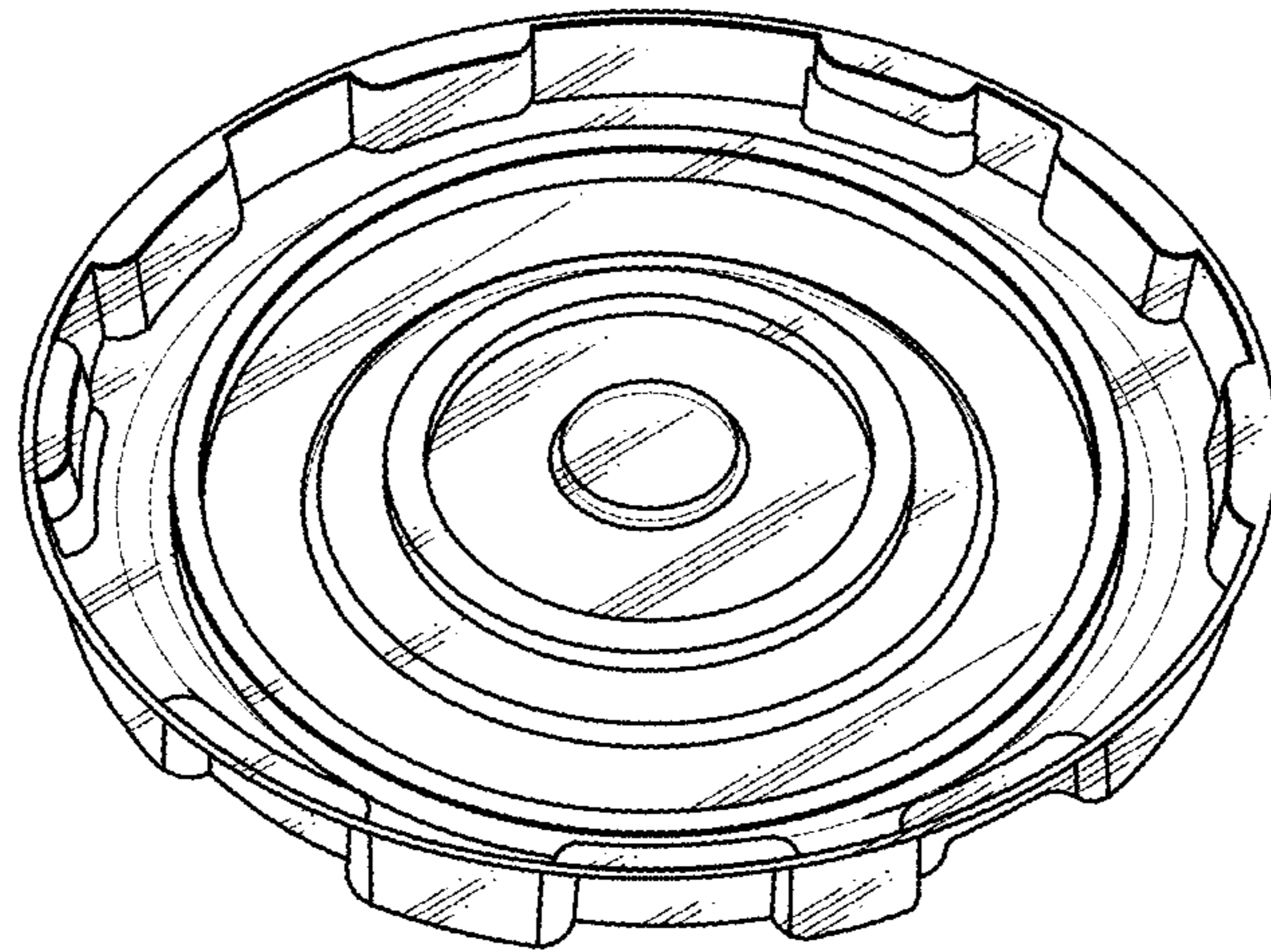

FIG. 22



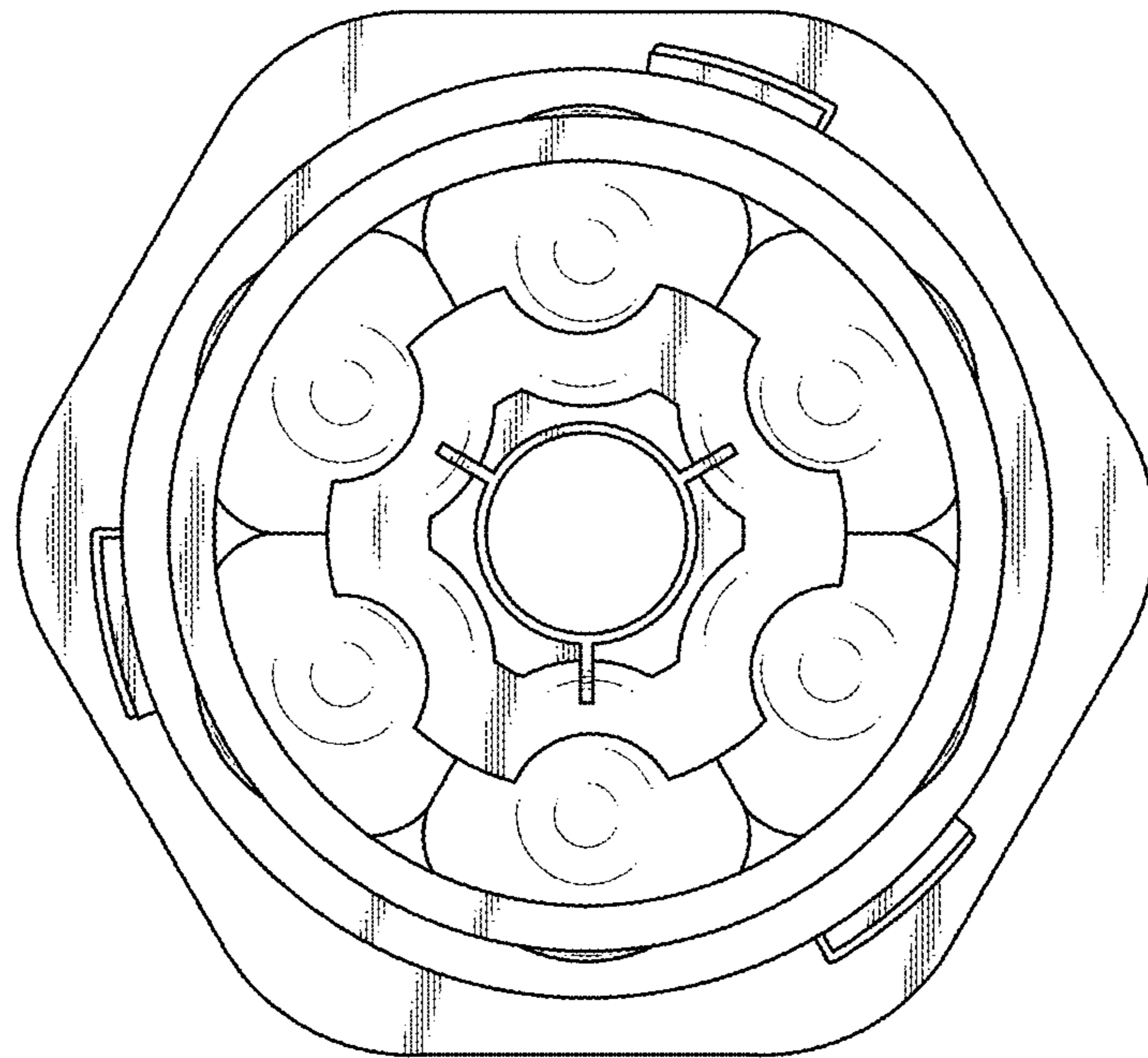

FIG.23