



US00D978600S

(12) **United States Design Patent**
Bhogal et al.

(10) **Patent No.:** **US D978,600 S**

(45) **Date of Patent:** **** Feb. 21, 2023**

- (54) **COOKING VESSEL**
- (71) Applicant: **June Life, Inc.**, San Francisco, CA (US)
- (72) Inventors: **Nikhil Bhogal**, San Francisco, CA (US); **Mathias Watson Schmidt**, San Francisco, CA (US); **Nicholas Beyrer**, San Francisco, CA (US)
- (73) Assignee: **June Life, Inc.**, San Francisco, CA (US)
- (**) Term: **15 Years**
- (21) Appl. No.: **29/794,405**
- (22) Filed: **Jun. 11, 2021**
- (51) **LOC (14) Cl.** **07-02**
- (52) **U.S. Cl.**
USPC **D7/354**
- (58) **Field of Classification Search**
USPC D7/323, 354-361
CPC .. A47J 27/00; A47J 27/04; A47J 27/05; A47J 27/08; A47J 27/09; A47J 27/092; A47J 36/025; A47J 36/06; A47J 36/08; A47J 36/10; A47J 36/12; A47J 37/12; A47J 37/1204; A47J 37/1209; H05B 6/02; H05B 6/06; H05B 6/12
See application file for complete search history.

4,876,953 A	10/1989	Imamura et al.
5,170,024 A	12/1992	Hanatani et al.
5,360,965 A	11/1994	Ishii et al.
5,361,681 A	11/1994	Hedstroem et al.
5,412,448 A	5/1995	Kunishige
D360,804 S *	8/1995	Hamada D7/354
5,498,856 A	3/1996	Carlsson
5,546,475 A	8/1996	Bolle et al.
6,299,921 B1	10/2001	Loeffler et al.
6,310,964 B1	10/2001	Mohan et al.
6,359,270 B1	3/2002	Bridson
6,384,384 B1	5/2002	Connolly et al.
6,486,453 B1	11/2002	Bales et al.
6,759,635 B2	7/2004	Lile
6,789,067 B1	9/2004	Liebenow
6,821,016 B2	11/2004	Sato et al.
6,856,247 B1	2/2005	Wallace
6,862,494 B2	3/2005	Hu et al.
7,013,661 B2	3/2006	Gatling et al.
7,102,107 B1	9/2006	Chapman
7,150,891 B2	12/2006	Greiner et al.
7,445,381 B2	11/2008	Rund et al.
7,516,692 B2	4/2009	Pirkle et al.
7,566,168 B2	7/2009	Rund et al.
7,663,502 B2	2/2010	Breed
D620,743 S *	8/2010	Hsiao D7/354
7,845,823 B2	12/2010	Mueller et al.
8,091,543 B2	1/2012	Baumann et al.
8,193,474 B2	6/2012	Harris
8,390,420 B2	3/2013	Zuchek et al.
8,426,777 B2	4/2013	Elston et al.
8,555,776 B2	10/2013	Debord et al.
8,637,797 B2	1/2014	Imura
8,766,144 B2	7/2014	McLoughlin et al.
8,931,400 B1	1/2015	Allen
9,017,751 B2	4/2015	Rauh
9,041,799 B2	5/2015	Bielstein
9,069,340 B2	6/2015	Minvielle
9,149,058 B2	10/2015	Bilet et al.
D750,419 S *	3/2016	Hu D7/354
9,341,522 B2	5/2016	Kitzman et al.
9,414,444 B2	8/2016	Libman et al.
9,460,633 B2	10/2016	Minvielle
9,494,322 B2	11/2016	Luckhardt et al.
9,528,972 B2	12/2016	Minvielle
9,564,064 B2	2/2017	Minvielle
9,644,847 B2	5/2017	Bhogal et al.
9,933,166 B2	4/2018	Matarazzi et al.
D817,068 S *	5/2018	Eades D7/354
D821,804 S *	7/2018	Wessels D7/354
10,024,736 B2	7/2018	Nivala et al.
10,057,946 B2	8/2018	Mills et al.
10,085,584 B2	10/2018	Johncock et al.

(56) **References Cited**
U.S. PATENT DOCUMENTS

3,453,997 A	7/1969	Klepzig
3,681,568 A	8/1972	Schaefer
3,751,305 A	8/1973	Huebscher
3,786,220 A	1/1974	Harnden
3,911,893 A	10/1975	Baker et al.
4,355,912 A	10/1982	Haak
4,363,957 A	12/1982	Tachikawa et al.
4,399,351 A	8/1983	Koff
4,415,790 A	11/1983	Diesch et al.
4,453,835 A	6/1984	Clawson et al.
4,598,581 A	7/1986	Brekke
4,817,510 A	4/1989	Kowalics et al.

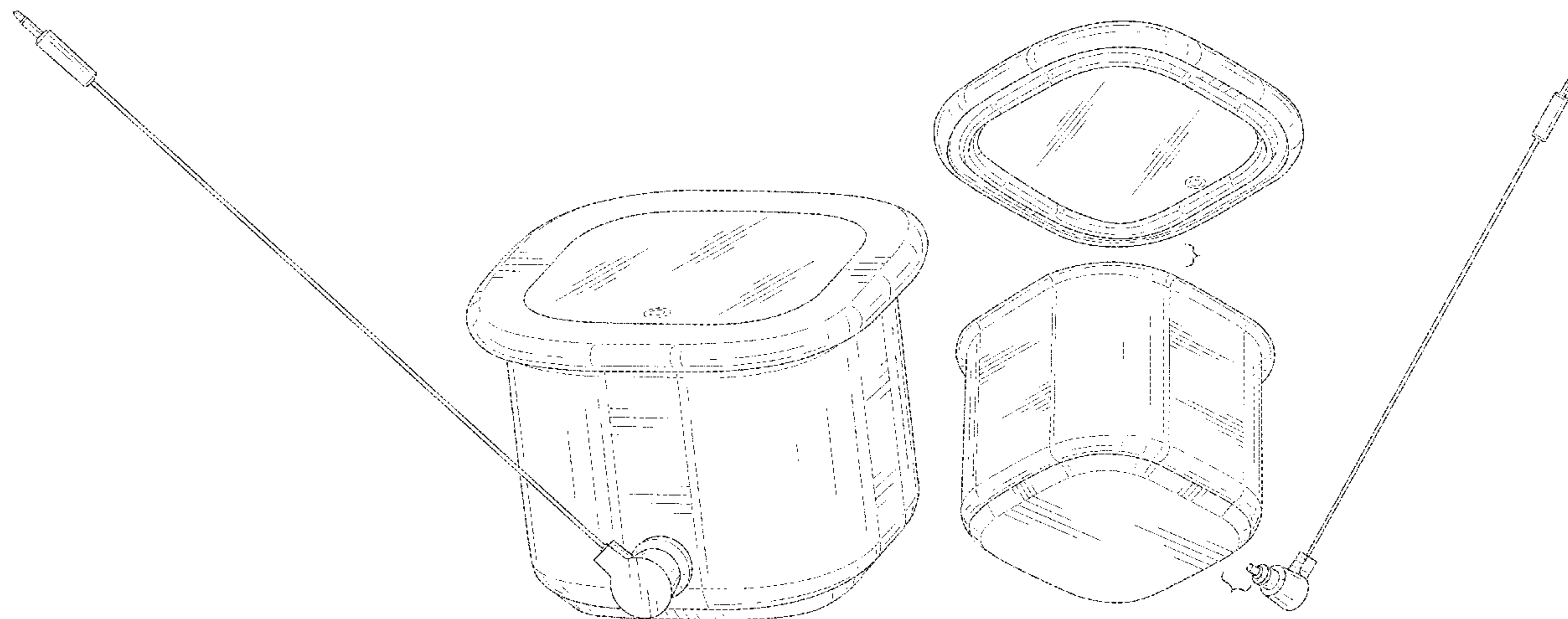

US D978,600 S

10,092,129	B2	10/2018	Jenkins et al.	2019/0254471	A1	8/2019	Reinhard-Herrscher et al.
10,455,982	B2	10/2019	Magnouloux et al.	2019/0343339	A1	11/2019	Ikuta
10,559,186	B2	2/2020	Allen	2020/0063978	A1	2/2020	Erbe et al.
D887,198	S *	6/2020	Zhao D7/354	2020/0069103	A1	3/2020	Baldwin et al.
2003/0139843	A1	7/2003	Hu et al.	FOREIGN PATENT DOCUMENTS			
2005/0046584	A1	3/2005	Breed	CN	1900858	A	1/2007
2005/0193901	A1	9/2005	Buehler	CN	101504158	A	8/2009
2006/0185523	A1	8/2006	Wiedemann et al.	CN	201353794	Y	12/2009
2006/0218057	A1	9/2006	Fitzpatrick et al.	CN	202392848	U	8/2012
2007/0001012	A1	1/2007	Kim et al.	CN	103234228	A	8/2013
2007/0007279	A1	1/2007	Chun et al.	CN	103592227	A	2/2014
2007/0029306	A1	2/2007	Chun et al.	CN	104042124	A	9/2014
2007/0042091	A1	2/2007	Rund et al.	CN	203914599	U	11/2014
2007/0053407	A1	3/2007	Kinsler	DE	19828333	A1	12/1999
2007/0215599	A1	9/2007	Kahler	DE	202008000135		3/2008
2008/0029078	A1	2/2008	Baumann et al.	DE	102008043722	A1	5/2010
2008/0043809	A1	2/2008	Herbert	DE	102012204229	A1	9/2013
2008/0120188	A1	5/2008	Mobley et al.	DE	102017220884	A1	5/2019
2008/0274240	A1	11/2008	Germouni et al.	EP	0298858	A1	1/1989
2009/0274805	A1	11/2009	Schonemann	EP	0899512	A1	3/1999
2010/0006558	A1	1/2010	McLoughlin et al.	EP	1179711	A1	2/2002
2010/0021606	A1	1/2010	Rauh	EP	1746350	A2	1/2007
2010/0134620	A1	6/2010	Bielstein	EP	2149755	A1	2/2010
2010/0138075	A1	6/2010	Boer et al.	EP	2618634	A1	7/2013
2010/0145483	A1	6/2010	McGonagle et al.	FR	2942162	A1	8/2010
2010/0147823	A1	6/2010	Anderson et al.	GB	1163509	A	9/1969
2010/0320189	A1	12/2010	Buchheit	GB	1195750	A	6/1970
2011/0002677	A1	1/2011	Cochran et al.	GB	1334550	A	10/1973
2011/0003048	A1	1/2011	Sugimoto et al.	GB	2400660	A	10/2004
2011/0284518	A1	11/2011	Elston et al.	JP	H07313341	A	12/1995
2012/0017882	A1	1/2012	Kitaguchi et al.	JP	11-63509		3/1999
2012/0038549	A1	2/2012	Mandella et al.	JP	2004187778	A	7/2004
2012/0100269	A1	4/2012	Polt	JP	2005276171	A	10/2005
2012/0170247	A1	7/2012	Do	JP	2010099417	A	5/2010
2012/0288595	A1	11/2012	Randall et al.	JP	201353794		3/2013
2013/0052310	A1	2/2013	Stanford	JP	2019519779	A	7/2019
2013/0084369	A1	4/2013	Smrke	KR	101436279	B1	8/2014
2013/0092680	A1	4/2013	Cartwright et al.	WO	2006128696	A1	12/2006
2013/0092682	A1	4/2013	Mills et al.	WO	2007022507	A2	2/2007
2013/0171304	A1	7/2013	Huntley	WO	2009012874	A2	1/2009
2013/0176116	A1	7/2013	Jung et al.	WO	2013167333	A1	11/2013
2013/0269539	A1	10/2013	Polt	WO	2014086486	A2	6/2014
2013/0277353	A1	10/2013	Joseph et al.	WO	2014086487	A1	6/2014
2013/0306627	A1	11/2013	Libman et al.	WO	2015059931	A1	4/2015
2014/0026762	A1	1/2014	Riefenstein	WO	2016077360	A1	5/2016
2014/0086274	A1	3/2014	Henke	OTHER PUBLICATIONS			
2014/0199455	A1	7/2014	Bilet et al.	U.S. Appl. No. 12/216,999, filed Jul. 14, 2008, Kim, et al.			
2014/0203012	A1	7/2014	Corona et al.	U.S. Appl. No. 13/059,486, filed Aug. 26, 2009, Sakane, et al.			
2014/0297467	A1	10/2014	Soller et al.	U.S. Appl. No. 13/978,413, filed Apr. 19, 2012, Ruther.			
2014/0348987	A1	11/2014	Cheng et al.	U.S. Appl. No. 14/205,587, filed Mar. 12, 2014, Chadwick, et al.			
2015/0056344	A1	2/2015	Luckhardt	U.S. Appl. No. 14/205,593, filed Mar. 12, 2014, Chadwick, et al.			
2015/0136760	A1	5/2015	Lima et al.	U.S. Appl. No. 15/510,544, filed Oct. 9, 2015, Kondo, et al.			
2015/0185093	A1	7/2015	Kitzman et al.	"Electrolux launches CombiSteam Pro Smart", http://www.homeappliancesworld.com/2018/03/08/electrolux-launches-combisteam-pro-smart/ , downloaded from internet on Jan. 18, 2019, 2 pages.			
2015/0208858	A1	7/2015	Robbins et al.	Automated Fruit Recognition for Super Markets and Food Stores, Fraunhofer, http://www.iosb.fraunhofer.de/servlet/is/33328/ , accessed online Nov. 13, 2014.			
2015/0285513	A1	10/2015	Matarazzi et al.	Fang, Chi et al. "Cooking Time Optimization on Given Machine Constraints and Order Constraints" Integer Programming Approach, Dec. 17, 2016.			
2015/0289324	A1	10/2015	Rober et al.	https://www.greatgrubdelicioustreats.com/fried-egg-grilled-cheese-sandwich/ ; "Great Grub, Delicious Treats"; Nov. 29, 2015; download date Apr. 13, 2021; pp. 1-24.			
2016/0014849	A1	1/2016	Hegedis et al.	International Search Report and Written Opinion for application No. PCT/US2020/066014 dated Mar. 12, 2021.			
2016/0098465	A1	4/2016	Wu et al.	Karimi, Davood "Deep learning with noisy labels: exploring techniques and remedies in medical image analysis" arXiv:1912.02911v4 [cs.CV] Mar. 20, 2020.			
2016/0242240	A1	8/2016	Lee et al.	Sun, Da-Wen; "Computer Vision Technology For Food Quality Evaluation", Second Edition, Academic Press, 2016.			
2016/0278563	A1	9/2016	Choudhary				
2016/0283822	A1	9/2016	Imai et al.				
2016/0367073	A1	12/2016	Smith				
2017/0011649	A1	1/2017	Lee et al.				
2017/0074522	A1	3/2017	Cheng				
2017/0116661	A1	4/2017	Sundaram				
2017/0132950	A1	5/2017	Harrison				
2017/0138798	A1	5/2017	Brown et al.				
2017/0142780	A1	5/2017	Hoare et al.				
2017/0150842	A1	6/2017	Young et al.				
2017/0224161	A1	8/2017	Li et al.				
2017/0332841	A1	11/2017	Reischmann				
2018/0101608	A1	4/2018	Thysell				
2018/0310747	A1	11/2018	Wang et al.				
2018/0324908	A1	11/2018	Denker et al.				
2019/0017880	A1	1/2019	Smith				
2019/0110628	A1	4/2019	Lee et al.				
2019/0110638	A1	4/2019	Li et al.				
2019/0234617	A1	8/2019	Bhagal et al.				
2019/0250043	A1	8/2019	Wu et al.				

European Search Report Application No. 16 790 106.5, dated Aug. 2, 2019.

Li, Xin, et al., "On-Line Temperature Estimation for Noisy Thermal Sensors Using a Smoothing Filter-Based Kalman Predictor", *Sensors*, 2018, 18, 433, www.mdpi.com/journal/sensors.

* cited by examiner

Primary Examiner — Ricky Pham

(74) *Attorney, Agent, or Firm* — Jeffrey Schox; Diana Lin

(57) **CLAIM**

We claim the ornamental design for a cooking vessel, as shown and described.

DESCRIPTION

FIG. 1 is an isometric view, from the front top left, of a first embodiment of the cooking vessel.

FIG. 2 is an isometric view, from the back bottom right, of the first embodiment of the cooking vessel.

FIG. 3 is a plan view from the top of the first embodiment of the cooking vessel.

FIG. 4 is a plan view from the bottom of the first embodiment of the cooking vessel.

FIG. 5 is an elevation view from the front of the first embodiment of the cooking vessel.

FIG. 6 is an elevation view from the back of the first embodiment of the cooking vessel.

FIG. 7 is an elevation view from the right of the first embodiment of the cooking vessel.

FIG. 8 is an elevation view from the left of the first embodiment of the cooking vessel.

FIG. 9 is an isometric view, from the back bottom right, of the second embodiment of the cooking vessel.

FIG. 10 is an isometric view, from the front top left, of a second embodiment of the cooking vessel.

FIG. 11 is a plan view from the tops of the components of the second embodiment of the cooking vessel.

FIG. 12 is a plan view from the bottoms of the components of the second embodiment of the cooking vessel.

FIG. 13 is an elevation view from the front of the second embodiment of the cooking vessel.

FIG. 14 is an elevation view from the back of the second embodiment of the cooking vessel.

FIG. 15 is an elevation view from the right of the second embodiment of the cooking vessel;

FIG. 16 is an elevation view from the left of the second embodiment of the cooking vessel; and,

FIG. 17 is a cross-sectional view taken through line 17-17 of FIG. 3.

Any broken lines are understood to be for illustrative purposes only and form no part of the claimed design.

1 Claim, 17 Drawing Sheets

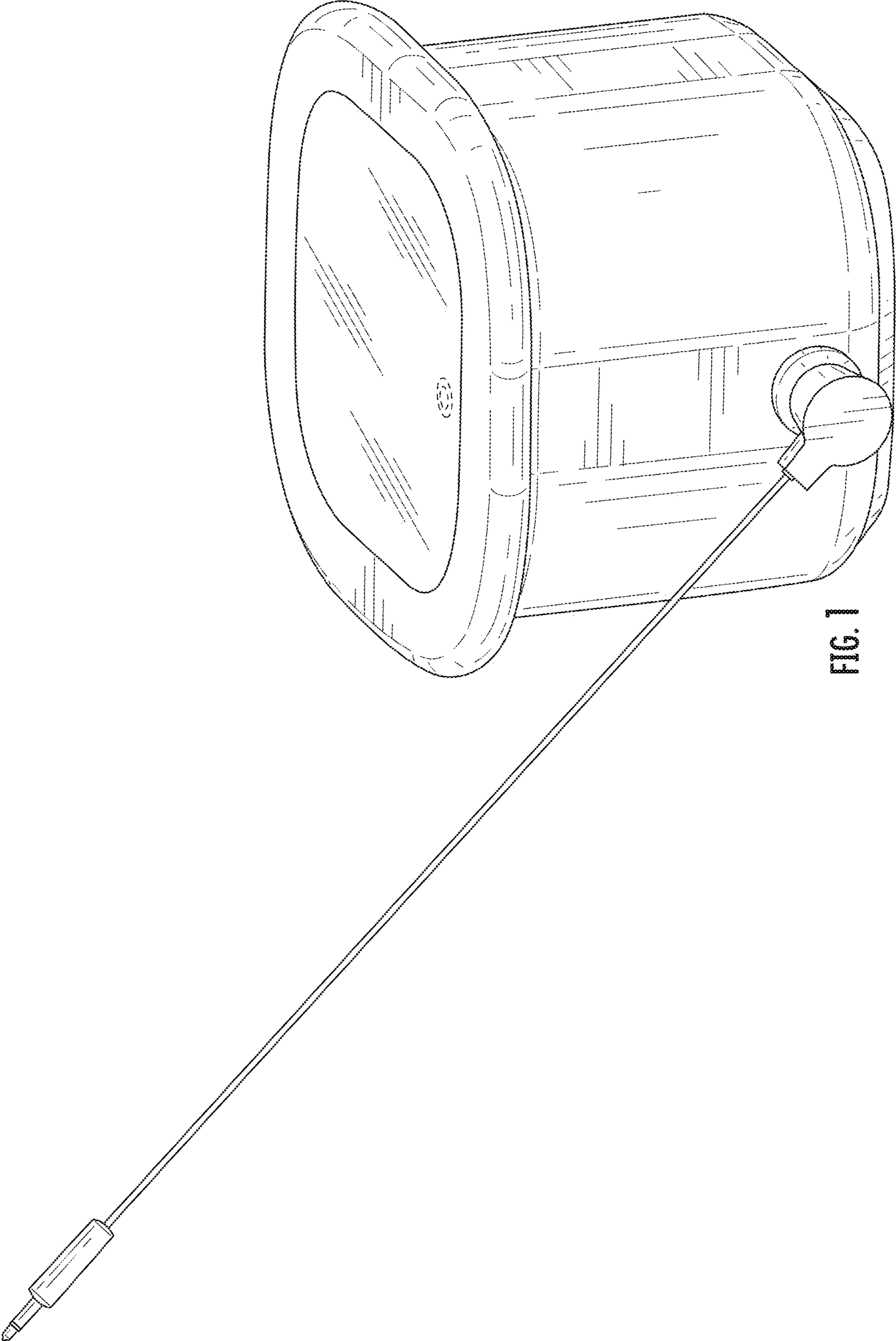

FIG. 1

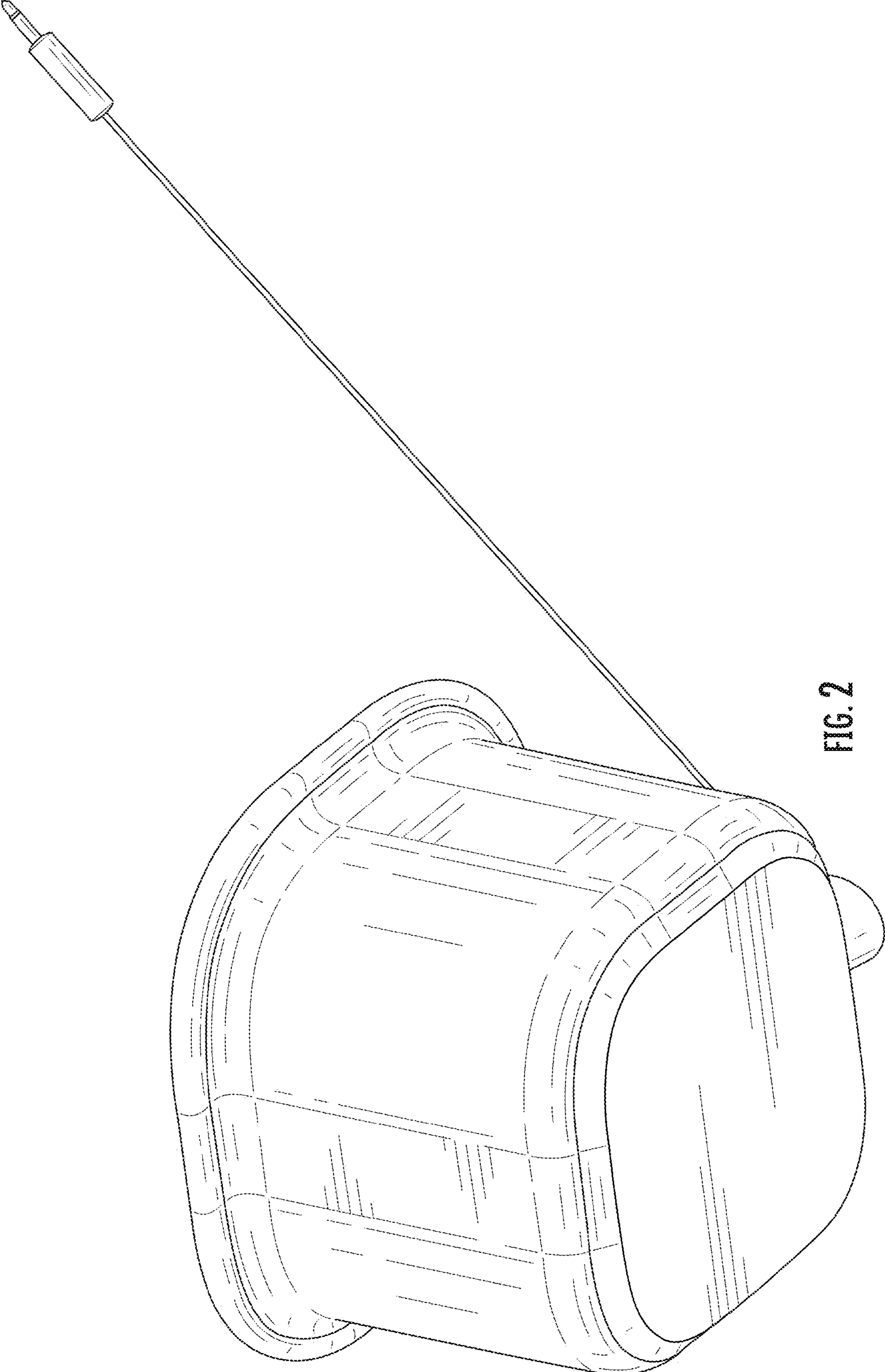
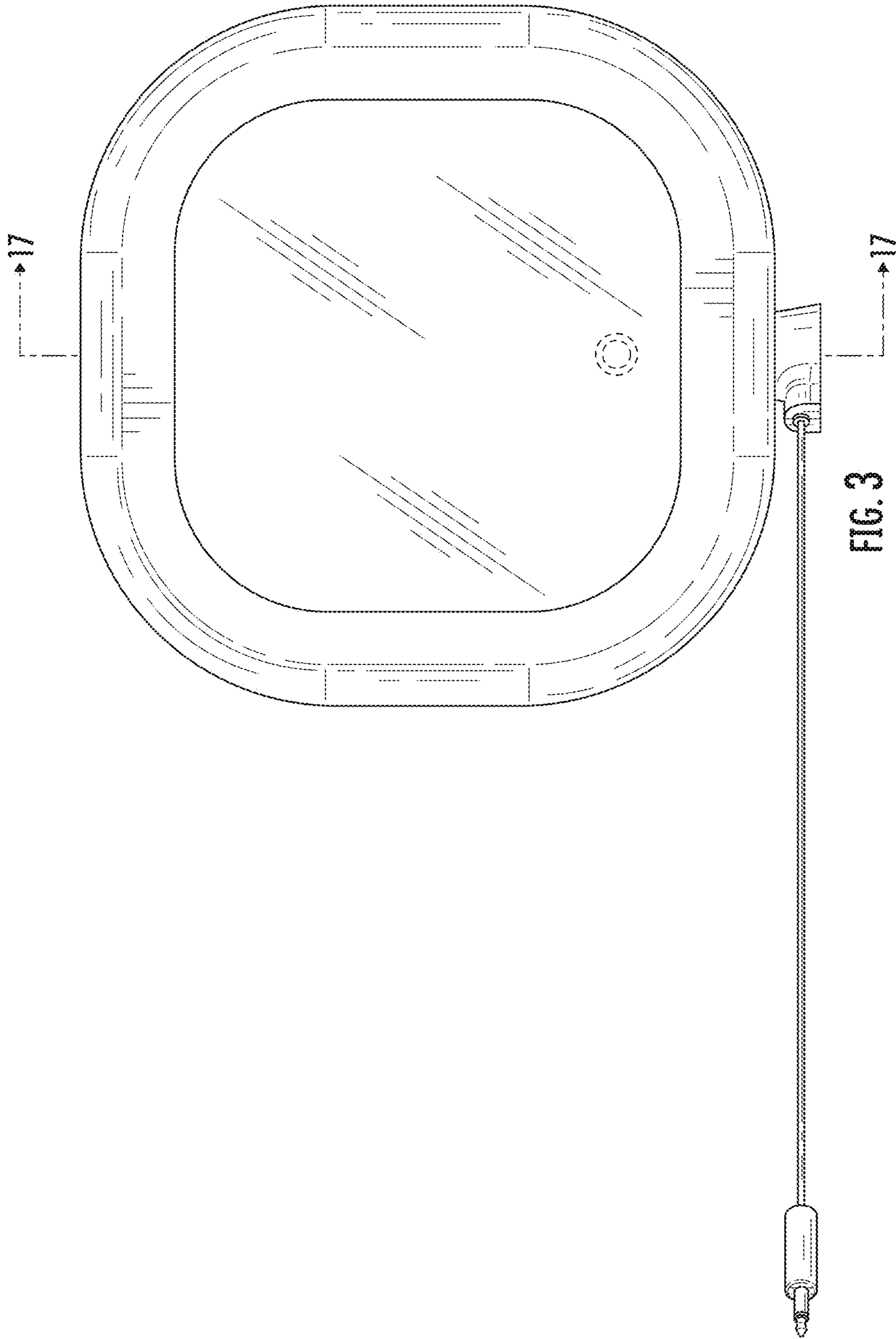

FIG. 2



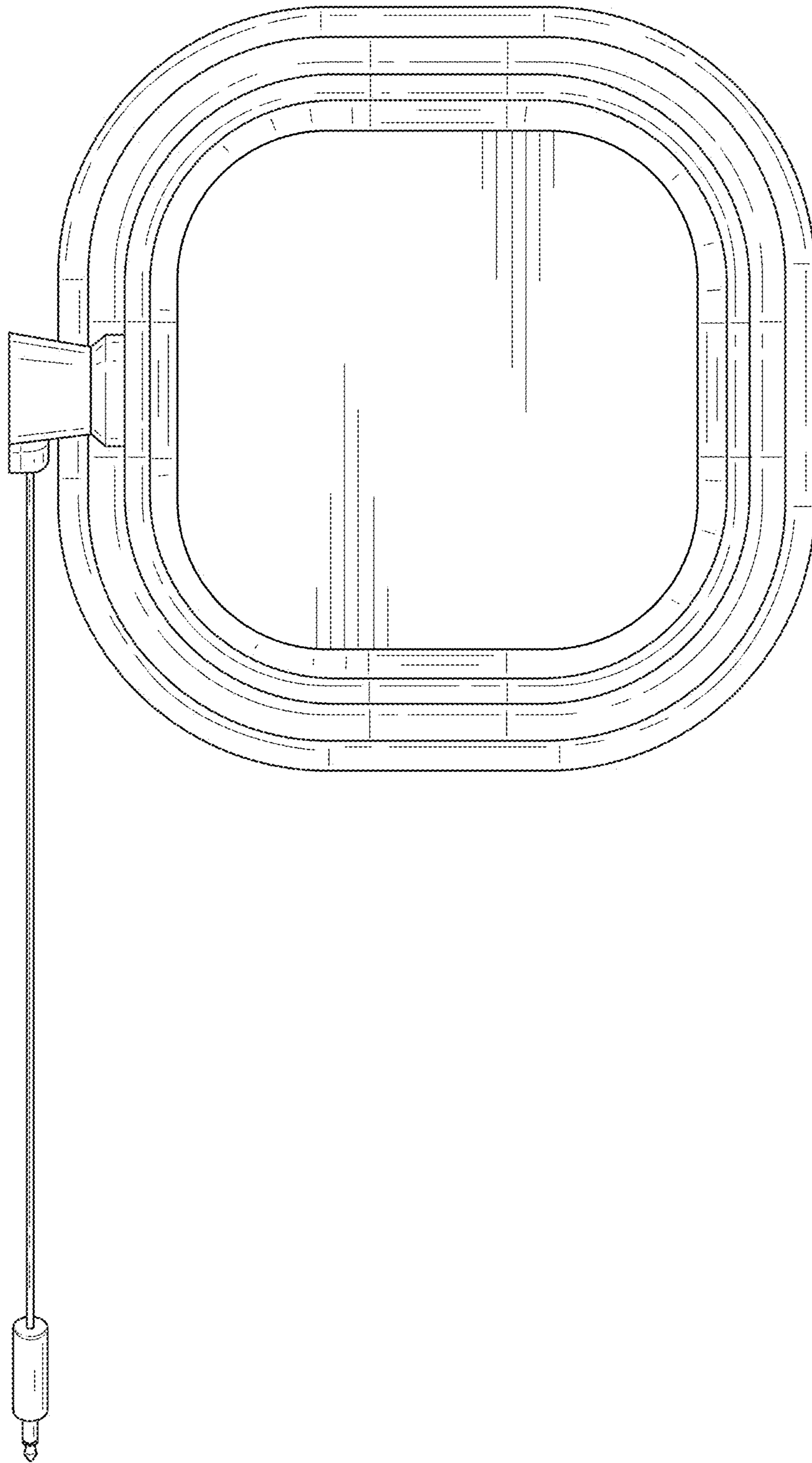

FIG. 4

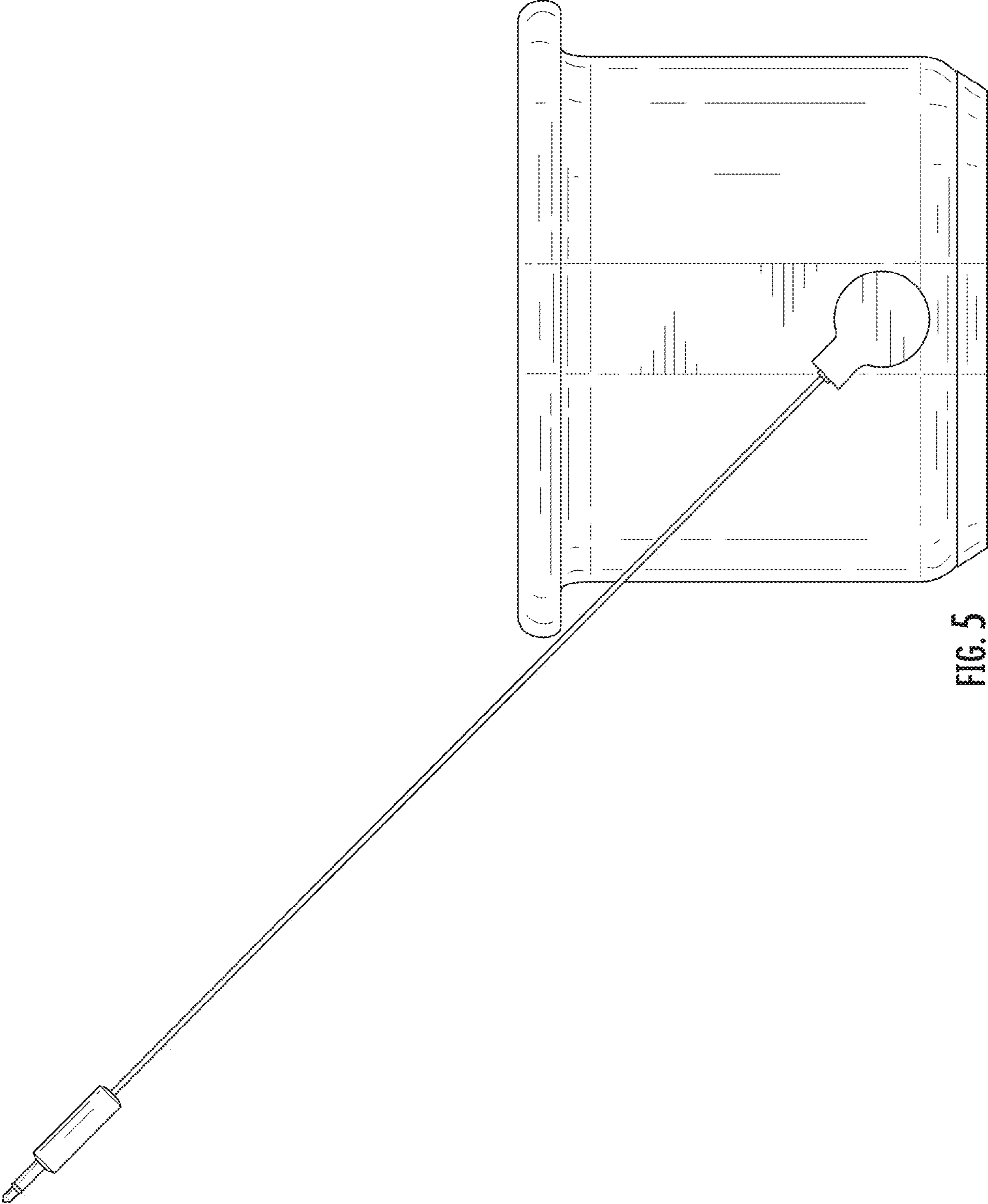
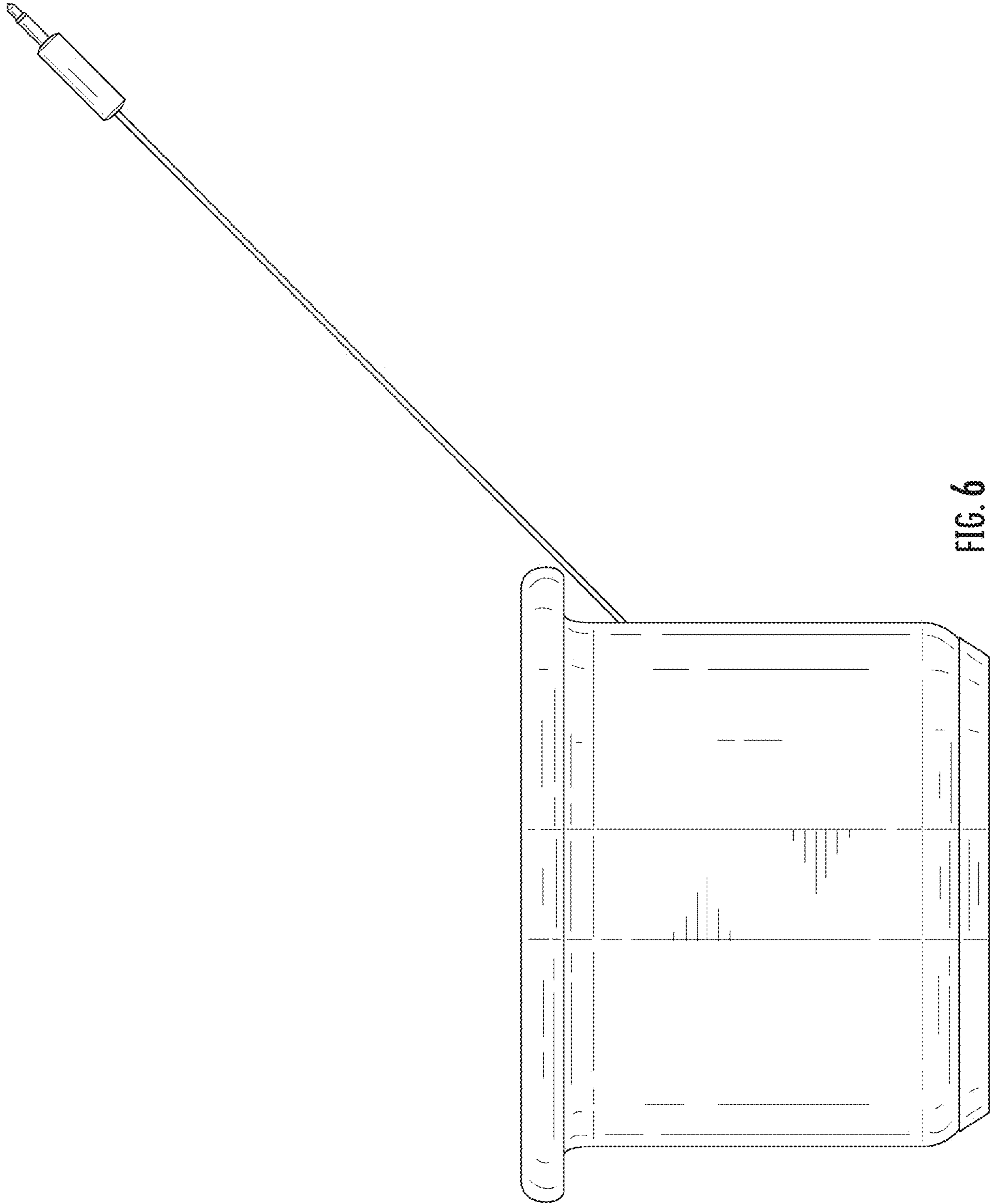

FIG. 5



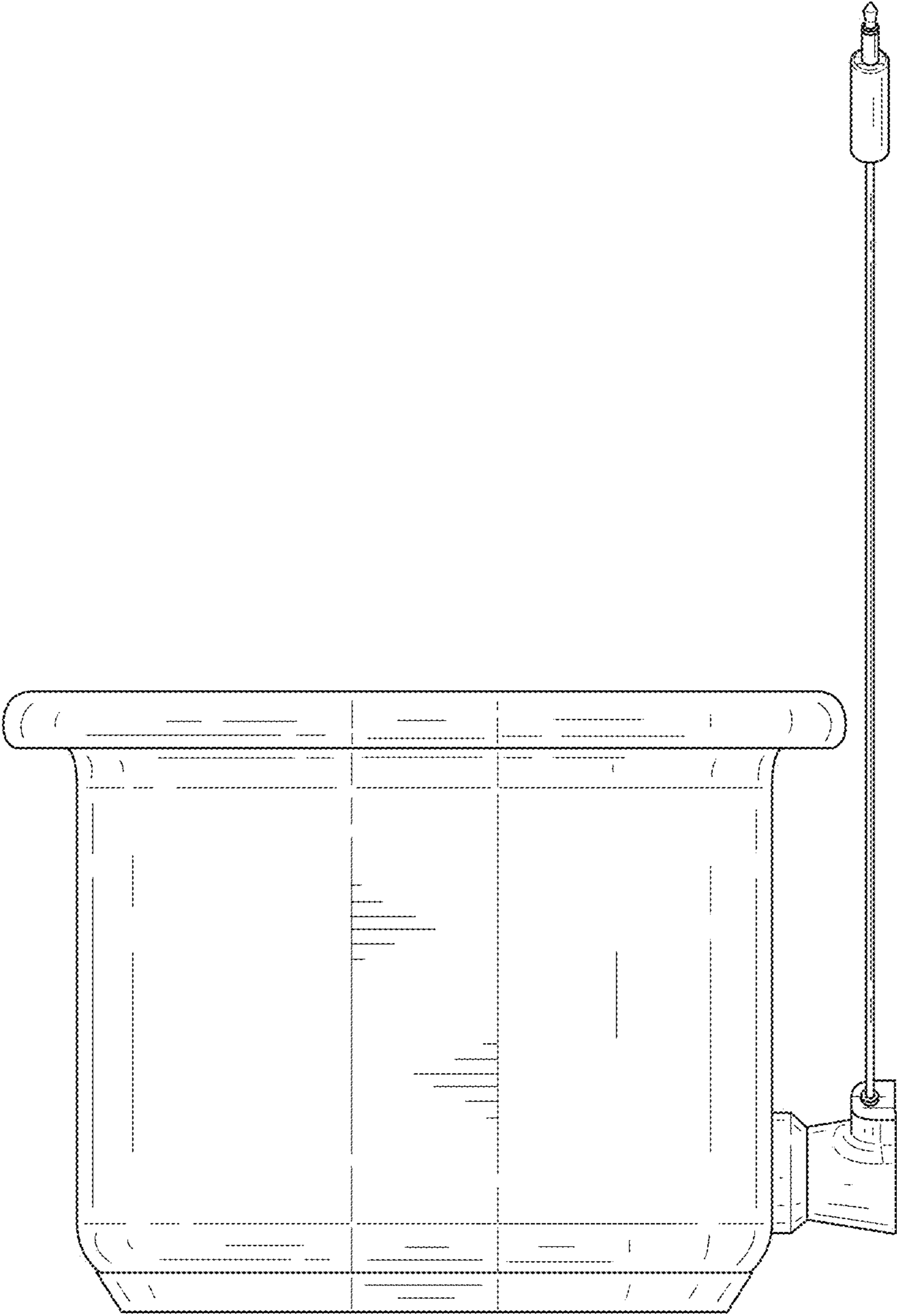

FIG. 7

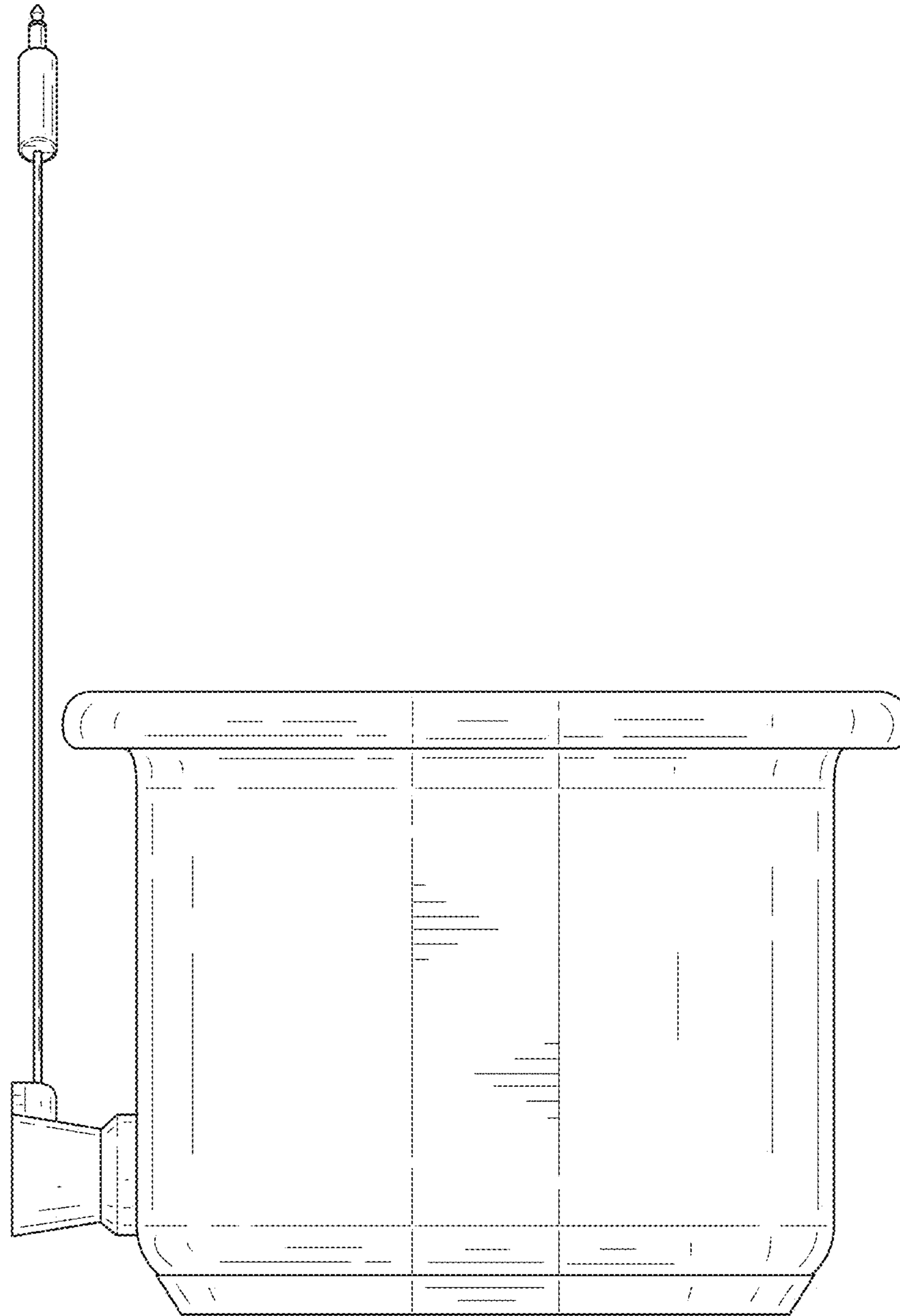

FIG. 8

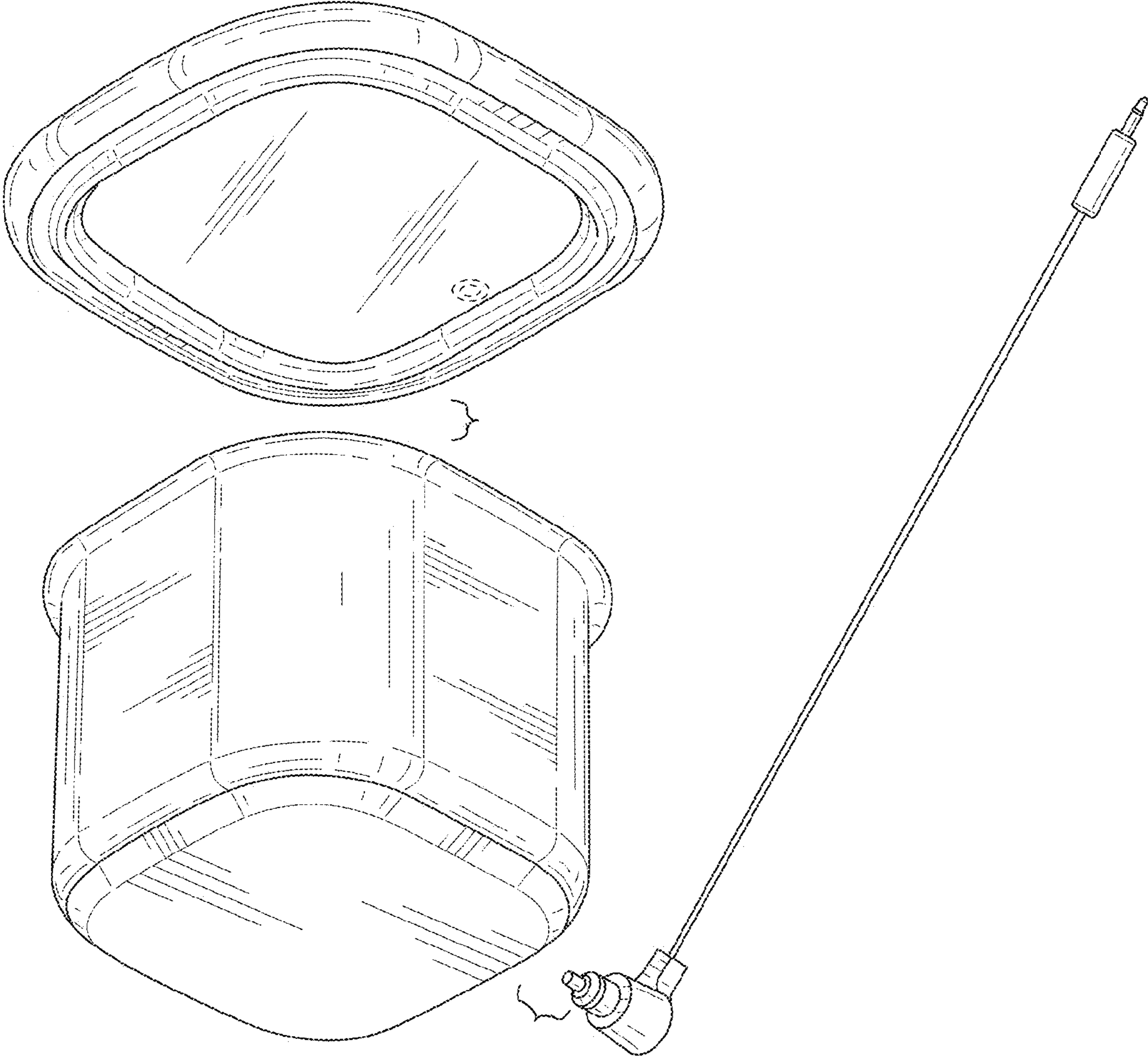

FIG. 9

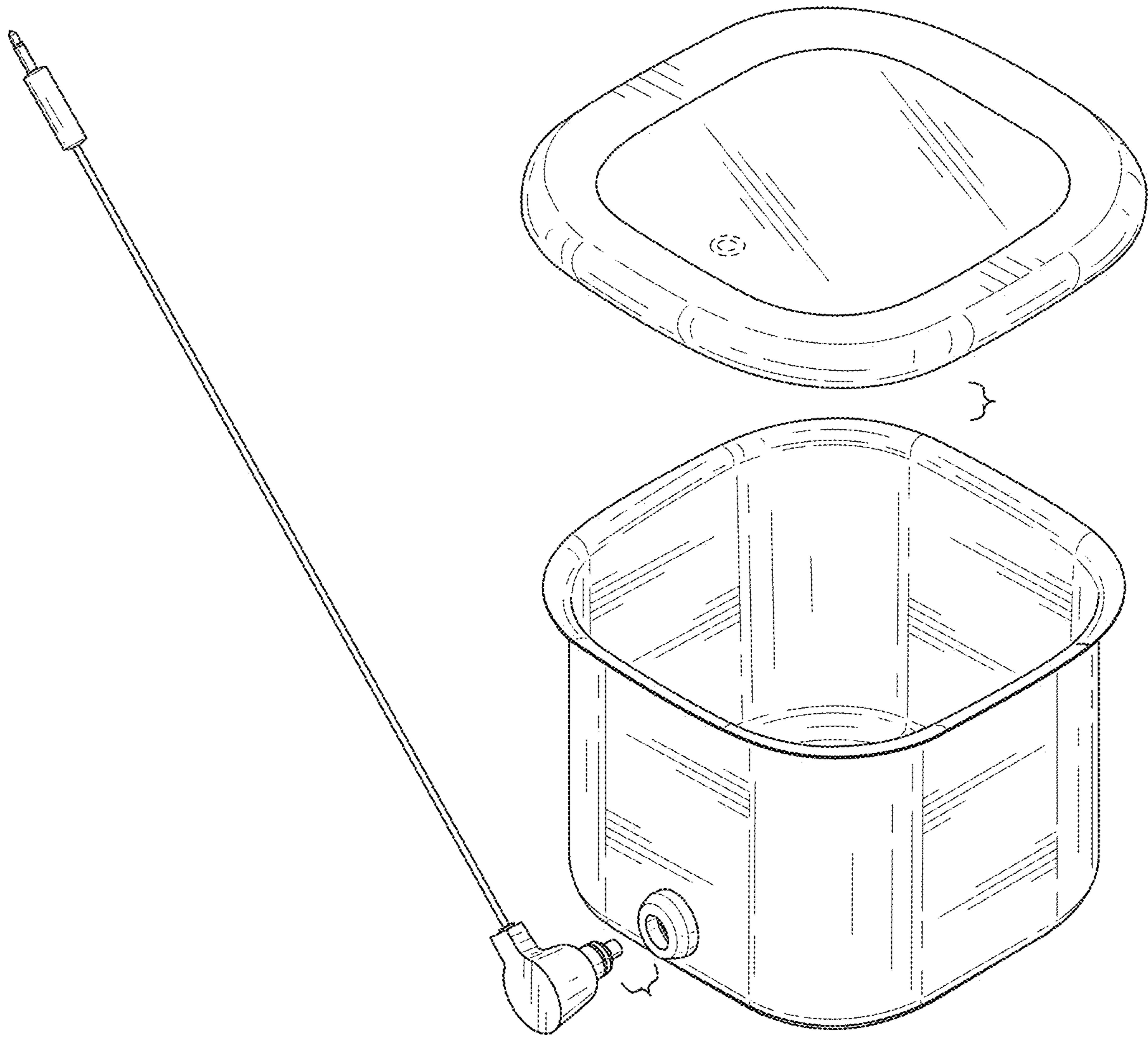

FIG. 10

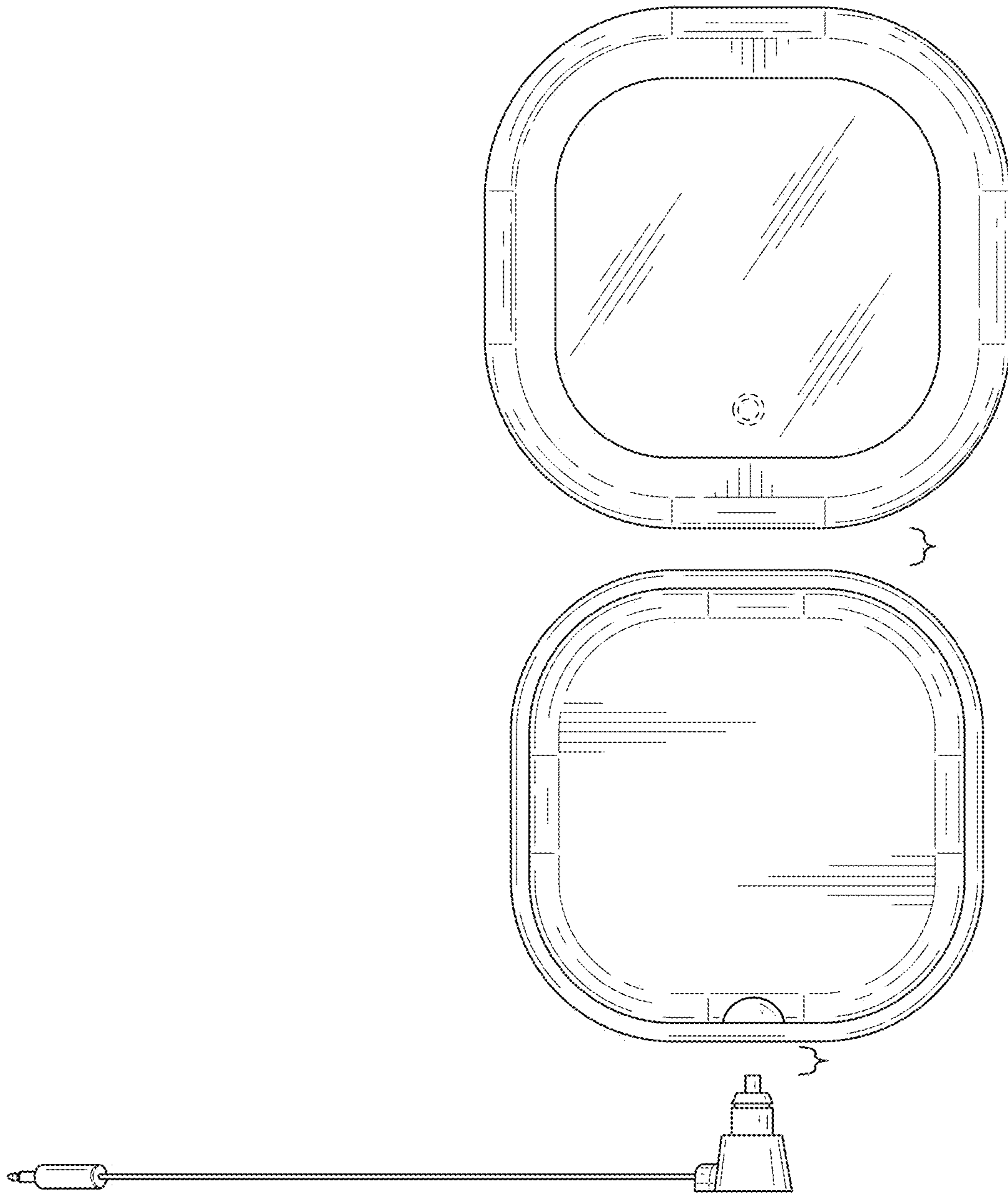

FIG. 11

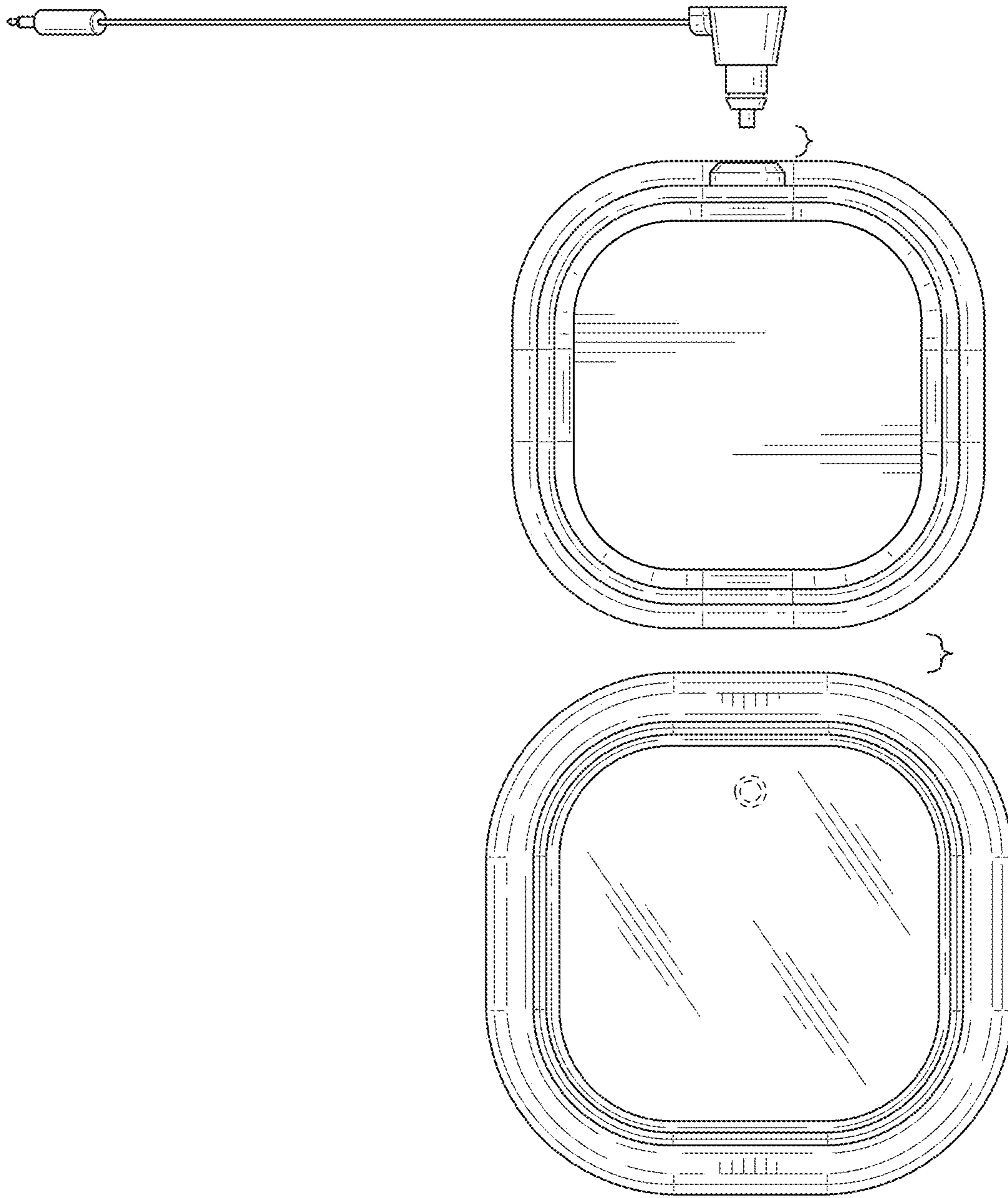

FIG. 12

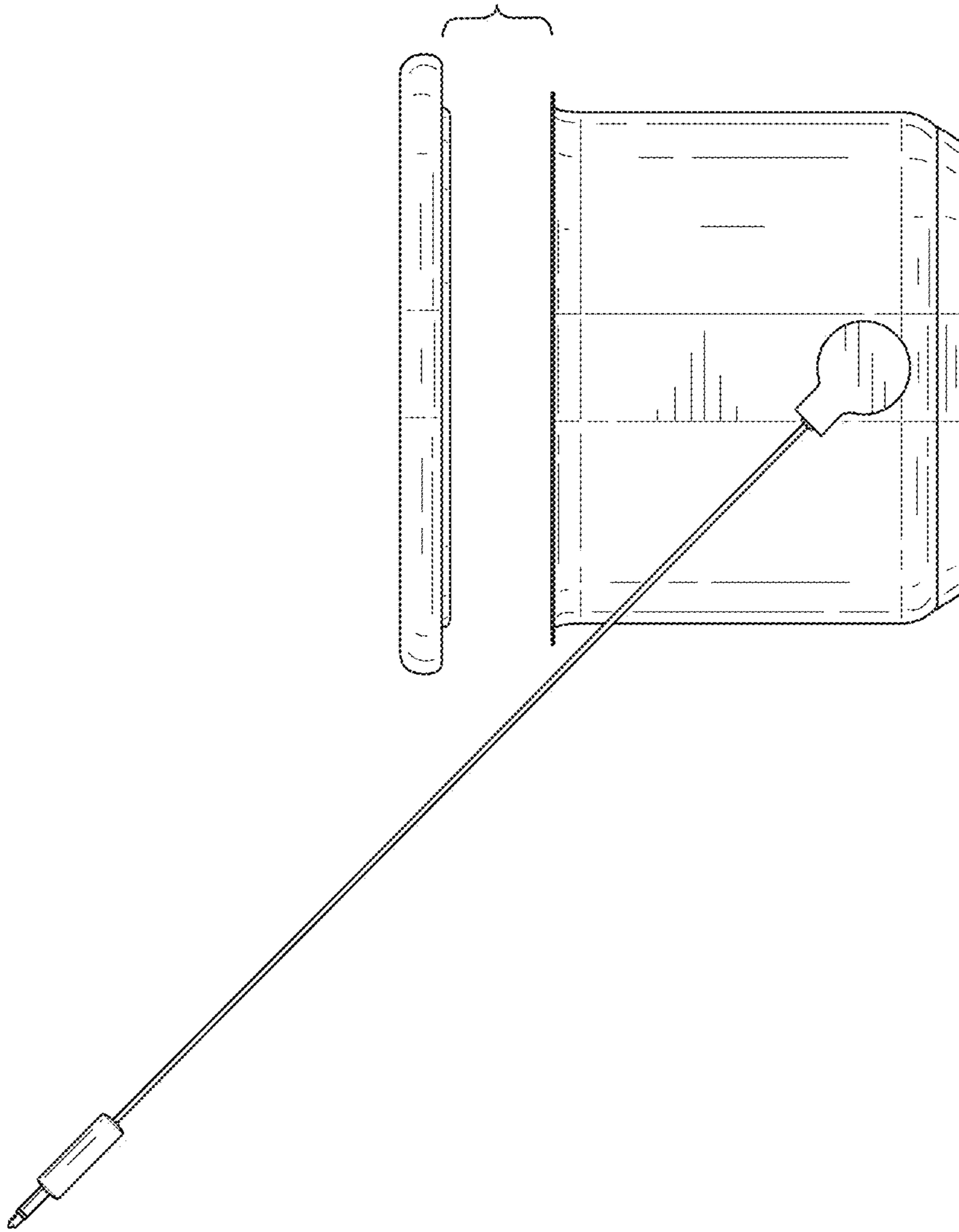

FIG. 13

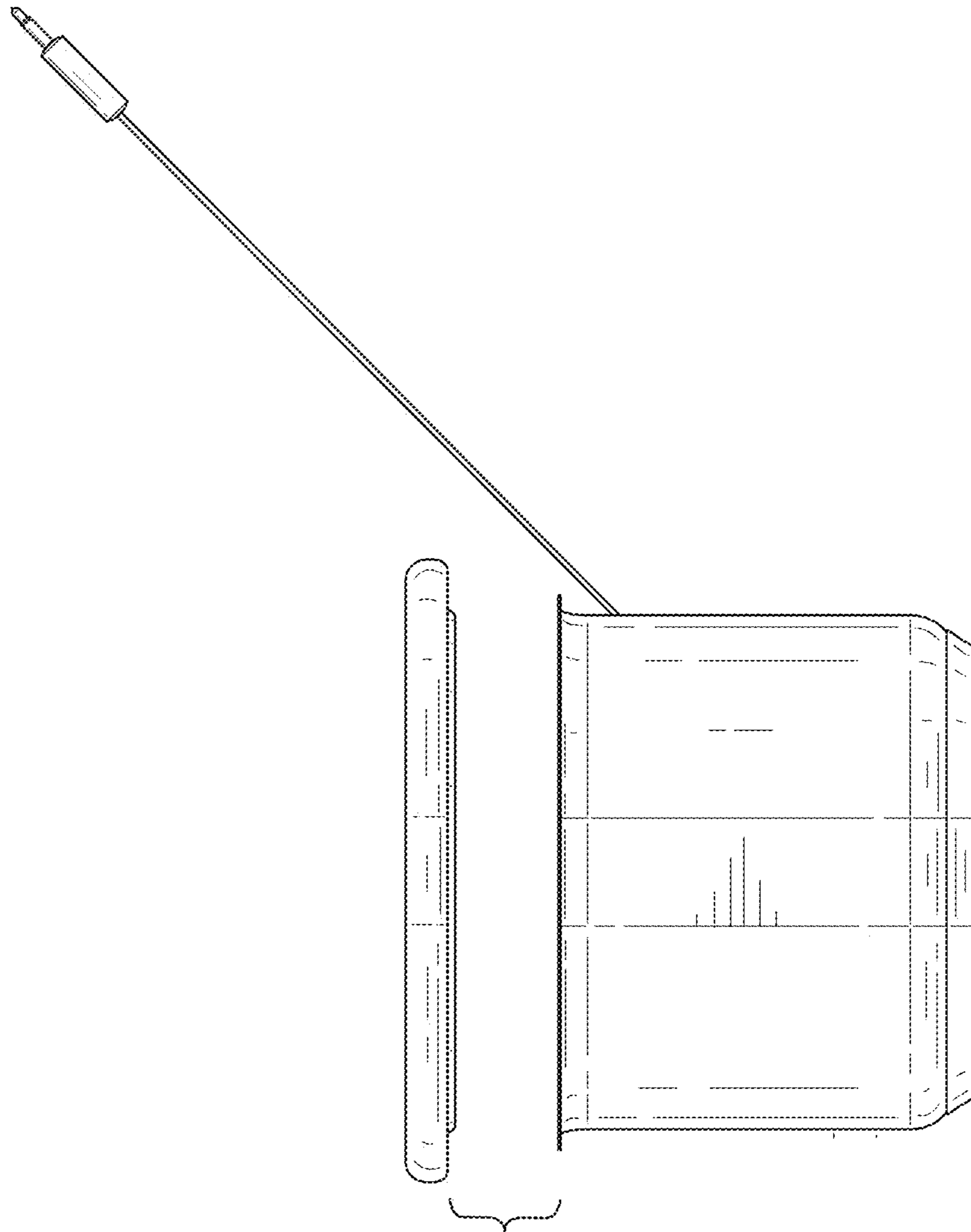

FIG. 14

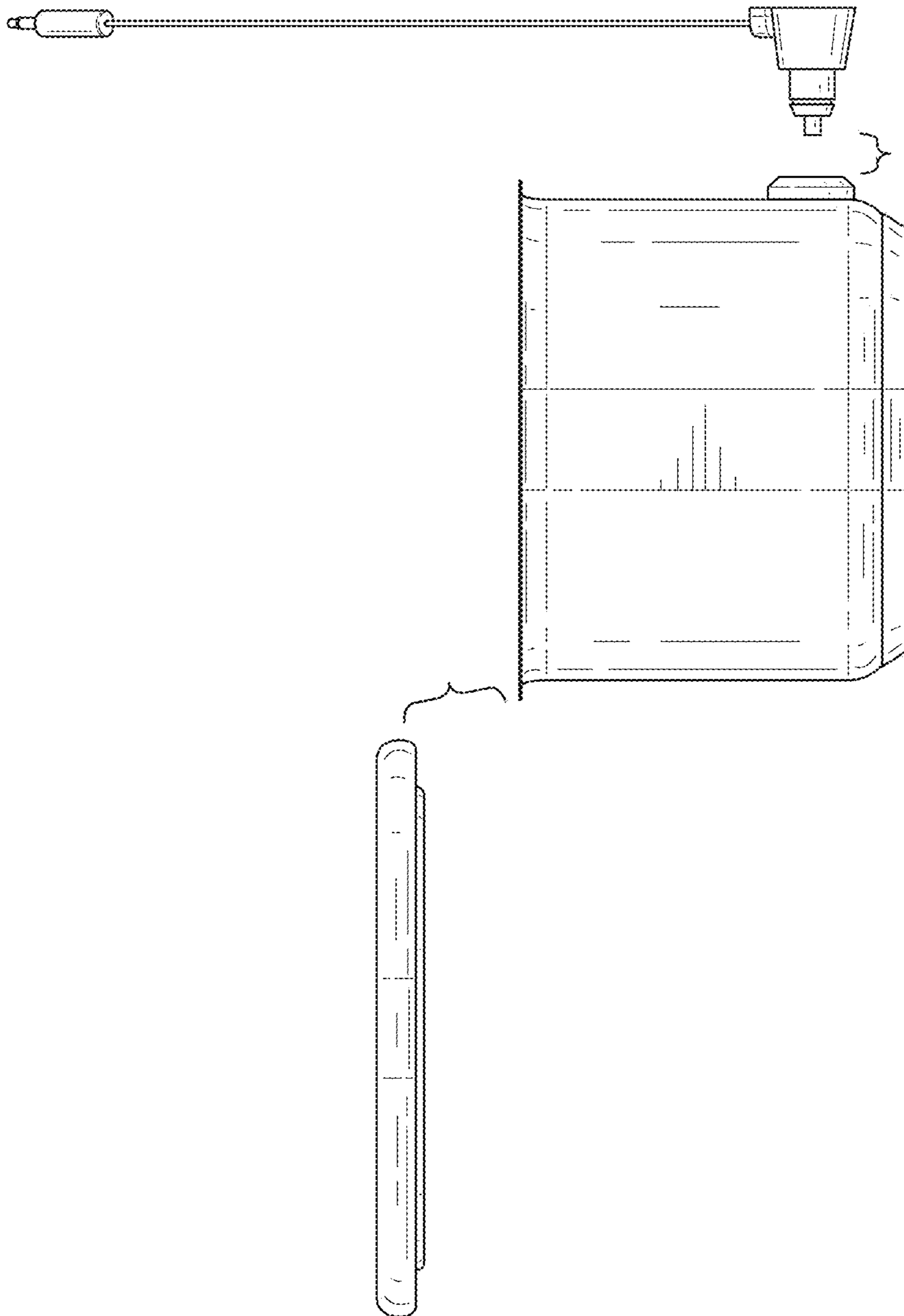

FIG. 15

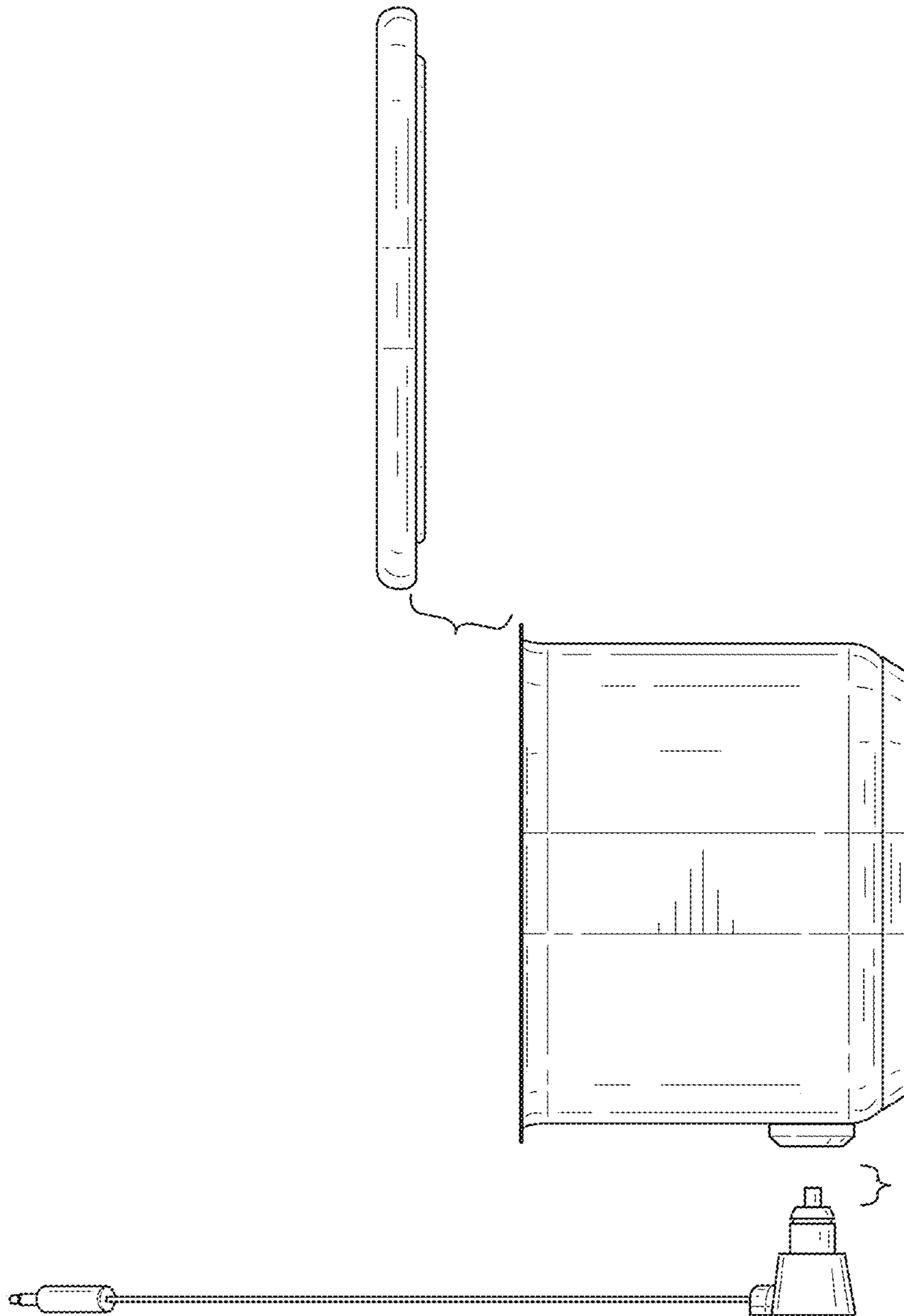

FIG. 16

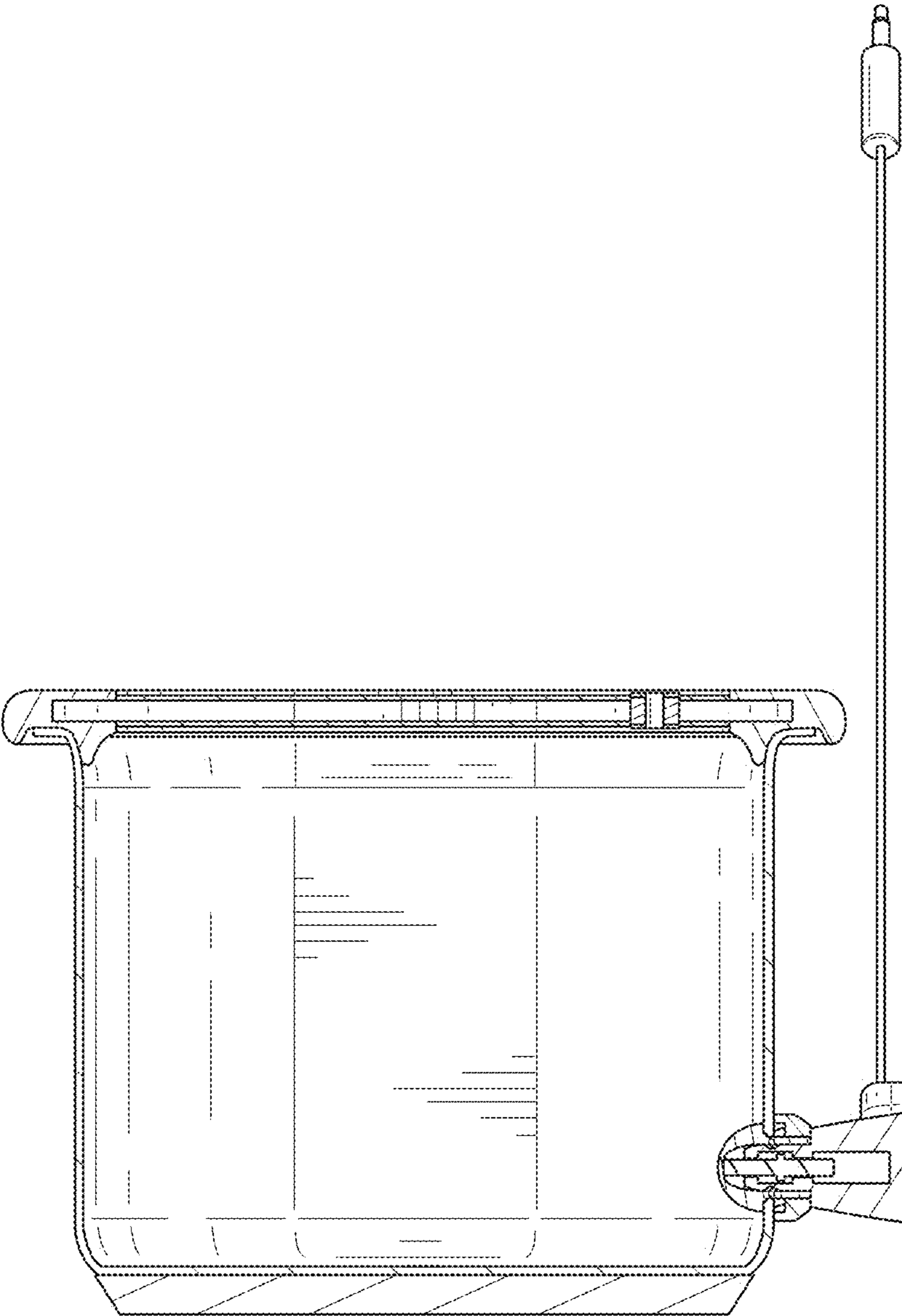

FIG. 17