



US00D978346S

(12) **United States Design Patent** (10) **Patent No.:** **US D978,346 S**
Reis et al. (45) **Date of Patent:** **** Feb. 14, 2023**

(54) **SEPARATED FINGER PAD FOR A SURGICAL SUCTION INSTRUMENT**

(74) *Attorney, Agent, or Firm* — Mark Young, PA

(71) Applicant: **BR SURGICAL, LLC**, Jacksonville, FL (US)

(57) **CLAIM**

The ornamental design for separated finger pad for a surgical suction instrument, as shown and described.

(72) Inventors: **Timothy J Reis**, Jacksonville, FL (US); **John Douglas Barrow**, Jacksonville, FL (US)

DESCRIPTION

(73) Assignee: **BR SURGICAL, LLC**, Jacksonville, FL (US)

(**) Term: **15 Years**

(21) Appl. No.: **29/866,220**

(22) Filed: **Sep. 1, 2022**

FIG. 1 is a plan view of separated finger pad for a surgical suction instrument.

FIG. 2 is a first side view of the separated finger pad for a surgical suction instrument shown in FIG. 1.

FIG. 3 is a front view of the separated finger pad for a surgical suction instrument shown in FIG. 1.

FIG. 4 is a bottom view of the separated finger pad for a surgical suction instrument shown in FIG. 1.

FIG. 5 is a rear view of the separated finger pad for a surgical suction instrument shown in FIG. 1.

FIG. 6 is a second side view of the separated finger pad for a surgical suction instrument shown in FIG. 1.

FIG. 7 is a first top perspective view of the separated finger pad for a surgical suction instrument shown in FIG. 1.

FIG. 8 is a second top perspective view of the separated finger pad for a surgical suction instrument shown in FIG. 1.

FIG. 9 is a third top perspective view of the separated finger pad for a surgical suction instrument shown in FIG. 1.

FIG. 10 is a fourth top perspective view of the separated finger pad for a surgical suction instrument shown in FIG. 1.

FIG. 11 is a first bottom perspective view of the separated finger pad for a surgical suction instrument shown in FIG. 1.

FIG. 12 is a second bottom perspective view of the separated finger pad for a surgical suction instrument shown in FIG. 1.

FIG. 13 is a third bottom perspective view of the separated finger pad for a surgical suction instrument shown in FIG. 1; and,

FIG. 14 is a fourth bottom perspective view of the separated finger pad for a surgical suction instrument shown in FIG. 1.

The broken line showing of parts of the drawings is included for the purpose of illustrating portions of a surgical suction instrument and forms no part of the claimed design.

Related U.S. Application Data

(63) Continuation of application No. 17/819,392, filed on Aug. 12, 2022.

(51) **LOC (14) Cl.** **24-02**

(52) **U.S. Cl.**
USPC **D24/133**

(58) **Field of Classification Search**
USPC D24/133, 112, 128, 129, 130, 152
(Continued)

(56) **References Cited**

U.S. PATENT DOCUMENTS

3,065,749 A 11/1962 Brass
3,625,221 A 12/1971 Corbett
(Continued)

FOREIGN PATENT DOCUMENTS

EP 3936168 A1 1/2022
WO 2016005894 A1 1/2016

Primary Examiner — Eliza Z Harvey

1 Claim, 14 Drawing Sheets

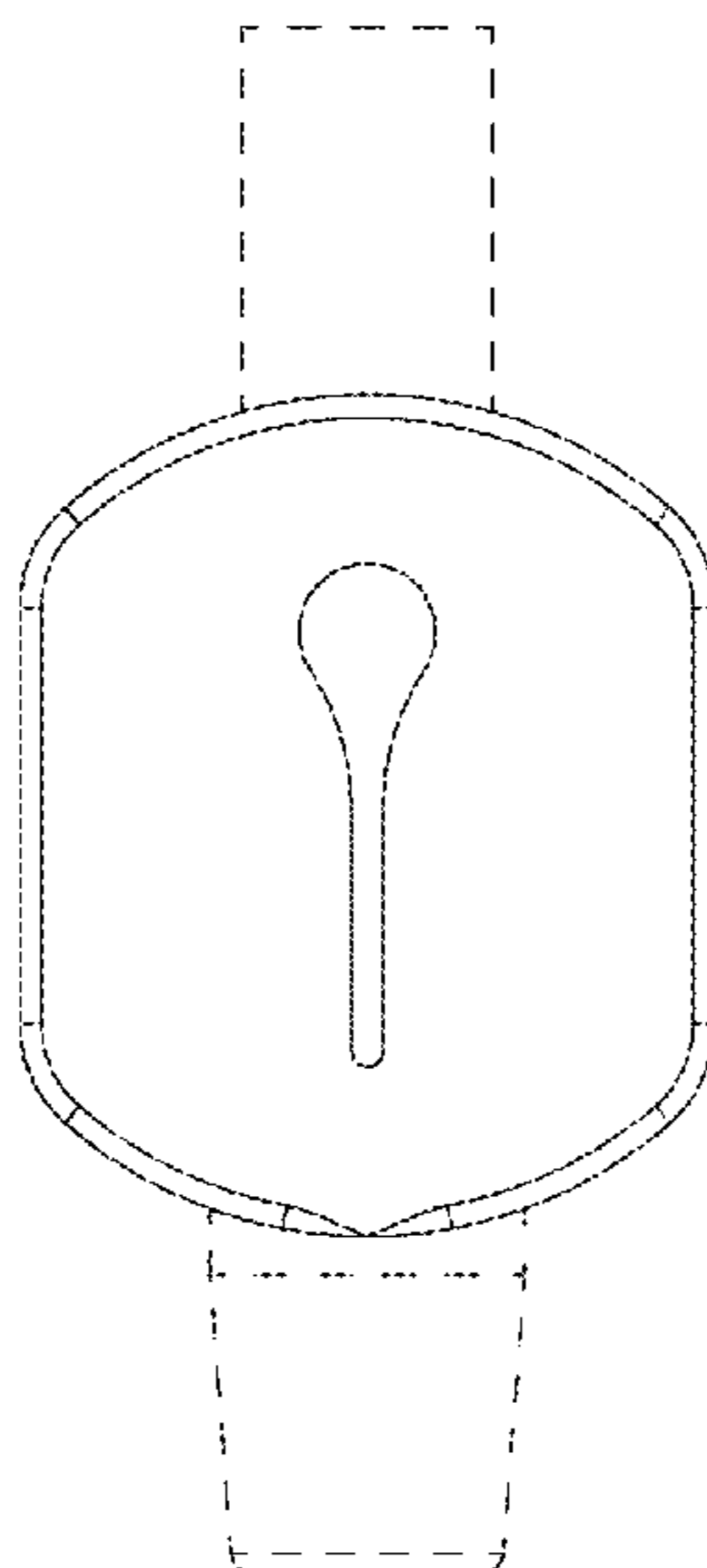

(58) **Field of Classification Search**

CPC A61M 1/87
 See application file for complete search history.

(56) **References Cited**

U.S. PATENT DOCUMENTS

3,834,388	A	9/1974	Sauer	
4,287,889	A	9/1981	Stupar	
4,299,221	A	11/1981	Phillips et al.	
4,356,823	A	11/1982	Jackson	
4,445,517	A	5/1984	Feild	
D283,641	S *	4/1986	Spetzler	D24/129
4,813,926	A	3/1989	Kerwin	
4,878,900	A *	11/1989	Sundt	A61M 1/86 D9/415
5,899,884	A	5/1999	Cover et al.	
D428,137	S *	7/2000	Phelan	D24/112
7,938,820	B2	5/2011	Webster et al.	
8,021,351	B2	9/2011	Boldenow et al.	
8,435,248	B2	5/2013	Herman	
8,915,938	B2	12/2014	Keith et al.	
8,979,888	B2	3/2015	Morriss et al.	
9,138,569	B2	9/2015	Edgren et al.	
9,233,195	B2	1/2016	Akahoshi	
9,308,127	B2	4/2016	Herman	
9,694,167	B2	7/2017	Keith et al.	
10,058,339	B2	8/2018	Galdonik et al.	
D831,200	S *	10/2018	Bergeson	D24/129
10,124,154	B2	11/2018	Evard et al.	
D901,006	S *	11/2020	Bergeson	D24/129
11,191,885	B2 *	12/2021	Arnone	A61M 1/774
11,213,308	B2	1/2022	Altman et al.	
2003/0216690	A1	11/2003	Foley	
2021/0228844	A1	7/2021	Ogle	
2021/0307770	A1	10/2021	Ridha	
2022/0096104	A1	3/2022	Ogle	

* cited by examiner

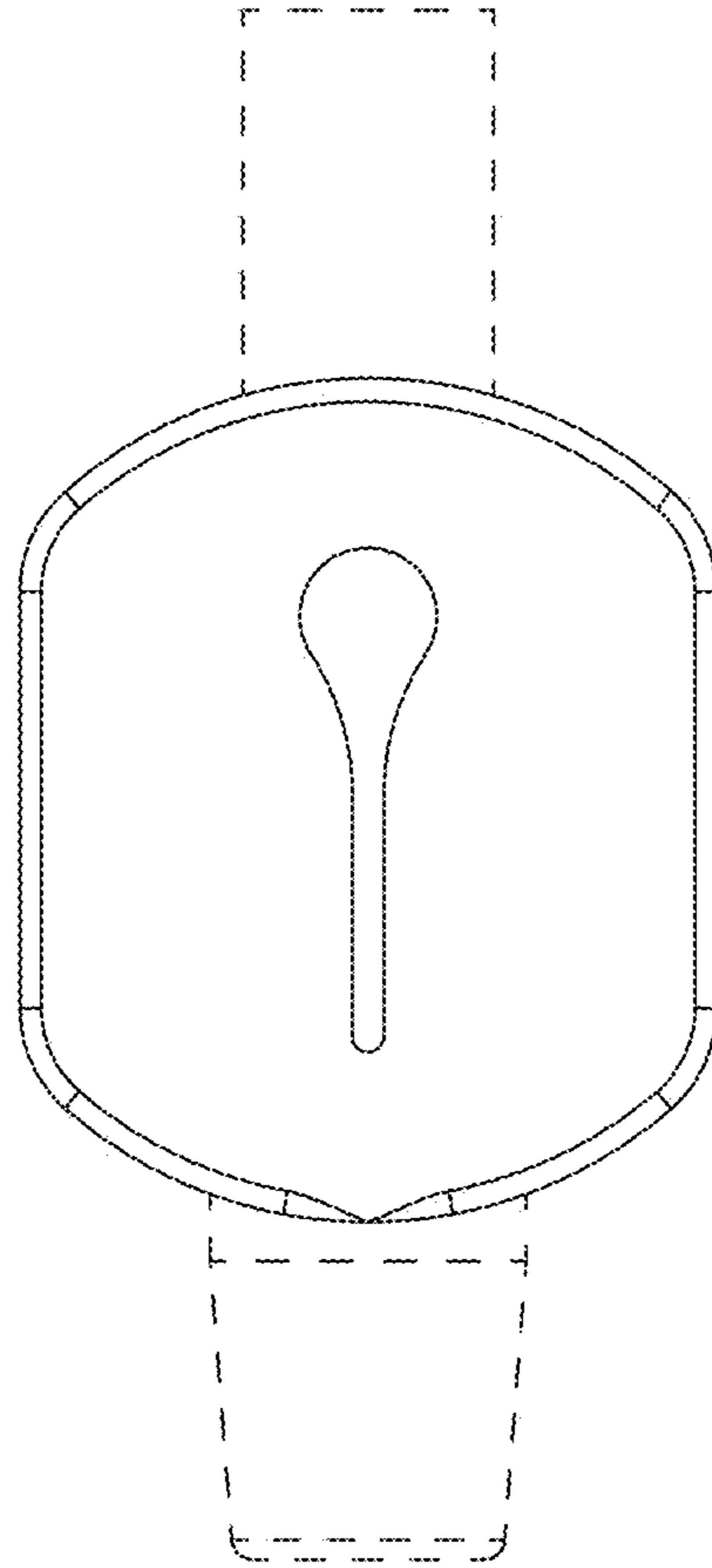

FIG. 1

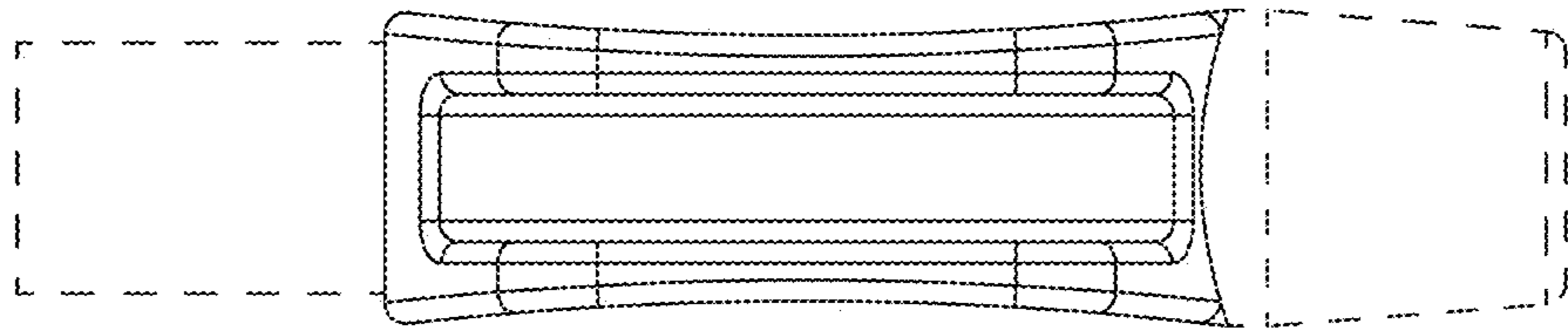

FIG. 2

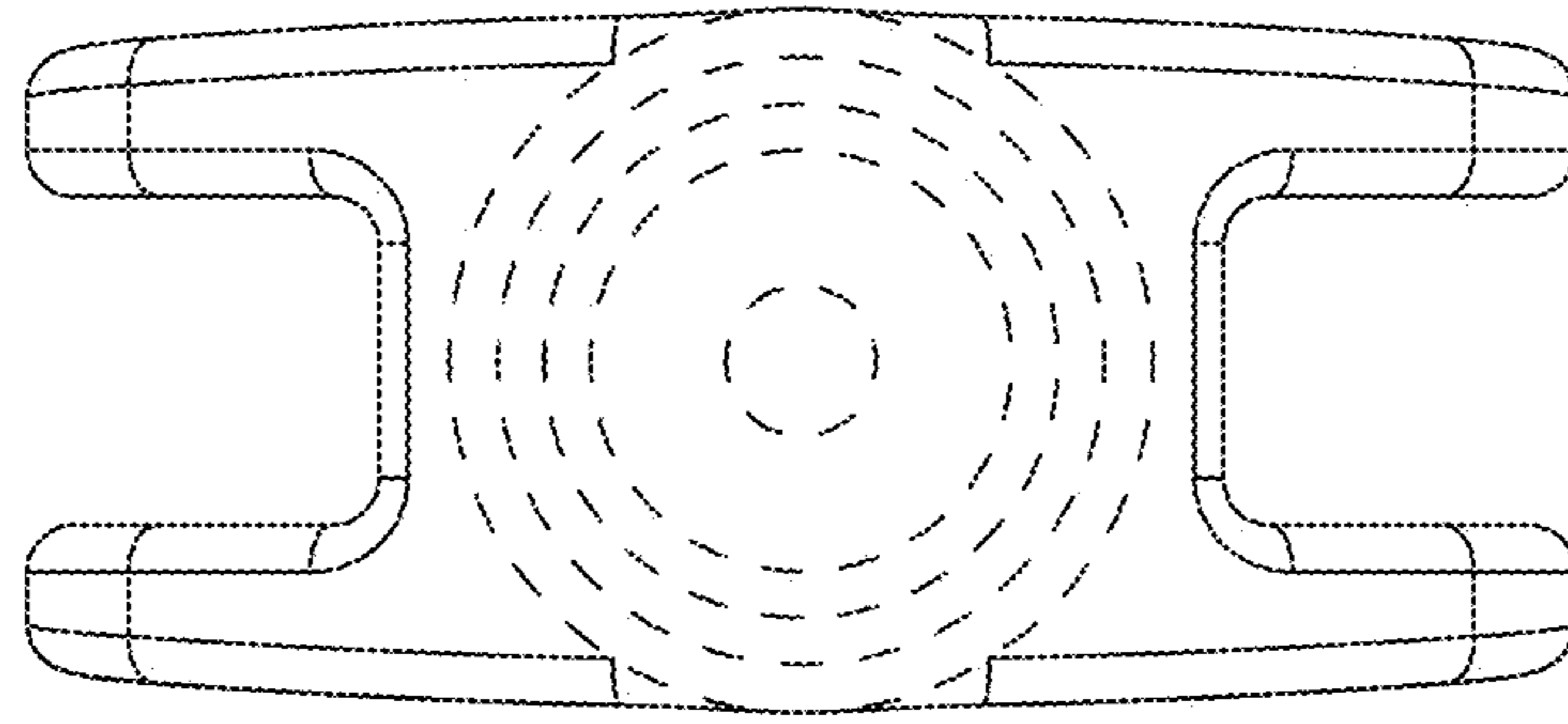

FIG. 3

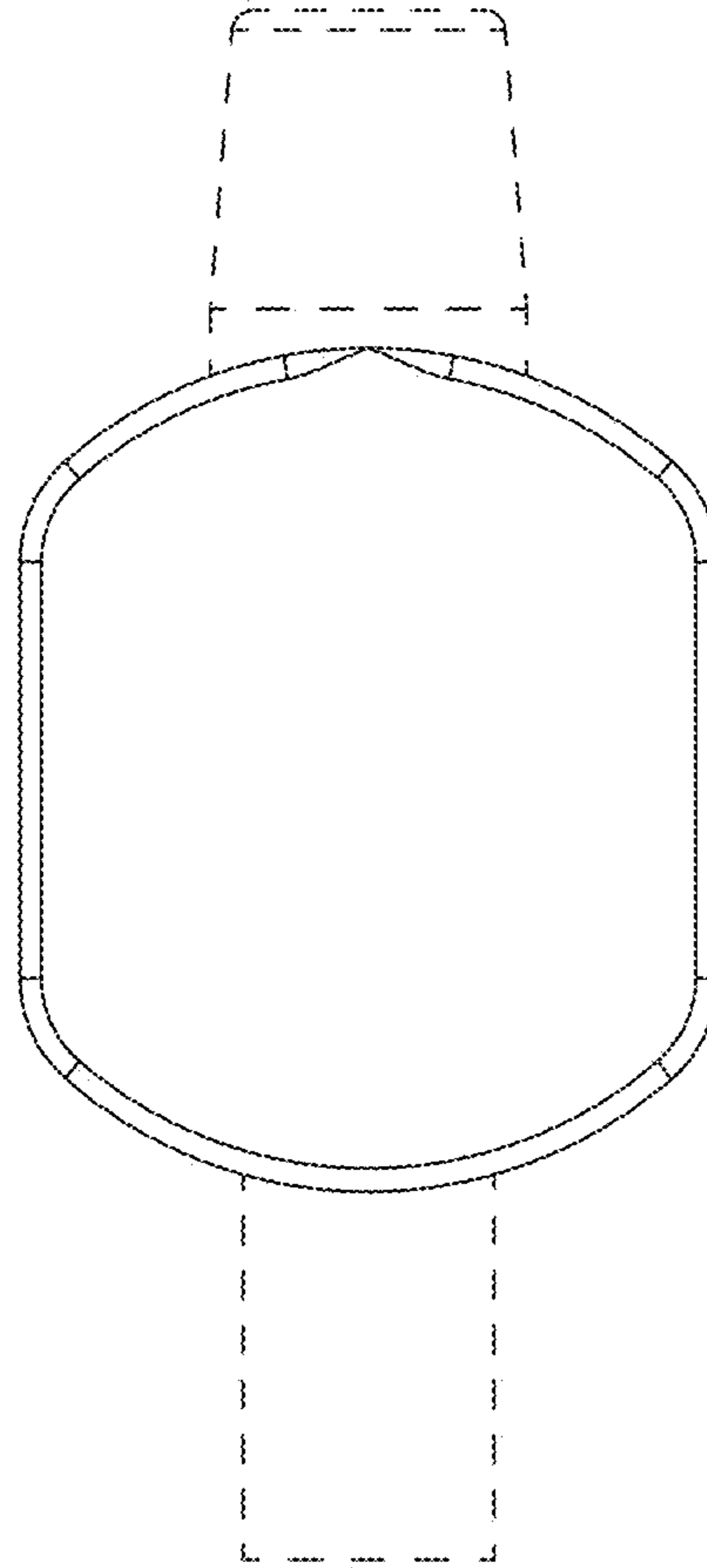

FIG. 4

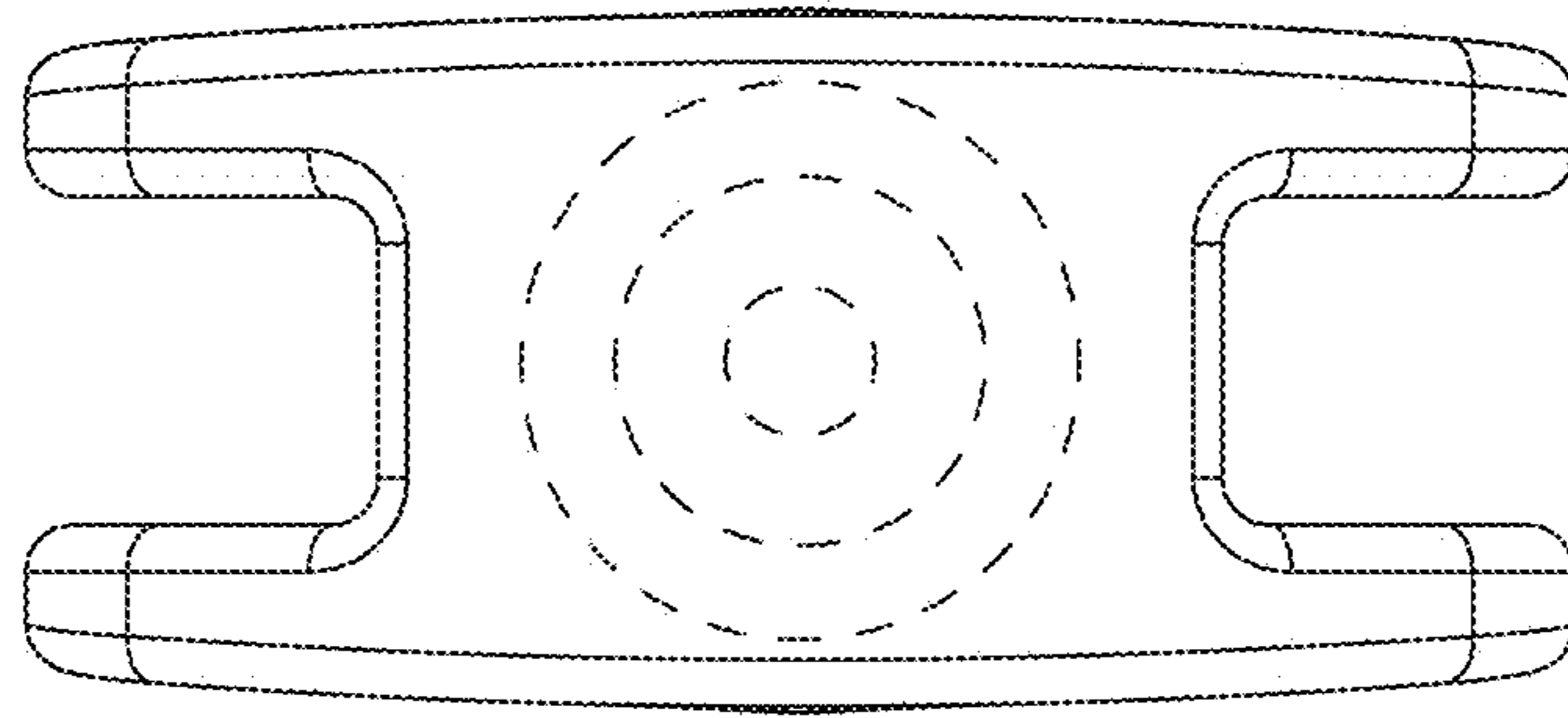

FIG. 5

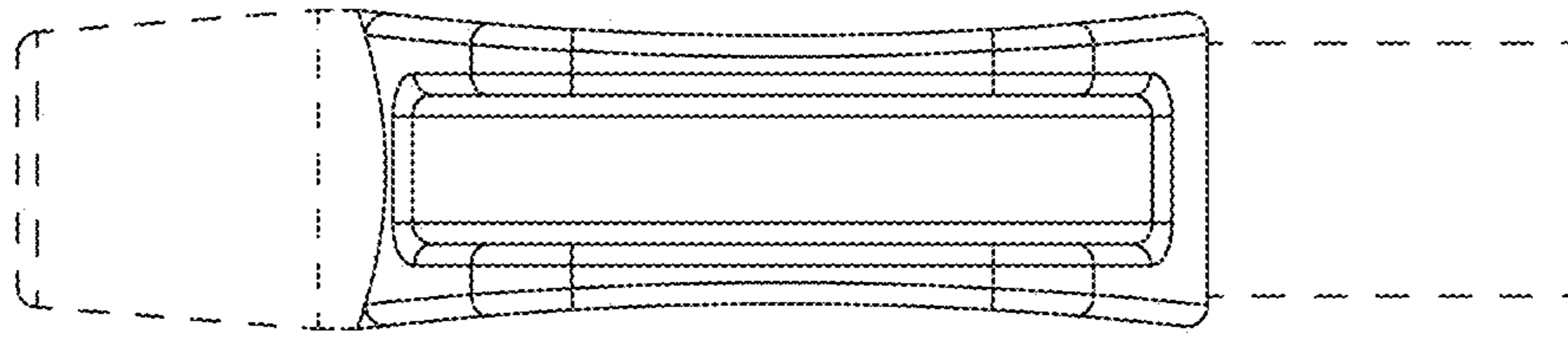

FIG. 6

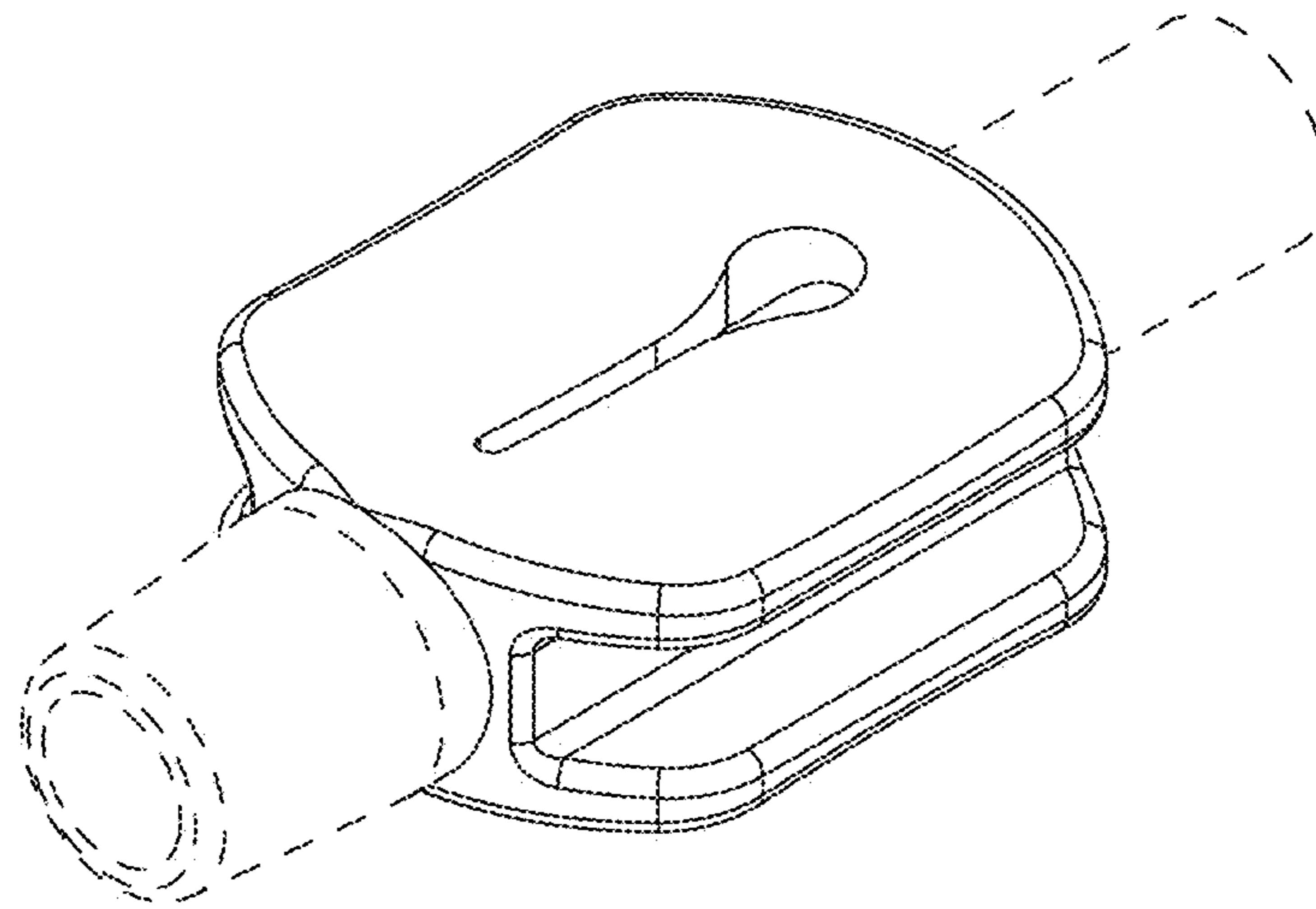

FIG. 7

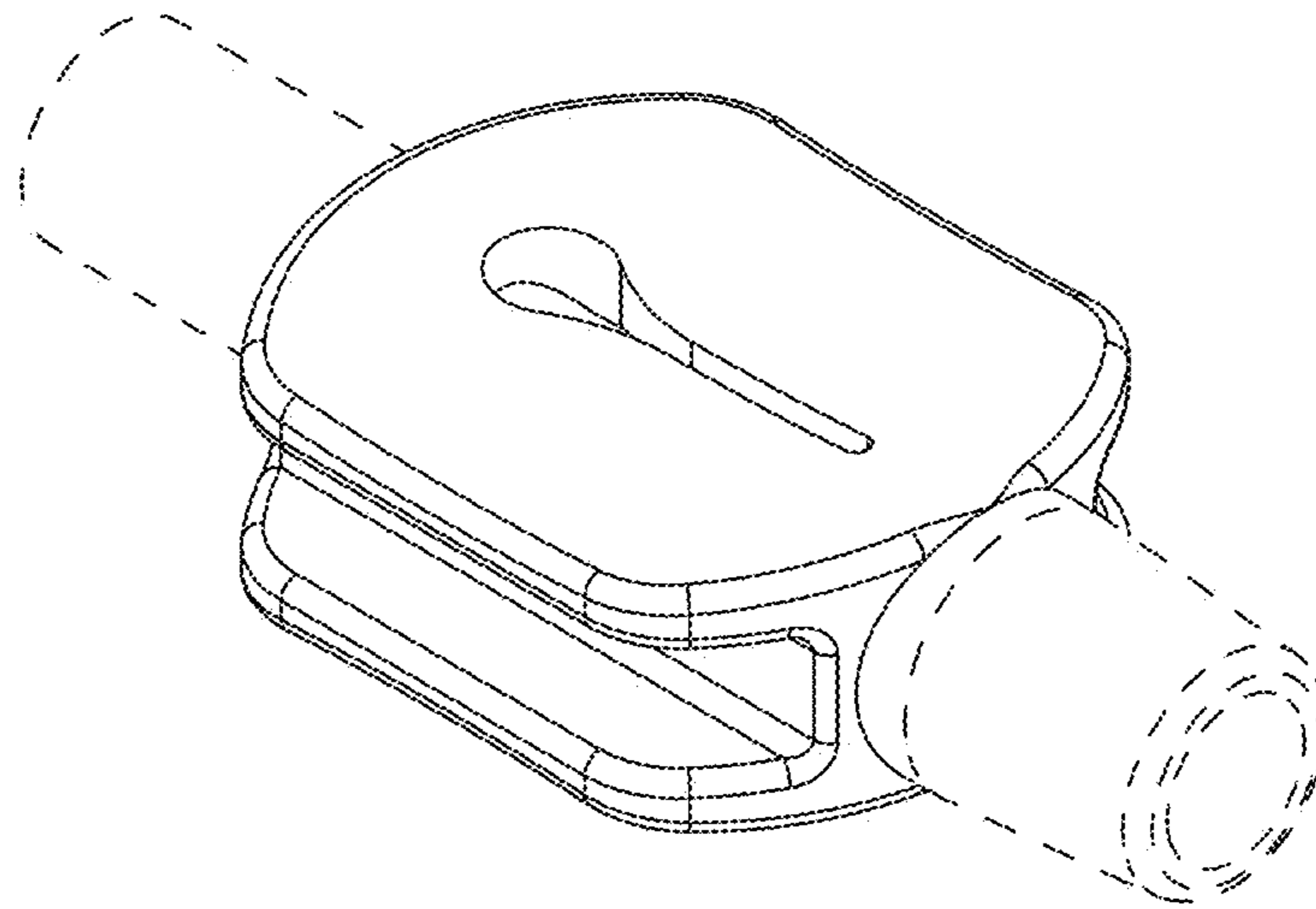

FIG. 8

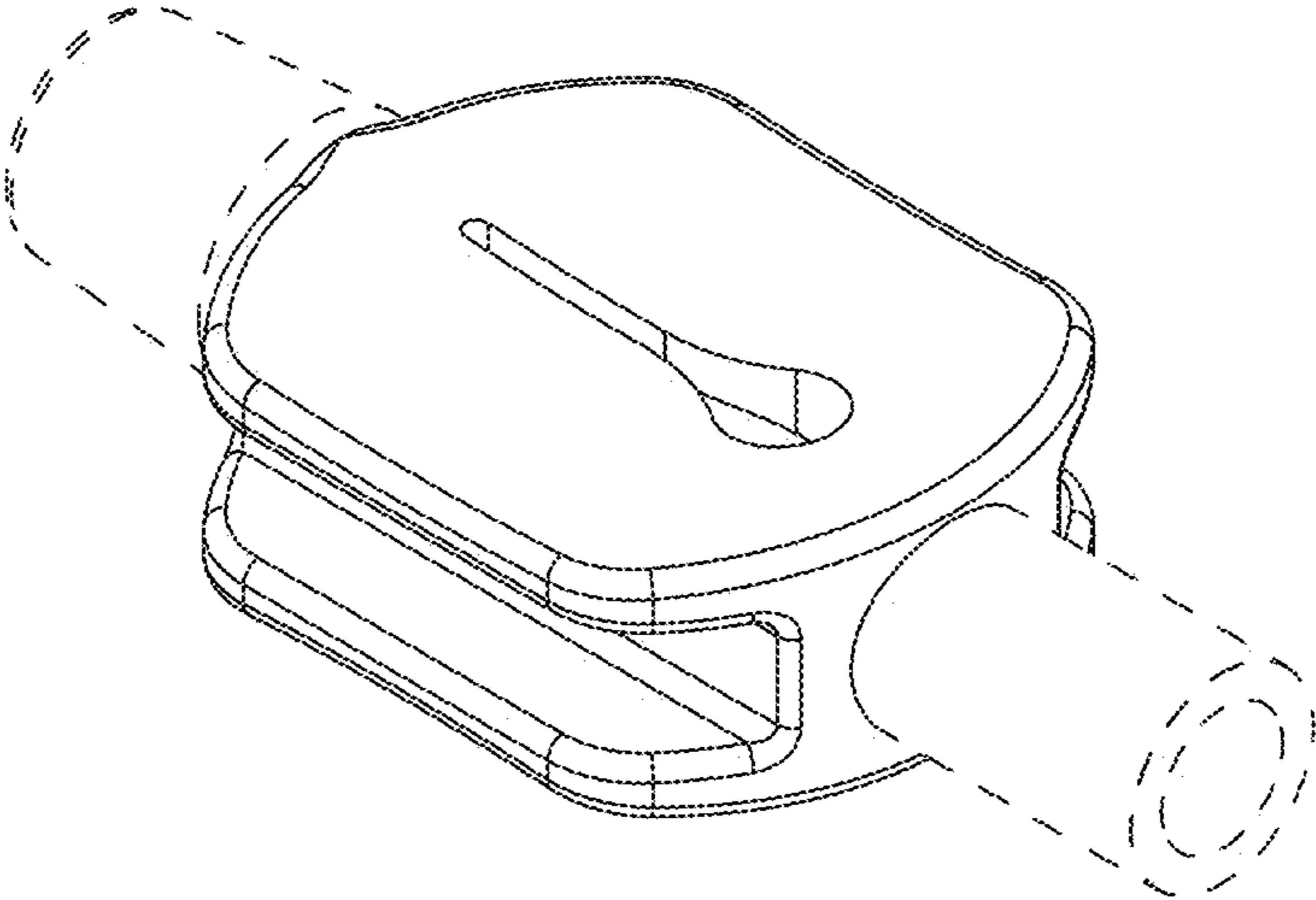

FIG. 9

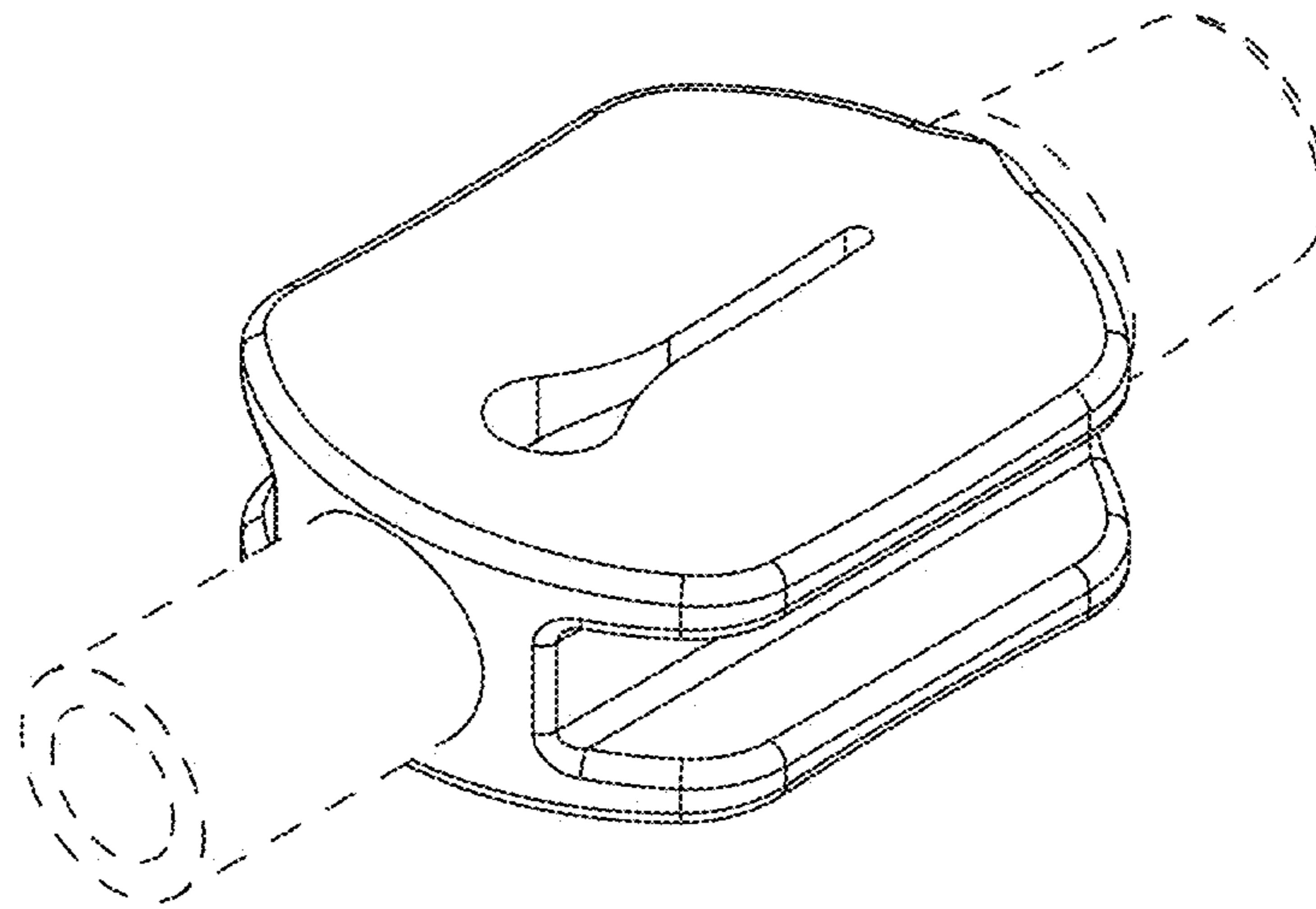

FIG. 10

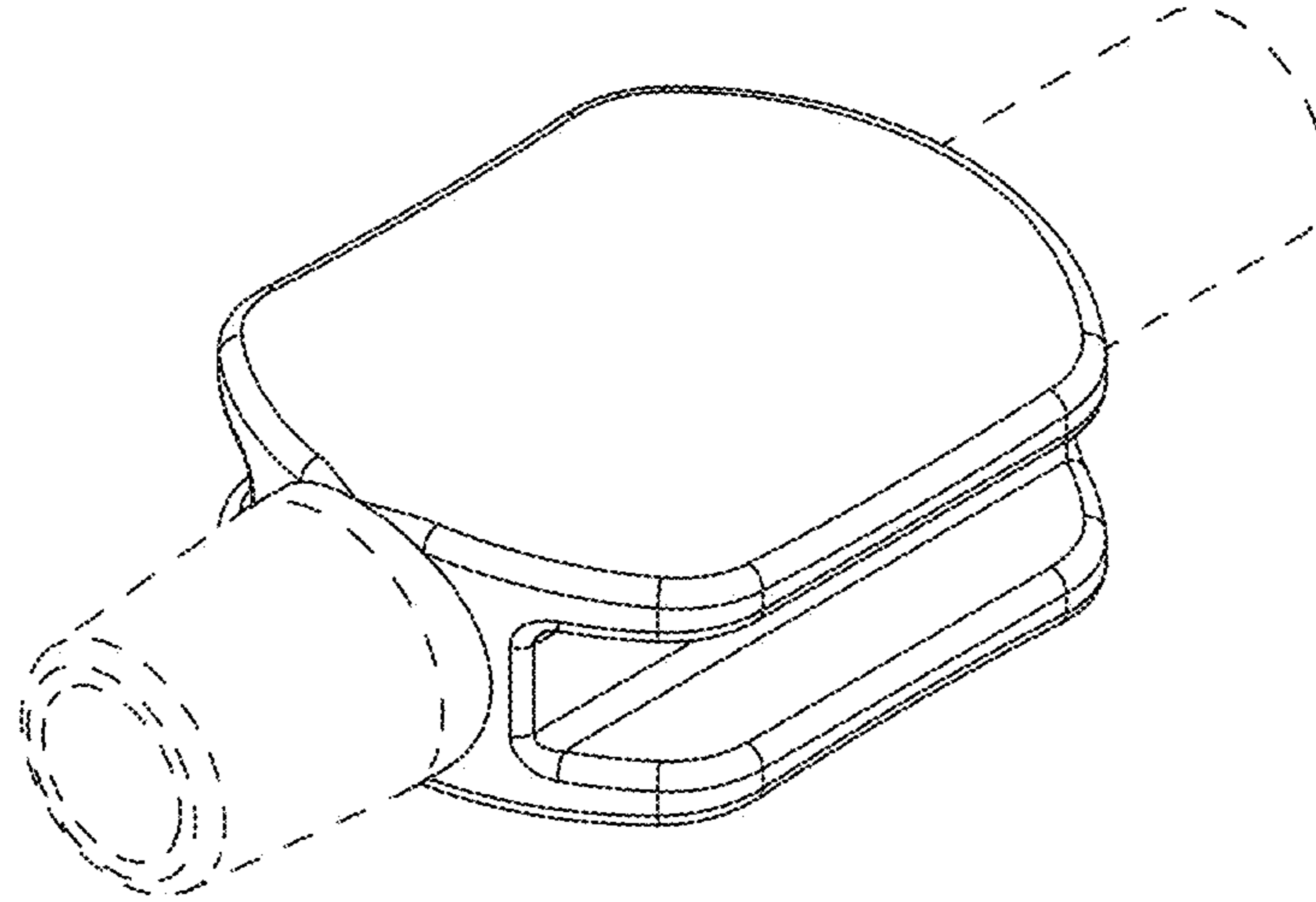

FIG. 11

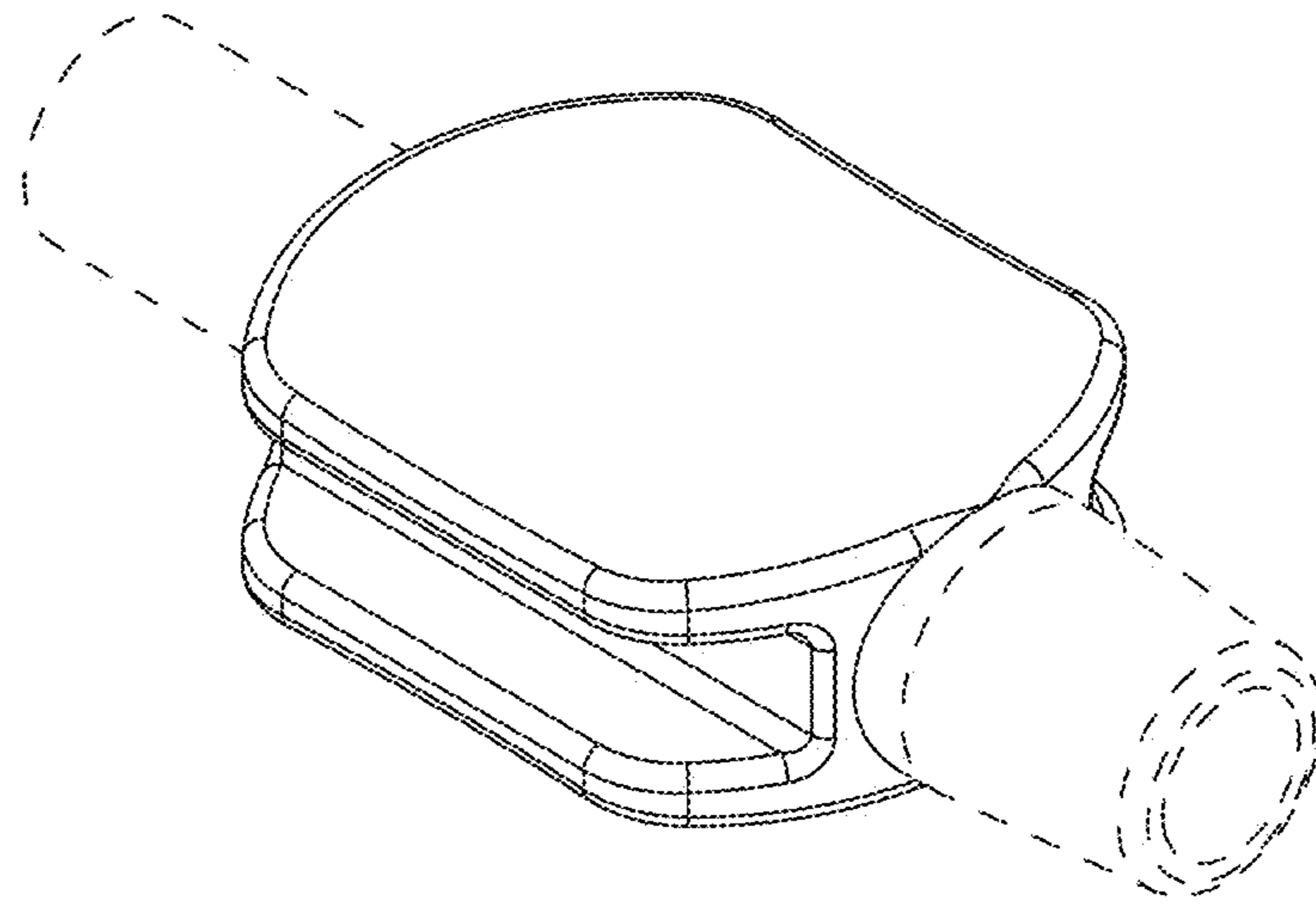

FIG. 12

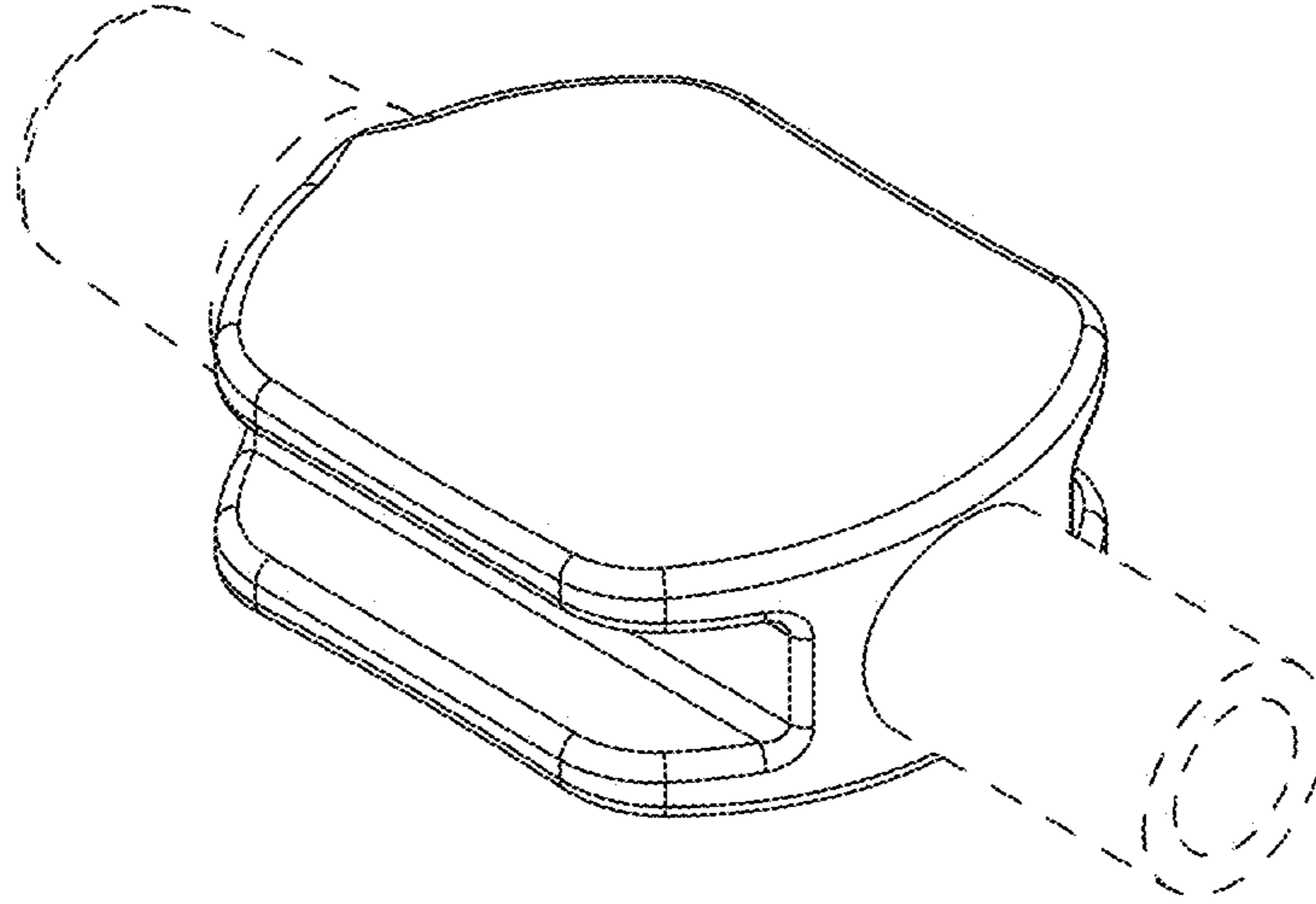

FIG. 13

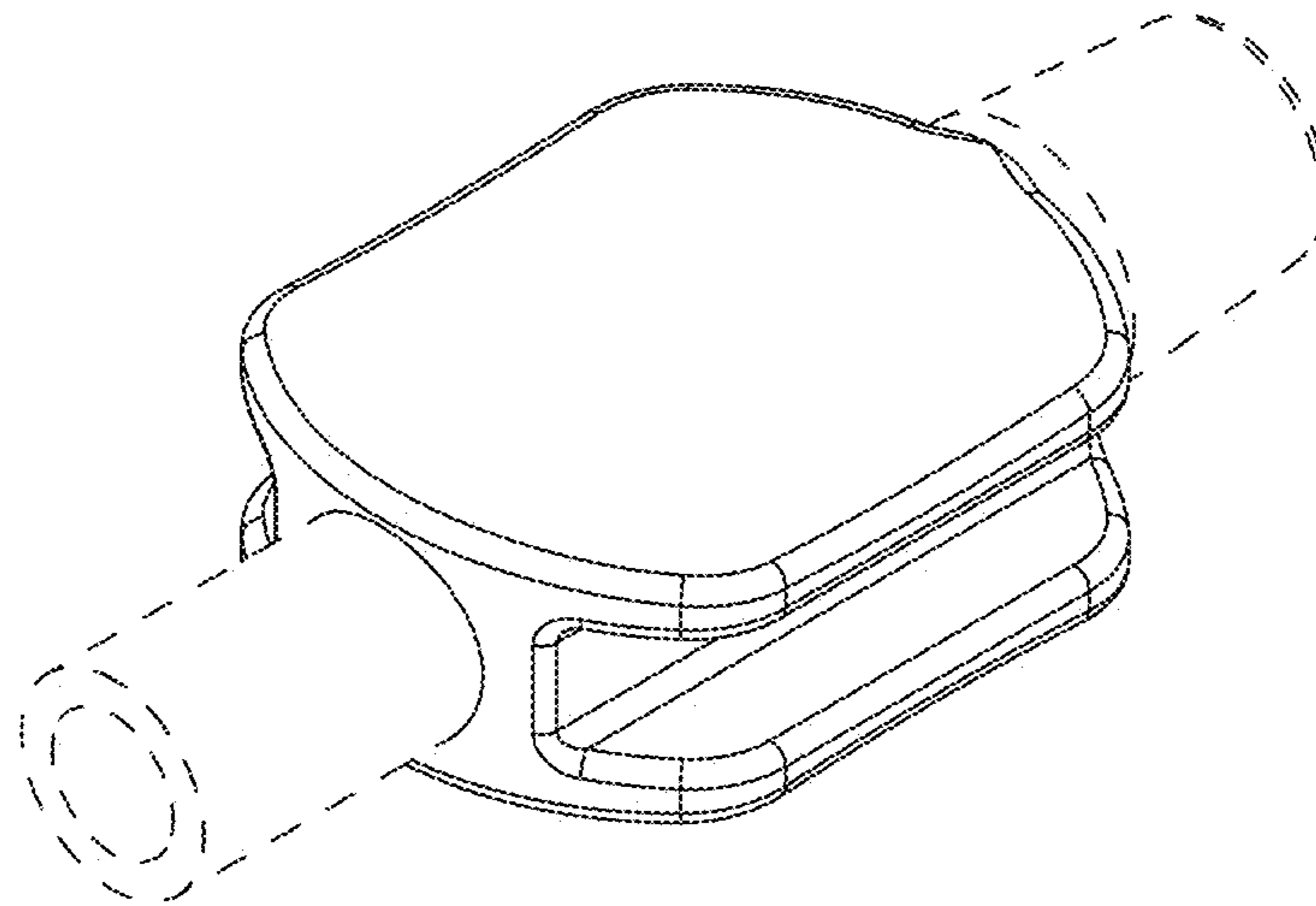

FIG. 14