



US00D978038S

(12) **United States Design Patent** (10) **Patent No.:** **US D978,038 S**
Porskrog et al. (45) **Date of Patent:** **** Feb. 14, 2023**

(54) **HYDRAULIC STEERING VALVE**

11,014,604 B2 * 5/2021 Pedersen B62D 3/14
 D937,159 S * 11/2021 Jumper D12/177
 D955,944 S * 6/2022 Topp D12/180

(71) Applicant: **Danfoss Power Solutions ApS**,
Nordborg (DK)

(72) Inventors: **Bendt Porskrog**, Nordborg (DK); **Rafal Slusarczyk**, Kobierzyce (PL)

(73) Assignee: **White Drive Motors and Steering SP. Z.O.O.**, Kobierzyce (PL)

(**) Term: **15 Years**

(21) Appl. No.: **29/717,193**

(22) Filed: **Dec. 16, 2019**

(30) **Foreign Application Priority Data**

Jun. 17, 2019 (EM) 006582623

(51) **LOC (14) Cl.** **12-16**

(52) **U.S. Cl.**
USPC **D12/177**

(58) **Field of Classification Search**
 USPC D12/174, 177, 180, 207–209, 400;
 D15/5, 7, 28, 149; D23/233, 262
 CPC B62D 3/14; B60T 8/1831; B60T 11/32;
 B60T 8/176; B60T 2270/10; B60T
 2270/12; B60T 8/1766; B60T 8/1769
 See application file for complete search history.

(56) **References Cited**

U.S. PATENT DOCUMENTS

D542,307 S * 5/2007 Stephenson D15/5
 D681,782 S * 5/2013 Bohm D23/233
 D681,784 S * 5/2013 Liljegren D23/262
 D803,896 S * 11/2017 Jilbert D15/28
 D839,803 S * 2/2019 Kanbargi D12/177
 D853,913 S * 7/2019 Sunaga D12/177
 D875,002 S * 2/2020 Chan D12/177
 10,862,382 B2 * 12/2020 Sorensen G01D 5/2073

OTHER PUBLICATIONS

“Steering units” Danfoss, posted date Mar. 27, 2018 [online], [retrieved on Aug. 26, 2022]. Retrieved from the Internet <URL: <https://www.danfoss.com/en-us/products/dps/steering/hydraulic-and-electrohydraulic-steering/hydraulic-steering/steering-units/>> (Year: 2018).*

“Hydraulic Steering Control Units” Costex., posted date Feb. 25, 2019 [online], [retrieved on Aug. 26, 2022]. Retrieved from the Internet <URL: <https://www.costex.com/hydraulic-steering-control-units/>> (Year: 2019).*

“Trail-Gear Orbital Steering Control Valve” Trail-Gear., posted date Jun. 20, 2019 [online], [retrieved on Aug. 26, 2022]. Retrieved from the Internet <URL: <https://trail-gear.com/orbital-steering-control-valve.html>> (Year: 2019).*

* cited by examiner

Primary Examiner — Darlington Ly

Assistant Examiner — Nasim Abdulaziz Ali

(74) *Attorney, Agent, or Firm* — McCormick, Paulding & Huber PLLC

(57) **CLAIM**

The ornamental design for a hydraulic steering unit, substantially as shown and described.

DESCRIPTION

FIG. 1 is a top, front, and right side perspective view of a hydraulic steering unit embodying our new design;
 FIG. 2 is a front elevation view thereof;
 FIG. 3 is a rear elevation view thereof;
 FIG. 4 is a top plan view thereof;
 FIG. 5 is a bottom plan view thereof;
 FIG. 6 is a left side elevation view thereof; and,
 FIG. 7 is a right side elevation view thereof.

1 Claim, 7 Drawing Sheets

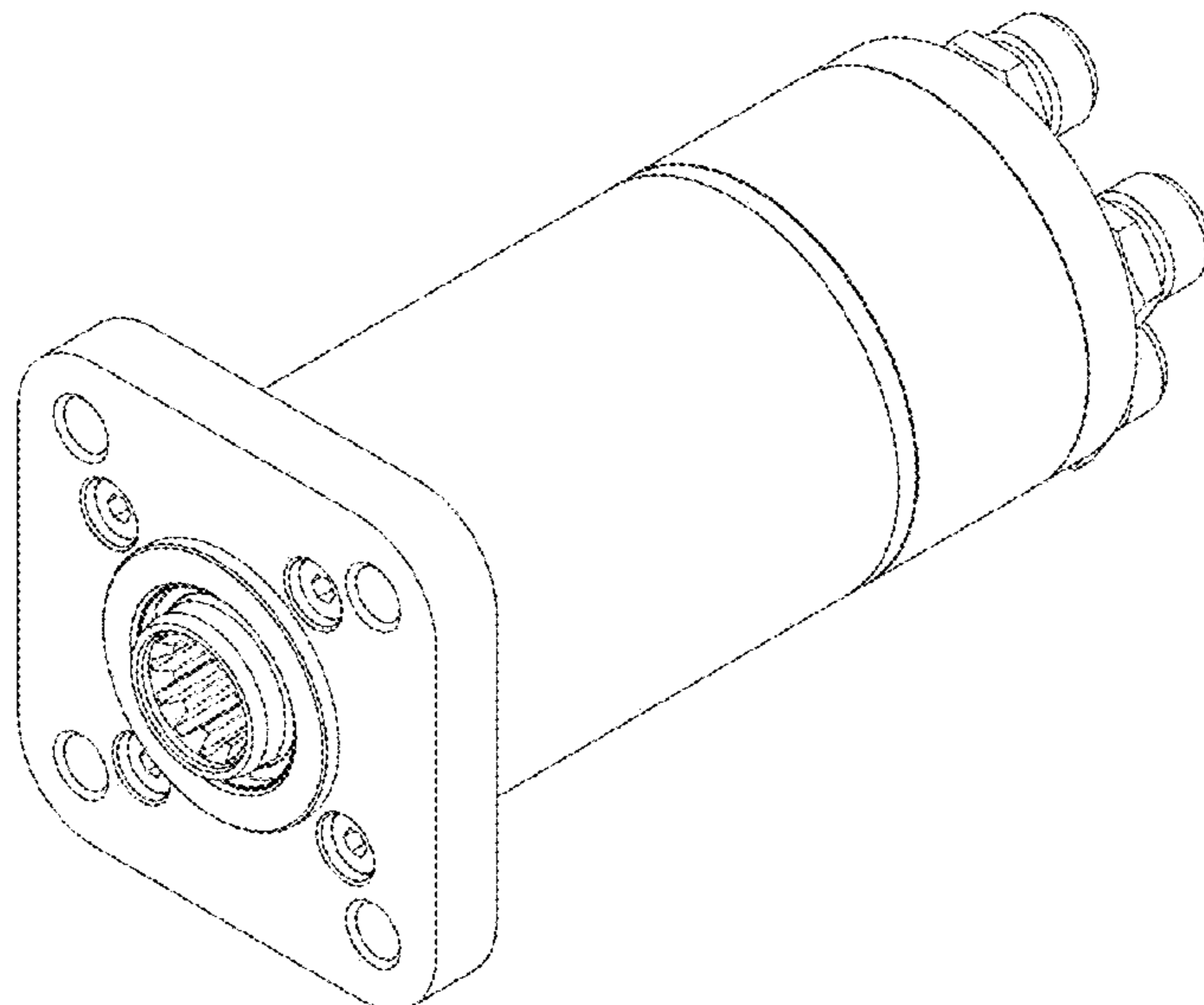

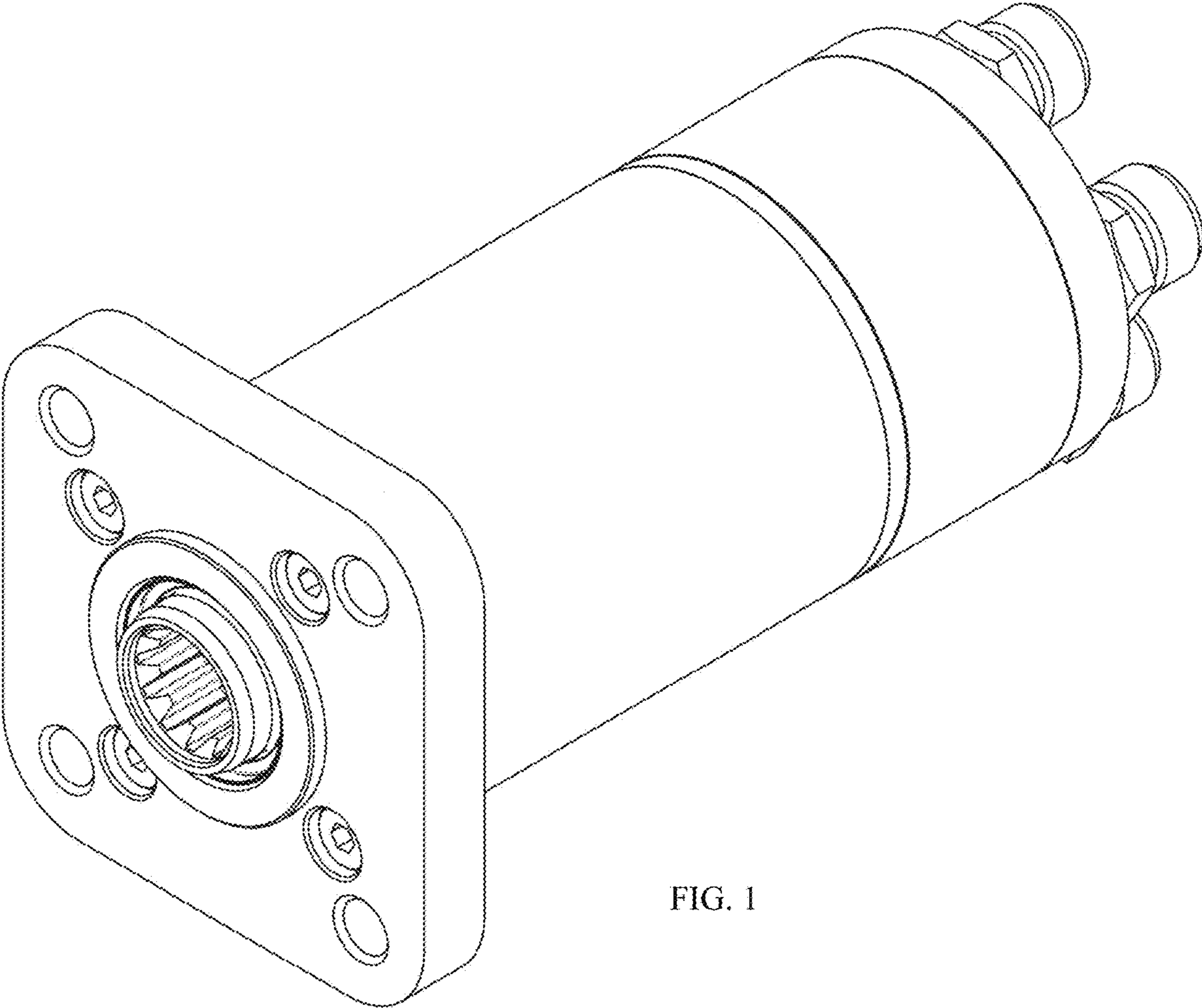

FIG. 1

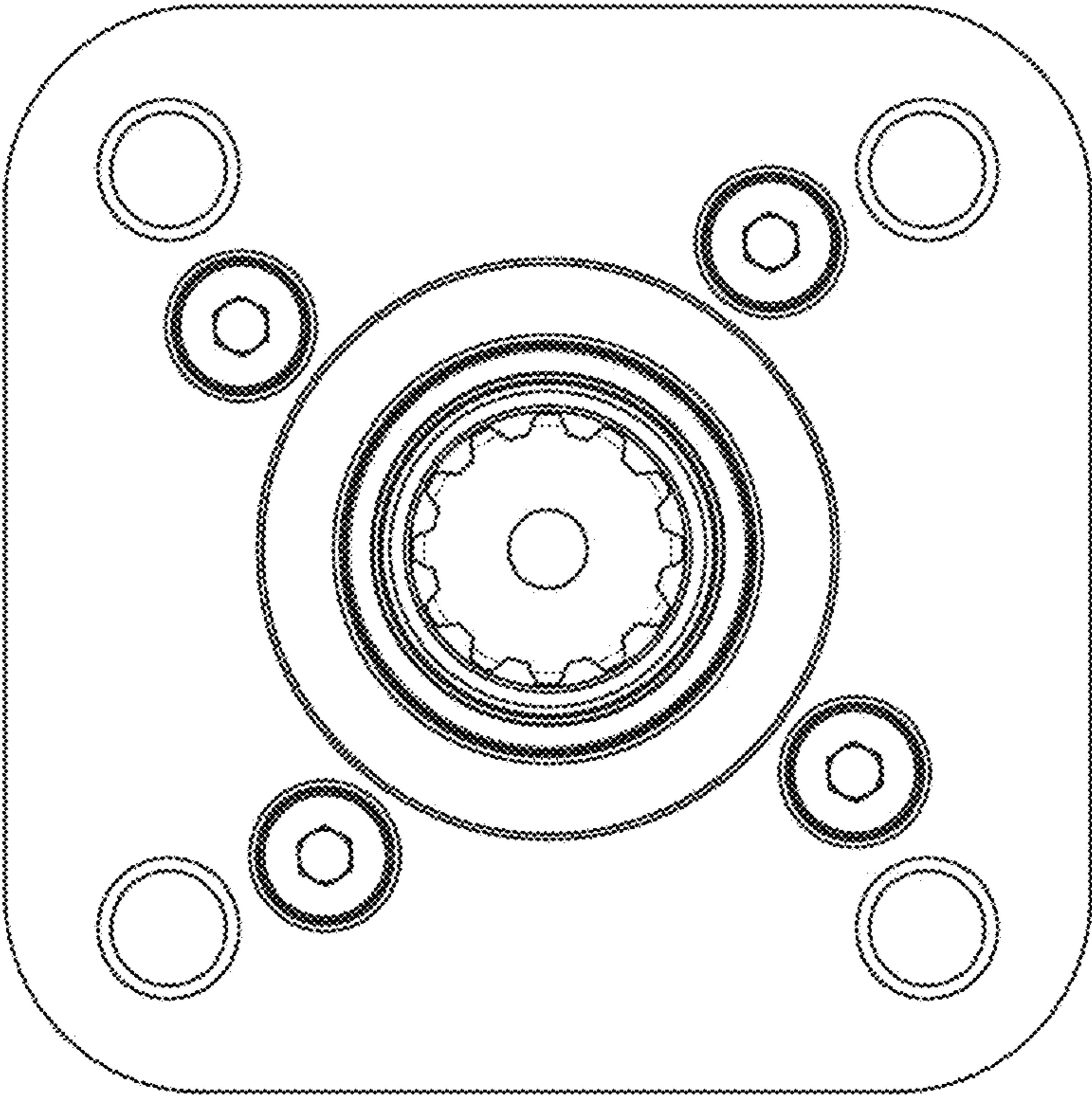

FIG. 2

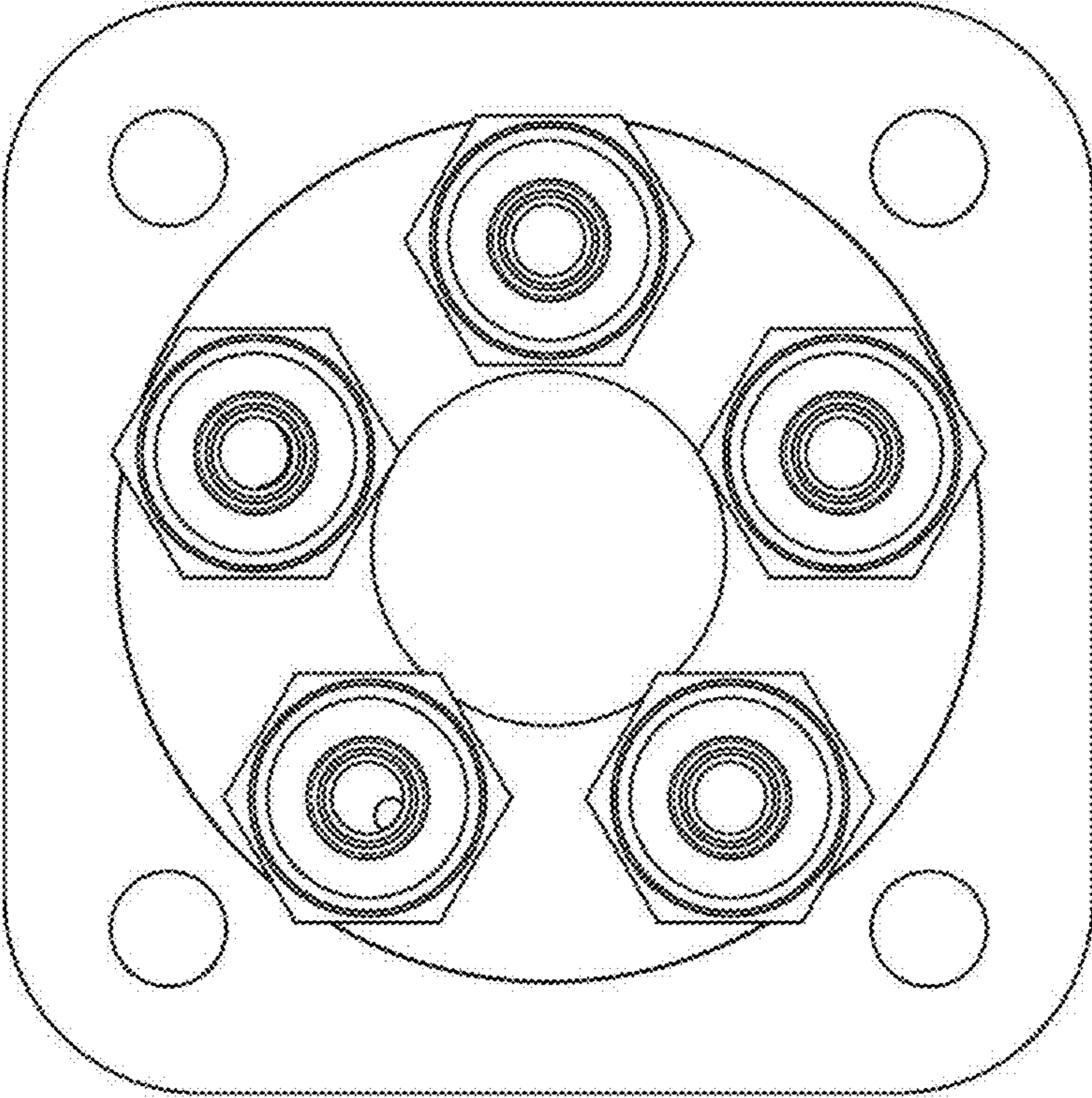

FIG. 3

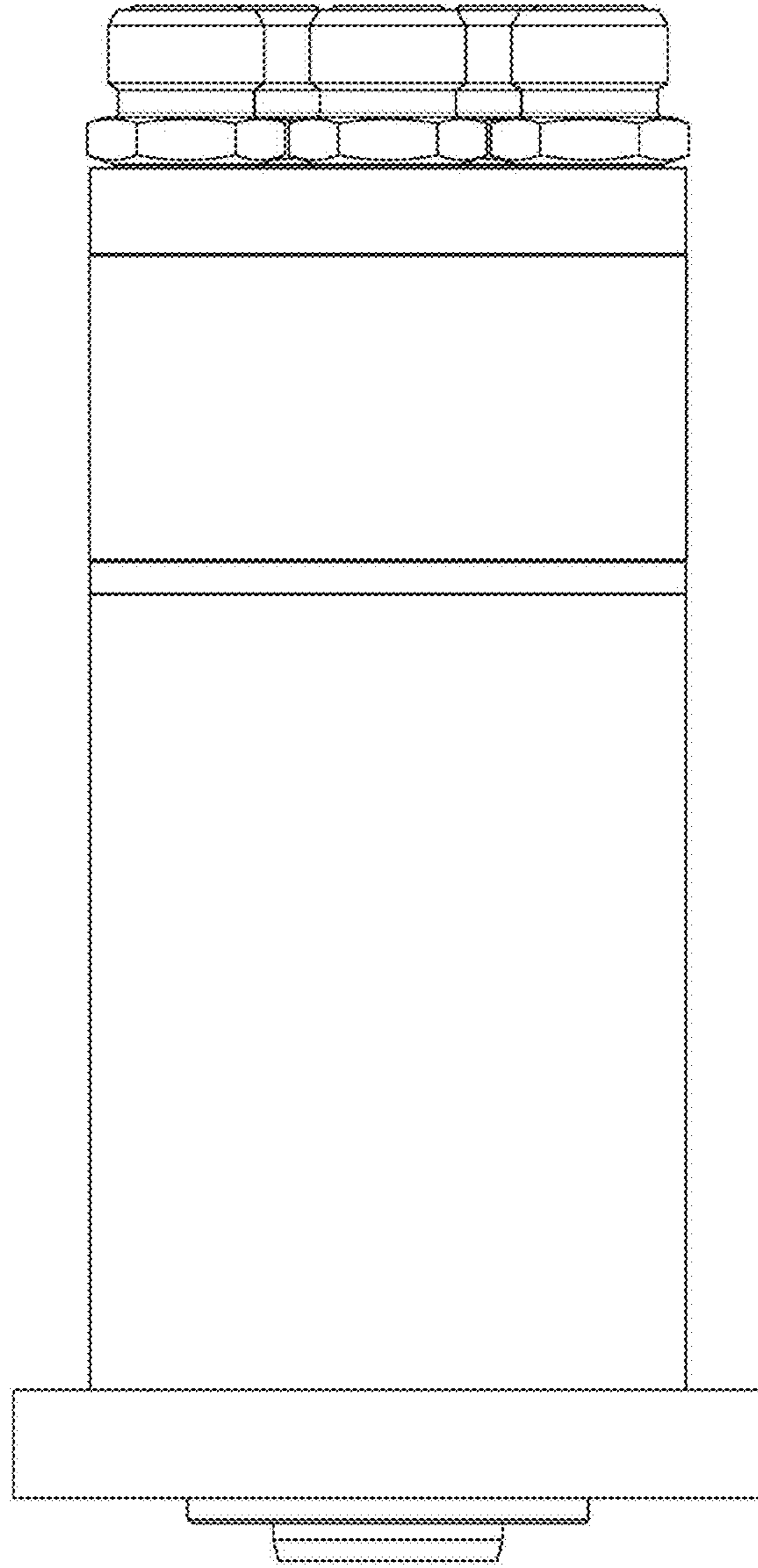

FIG. 4

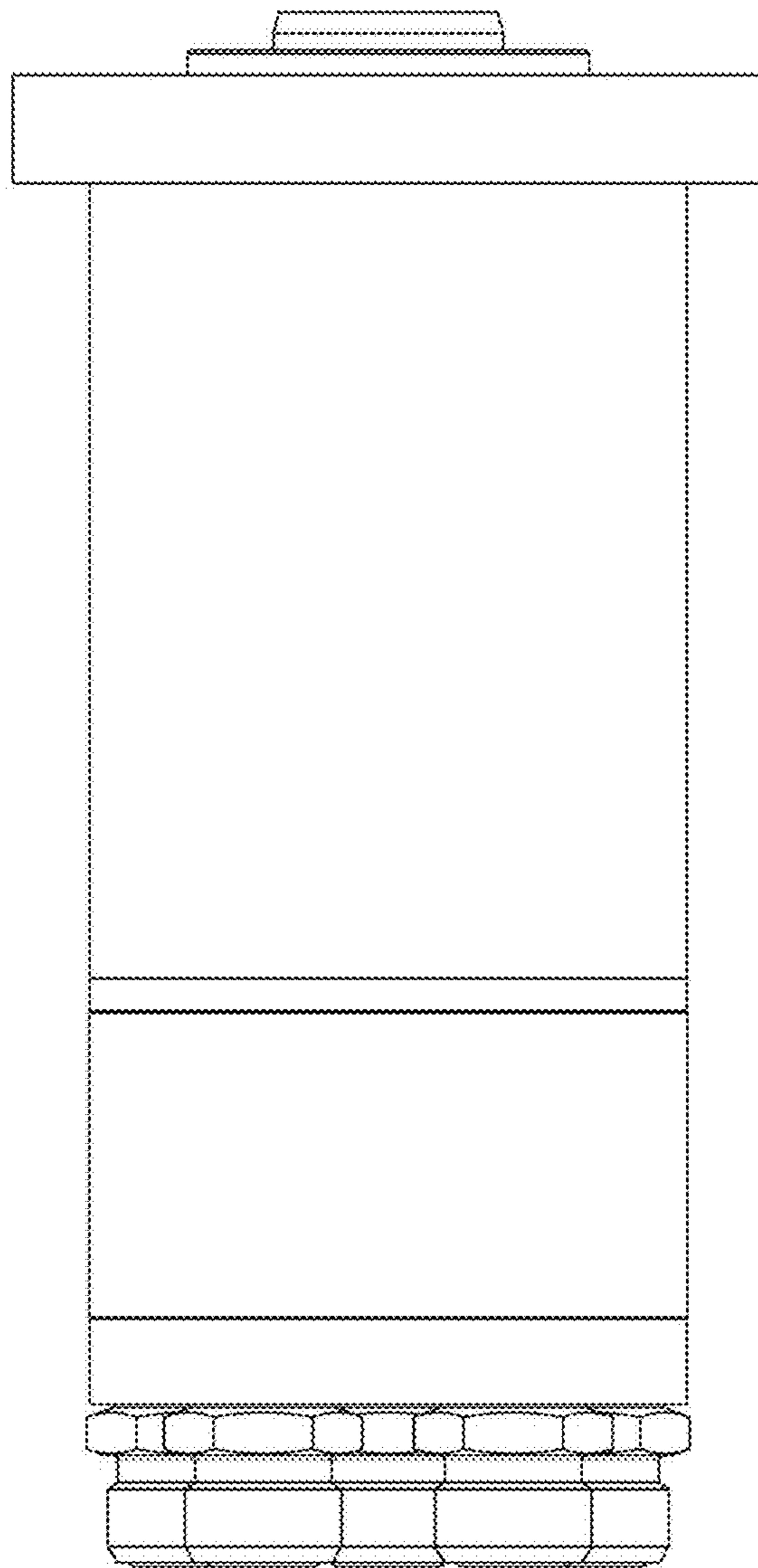

FIG. 5

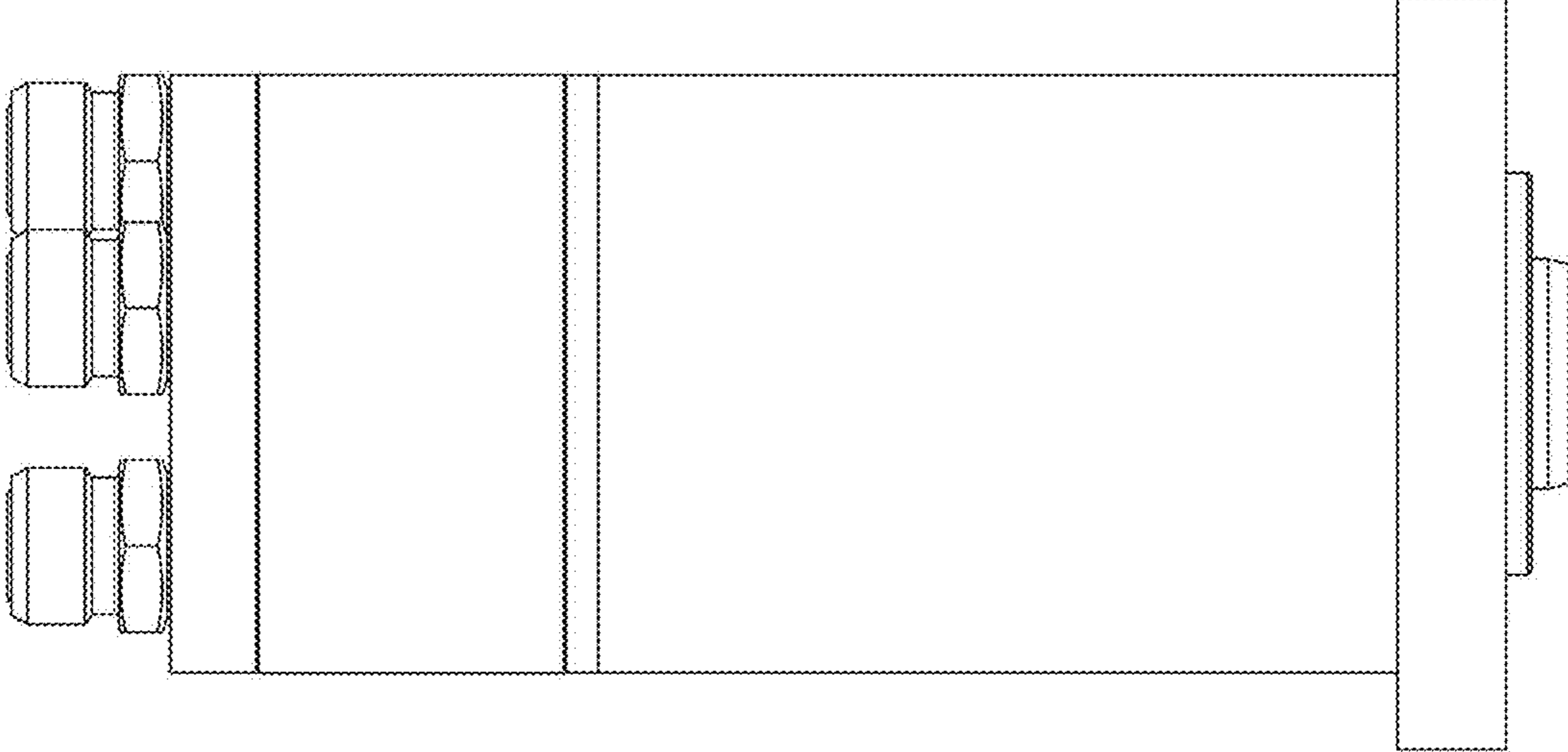

FIG. 6

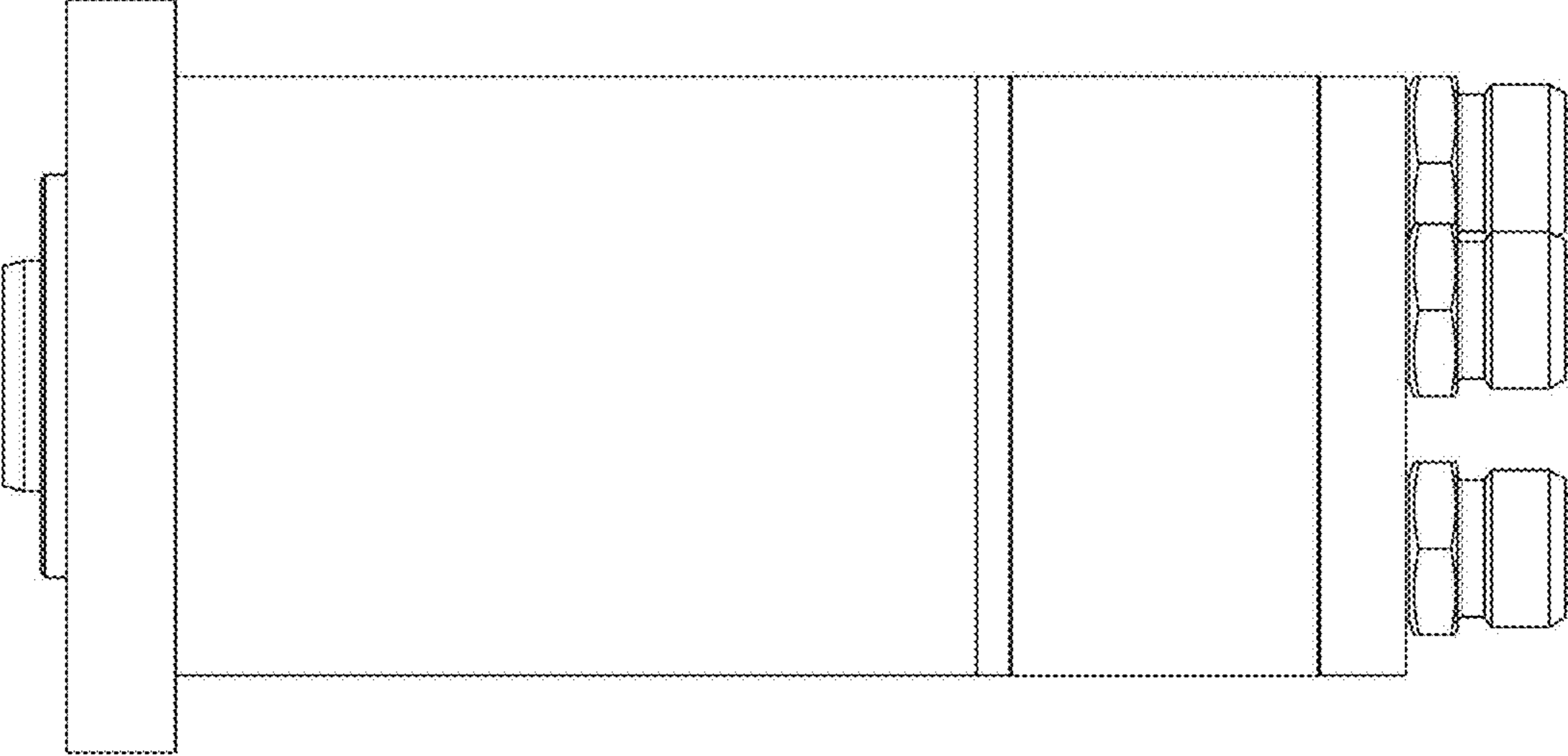

FIG. 7