



US00D977464S

(12) **United States Design Patent** (10) **Patent No.:** **US D977,464 S**  
**Hu** (45) **Date of Patent:** **\*\* Feb. 7, 2023**

(54) **ULTRA-WIDEBAND HORN ANTENNA**

FOREIGN PATENT DOCUMENTS

(71) Applicant: **Nan Hu**, Irvine, CA (US)

CN 303816245 \* 8/2016  
CN 304122823 \* 5/2017

(72) Inventor: **Nan Hu**, Irvine, CA (US)

(Continued)

(\*\*) Term: **15 Years**

OTHER PUBLICATIONS

(21) Appl. No.: **29/763,148**

Pasternack, "Broadband Gain Horn Antenna . . ." available at pasternack.com, date published 2016, site visited Aug. 23, 2022, Available at URL: <https://bit.ly/3R3wffC> (Year: 2016).\*

(22) Filed: **Dec. 21, 2020**

(Continued)

(51) **LOC (14) Cl.** ..... **14-03**

(52) **U.S. Cl.**

USPC ..... **D14/230**

(58) **Field of Classification Search**

USPC ..... D14/230, 232-239, 343; D13/173, 182,  
D13/184, 199, 101, 117, 18, 154, 155  
CPC .. G01S 13/4409; G01S 13/4481; H01P 1/161;  
H01Q 13/0208; H01Q 13/10; H01Q  
13/00; H01Q 13/02; H01Q 13/0241;  
H01Q 19/13; H01Q 3/08

See application file for complete search history.

*Primary Examiner* — Daniel J Domino

*Assistant Examiner* — Samina Vieth

(74) *Attorney, Agent, or Firm* — Jianmin Zhou; Law  
Offices of James Zhou

(57) **CLAIM**

The ornamental design for an ultra-wideband horn antenna,  
as shown and described.

**DESCRIPTION**

FIG. 1 is a perspective view of an ultra-wideband horn antenna design showing my new design.

FIG. 2 is another perspective view of an ultra-wideband horn antenna.

FIG. 3 is a front view of an ultra-wideband horn antenna.

FIG. 4 is a rear view of an ultra-wideband horn antenna.

FIG. 5 is a right side view of an ultra-wideband horn antenna.

FIG. 6 is a left side view of an ultra-wideband horn antenna.

FIG. 7 is a top view of an ultra-wideband horn antenna; and,

FIG. 8 is a bottom view of an ultra-wideband horn antenna.

Any shading and cross-hatching are not features of the design but are utilized to illustrate the surface contours of the ultra-wideband horn antenna design in the drawings.

The broken lines depict portions of the ultra-wideband horn antenna that form no part of the claimed design.

(56) **References Cited**

U.S. PATENT DOCUMENTS

2,012,538 A \* 8/1935 Krohn ..... G10K 11/08  
181/178  
2,825,060 A \* 2/1958 Ruze ..... H01Q 13/0258  
343/756  
2,963,701 A \* 12/1960 Hagaman ..... H01Q 3/34  
342/368  
2,979,679 A \* 4/1961 Ellis ..... H01P 1/161  
333/253  
3,162,828 A \* 12/1964 Schmidt ..... H01P 1/161  
343/756  
3,267,475 A \* 8/1966 Howard ..... G01S 13/4454  
343/858

(Continued)

**1 Claim, 8 Drawing Sheets**

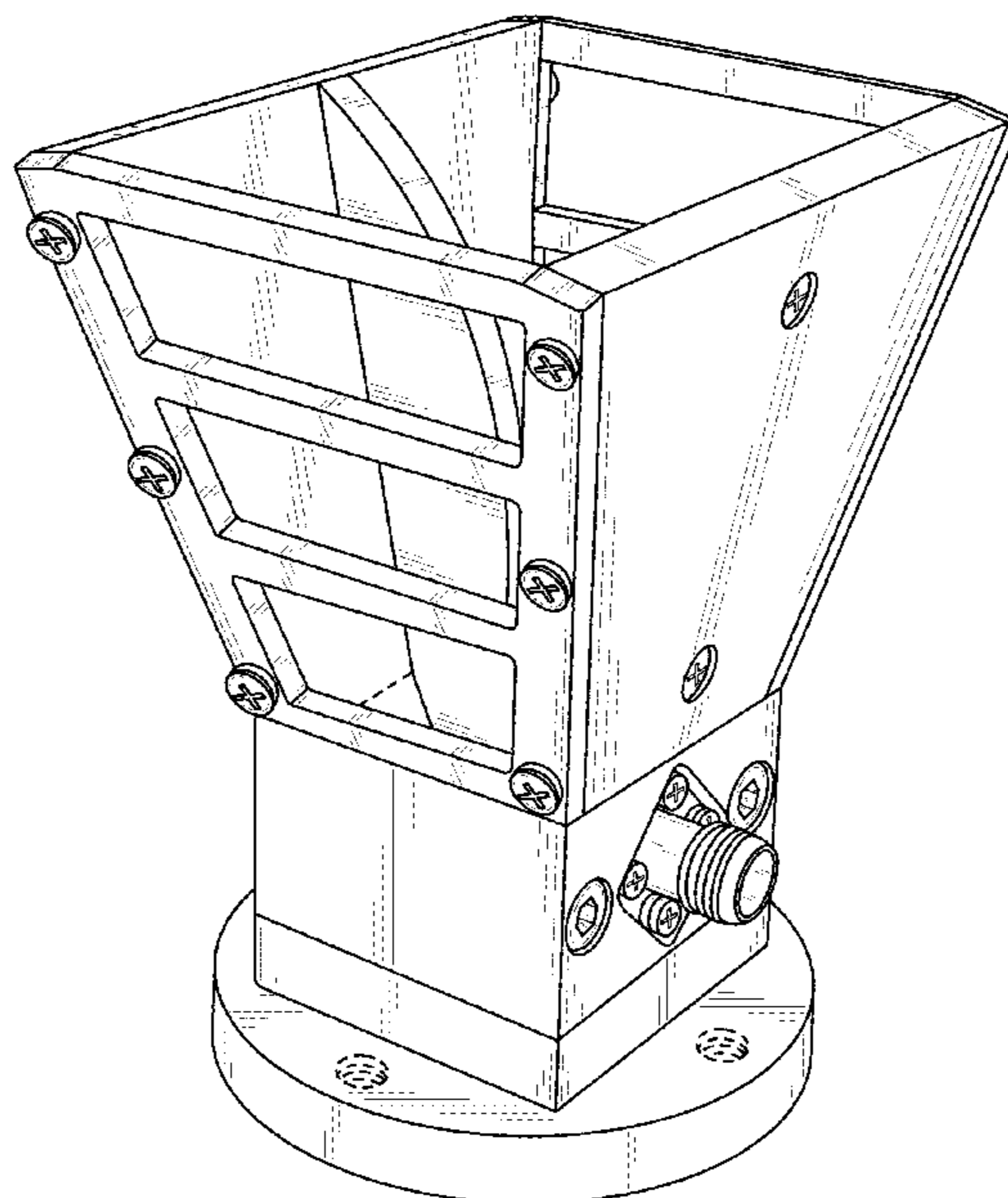

(56)

**References Cited**

U.S. PATENT DOCUMENTS

4,533,919 A \* 8/1985 Dragone ..... H01Q 13/0208  
 343/786  
 D337,591 S \* 7/1993 Buhyoff ..... D14/239  
 D345,145 S \* 3/1994 Fogg ..... D13/184  
 5,329,285 A \* 7/1994 McCandless ..... G01S 13/4409  
 342/153  
 D363,464 S \* 10/1995 Fukasawa ..... D13/182  
 D503,155 S \* 3/2005 Noji ..... D13/153  
 6,995,728 B2 \* 2/2006 Rodriguez ..... H01Q 13/0275  
 343/786  
 7,969,376 B2 \* 6/2011 Steghafner ..... H01Q 13/0275  
 343/773  
 8,248,321 B2 \* 8/2012 Anderson ..... H01Q 13/025  
 343/786  
 D869,447 S \* 12/2019 Hu ..... D14/230  
 11,031,692 B1 \* 6/2021 Hu ..... H01Q 13/0275  
 2003/0210197 A1 \* 11/2003 Cencich ..... H01Q 13/0241  
 343/786  
 2005/0017915 A1 \* 1/2005 Brown ..... H01Q 1/364  
 343/786  
 2005/0078044 A1 \* 4/2005 Rodriguez ..... H01Q 13/0275  
 343/786  
 2009/0079649 A1 \* 3/2009 Steghafner ..... H01Q 13/0275  
 343/786

2016/0020519 A1 \* 1/2016 Park ..... H01Q 21/0037  
 343/756  
 2016/0164189 A1 \* 6/2016 Jafarlou ..... H01Q 13/02  
 29/601  
 2021/0255227 A1 \* 8/2021 Hu ..... G01R 29/0878  
 2021/0305708 A1 \* 9/2021 Hu ..... H01Q 13/025

FOREIGN PATENT DOCUMENTS

CN 306217152 \* 12/2020  
 CN 30169760 \* 3/2022  
 CN 307256057 \* 4/2022

OTHER PUBLICATIONS

Aaronia, "PowerLOG 40400 Microwave Horn Antenna . . ." available at distek.ro, date published Aug. 3, 2016, site visited Aug. 23, 2022, Available at URL: <http://www.distek.ro/en/Product/AARONIA-PowerLOG-40400-Microwave-Horn-Antenna-4GHz..40GHz-3511> (Year: 2016).\*

RFEcho, "Broadband Dual Ridged Horn Antenna," available at rfecho.com, date published 2017, site visited Aug. 23, 2022, Available at URL: <https://www.rfecho.com/product/10-5-dbi-gain-1-ghz-to-18-ghz-broadband-horn-antenna/> (Year: 2017).\*

\* cited by examiner

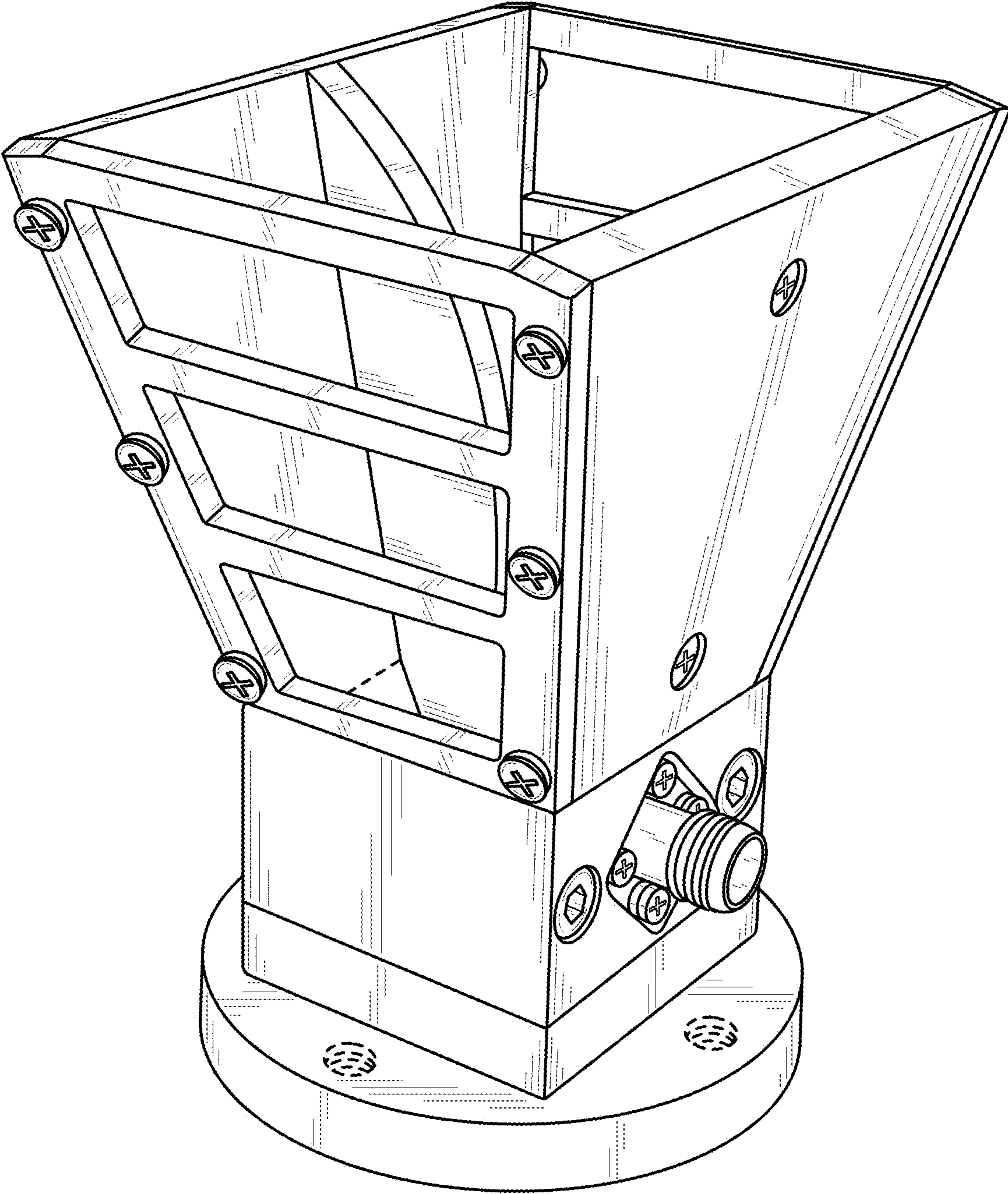

FIG. 1

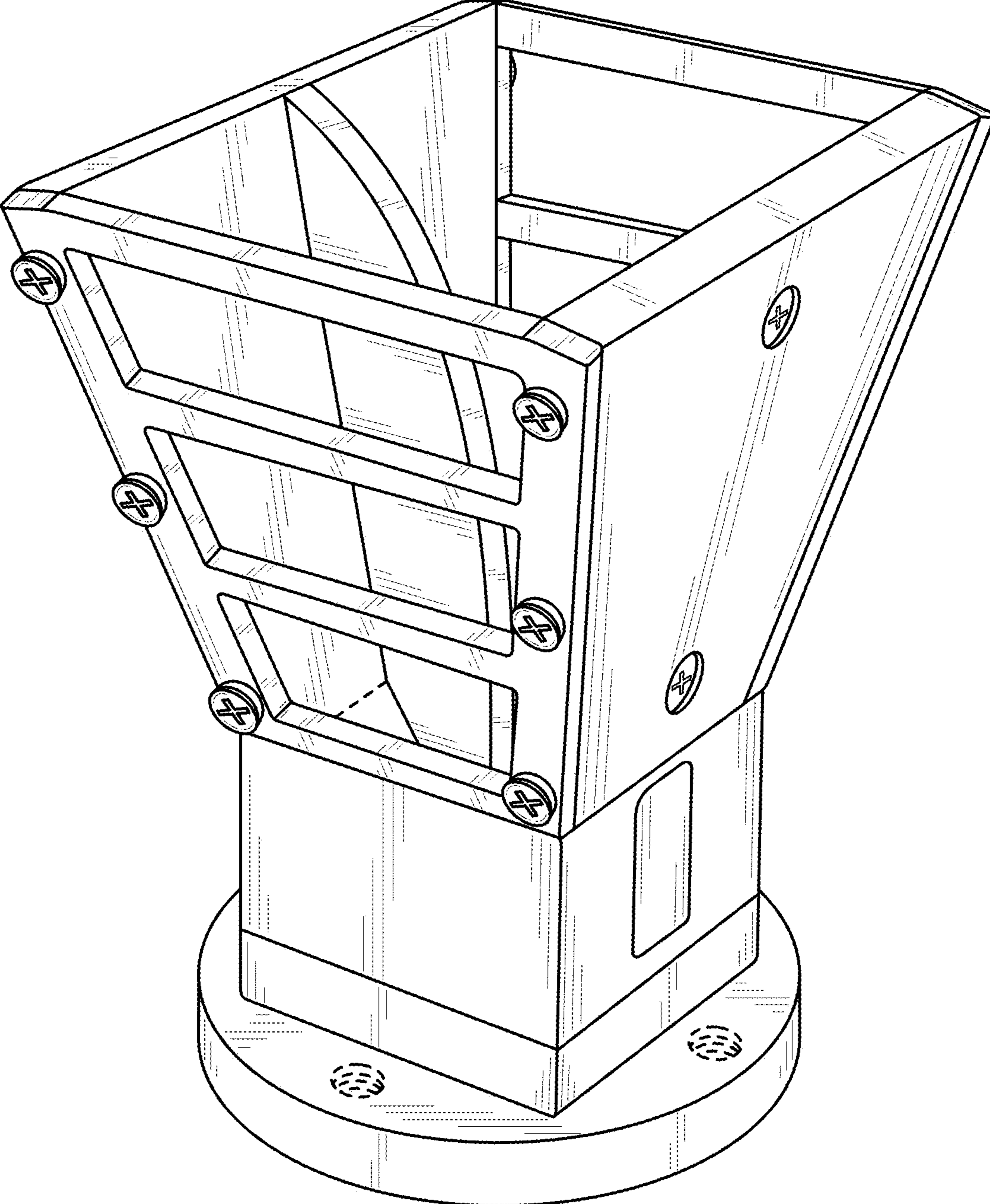

FIG. 2

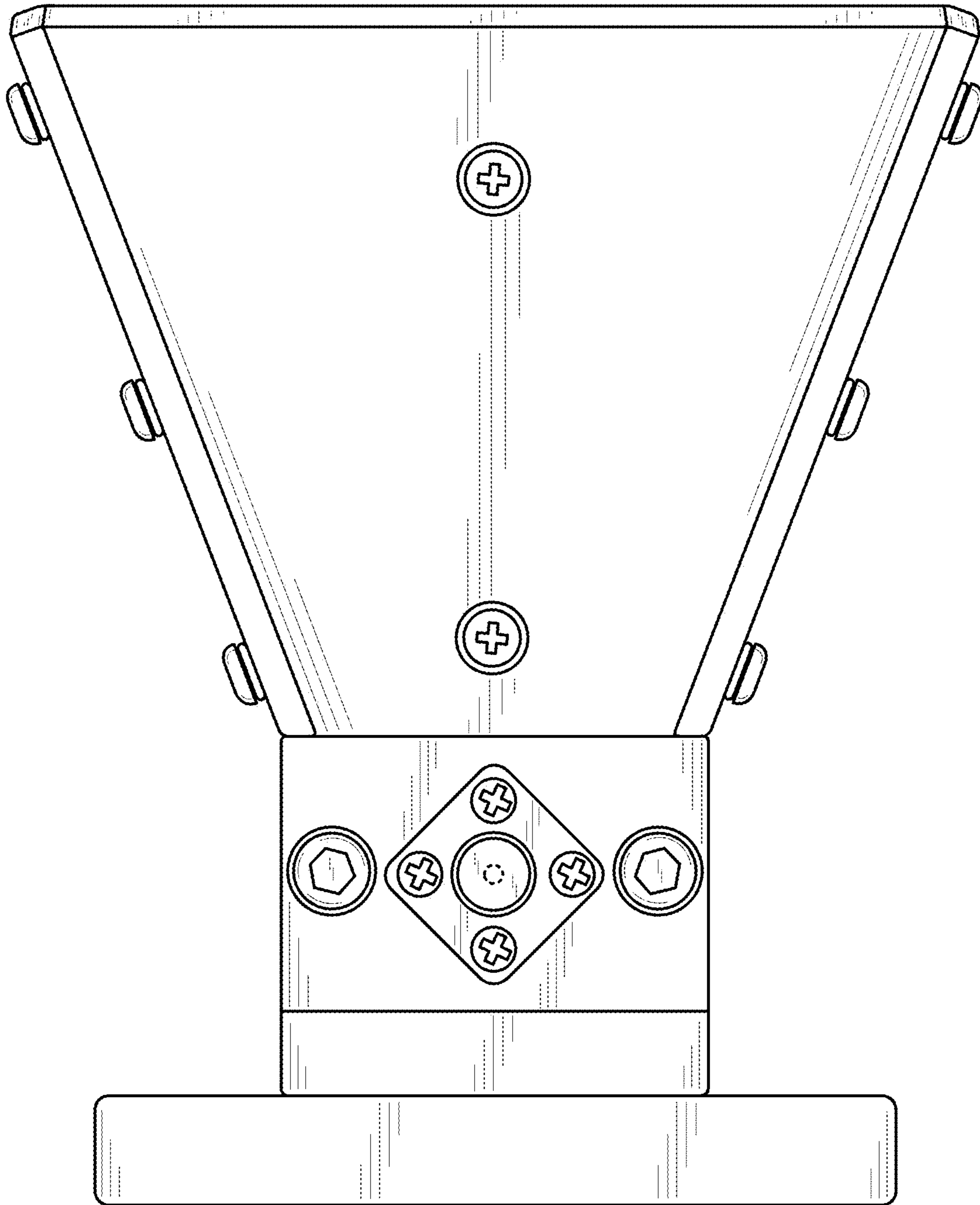

FIG. 3

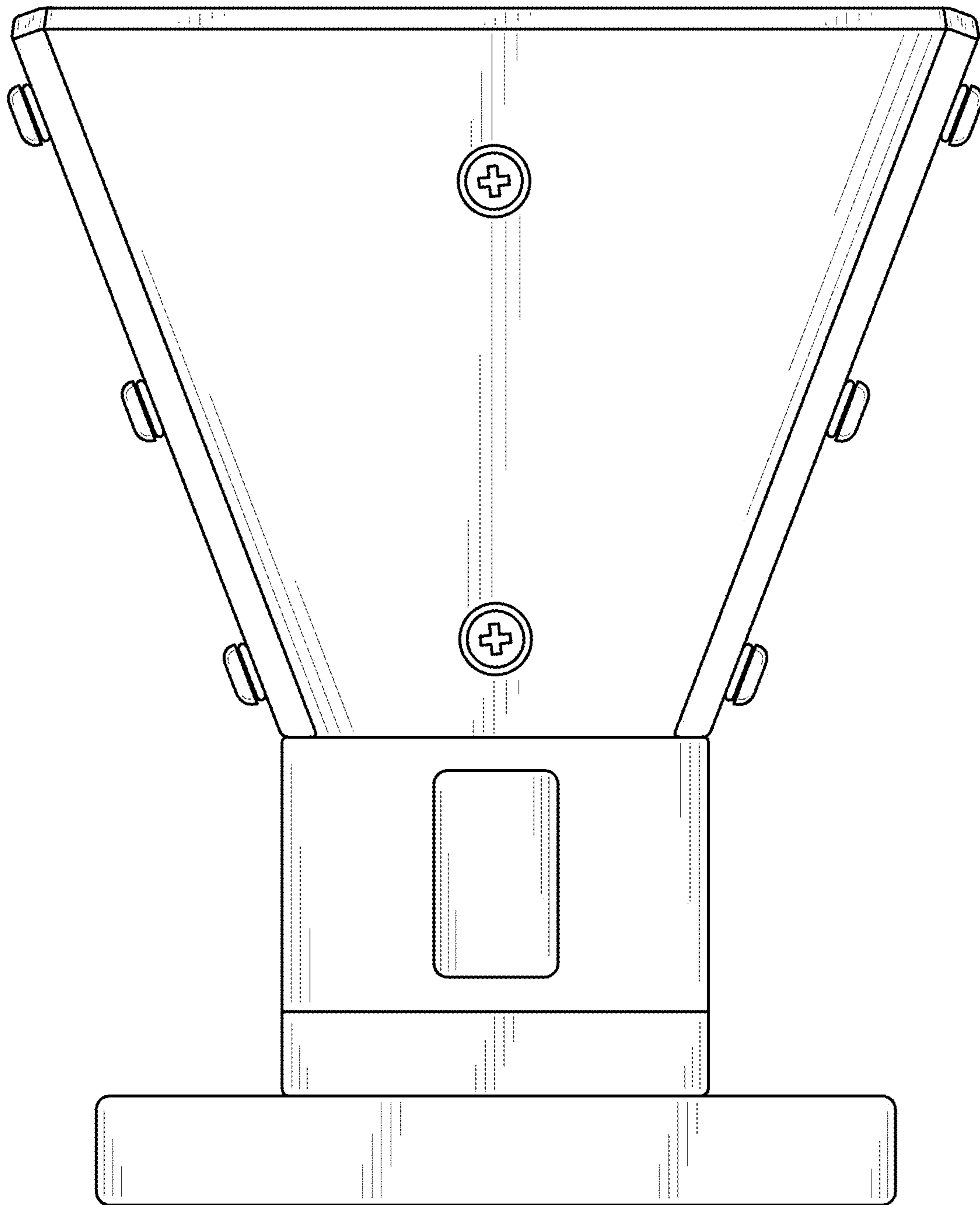

FIG. 4

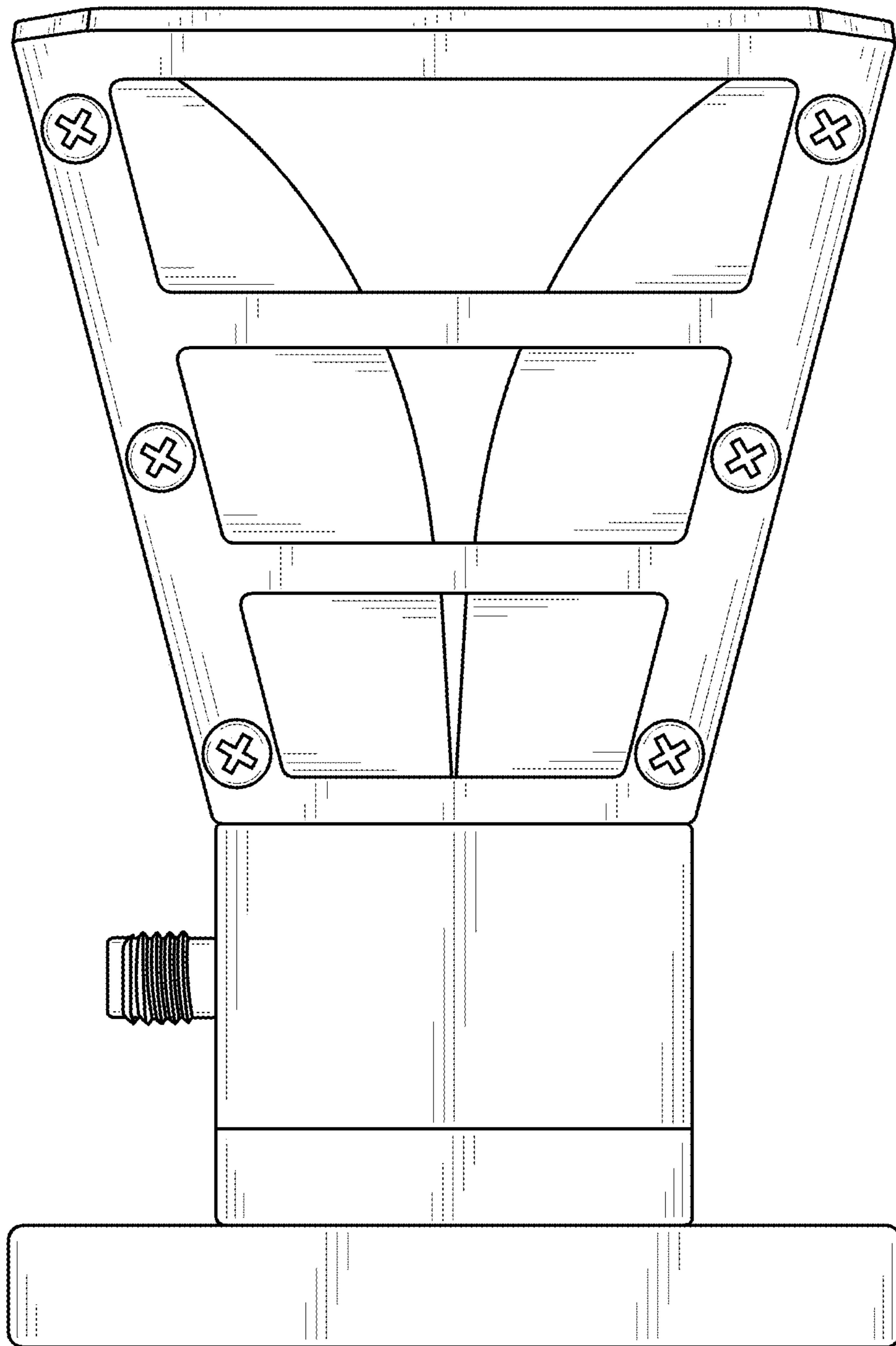

FIG. 5

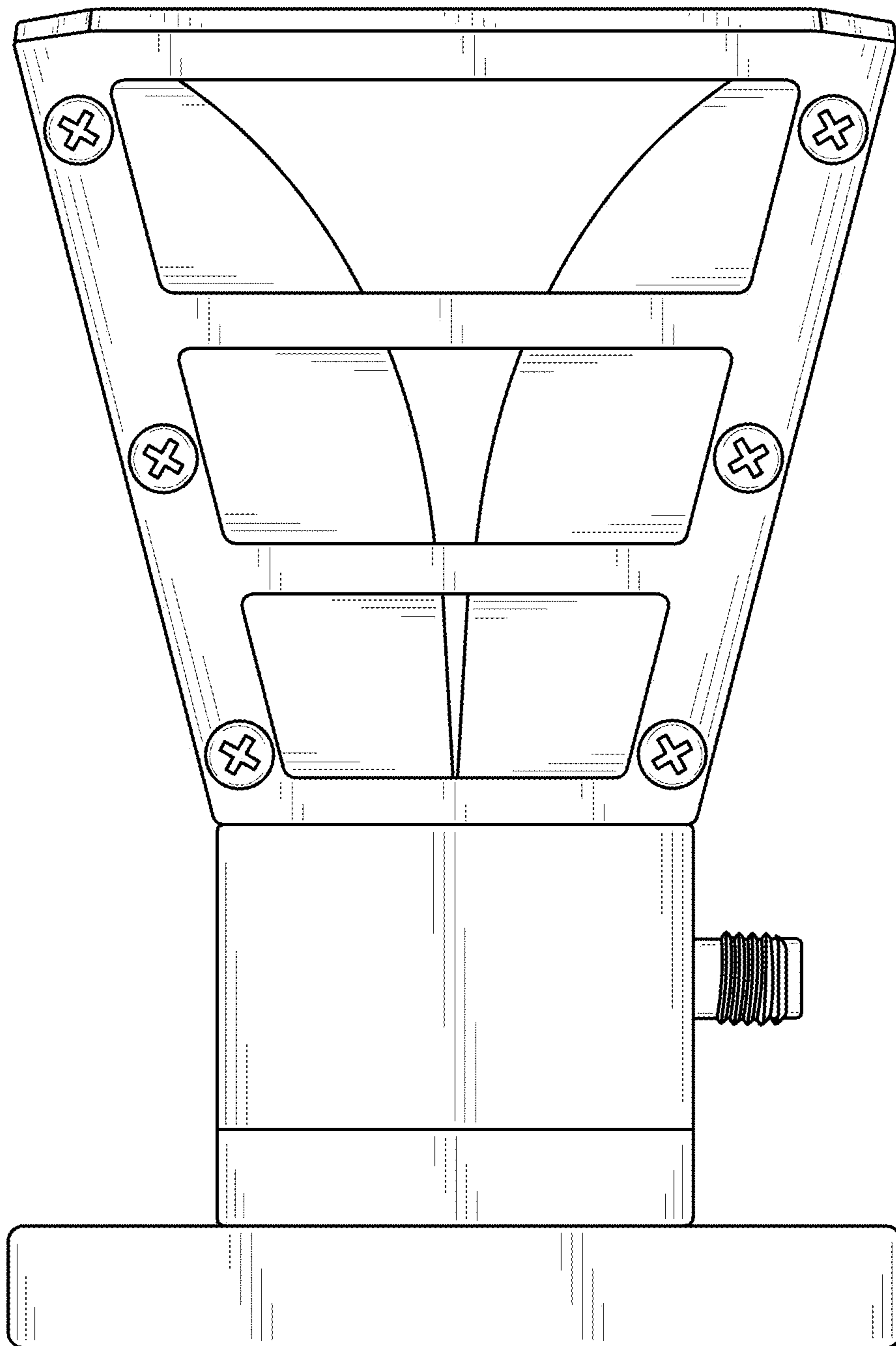

FIG. 6



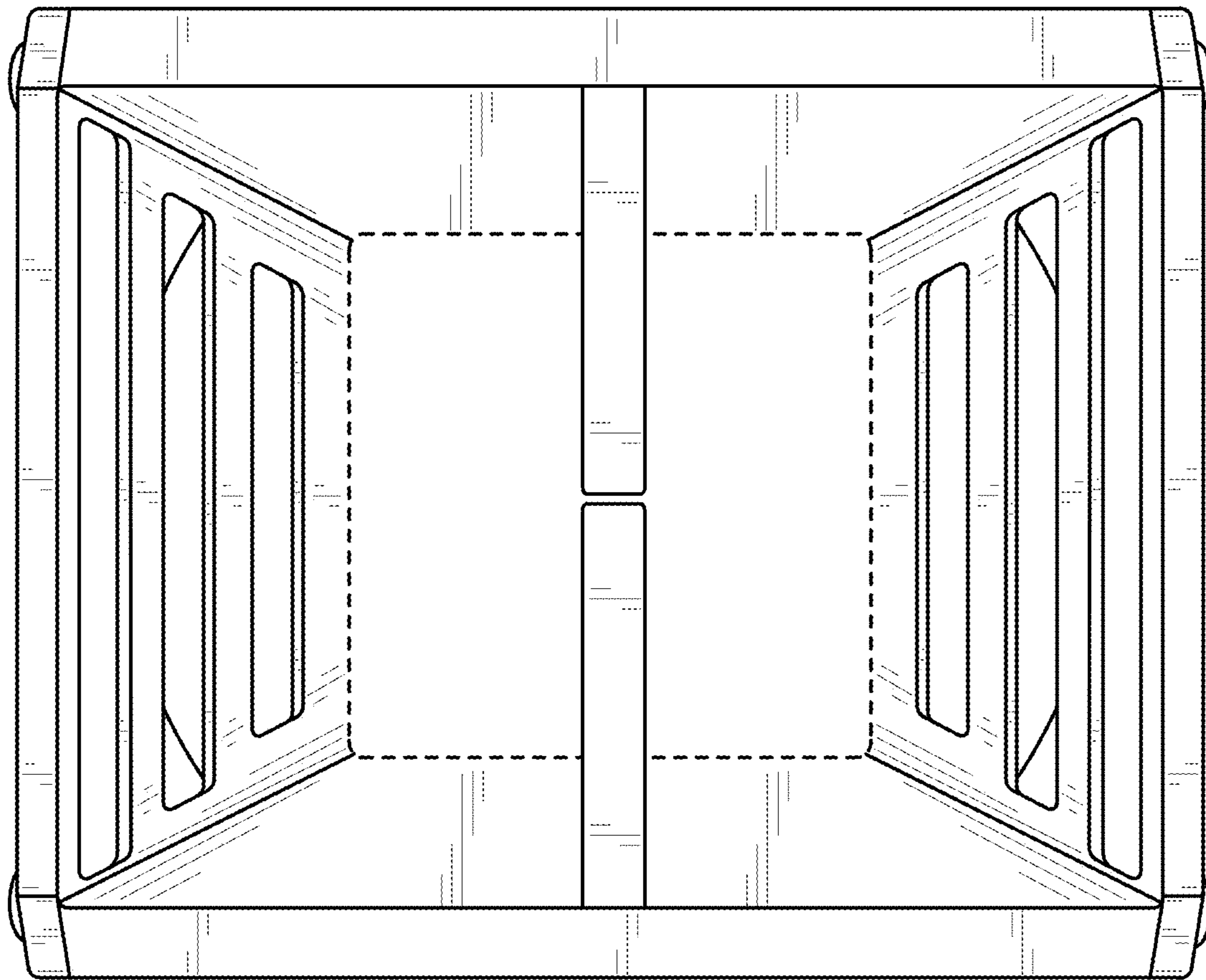

FIG. 7

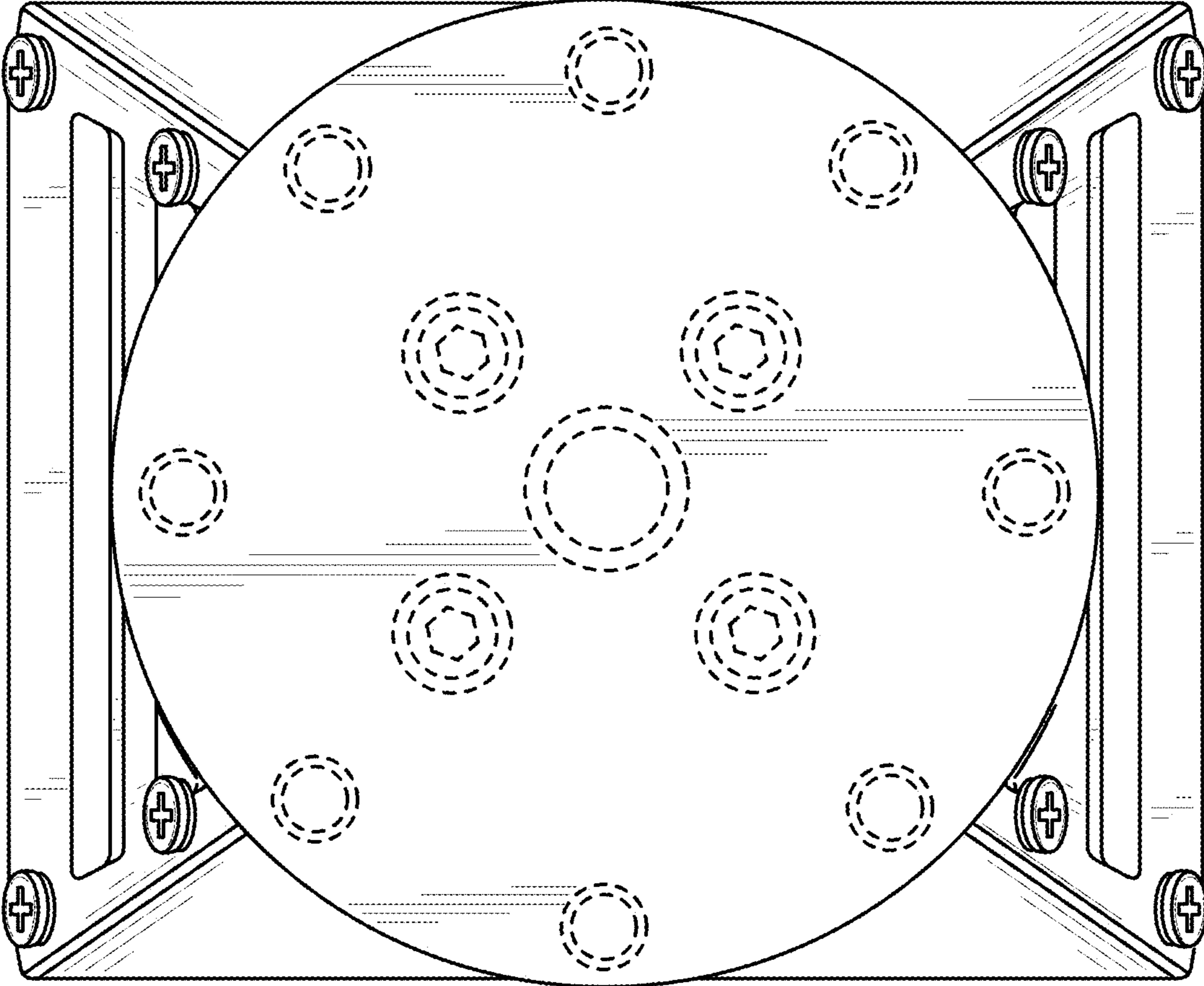

FIG. 8