



US00D977070S

(12) **United States Design Patent**
Enzaki

(10) **Patent No.:** **US D977,070 S**
(45) **Date of Patent:** **** Jan. 31, 2023**

(54) **ELECTROMAGNETIC VALVE**
(71) Applicant: **SMC CORPORATION**, Tokyo (JP)
(72) Inventor: **Akira Enzaki**, Bando (JP)
(73) Assignee: **SMC CORPORATION**, Tokyo (JP)

D698,900 S * 2/2014 Narita D23/233
D752,181 S * 3/2016 Matsumura D23/233
D908,737 S * 1/2021 Nemoto D15/7
D909,536 S * 2/2021 Yoshimura D23/233
D909,537 S * 2/2021 Yoshimura D23/233
D909,538 S * 2/2021 Yoshimura D23/233

(Continued)

(**) Term: **15 Years**
(21) Appl. No.: **29/769,462**
(22) Filed: **Feb. 5, 2021**

FOREIGN PATENT DOCUMENTS

IN 327726-001-0001 * 2/2021

(30) **Foreign Application Priority Data**

Sep. 7, 2020 (JP) 2020-019023 D

(51) **LOC (14) Cl.** **23-01**

(52) **U.S. Cl.**
USPC **D23/233**

(58) **Field of Classification Search**
USPC D23/233, 235, 248; 438/3, 637, 589;
D15/5, 7, 9; D13/110, 123

CPC .. Y02E 60/10; F15B 15/1452; F15B 15/1447;
F15B 15/2807; F15B 15/1471; F15B
15/1423; F15B 15/2861; F15B 15/2892;
F15B 15/223; F15B 15/1414; F15B
13/0871; F15B 13/0807; F15B 13/0814;
F15B 13/0842; F15B 15/1419; F15B
15/226; F15B 11/068; F15B 2211/853;
F15B 2211/8636; F15B 2211/40515;
F15B 2211/851; F15B 2211/8757; F15B
2211/8855; F16K 27/041; F16K 11/22;
F16K 27/003; F16K 27/048; F16K 11/07;
F16K 1/52; F16K 17/30; G05D 7/03;
Y10T 137/86614

See application file for complete search history.

(56) **References Cited**

U.S. PATENT DOCUMENTS

D698,418 S * 1/2014 Narita D23/233
D698,899 S * 2/2014 Narita D23/233

OTHER PUBLICATIONS

The Electromagnetic Valve KL460 Series, available on genndih.com, posted on Dec. 2, 2020 [online] [site visited Aug. 3, 2022], Internet URL: https://www.genndih.com/upload_files/download/pdf/KL460.pdf (Year: 2020).*

Primary Examiner — Amy C Wierenga
Assistant Examiner — Andrea Marie McKay
(74) *Attorney, Agent, or Firm* — Oblon, McClelland, Maier & Neustadt, L.L.P.

(57) **CLAIM**

The ornamental design for an electromagnetic valve, as shown and described.

DESCRIPTION

FIG. 1 is a front, top, and left side perspective view of an electromagnetic valve showing the new design.
FIG. 2 is a rear, bottom, and right side perspective view thereof.
FIG. 3 is a front elevational view thereof.
FIG. 4 is a rear elevational view thereof.
FIG. 5 is a top plan view thereof.
FIG. 6 is a bottom plan view thereof.
FIG. 7 is a left side elevational view thereof; and,
FIG. 8 is a right side elevational view thereof.
The broken lines depict portions of the electromagnetic valve that form no part of the claimed design.

1 Claim, 8 Drawing Sheets

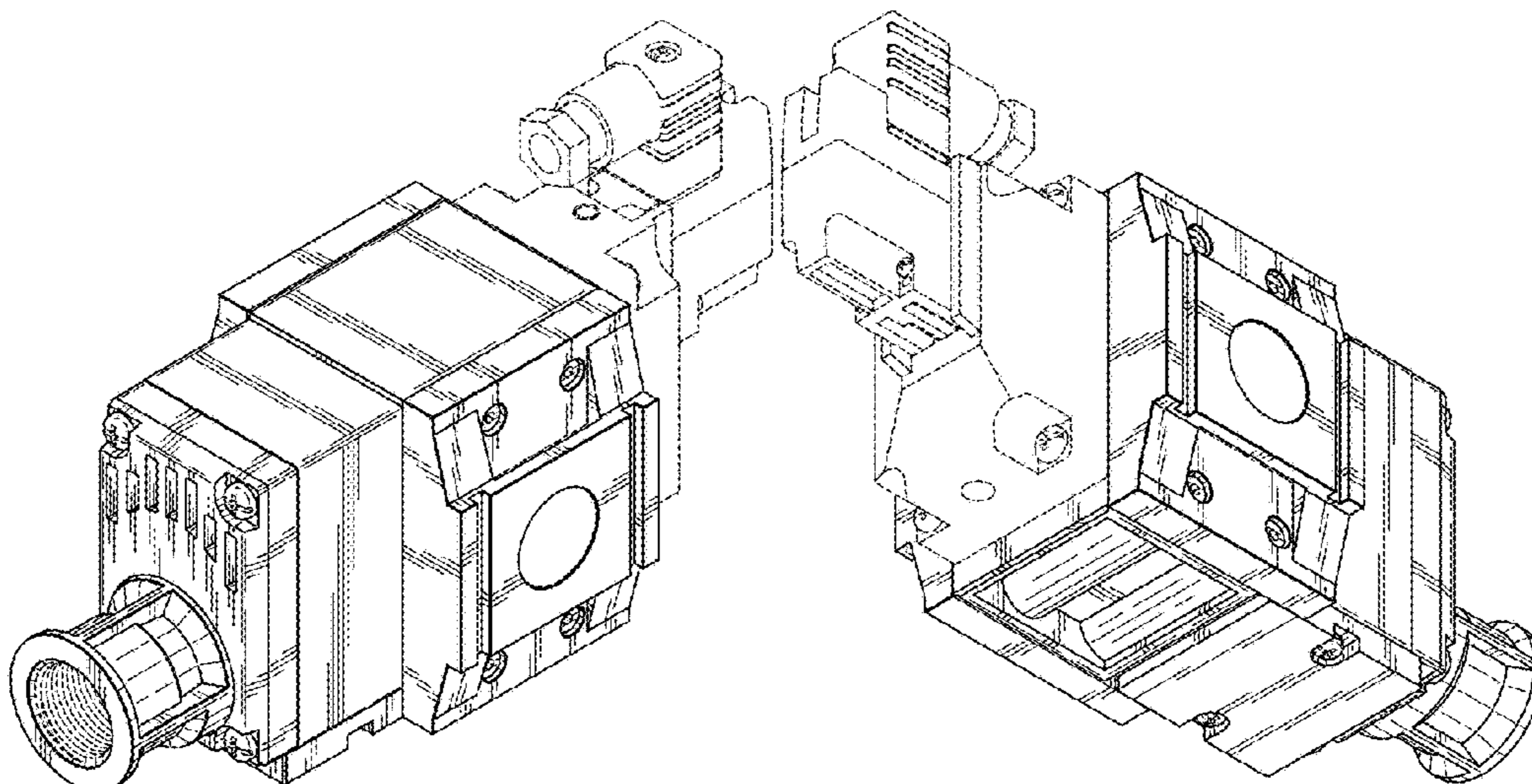

(56)

References Cited

U.S. PATENT DOCUMENTS

D910,147 S *	2/2021	Yoshimura	D23/233
D910,148 S *	2/2021	Yoshimura	D23/233
D910,814 S *	2/2021	Yoshimura	D23/233
D910,815 S *	2/2021	Yoshimura	D23/233
D912,206 S *	3/2021	Yoshimura	D23/233
D920,909 S *	6/2021	Sakamura	D13/110
D924,361 S *	7/2021	Matsushita	D23/235
D926,935 S *	8/2021	Matsushita	D23/235
D934,995 S *	11/2021	Mita	D23/233
D935,560 S *	11/2021	Mita	D23/233
D946,712 S *	3/2022	Yoshimura	D23/233
D961,731 S *	8/2022	Hara	D23/233

* cited by examiner

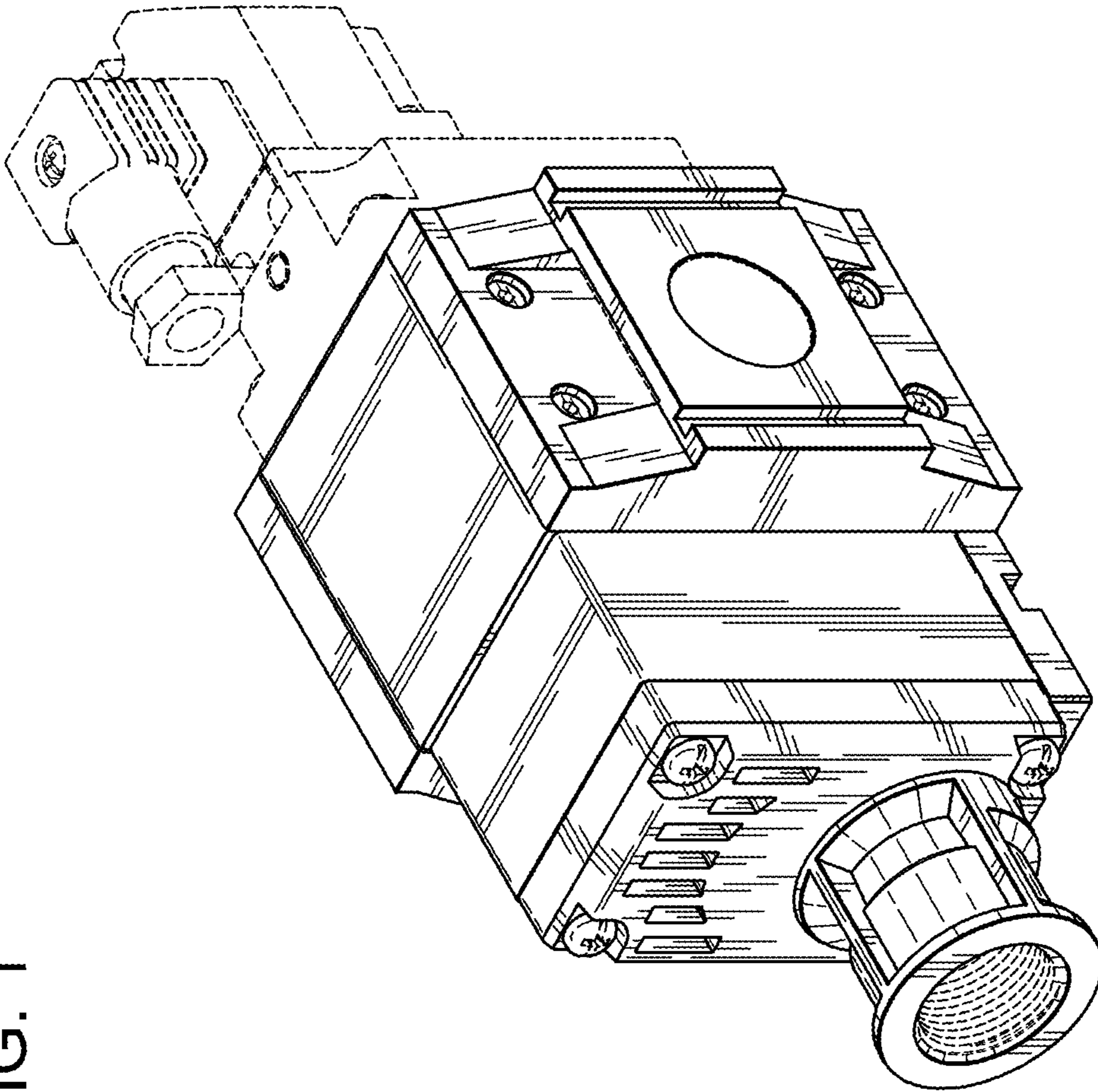
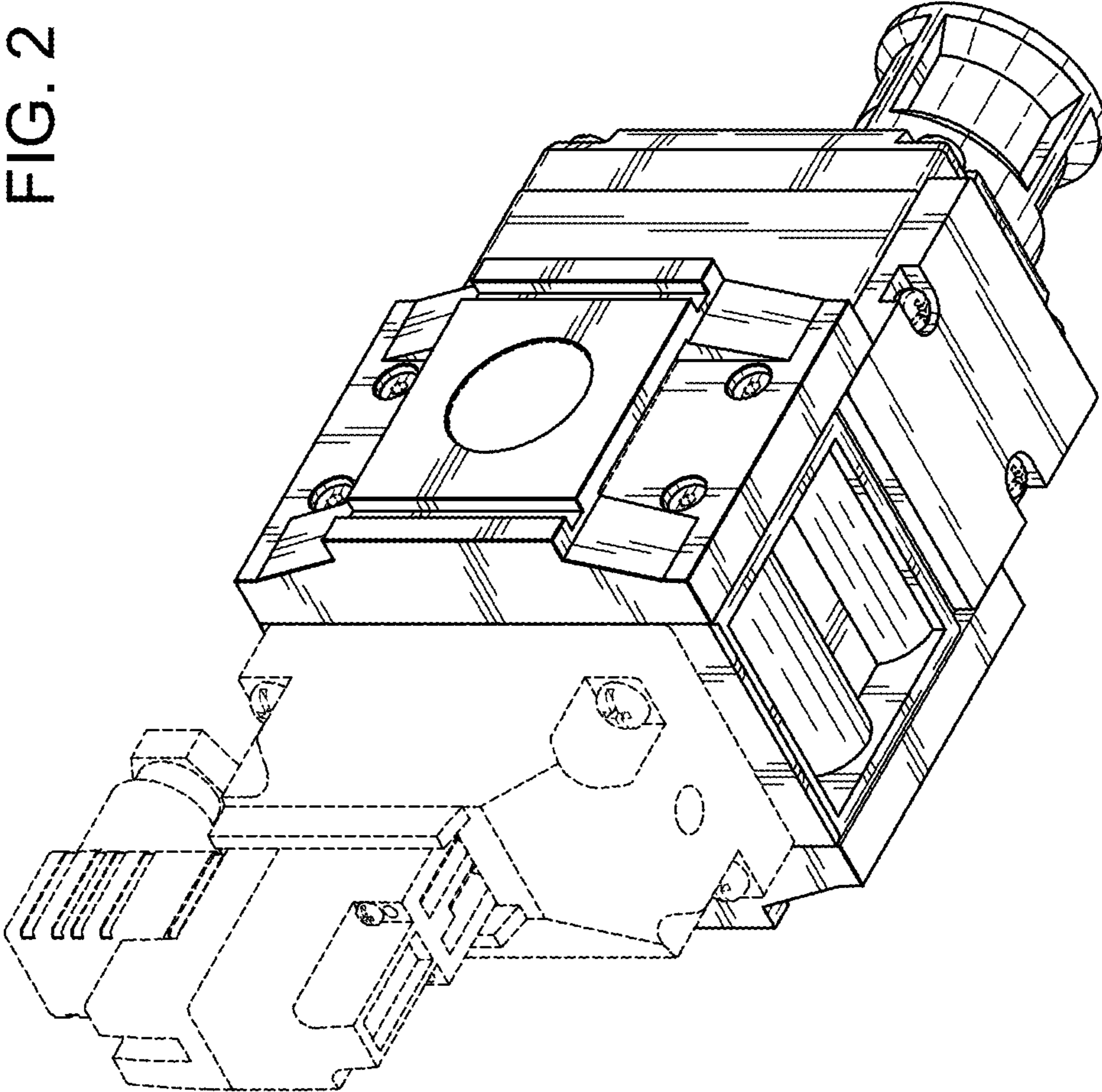

FIG. 1

FIG. 2



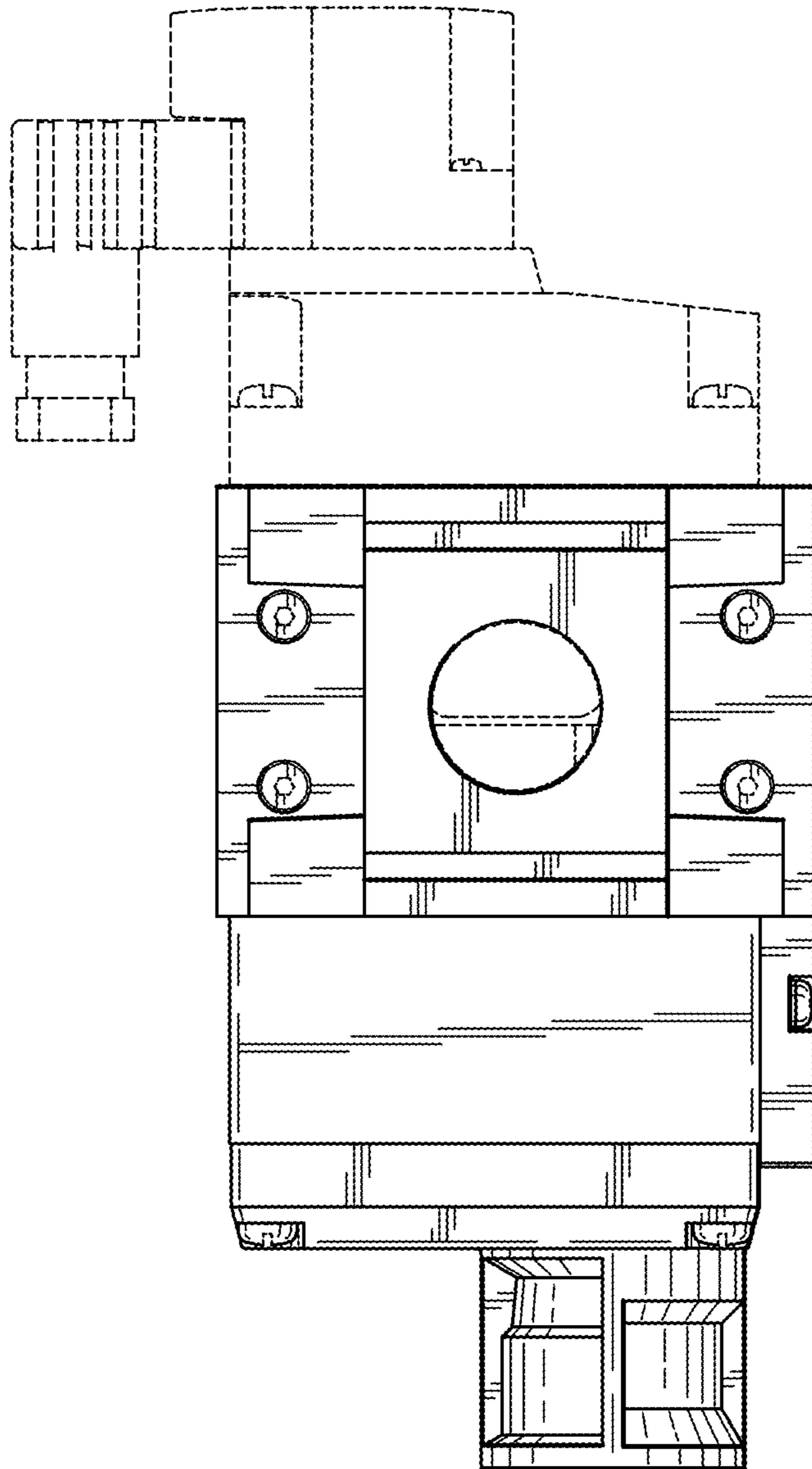

FIG. 3

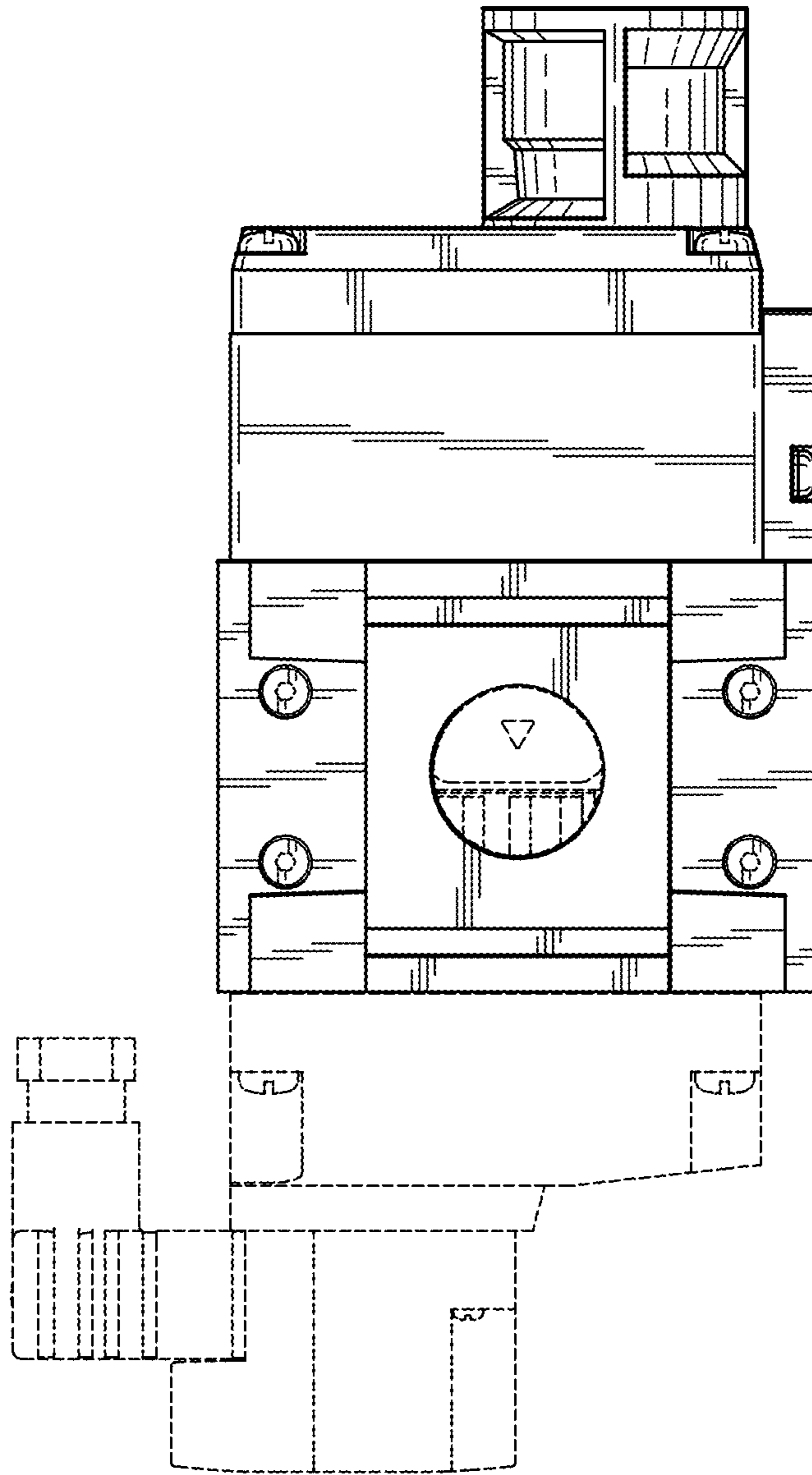

FIG. 4

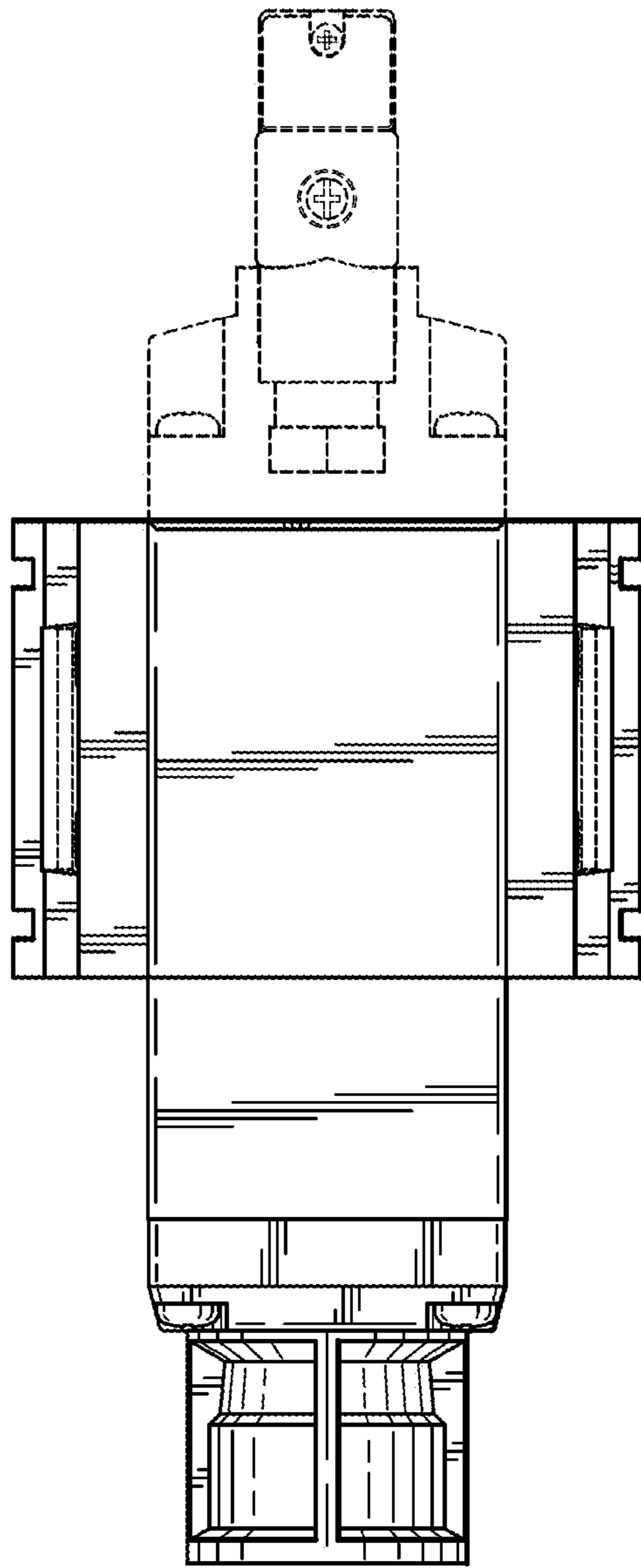

FIG. 5

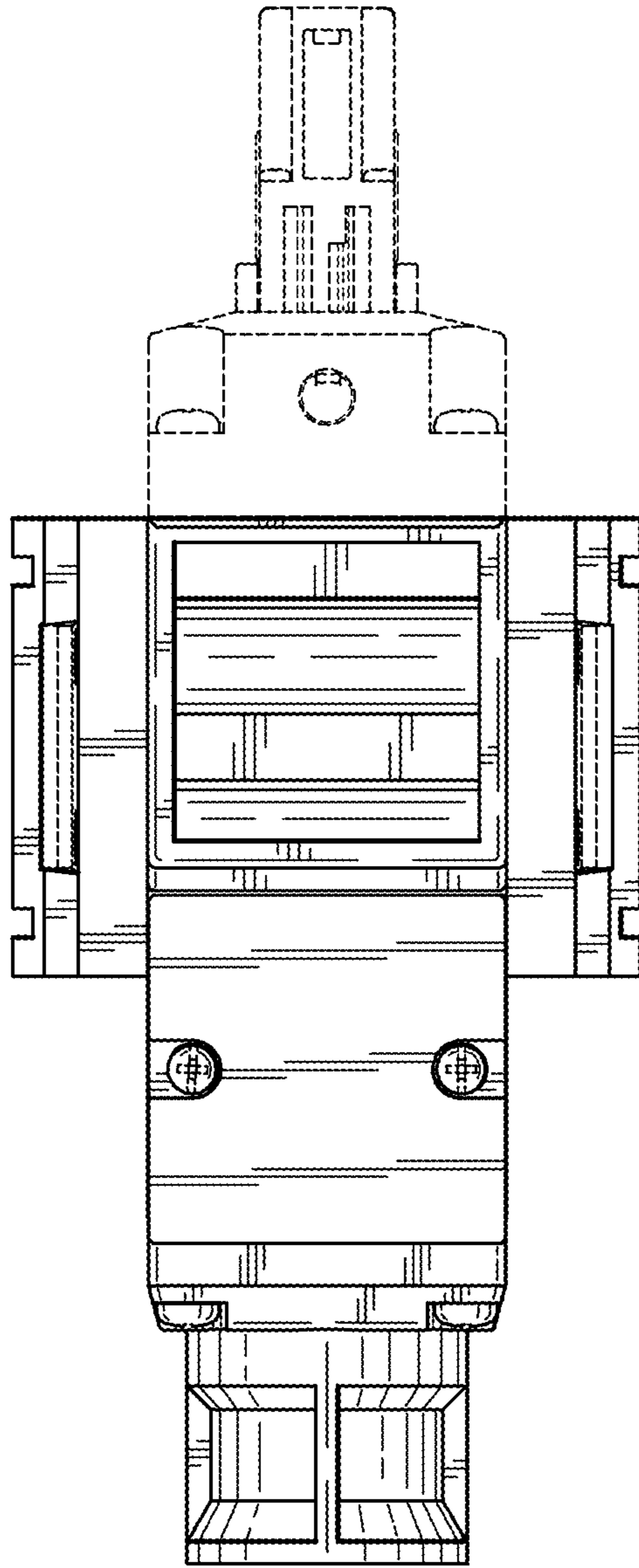

FIG. 6

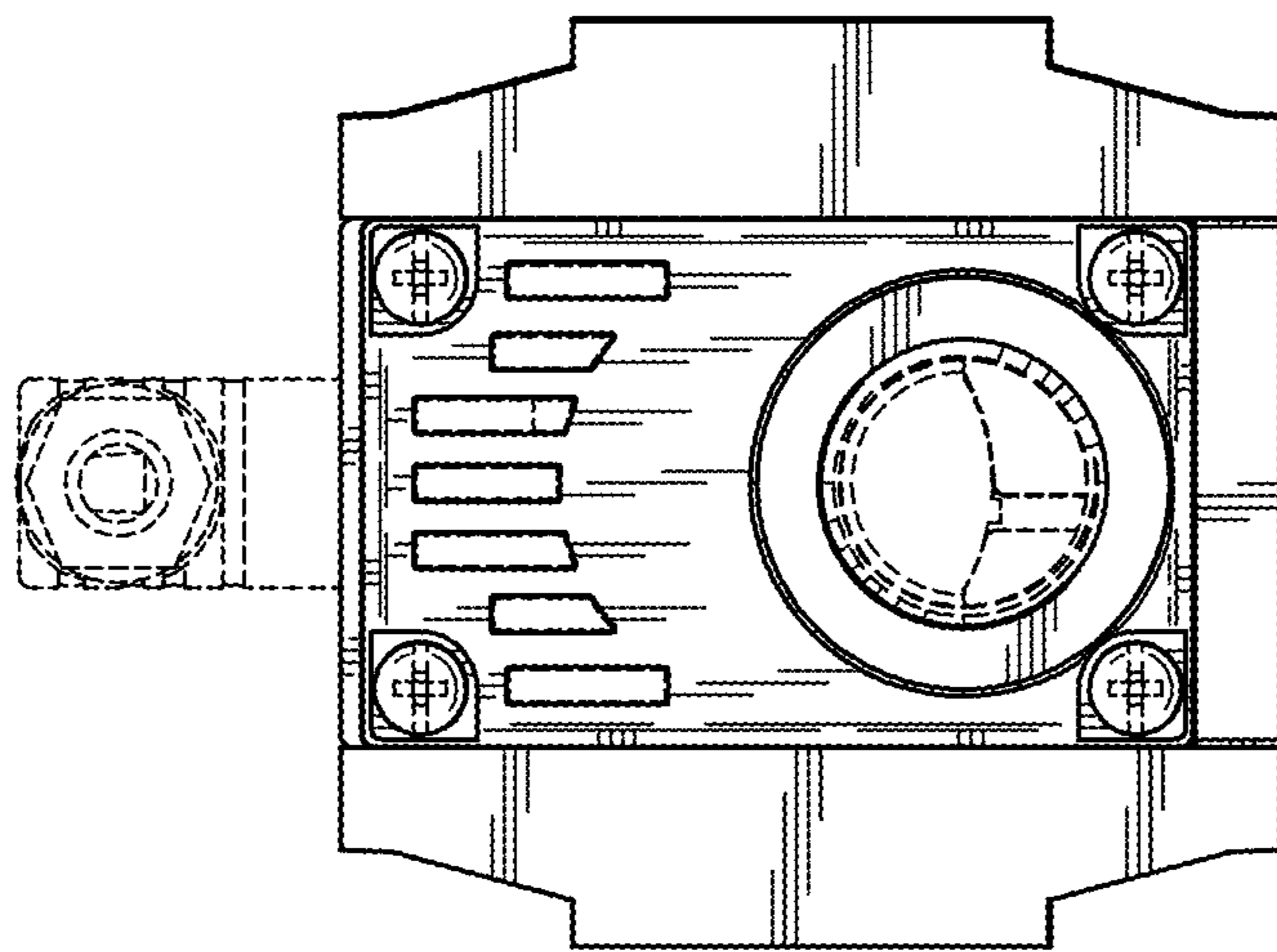

FIG. 7

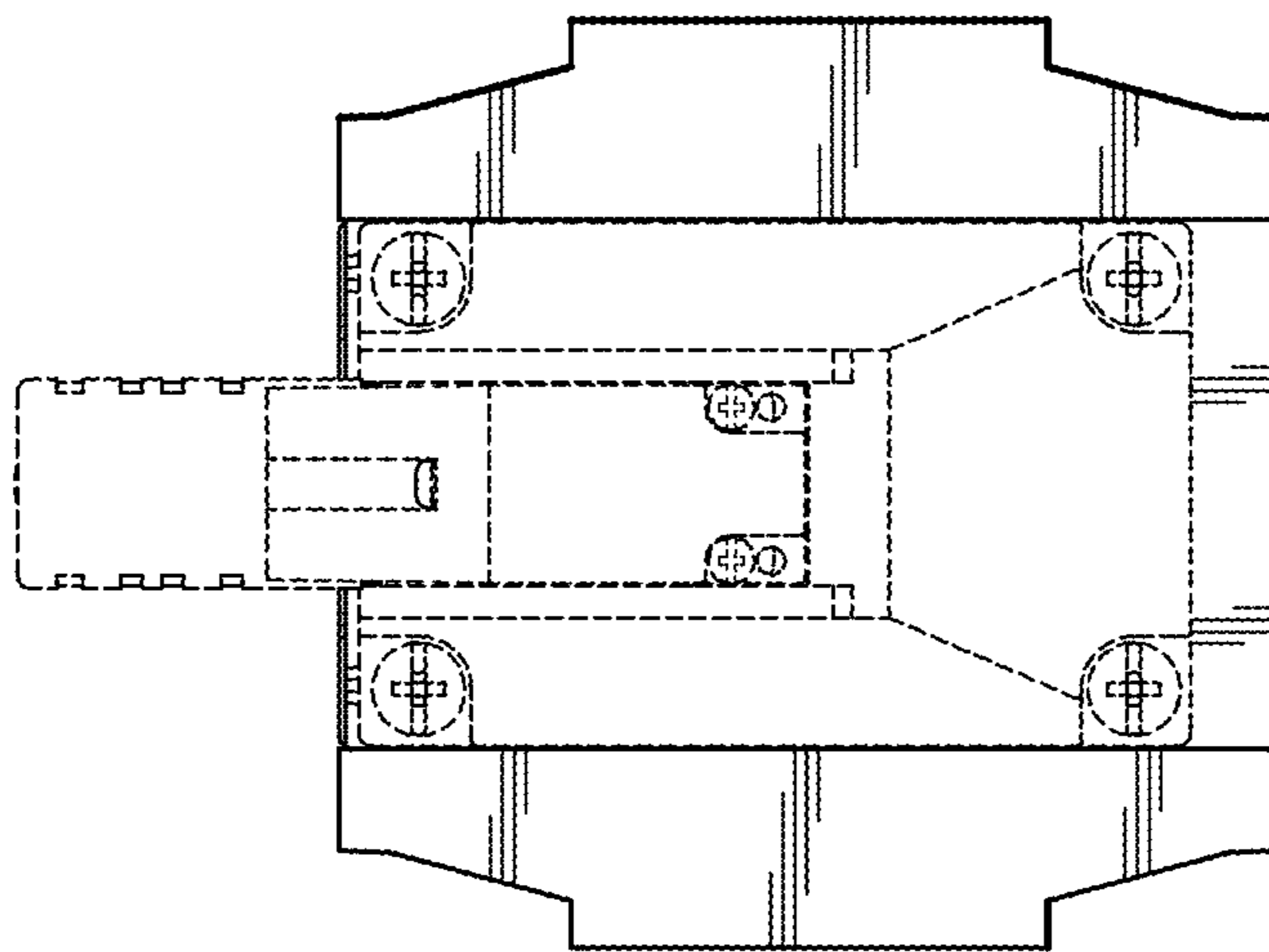

FIG. 8