



US00D977019S

(12) **United States Design Patent** (10) **Patent No.:** **US D977,019 S**
Lu (45) **Date of Patent:** **** Jan. 31, 2023**

(54) **ELECTRIC SCOOTER**

D911,457 S * 2/2021 Yu D21/423
D912,159 S * 3/2021 Lee D21/423
D919,712 S * 5/2021 Gao D21/423

(71) Applicant: **Zhejiang Okai Vehicle Co., Ltd.**,
Lishui (CN)

(Continued)

(72) Inventor: **Jiangtao Lu**, Lishui (CN)

FOREIGN PATENT DOCUMENTS

(73) Assignee: **ZHEJIANG OKAI VEHICLE CO., LTD.**,
Lishui (CN)

CN 303552129 * 1/2016 B62J 1/08
CN 304620319 * 5/2018 B62K 15/006
CN 108974223 A * 12/2018 B62J 1/08
CN 305582158 * 1/2020
CN 111703528 A * 9/2020 B62H 5/001

(Continued)

(**) Term: **15 Years**

(21) Appl. No.: **29/738,572**

OTHER PUBLICATIONS

(22) Filed: **Jun. 18, 2020**

Dan Keshet, "Lockless and Flockless: The State of Austin's Dockless Vehicle Pilot Program," Jun. 8, 2018, austin.towers.net, site visited Aug. 23, 2021, URL: <https://austin.towers.net/lockless-and-flockless-the-state-of-austins-dockless-vehicle-pilot-program/> (Year: 2018).*

(Continued)

(30) **Foreign Application Priority Data**

Apr. 8, 2020 (CN) 202030134482.6

(51) **LOC (14) Cl.** **21-01**

(52) **U.S. Cl.**

USPC **D21/423**

(58) **Field of Classification Search**

USPC D21/419, 421, 423, 760, 765, 771;
D12/1, 8, 107, 110, 112-114

CPC . B62K 3/002; B62K 9/00; B62K 9/02; B62K
2202/00; B62K 13/00; B62K 11/00;
B62K 11/02; B62K 11/06; B62K 11/10;
B62K 15/00; B62K 17/00; B60Y
2200/126; H04W 4/40

See application file for complete search history.

Primary Examiner — Eric L Goodman

Assistant Examiner — Sarah L Smith

(74) *Attorney, Agent, or Firm* — Muncy, Geissler, Olds & Lowe, P.C.

(57)

CLAIM

The ornamental design for an electric scooter, as shown and described.

DESCRIPTION

FIG. 1 is a front, right, top perspective view of an electric scooter showing my new design;

FIG. 2 is a front elevational view thereof;

FIG. 3 is a rear elevational view thereof;

FIG. 4 is a right side elevational view thereof;

FIG. 5 is a left side elevational view thereof;

FIG. 6 is a top plan view thereof; and,

FIG. 7 is a bottom plan view thereof.

The broken lines illustrate portions of the electric scooter which form no part of the claimed design.

1 Claim, 7 Drawing Sheets

(56) **References Cited**

U.S. PATENT DOCUMENTS

D638,489 S * 5/2011 Scolari B62K 11/14
D21/423
8,025,305 B1 * 9/2011 Lin B62H 1/02
280/301
D886,907 S * 6/2020 Gao D21/423
D889,557 S * 7/2020 Cao D21/423
D900,237 S * 10/2020 Lee D21/423
D905,793 S * 12/2020 Yang D21/423

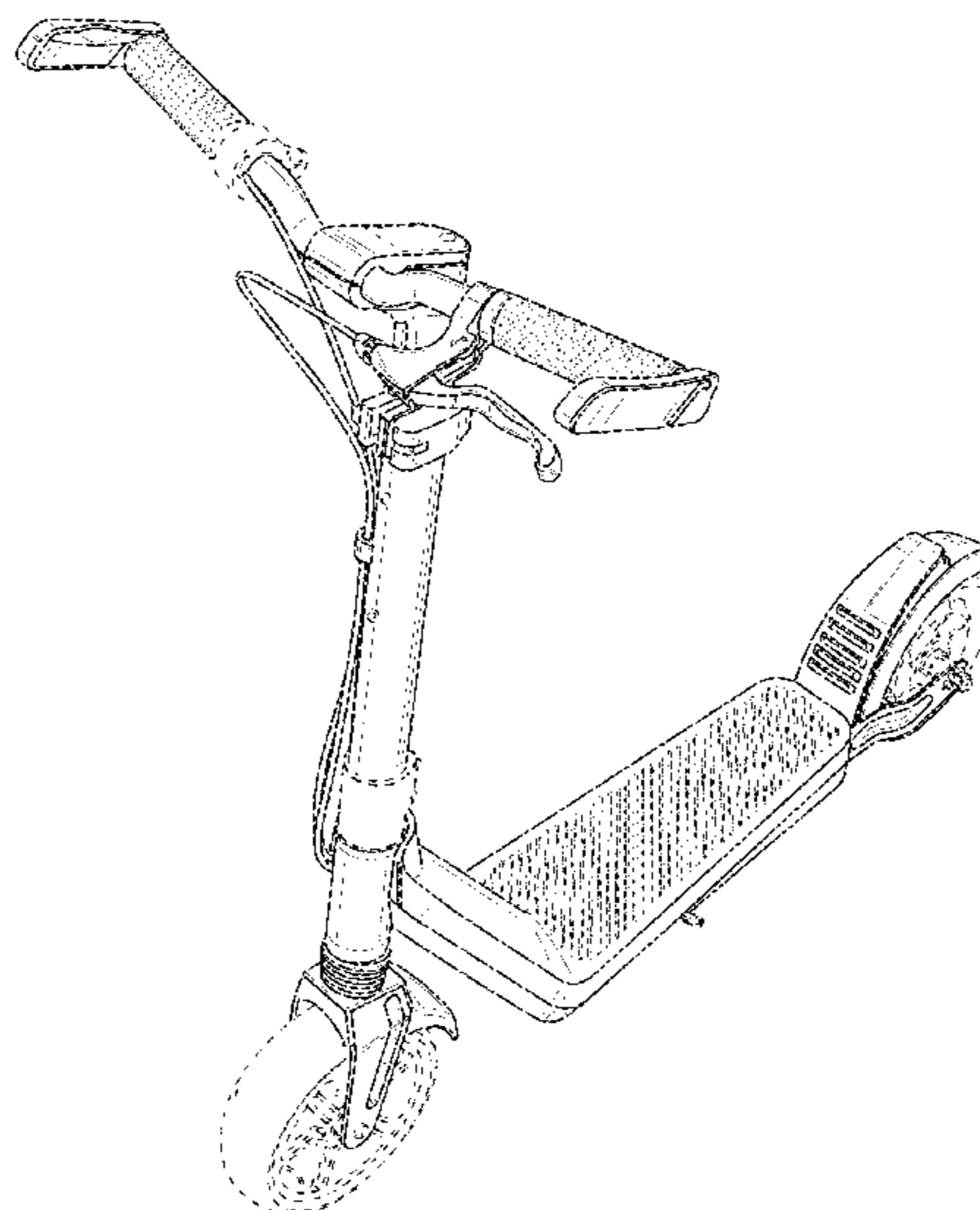

(56)

References Cited

U.S. PATENT DOCUMENTS

D922,306 S * 6/2021 Dongfang D12/423
D923,103 S * 6/2021 Zheng B62H 1/02
D21/423
D923,714 S * 6/2021 Shen D21/423
D927,604 S * 8/2021 Han D21/423
D958,900 S * 7/2022 Liu D21/423
2002/0030339 A1 * 3/2002 Powers B62J 6/045
188/19
2020/0283086 A1 * 9/2020 Ulmen B62K 11/14
2021/0179220 A1 * 6/2021 Ottenssooser B62K 3/002

FOREIGN PATENT DOCUMENTS

DE 102018107492 A1 * 10/2019 B62K 15/006
WO WO-2016045156 A1 * 3/2016 B62K 11/00

OTHER PUBLICATIONS

“Electric Scooters in Austin: What Are the Rules?” Mar. 21, 2019, fvflawfirm.com, site visited Aug. 23, 2021, URL: <https://www.fvflawfirm.com/electric-scooters-austin-rules/> (Year: 2019).*

Nick Start, “A Cyclone of Scooters has Descended on Austin for SXSW, for Better or Worse,” Mar. 11, 2019, theverge.com, site visited Aug. 23, 2021, URL: <https://www.theverge.com/2019/3/11/18260154/austin-scooters-bird-lime-uber-jump-sxsw-2019-dangerous-future-urban-transit> (Year: 2019).*

“E-scooter company Unicorn goes bust after spending big on Facebook ads,” Dec. 9, 2019, bbc.com, site visited Aug. 23, 2021, URL: <https://www.bbc.com/news/technology-50713723> (Year: 2019).*

* cited by examiner

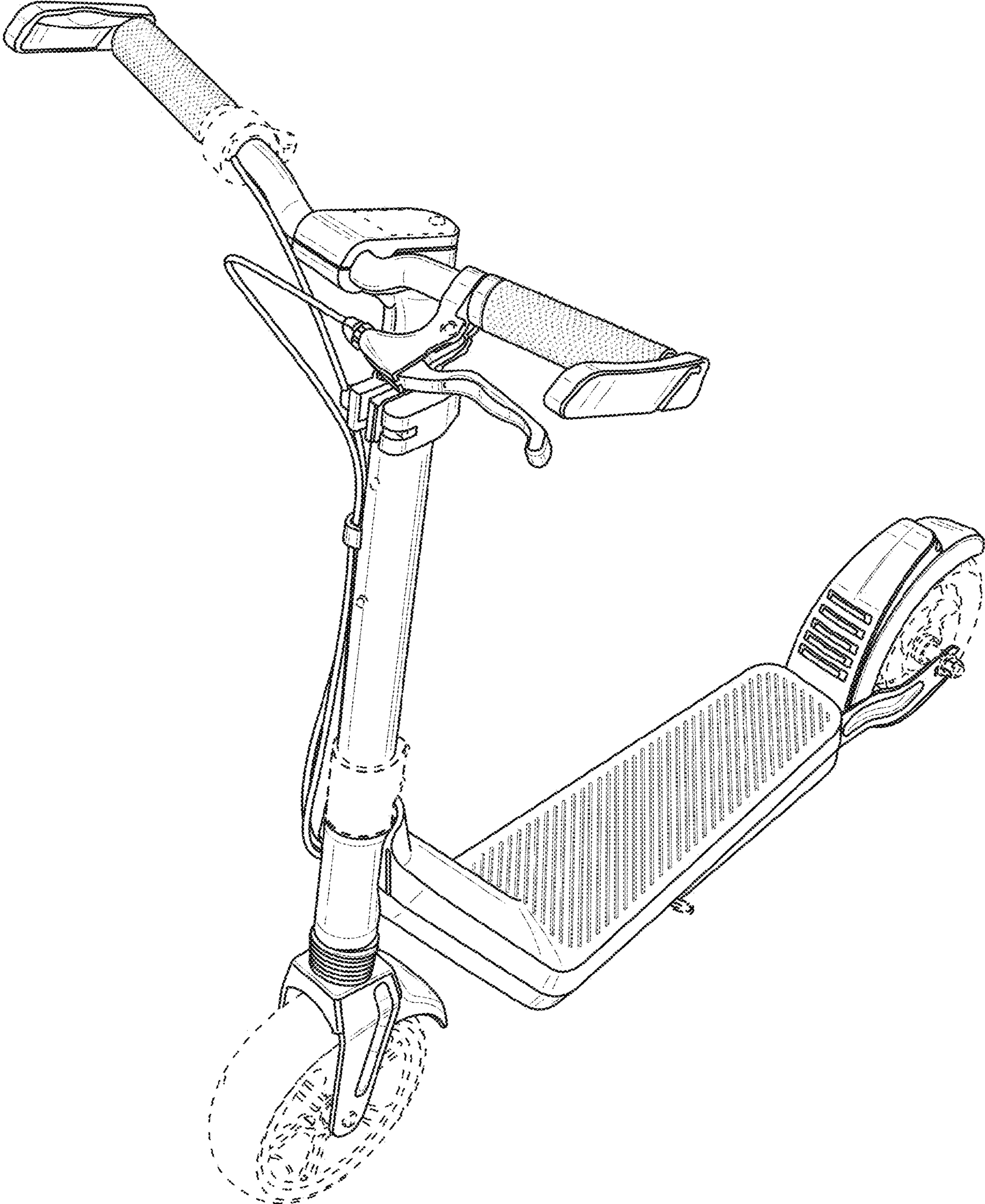

FIG. 1

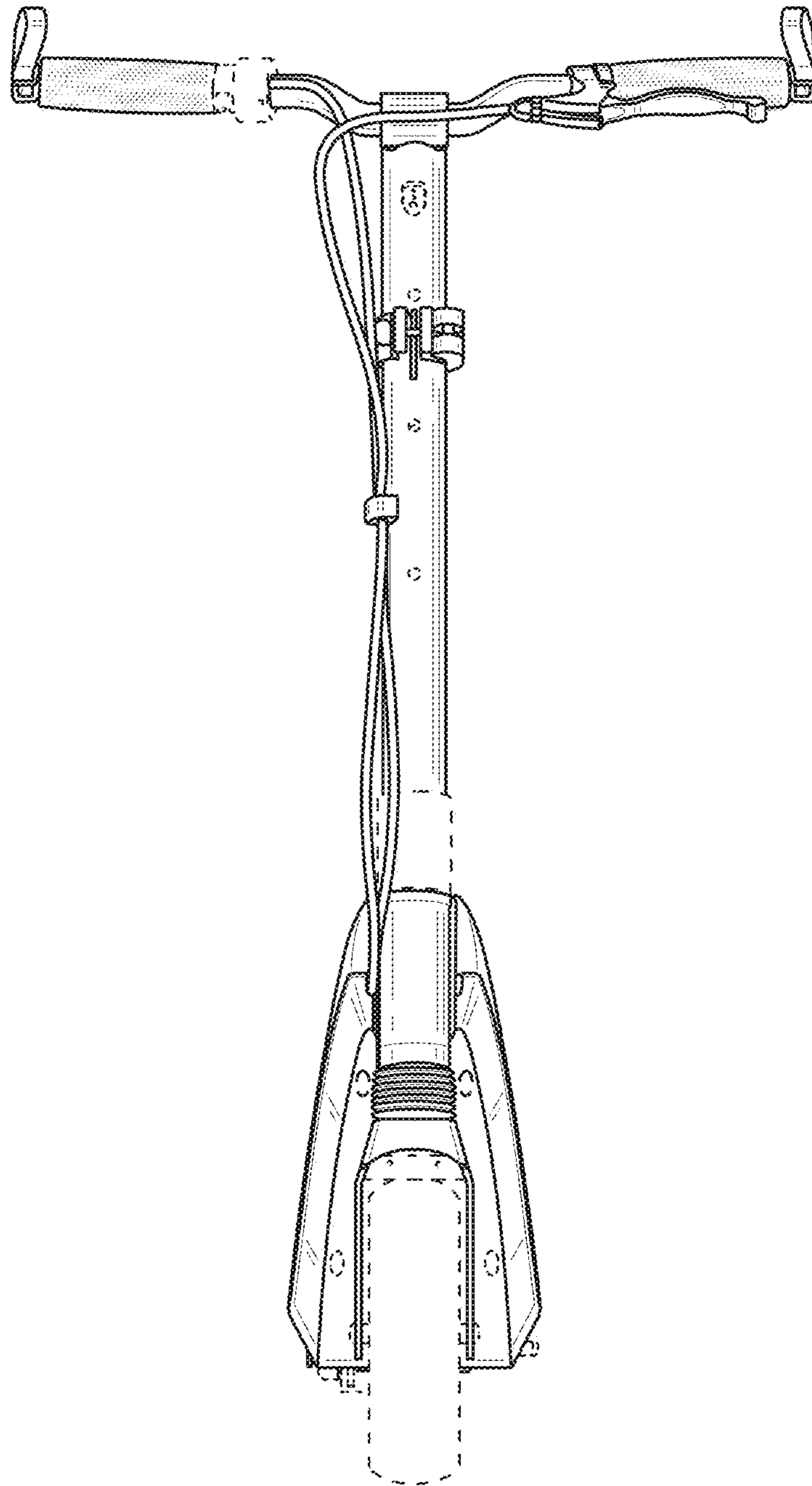

FIG. 2

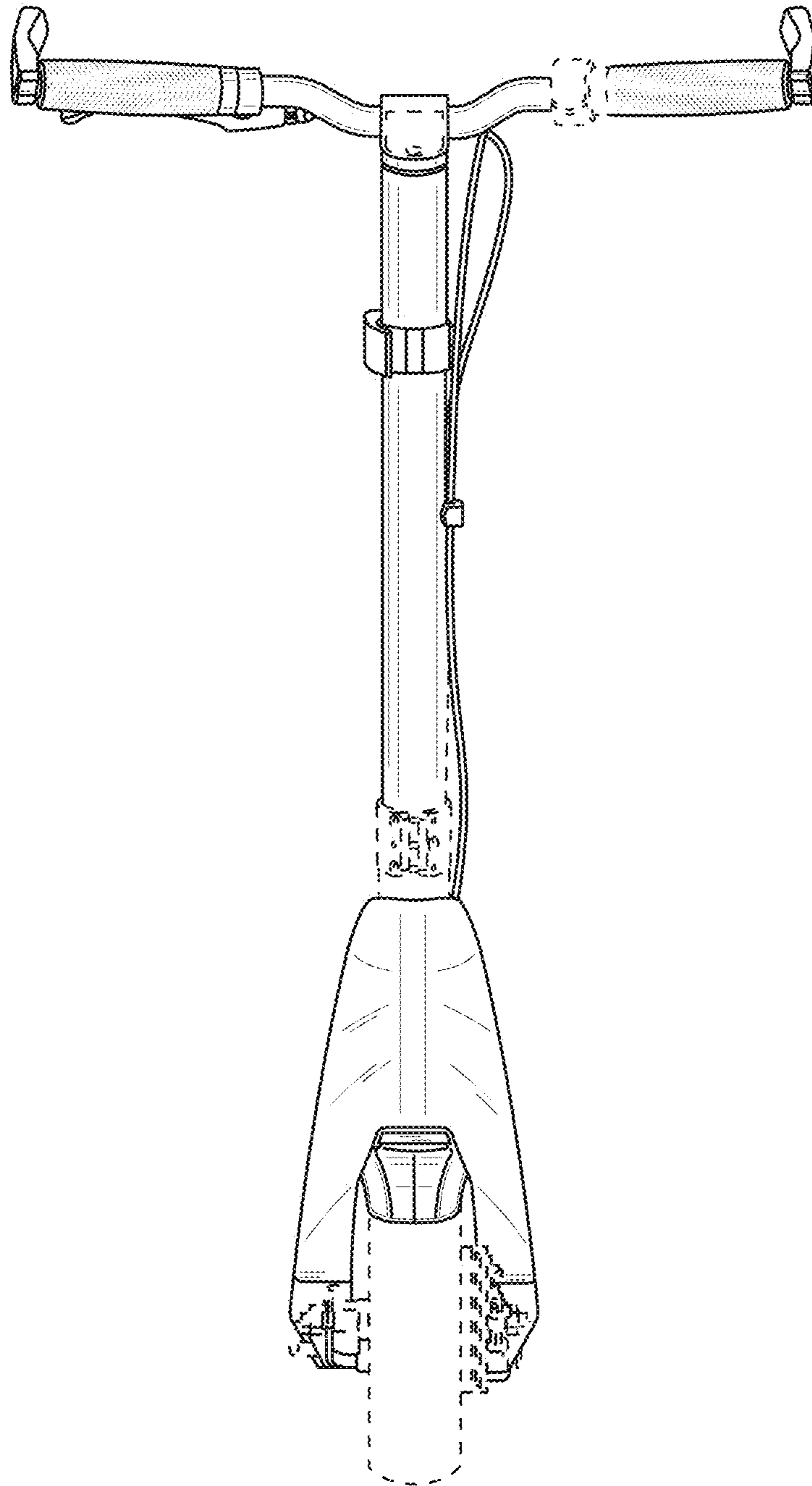

FIG. 3

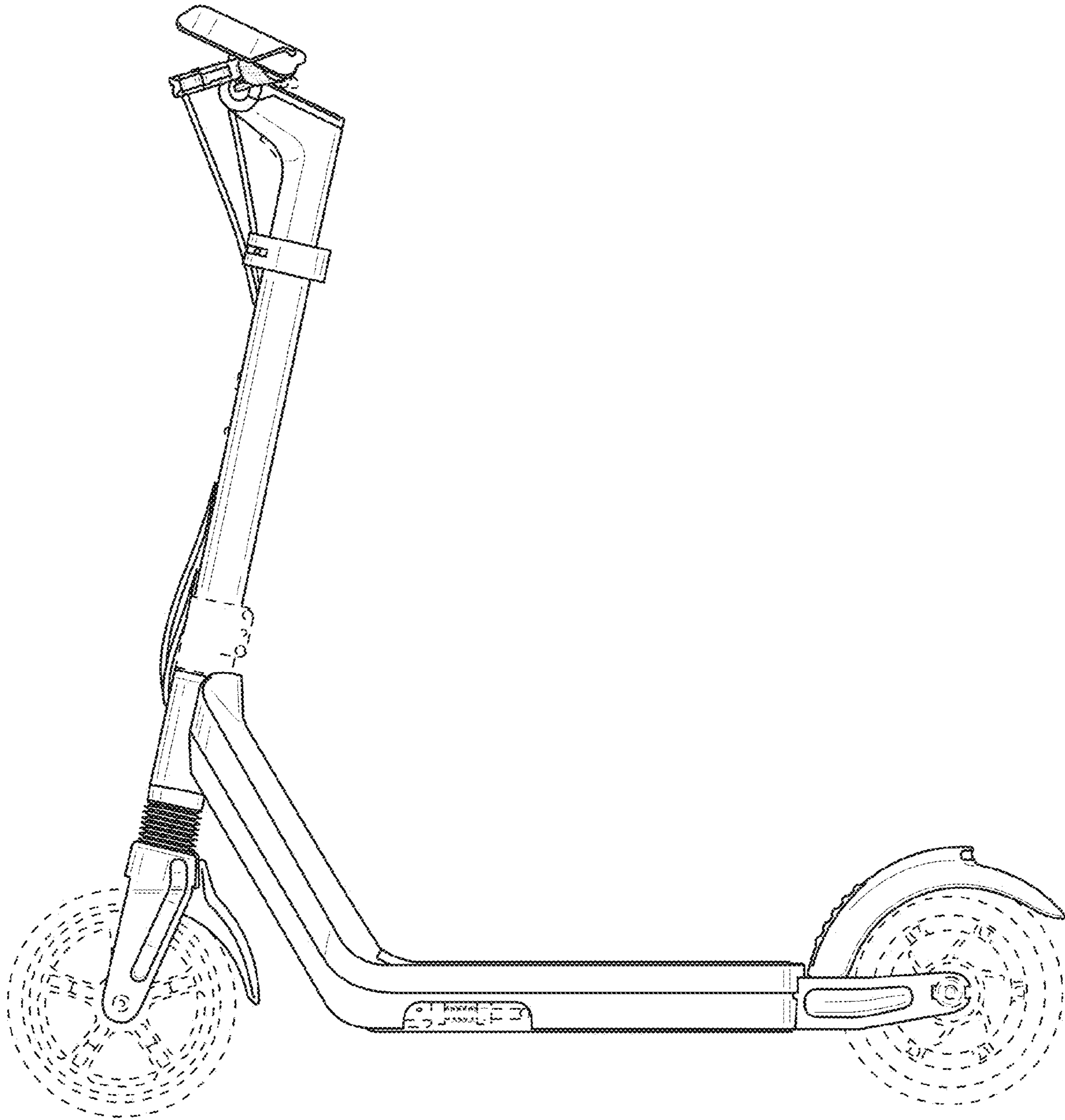

FIG. 4

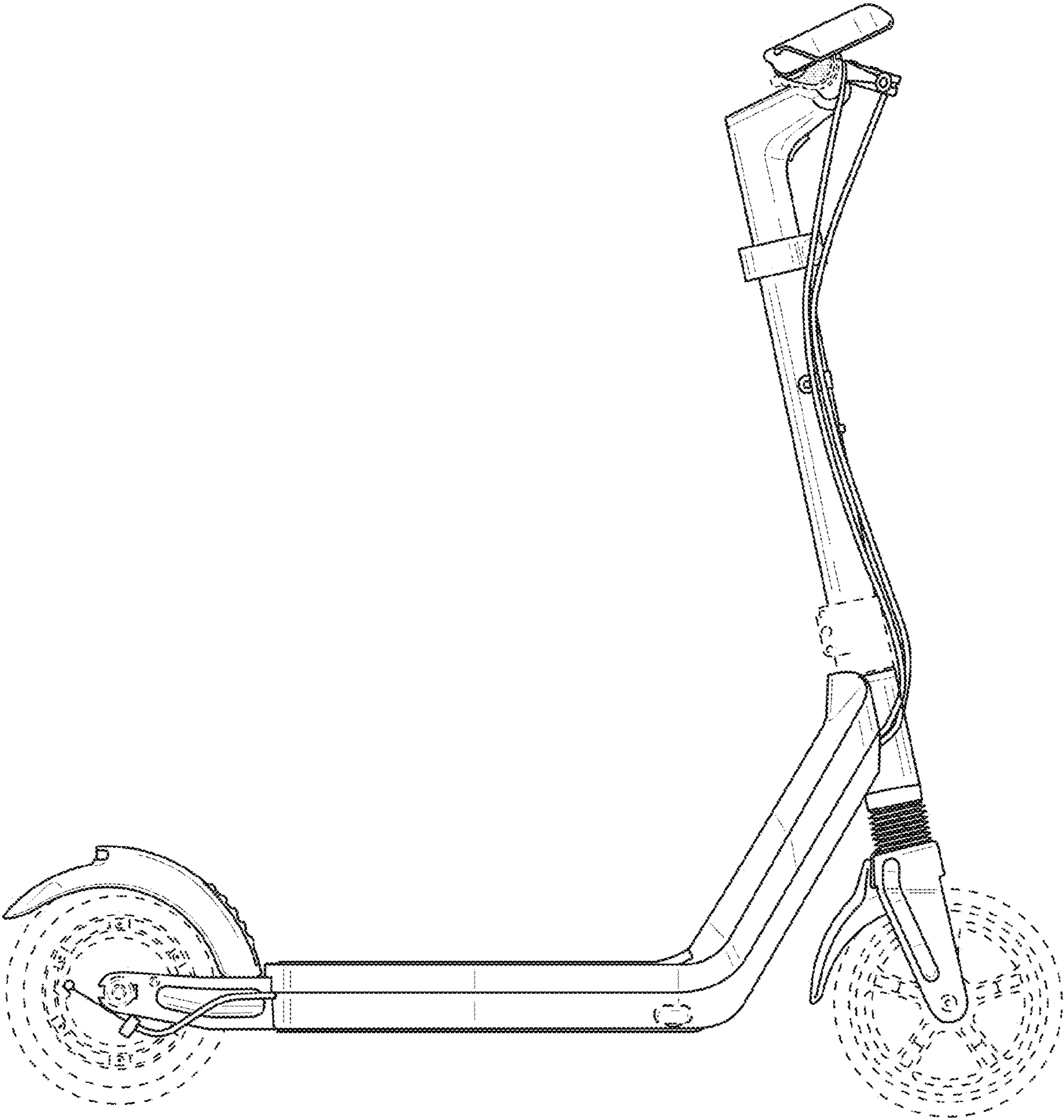

FIG. 5

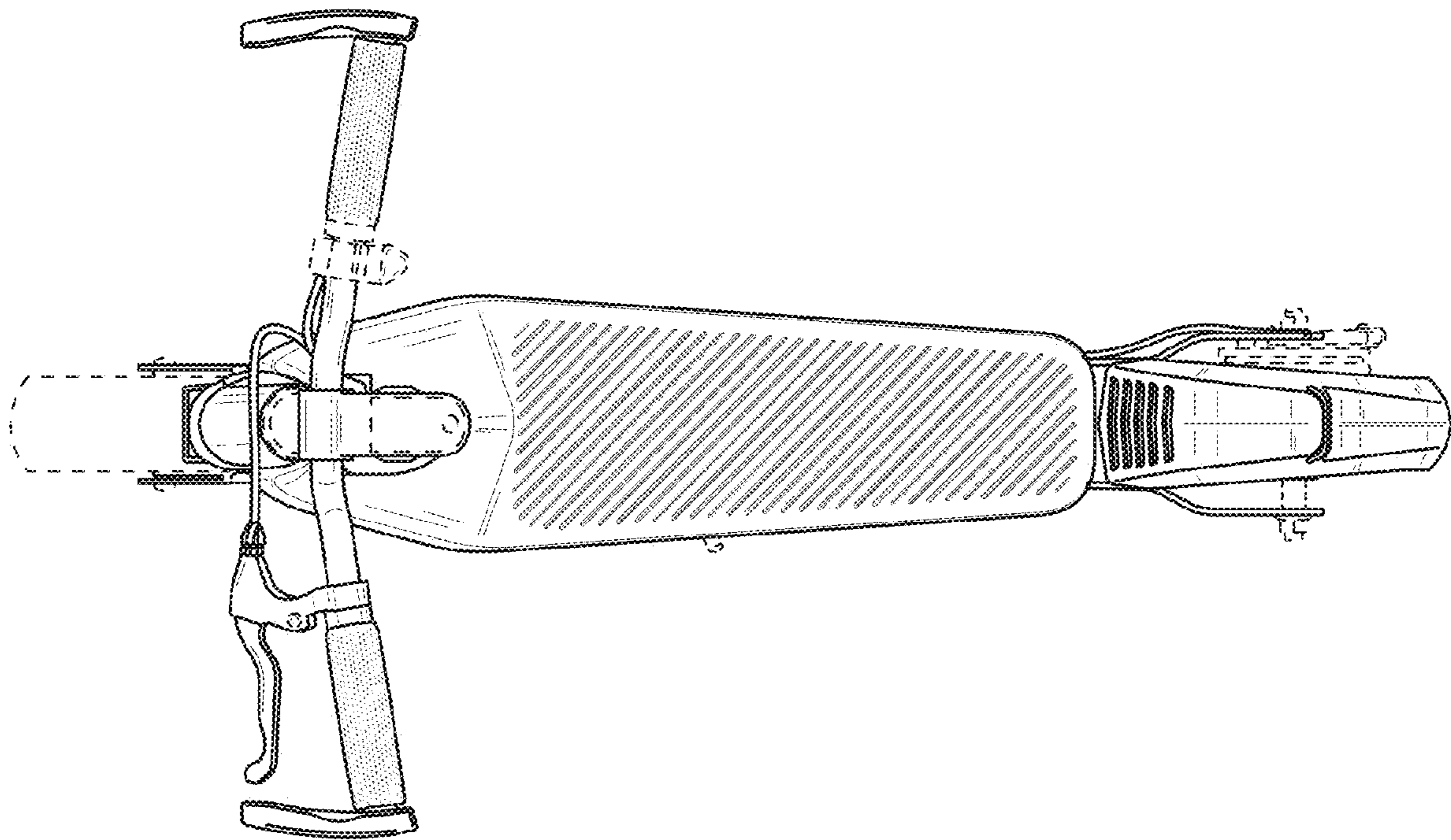

FIG. 6

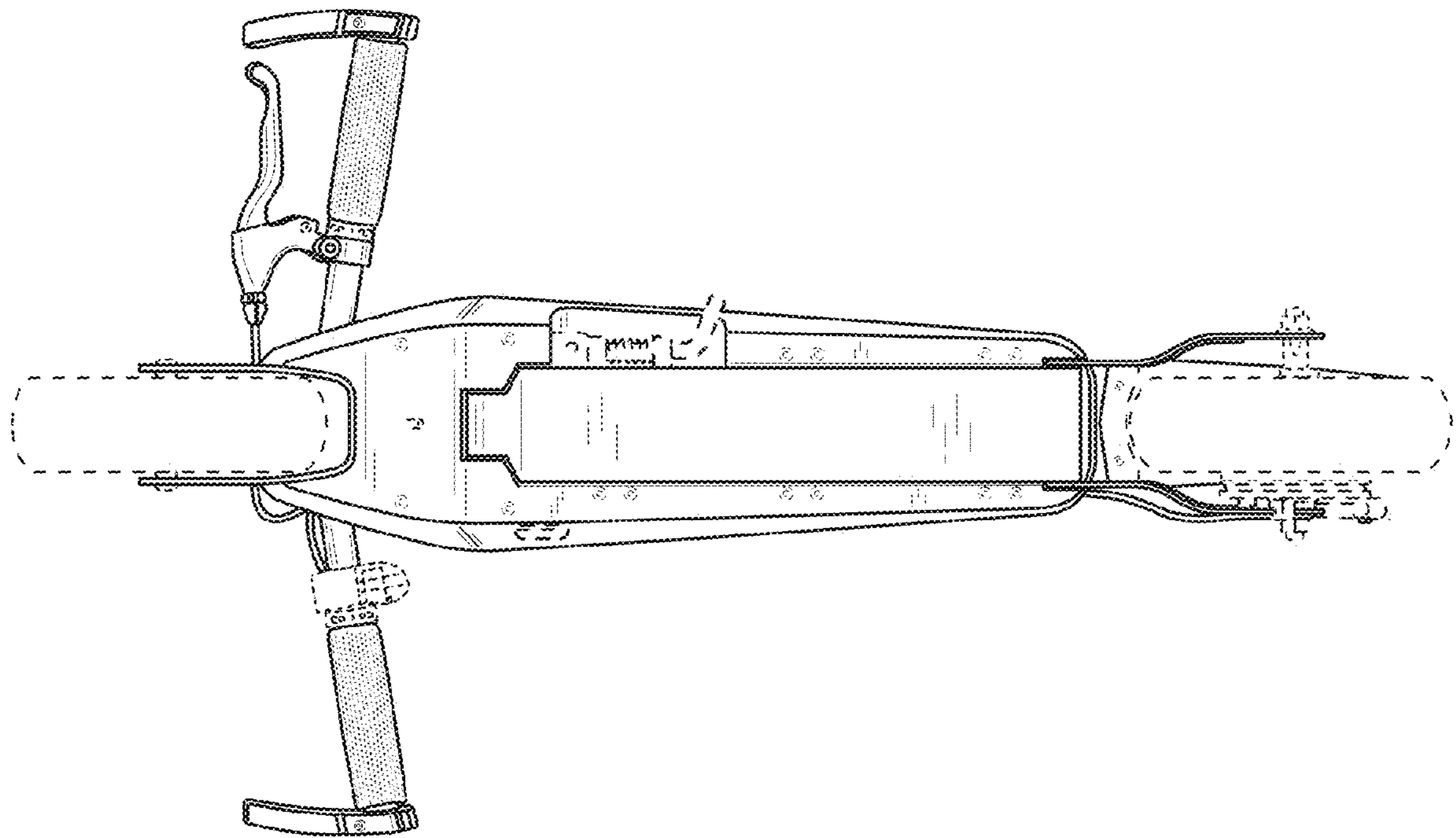

FIG. 7