



US00D976886S

(12) **United States Design Patent** (10) **Patent No.:** **US D976,886 S**  
**Han et al.** (45) **Date of Patent:** **\*\* Jan. 31, 2023**

(54) **ELECTRONIC DEVICE**  
(71) Applicant: **Samsung Electronics Co., Ltd.**,  
Suwon-si (KR)  
(72) Inventors: **Woo-Seung Han**, Suwon-si (KR);  
**Sang-Sik Park**, Suwon-si (KR)  
(73) Assignee: **Samsung Electronics Co., Ltd.**,  
Suwon-si (KR)

D946,547 S \* 3/2022 Kim ..... D14/138 G  
D946,548 S \* 3/2022 Kim ..... D14/138 G  
D949,121 S \* 4/2022 Doi ..... D14/138 G  
D951,897 S \* 5/2022 Ha ..... D14/138 G  
D955,372 S \* 6/2022 Wang ..... D14/248  
D955,373 S \* 6/2022 Wang ..... D14/248  
D958,780 S \* 7/2022 Choi ..... D14/248  
D962,888 S \* 9/2022 Kim ..... D14/138 AC  
D962,927 S \* 9/2022 Song ..... D14/341  
2021/0251083 A1 \* 8/2021 Jung ..... H05K 1/0274

(\*\*) Term: **15 Years**  
(21) Appl. No.: **29/776,178**  
(22) Filed: **Mar. 29, 2021**

(30) **Foreign Application Priority Data**  
Jan. 26, 2021 (KR) ..... 30-2021-0003967  
(51) **LOC (14) Cl.** ..... **14-03**  
(52) **U.S. Cl.**  
USPC ..... **D14/248**  
(58) **Field of Classification Search**  
USPC ..... D14/138 G, 248, 138 C, 138 AB, 341,  
D14/439, 432, 345, 138 R, 138 AA,  
D14/138 AC, 138 AD, 371, 374  
CPC ..... H04M 1/0202; H04M 1/0235; H04M  
1/0237; H04M 1/0239; H04M 1/0266;  
H04M 1/0268; H04M 1/027; H04M  
1/0295; H04M 1/02; H04M 1/0279;  
H04M 1/0283  
See application file for complete search history.

(56) **References Cited**  
U.S. PATENT DOCUMENTS  
D919,589 S \* 5/2021 Ji ..... D14/138 G  
D924,828 S \* 7/2021 Oh ..... D14/138 G  
D930,607 S \* 9/2021 Li ..... D14/138 C  
D940,119 S \* 1/2022 Kim ..... D14/248  
D941,792 S \* 1/2022 Wang ..... D14/248  
D942,437 S \* 2/2022 Wang ..... D14/248

**OTHER PUBLICATIONS**

Samsung Galaxy A32 5G, announced Jan. 13, 2021, [online],  
[retrieved on Sep. 2, 2022]. Retrieved from Internet ,<URL: http://  
www.gsmarena.com>.\*  
Samsung Galaxy A52, announced Mar. 17, 2021, [online], [retrieved  
on Jul. 8, 2022]. Retrieved from Internet ,<URL: http://www.  
gsmarena.com>.\*

\* cited by examiner

*Primary Examiner* — Bridget L Eland  
(74) *Attorney, Agent, or Firm* — NSIP Law

(57) **CLAIM**

We claim the ornamental design for an electronic device, as  
shown and described.

**DESCRIPTION**

FIG. 1 is a front perspective view of an electronic device  
showing our new design;  
FIG. 2 is a front view thereof;  
FIG. 3 is a rear view thereof;  
FIG. 4 is a left-side view thereof;  
FIG. 5 is a right-side view thereof;  
FIG. 6 is a top view thereof;  
FIG. 7 is a bottom view thereof; and,  
FIG. 8 is a rear perspective view thereof.  
The evenly dashed broken lines in the figures depict portions  
of the electronic device which form no part of the claimed  
design.

**1 Claim, 8 Drawing Sheets**

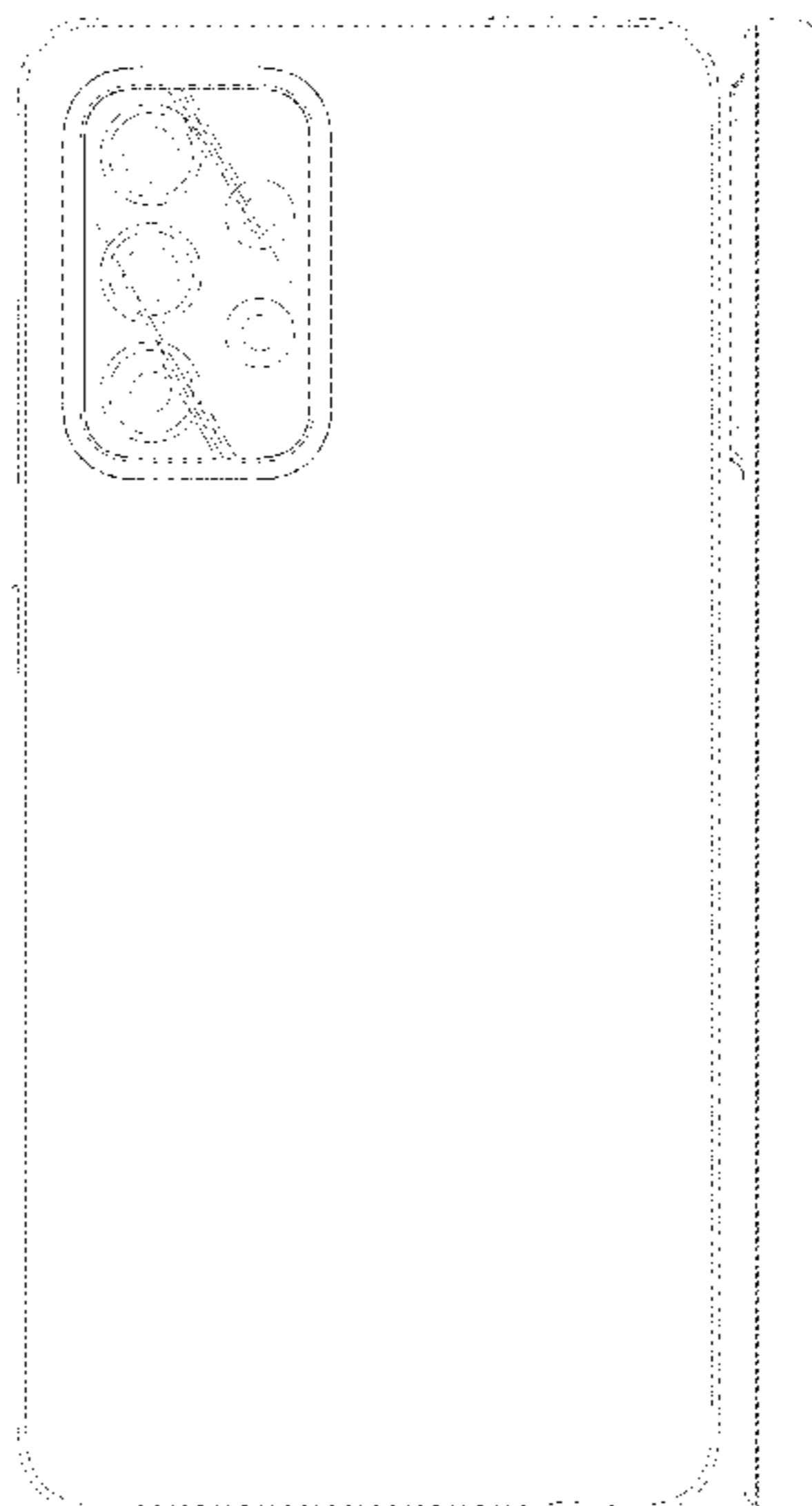

FIG. 1



FIG. 2



FIG. 3

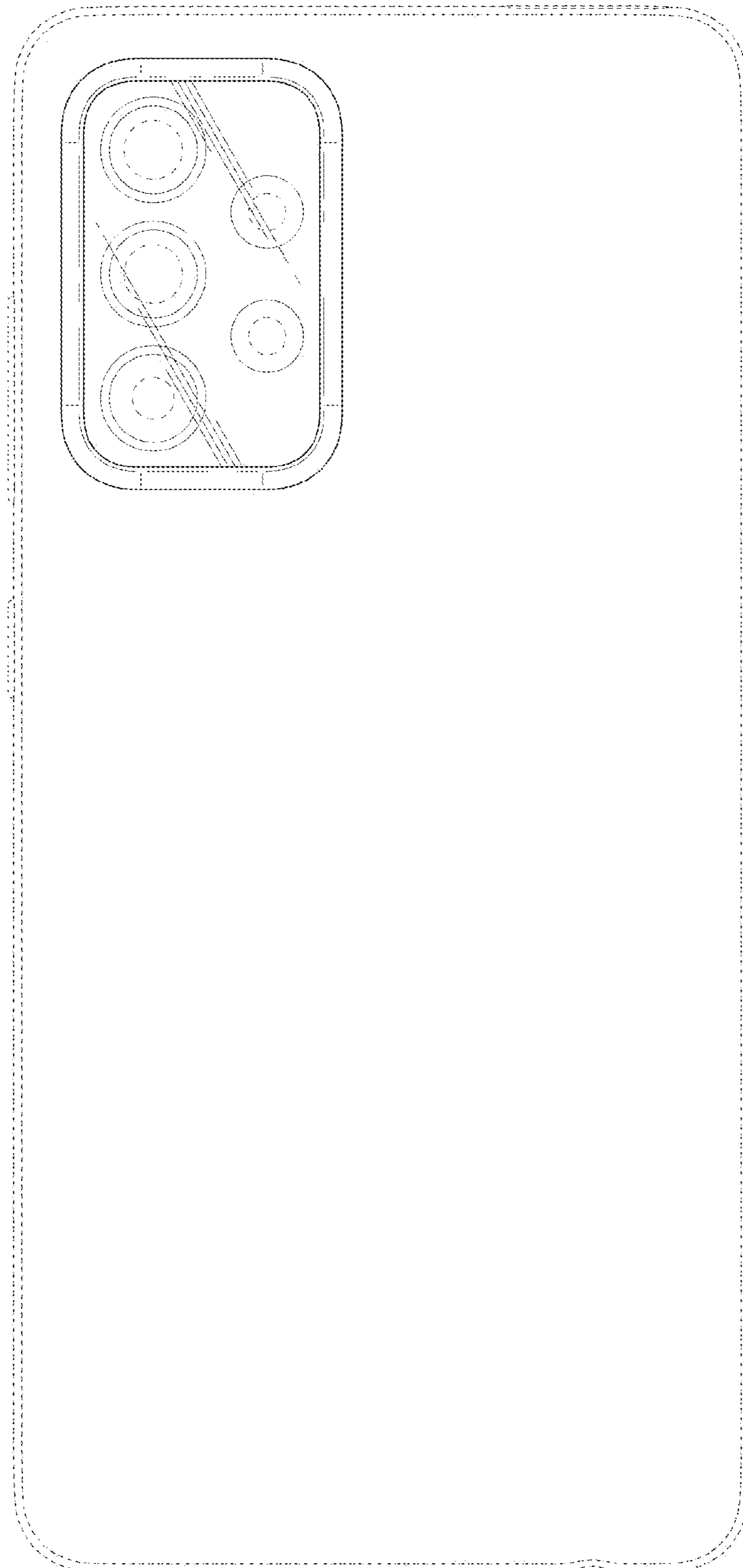

FIG. 4

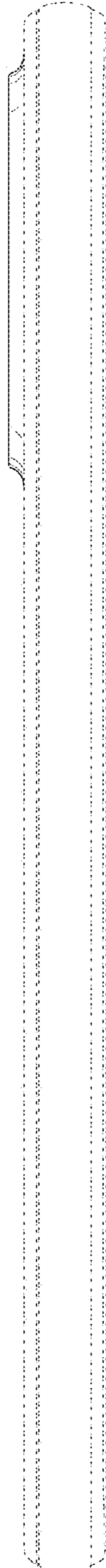

FIG. 5

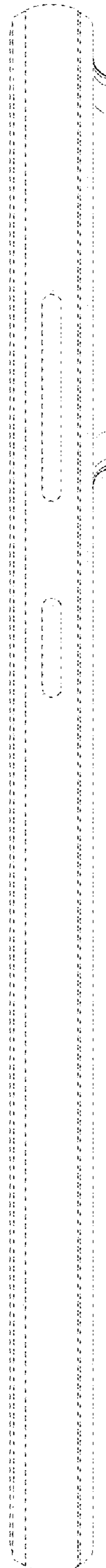

FIG. 6

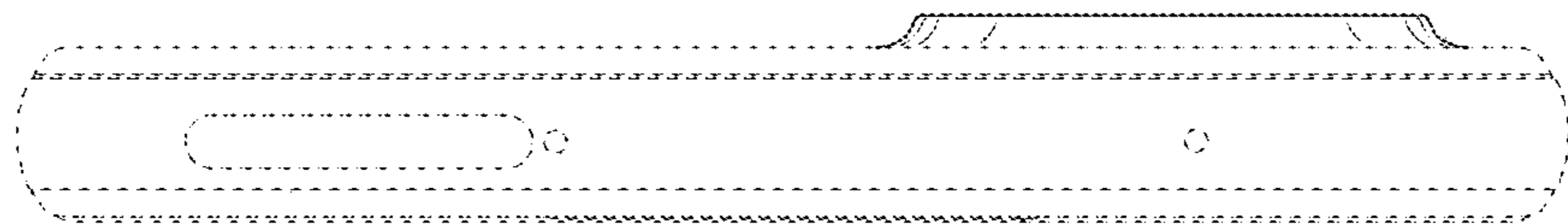

FIG. 7

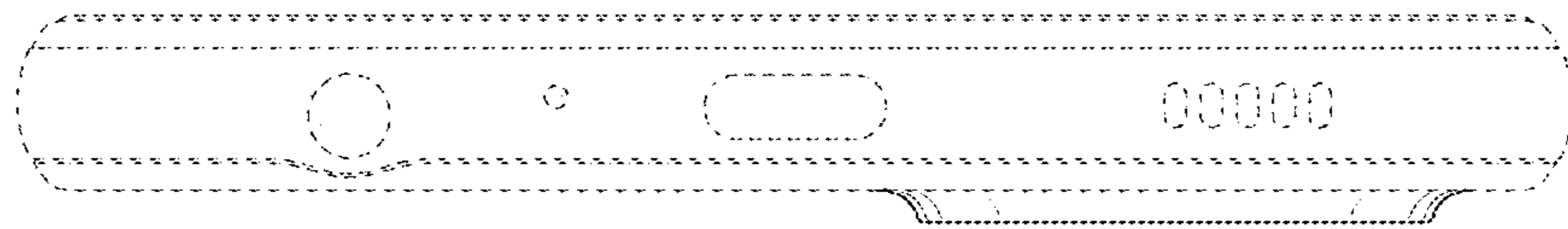



FIG. 8

