



US00D976724S

(12) **United States Design Patent**
Lippert et al.

(10) **Patent No.:** **US D976,724 S**
(45) **Date of Patent:** **** Jan. 31, 2023**

(54) **FLOW ASSEMBLY**

FOREIGN PATENT DOCUMENTS

(71) Applicant: **Endress+Hauser Conducta GmbH+Co. KG**, Gerlingen (DE)

CN 306978037 * 11/2021
EM 000521372-0002 * 5/2006

(Continued)

(72) Inventors: **Holger Lippert**, Leipzig (DE); **Thomas Pfauch**, Leipzig (DE)

OTHER PUBLICATIONS

(73) Assignee: **Endress+Hauser Conducta GmbH+Co. KG**, Gerlingen (DE)

Endress+Hauser, Technical Information Flowfit CCA151, Date first available Oct. 27, 2017, [online]retrieved May 24, 2022, available from https://bdih-prod-assetcentralapi-assetcentral-restsrv.cfapps.eu10.hana.ondemand.com/files/DLA/005056A500261EE7AEDC3E9702C1CE19/TI01357CEN_0117.pdf (Year: 2017).*

(Continued)

(**) Term: **15 Years**

(21) Appl. No.: **29/767,729**

(22) Filed: **Jan. 25, 2021**

(30) **Foreign Application Priority Data**

Jul. 24, 2020 (EM) 008052534-0010

(51) **LOC (14) Cl.** **10-04**

(52) **U.S. Cl.**
USPC **D10/81; D10/96; D23/235**

(58) **Field of Classification Search**
USPC D10/46, 81, 96-103; D23/233-235
CPC G01N 2030/522; G01N 2030/8881; G01N 30/60; G01N 30/6017; G01N 30/38; G01N 30/603; G01N 30/6091; G01N 30/6004; G01N 30/6047; B01D 15/20; B01D 15/18; G01F 15/14; G01F 1/22; G01F 15/185; G01F 15/005; Y10T 137/8158; C02F 1/281; C02F 2201/009; C02F 2305/08; C02F 2201/48; C02F 2303/16; C02F 2101/22; C02F 2101/20; Y02W 10/37; Y02W 10/33; Y02A 20/212
See application file for complete search history.

Primary Examiner — Keli L Hill

Assistant Examiner — Sara S Sahneh

(74) *Attorney, Agent, or Firm* — Mark A. Logan;
Endress+Hauser (USA) Holding, Inc.

(57) **CLAIM**

The ornamental design for a flow assembly, as shown and described.

DESCRIPTION

FIG. 1 is an isometric view of a flow assembly; FIG. 2 is a front view of the flow assembly of FIG. 1; FIG. 3 is a right side view of the flow assembly of FIG. 1; FIG. 4 is a left side view of the flow assembly of FIG. 1; FIG. 5 is a top view of the flow assembly of FIG. 1; FIG. 6 is a bottom view of the flow assembly of FIG. 1; and, FIG. 7 is a rear view of the flow assembly of FIG. 1. The broken lines shown are included for the purpose of illustrating portions of the flow assembly that form no part of the claimed design.

(56) **References Cited**

U.S. PATENT DOCUMENTS

D376,549 S * 12/1996 Stimpfig D10/96
6,171,486 B1 * 1/2001 Green G01N 30/6091
210/656

(Continued)

1 Claim, 7 Drawing Sheets

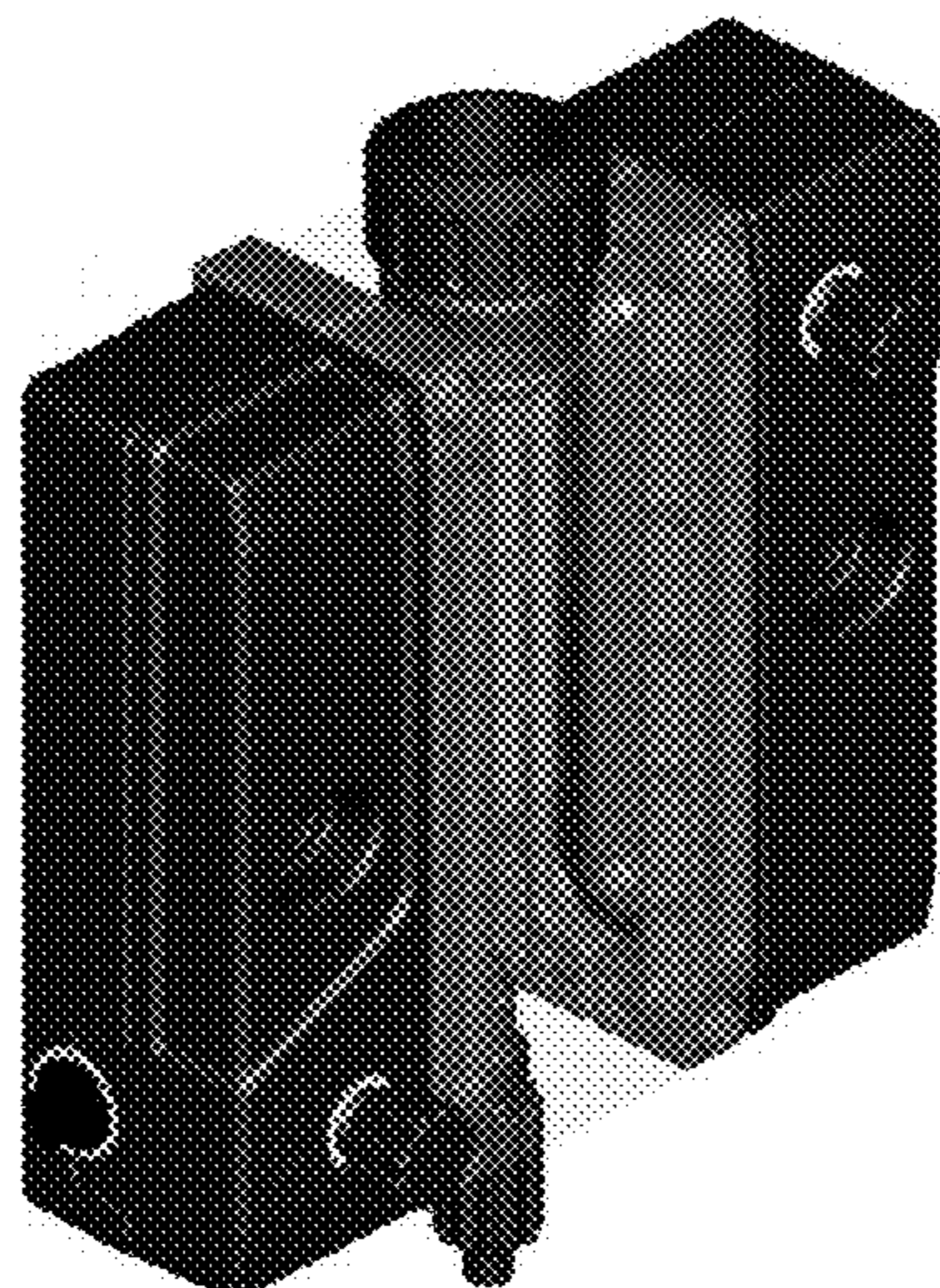

(56)

References Cited

U.S. PATENT DOCUMENTS

8,336,375 B2 * 12/2012 Thai G01F 15/14
73/199
D712,769 S * 9/2014 Betsinger D10/101
9,844,741 B2 * 12/2017 Raedts G01N 30/60
D828,195 S * 9/2018 Tschudin D10/96
10,266,431 B2 * 4/2019 Jo C22C 9/04
10,471,404 B2 * 11/2019 Andreis F16K 31/02
10,684,268 B2 * 6/2020 Surman G01N 33/2823
D913,828 S * 3/2021 Kurisaki D23/235
D914,524 S * 3/2021 Kurisaki D23/235
D929,543 S * 8/2021 Okawara D23/233
D941,690 S * 1/2022 Frazee D10/99
2022/0323887 A1 * 10/2022 Grimm C02F 1/001

FOREIGN PATENT DOCUMENTS

EM 008052534-0009 * 7/2020
EM 008597470-0001 * 6/2021
JP D1091806 * 9/1999

OTHER PUBLICATIONS

Endress+Hauser, Technical Information Flowfit CCA250, Date first available Jul. 3, 2009, [online]retrieved May 24, 2022, available from https://bdih-prod-assetcentralapi-assetcentral-rest-srv.cfapps.eu10.hana.ondemand.com/files/DLA/4A8A5338500D45F4E10000000A35E042/TI062CEN_0709.pdf (Year: 2009).*

Endress+Hauser, Technical Information Flowfit CYA27, Date first available Nov. 23, 2020, [online]retrieved May 24, 2022, available from https://bdih-prod-assetcentralapi-assetcentral-rest-srv.cfapps.eu10.hana.ondemand.com/files/DLA/005056A500261EDB8BC8C721CA57C9DC/TI01559CEN_0120.pdf (Year: 2020).*

Endress+Hauser, Installation Instructions KitCxA O-ring, Date first available Mar. 18, 2021, [online]retrieved May 24, 2022, available from https://bdih-prod-assetcentralapi-assetcentral-rest-srv.cfapps.eu10.hana.ondemand.com/files/DLA/005056A500261EEBAEBFCCE2C1E81029/EA01355CEN_0121.pdf (Year: 2021).*

* cited by examiner

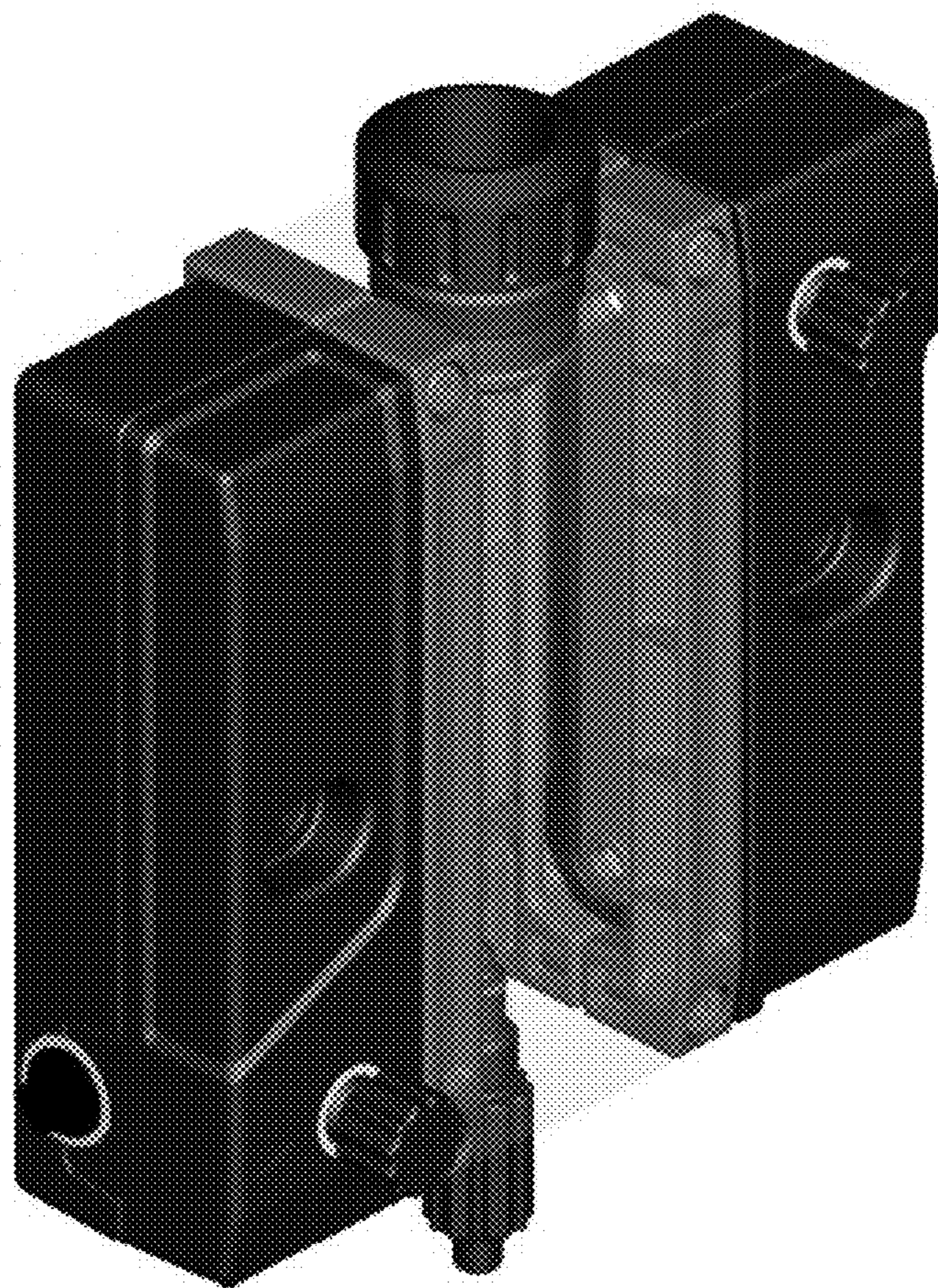

FIG. 1

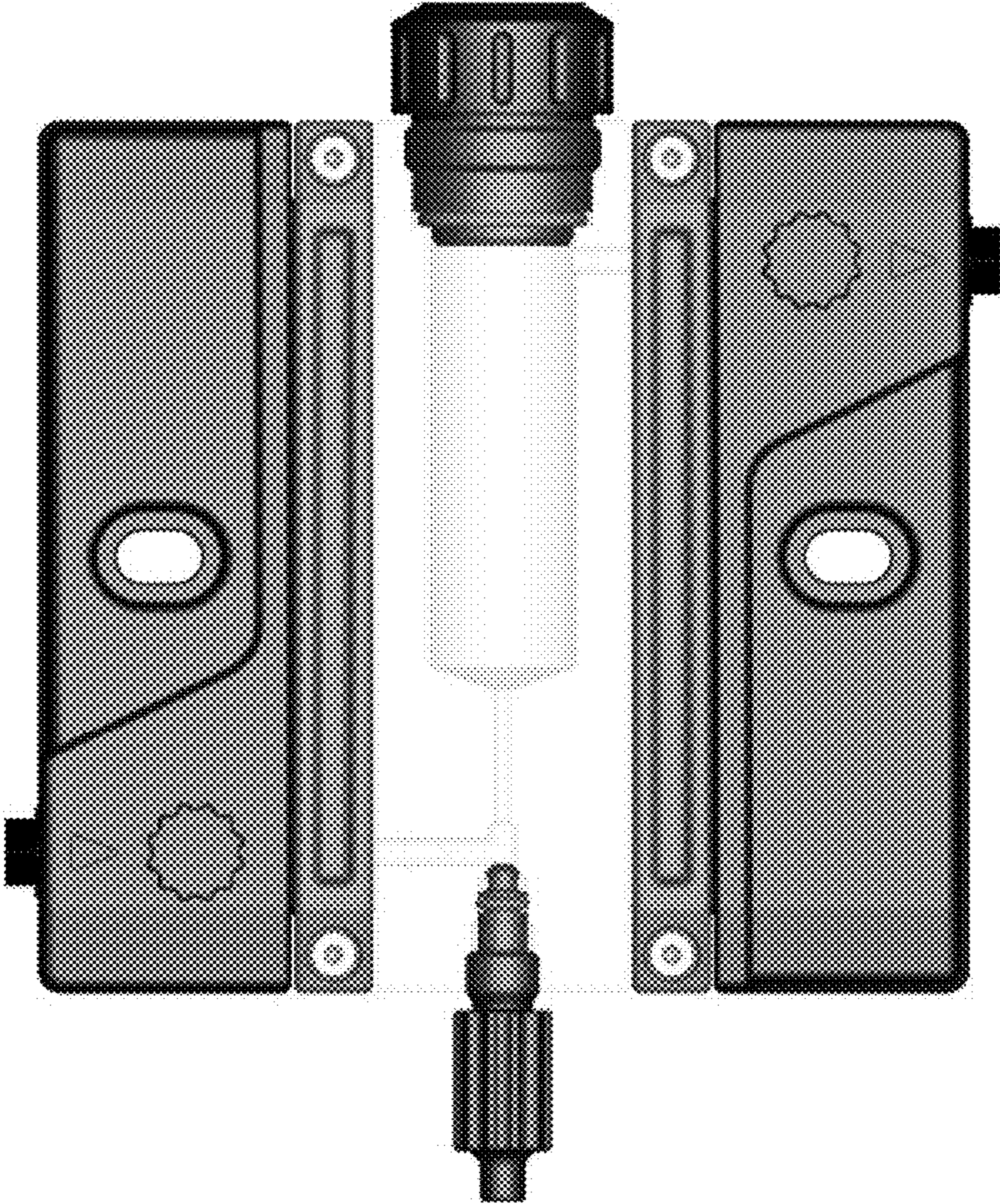

FIG. 2

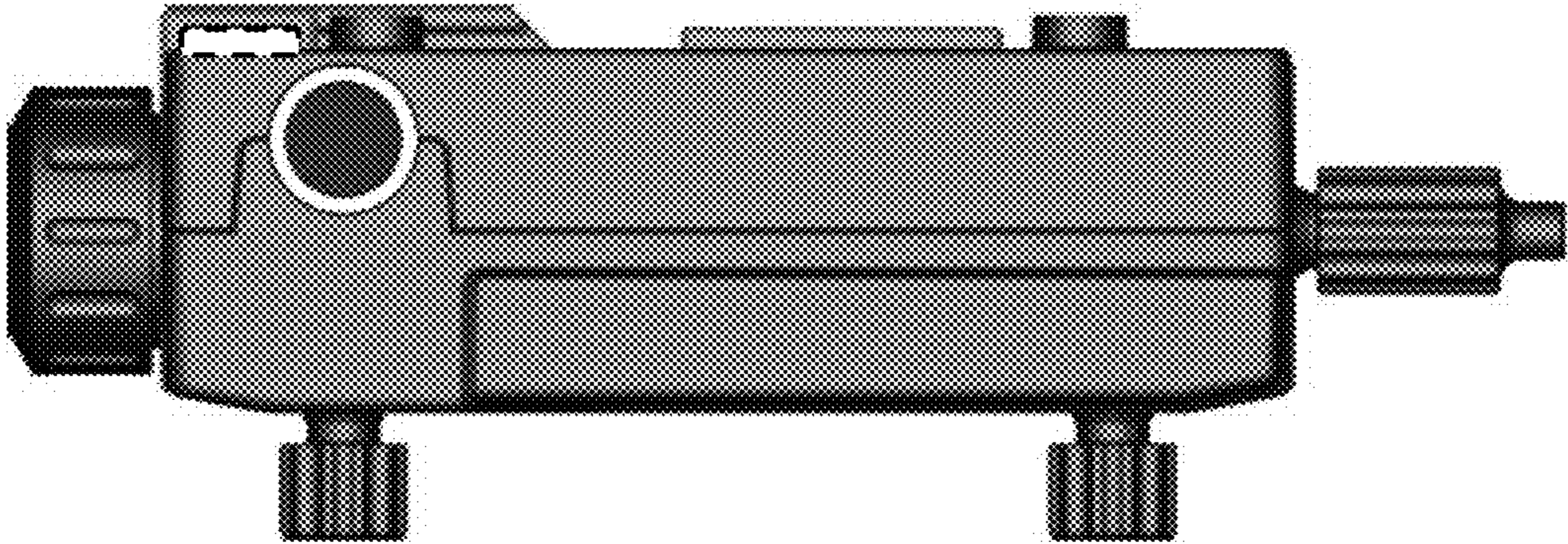

FIG. 3

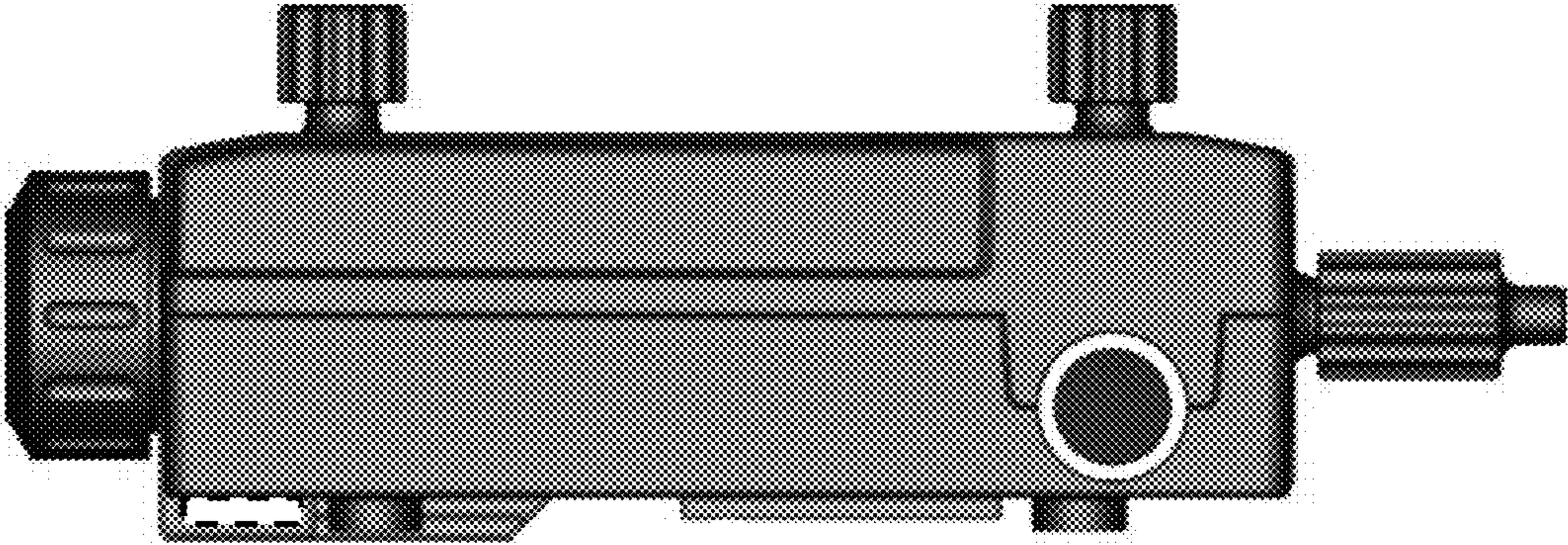

FIG. 4

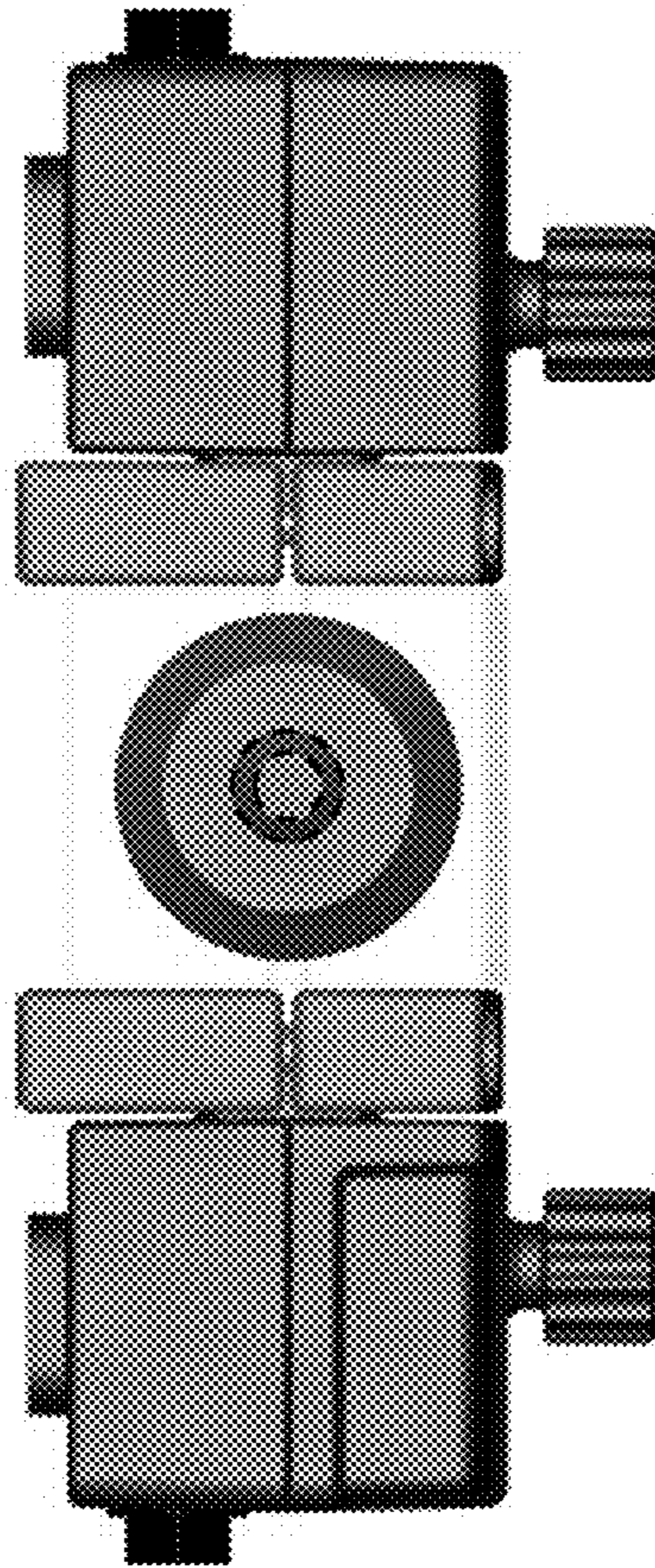

FIG. 5

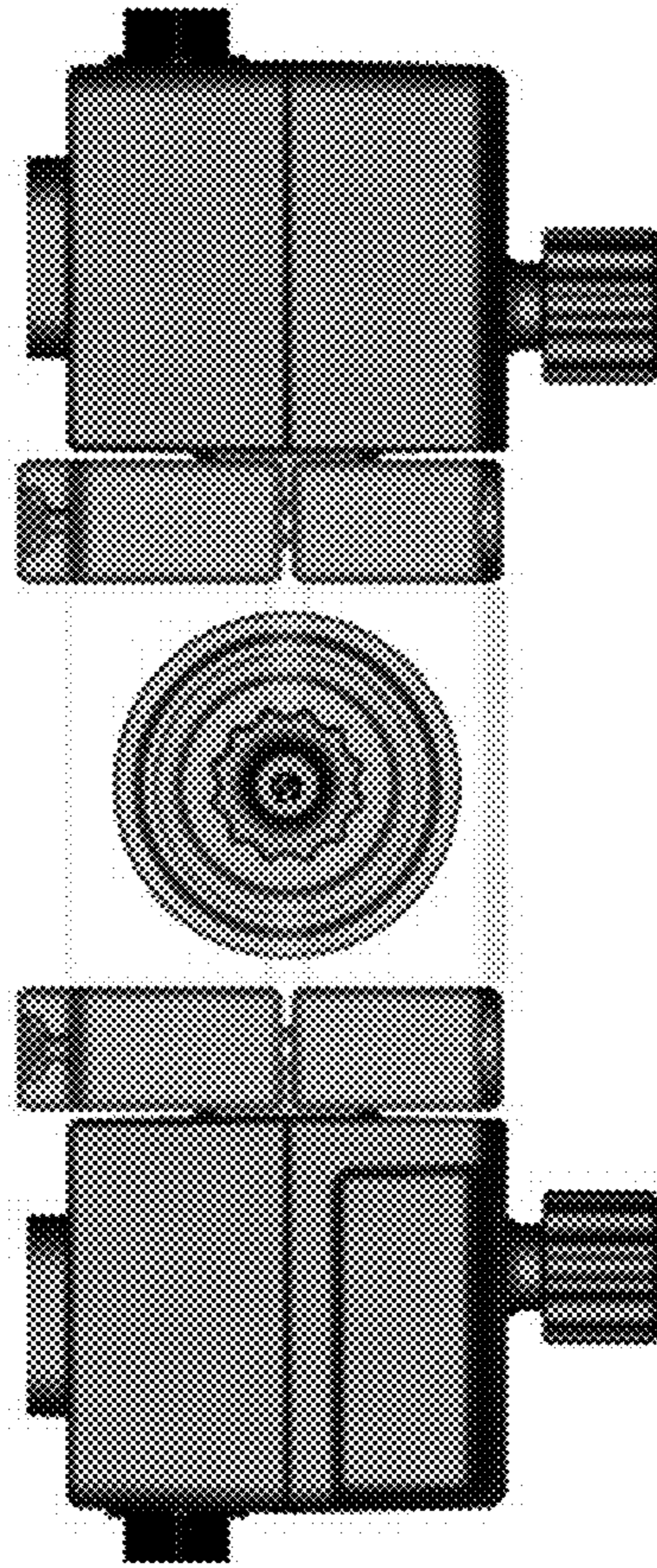

FIG. 6

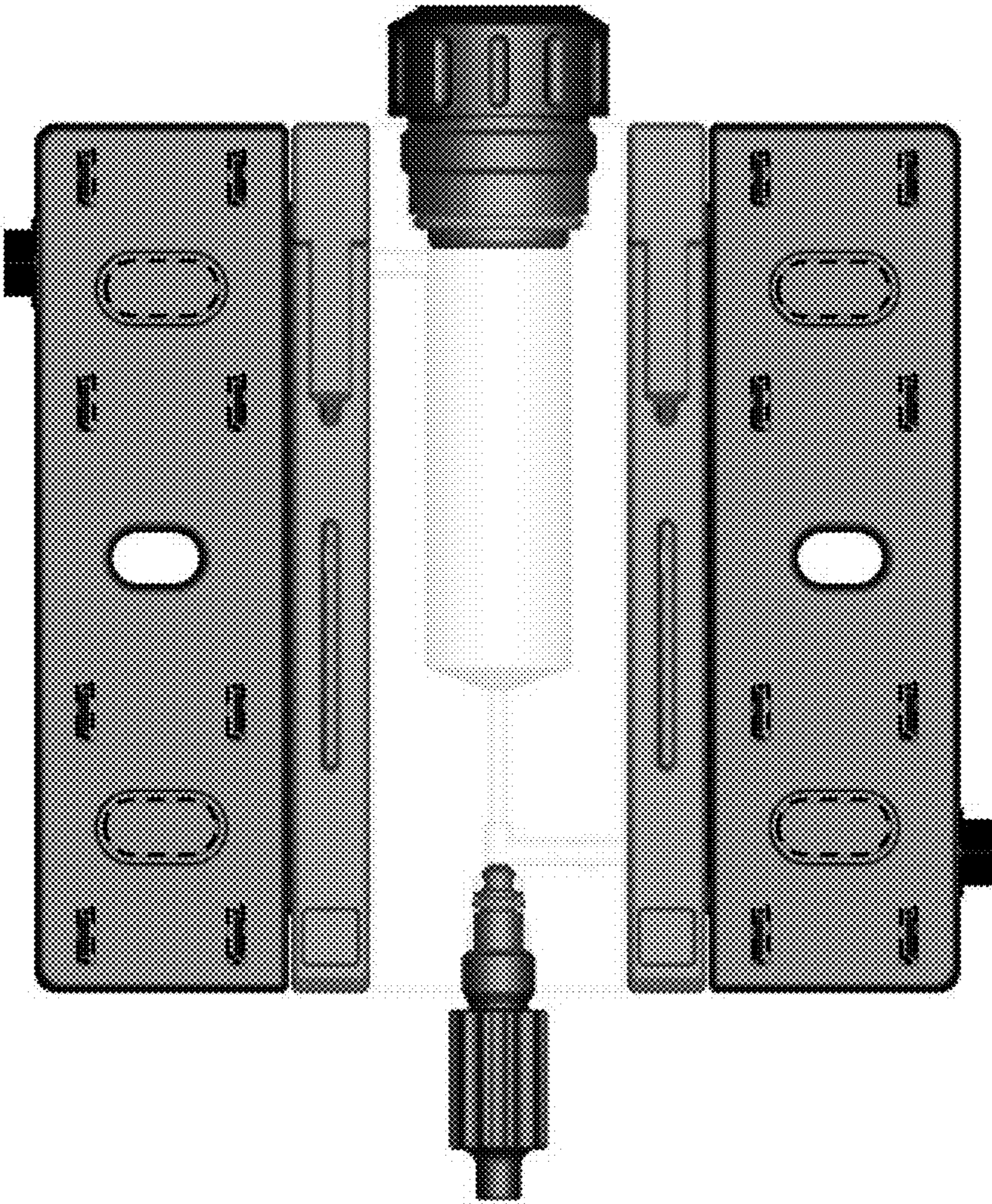

FIG. 7