



US00D976515S

(12) **United States Design Patent**  
**Liang**

(10) **Patent No.:** **US D976,515 S**

(45) **Date of Patent:** **\*\* Jan. 24, 2023**

(54) **HYDRAULIC JACK**

(71) Applicant: **Weifeng Liang**, Guangzhou (CN)

(72) Inventor: **Weifeng Liang**, Guangzhou (CN)

(\*\*) Term: **15 Years**

(21) Appl. No.: **29/737,521**

(22) Filed: **Jun. 10, 2020**

(51) **LOC (14) Cl.** ..... **12-05**

(52) **U.S. Cl.**  
USPC ..... **D34/31**

(58) **Field of Classification Search**  
USPC ..... D34/31; D12/106  
CPC ..... B60S 9/12; B60S 9/06; B60S 9/02; B66F  
3/24; B66F 3/28; B66F 3/247; B66F  
3/25; B66F 3/30; B66F 3/12; B66F 3/18;  
B66F 5/00; B66F 5/04; B66F 9/06; B66F  
9/00; B66F 7/00; B66F 7/02; B66F 3/38  
See application file for complete search history.

D579,167 S *	10/2008	Lin	.....	F16F 1/127 D34/31
D582,623 S *	12/2008	Qian	.....	D34/31
D823,569 S *	7/2018	Fox	.....	D34/31
D828,972 S *	9/2018	Wu	.....	D34/31
D842,578 S *	3/2019	Brown	.....	D34/31
2007/0284501 A1 *	12/2007	Liu	.....	F16F 1/127 248/352
2011/0062401 A1 *	3/2011	Shen	.....	B66F 5/04 254/93 R
2011/0167566 A1 *	7/2011	Lee	.....	B66F 5/00 7/100
2011/0227014 A1 *	9/2011	Lautzenhiser	.....	B66F 3/42 254/93 H
2012/0187004 A1 *	7/2012	Kania	.....	B66F 5/04 206/216
2014/0158962 A1 *	6/2014	Lautzenhiser	.....	B66F 3/42 254/93 H
2015/0123051 A1 *	5/2015	Arzouman	.....	B66F 1/08 254/133 R

\* cited by examiner

*Primary Examiner* — Cynthia Ramirez

(74) *Attorney, Agent, or Firm* — Justin Lampel

(56) **References Cited**

U.S. PATENT DOCUMENTS

4,635,902 A *	1/1987	Chou	.....	B66F 3/30 254/8 B
D296,598 S *	7/1988	Hung	.....	B66F 3/30 D34/31
D332,337 S *	1/1993	Wang	.....	B66F 5/00 D34/31
D358,923 S *	5/1995	Hawkins	.....	B66F 5/04 D34/31
6,000,681 A *	12/1999	Hussaini	.....	B66F 3/38 254/133 R
D453,983 S *	2/2002	Lin	.....	B66F 3/38 D34/31
6,357,724 B1 *	3/2002	Hung	.....	B66F 5/00 254/93 H
D563,623 S *	3/2008	Hernandez	.....	B66F 1/08 D34/31

(57) **CLAIM**

The ornamental design for a hydraulic jack, as shown and described.

**DESCRIPTION**

FIG. 1 is a perspective view of a hydraulic jack showing the claimed design;  
FIG. 2 is a top plan view thereof;  
FIG. 3 is a left side view thereof;  
FIG. 4 is a front elevational view thereof;  
FIG. 5 is a right side view thereof;  
FIG. 6 is a rear elevational view thereof; and,  
FIG. 7 is a bottom plan view thereof.

**1 Claim, 7 Drawing Sheets**

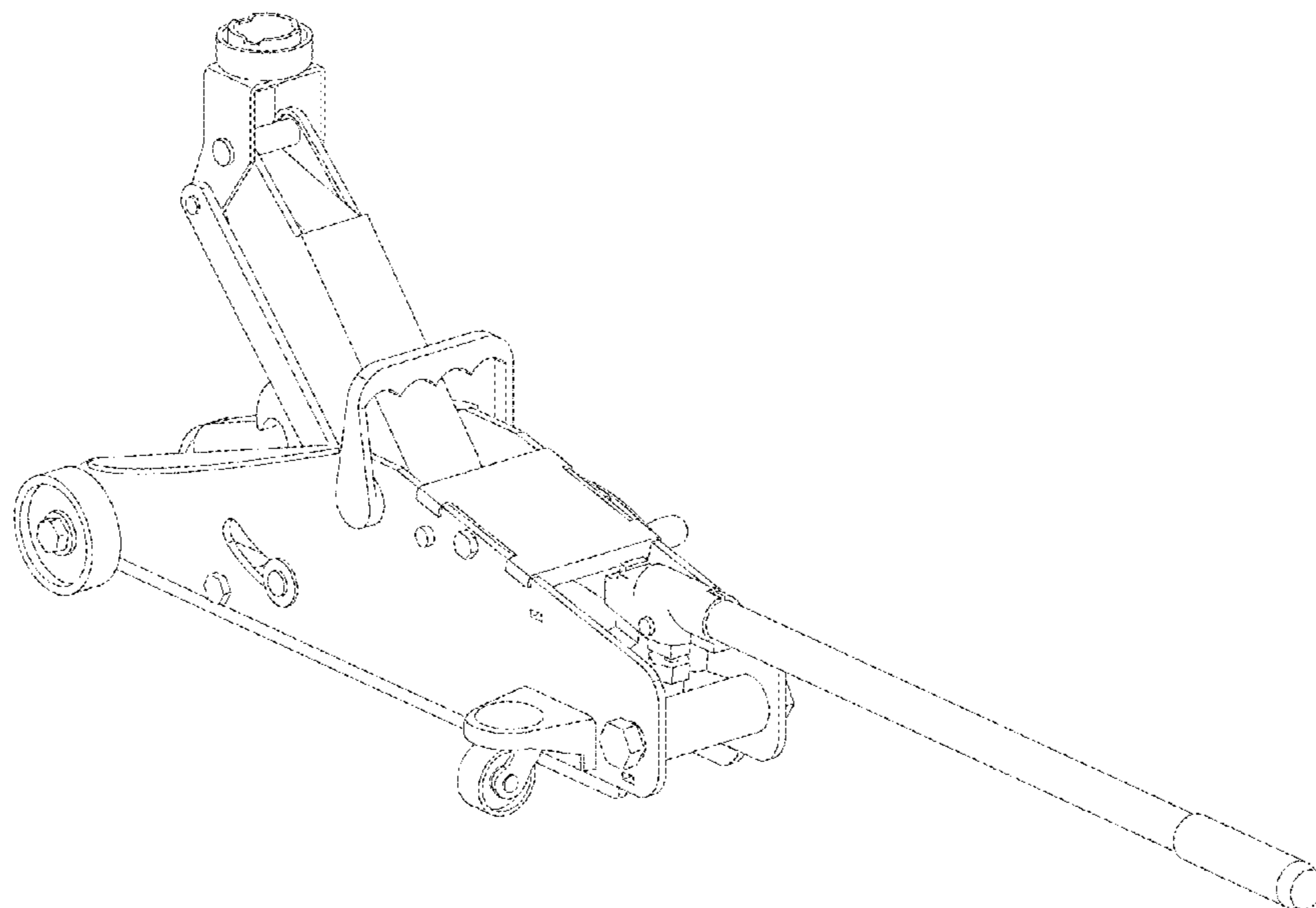

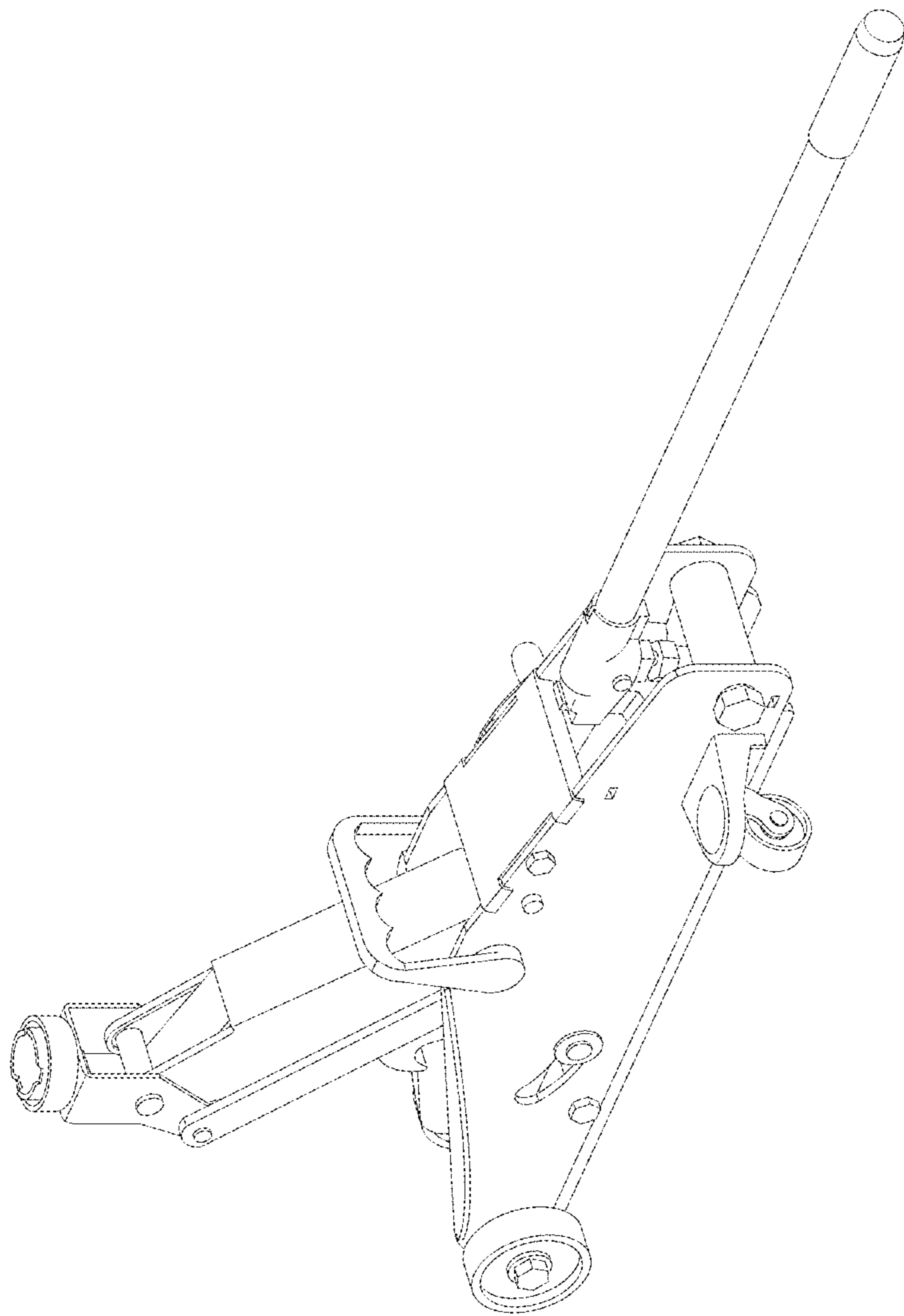

FIG.1

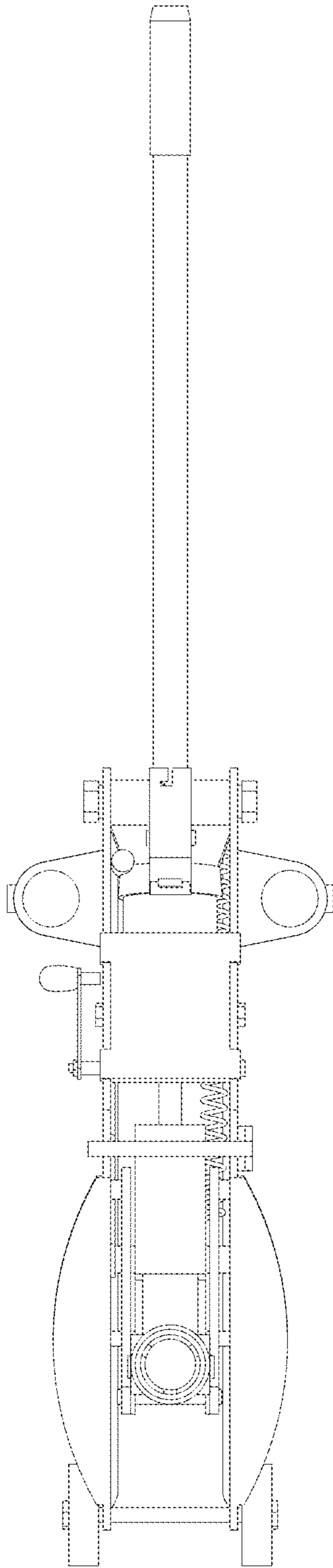

FIG. 2

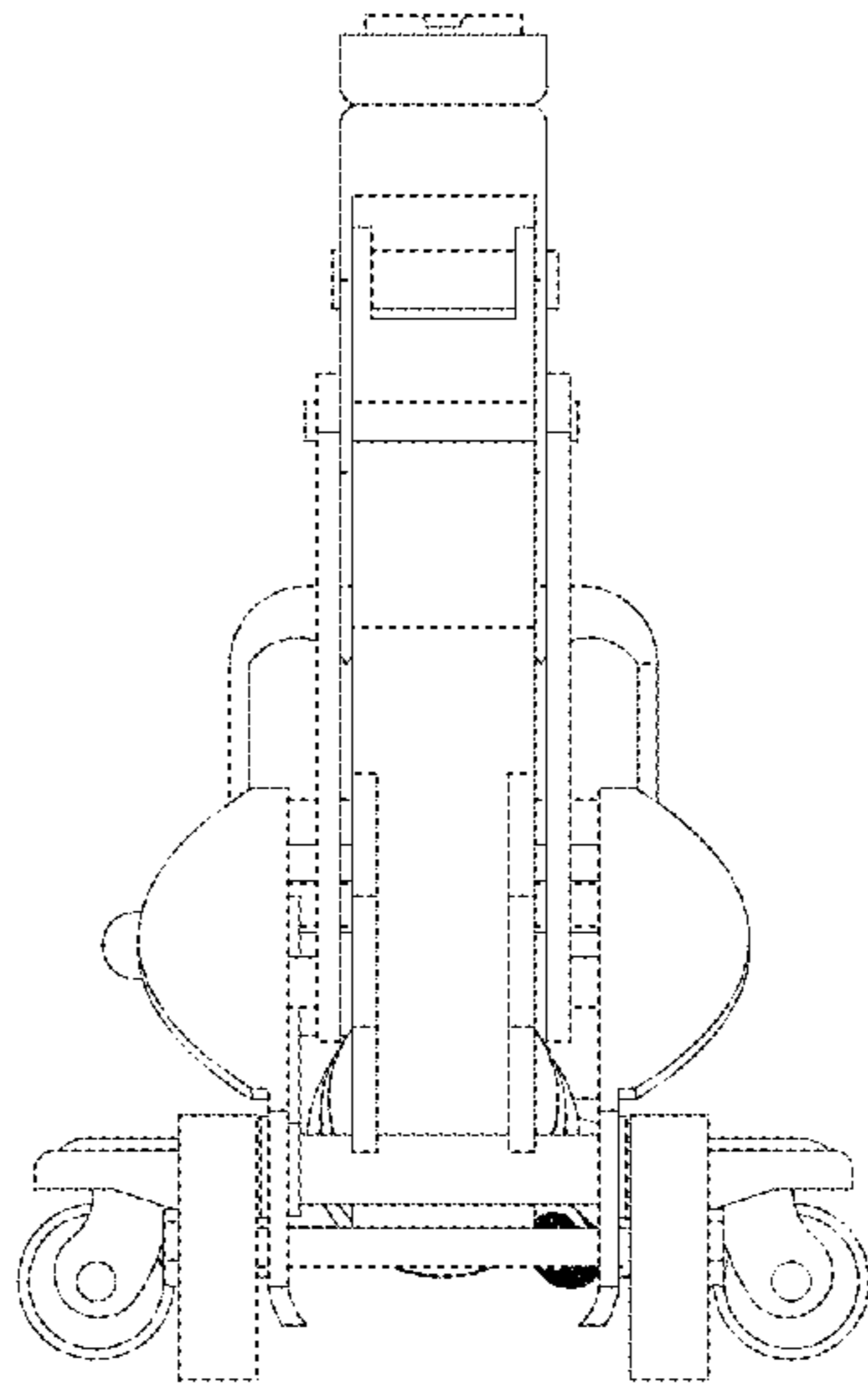

FIG.3

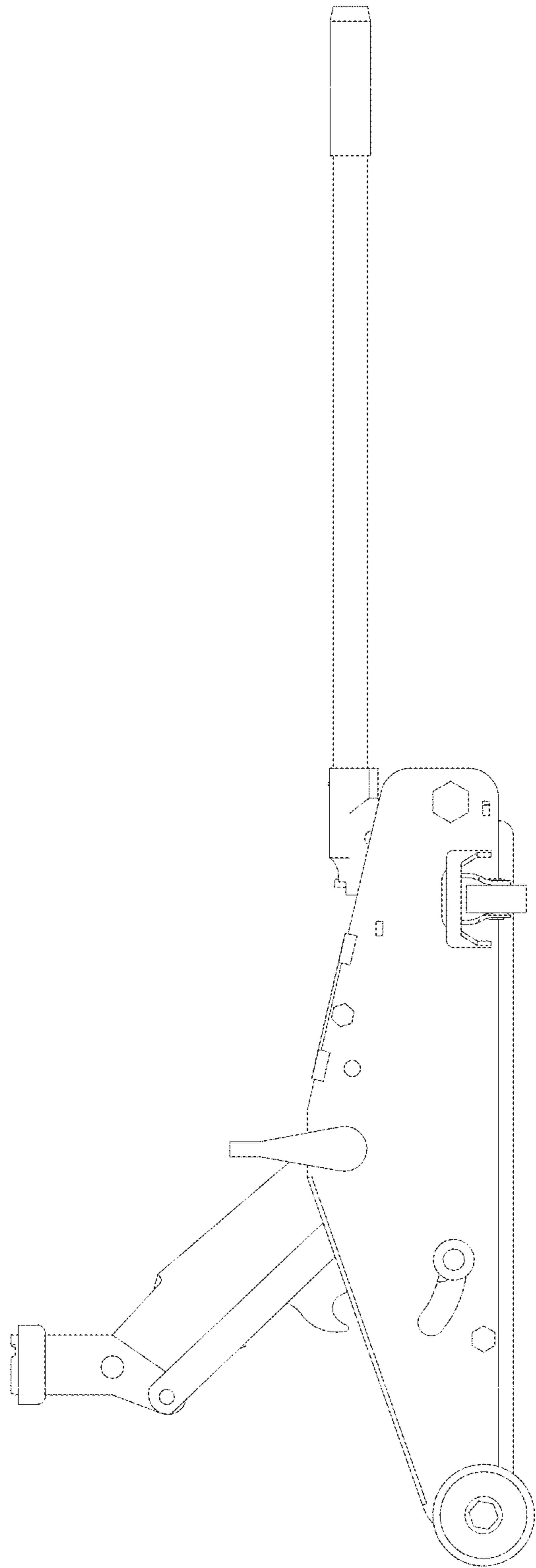

FIG. 4

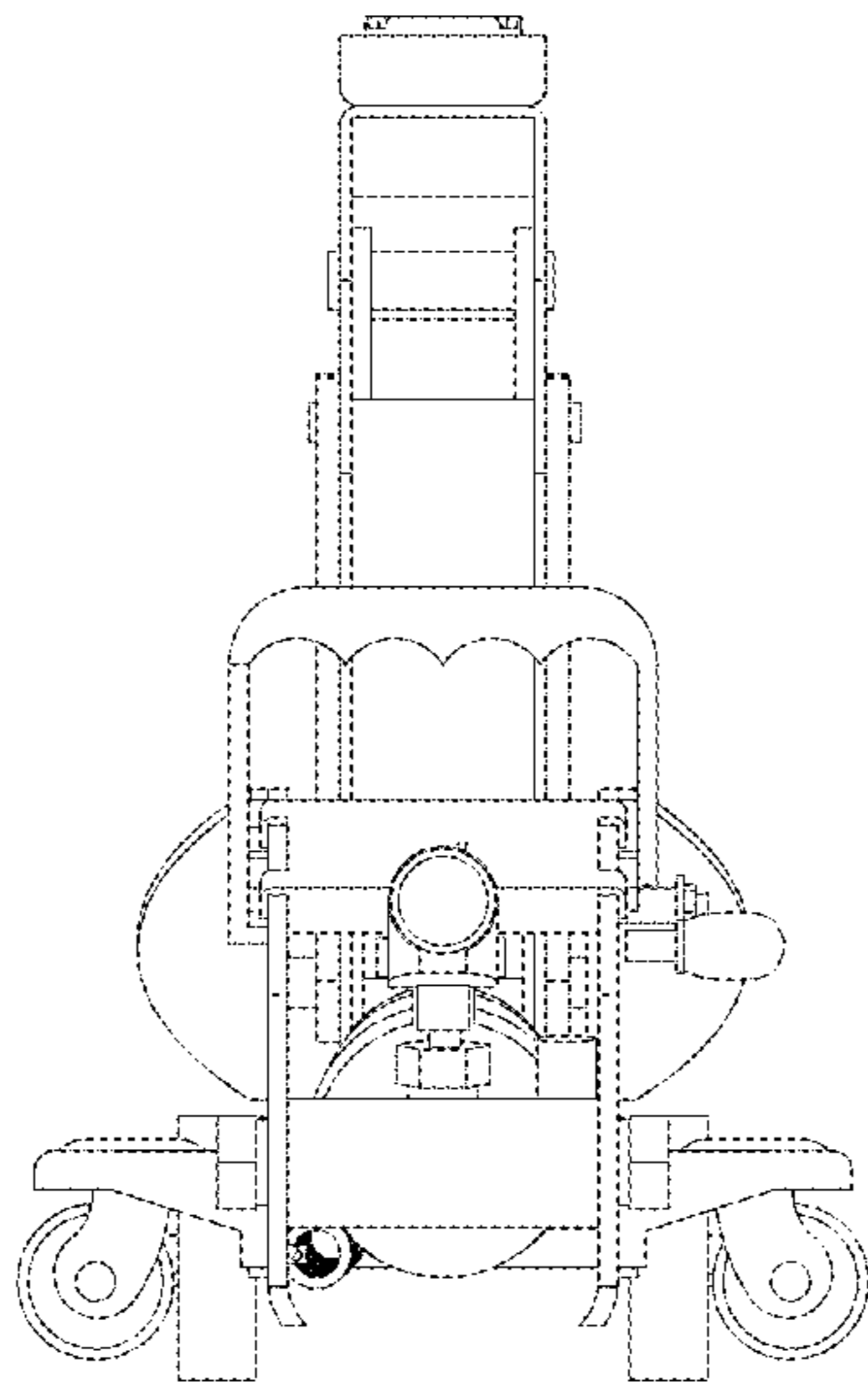

FIG. 5

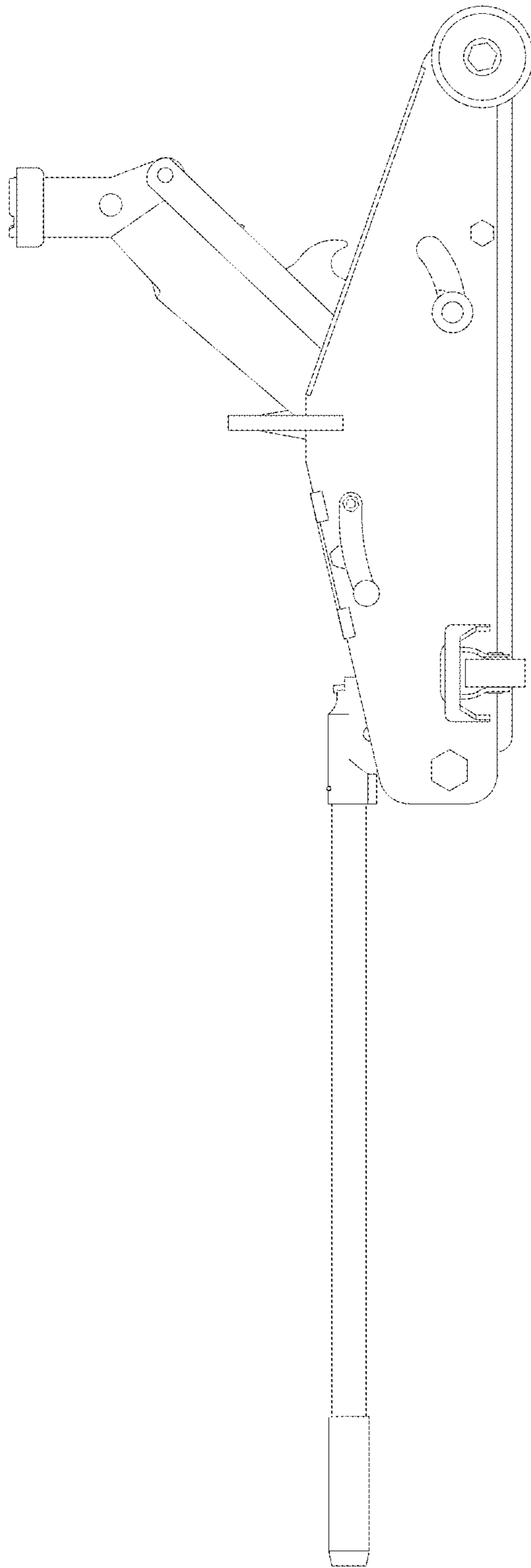

FIG. 6

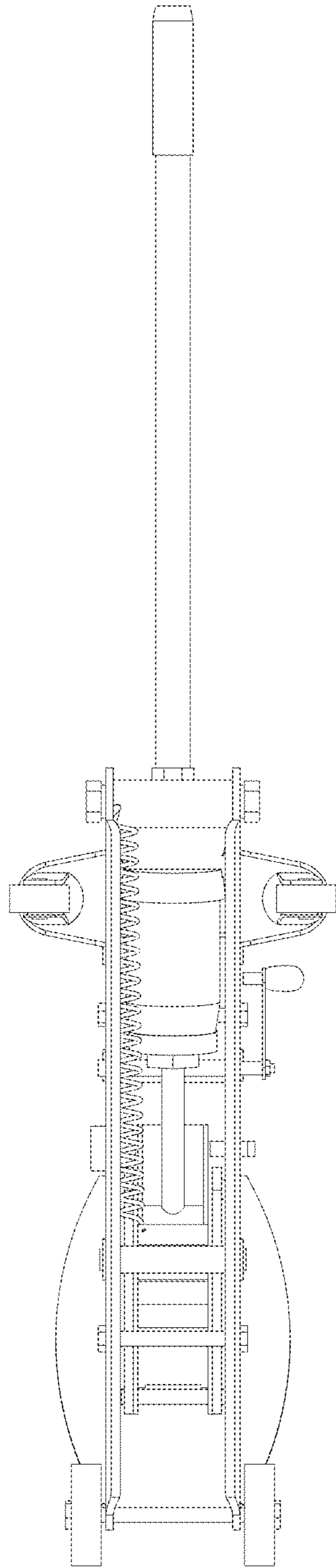

FIG. 7