



US00D976129S

(12) **United States Design Patent** (10) **Patent No.:** **US D976,129 S**  
**Akao et al.** (45) **Date of Patent:** **\*\* Jan. 24, 2023**

(54) **TEMPERATURE SENSOR**

**DESCRIPTION**

(71) Applicant: **KOKUSAI ELECTRIC CORPORATION**, Tokyo (JP)  
(72) Inventors: **Tokunobu Akao**, Toyama (JP); **Tetsuya Kosugi**, Toyama (JP)  
(73) Assignee: **KOKUSAI ELECTRIC CORPORATION**, Tokyo (JP)

(\*\*) Term: **15 Years**

(21) Appl. No.: **29/773,791**

(22) Filed: **Mar. 11, 2021**

(30) **Foreign Application Priority Data**

Sep. 15, 2020 (JP) ..... 2020019645 D

(51) **LOC (14) Cl.** ..... **10-04**

(52) **U.S. Cl.**  
USPC ..... **D10/60**

(58) **Field of Classification Search**  
USPC ..... D10/49, 50, 51, 52, 53, 54, 55, 56, 60  
(Continued)

(56) **References Cited**

**U.S. PATENT DOCUMENTS**

9,488,528 B2 \* 11/2016 Schlipf ..... G01K 7/02  
D780,606 S 3/2017 Osaka et al.  
(Continued)

**FOREIGN PATENT DOCUMENTS**

JP 1534939 S 10/2015

*Primary Examiner* — Antoine Duval Davis

(74) *Attorney, Agent, or Firm* — Fitch, Even, Tabin & Flannery, LLP

(57) **CLAIM**

The ornamental design for a temperature sensor, as shown and described.

FIG. 1 is an enlarged perspective view of a front, top and right side view of a temperature sensor showing our new design;  
FIG. 2 is a front elevational view thereof;  
FIG. 3 is a rear elevational view thereof;  
FIG. 4 is a left side elevational view thereof;  
FIG. 5 is a right side elevational view thereof;  
FIG. 6 is a top plan view thereof;  
FIG. 7 is a bottom plan view thereof.  
FIG. 8 is an enlarged portion left side elevational view thereof;  
FIG. 9 is an enlarged portion right side elevational view thereof;  
FIG. 10 is an enlarged portion view taken along line 10-10 in FIG. 2 thereof;  
FIG. 11 is an enlarged portion view taken along line 11-11 in FIG. 2 thereof;  
FIG. 12 is an enlarged portion view taken along line 12-12 in FIG. 2 thereof;  
FIG. 13 is an enlarged portion view taken along line 13-13 in FIG. 2 thereof;  
FIG. 14 is an enlarged portion view taken along line 14-14 in FIG. 6 thereof;  
FIG. 15 is an enlarged portion view taken along line 15-15 in FIG. 6 thereof;  
FIG. 16 is an enlarged portion view taken along line 16-16 in FIG. 6 thereof;  
FIG. 17 is an enlarged portion view taken along line 17-17 in FIG. 6 thereof;  
FIG. 18 is an enlarged cross sectional taken along line 18-18 in FIG. 11 thereof;  
FIG. 19 is an enlarged cross sectional taken along line 19-19 in FIG. 11 thereof;  
FIG. 20 is an enlarged perspective view taken along line 20-20 in FIG. 11 thereof;  
FIG. 21 is an enlarged cross sectional taken along line 21-21 in FIG. 11 thereof;  
FIG. 22 is an enlarged cross sectional taken along line 22-22 in FIG. 11 thereof;  
FIG. 23 is an enlarged perspective view taken along line 23-23 in FIG. 11 thereof;

(Continued)

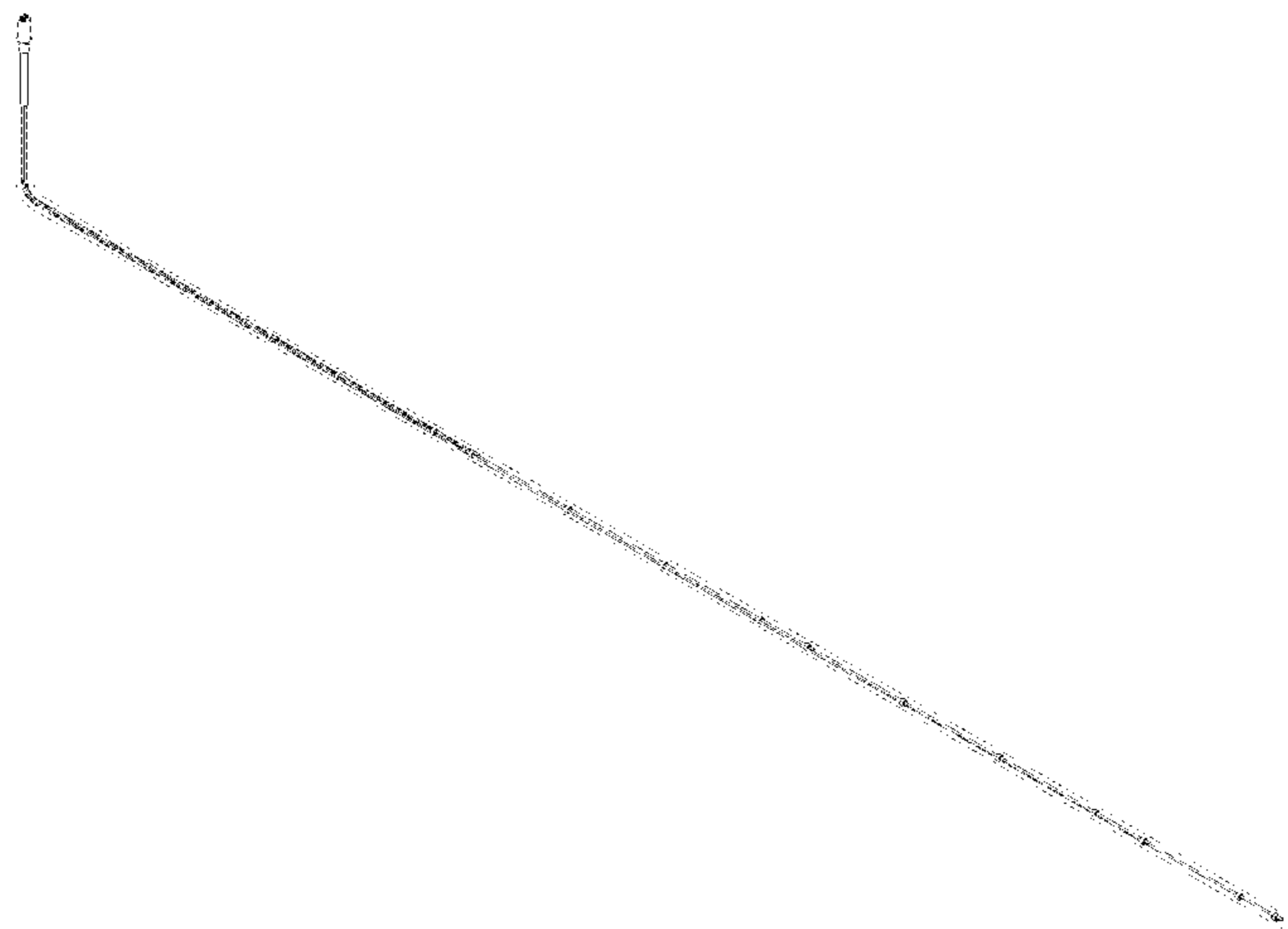

FIG. 24 is an enlarged cross sectional taken along line 24-24 in FIG. 11 thereof;  
FIG. 25 is an enlarged cross sectional taken along line 25-25 in FIG. 11 thereof;  
FIG. 26 is an enlarged perspective view taken along line 26-26 in FIG. 11 thereof;  
FIG. 27 is an enlarged cross sectional taken along line 27-27 in FIG. 12 thereof;  
FIG. 28 is an enlarged cross sectional taken along line 28-28 in FIG. 12 thereof;  
FIG. 29 is an enlarged perspective view taken along line 29-29 in FIG. 12 thereof;  
FIG. 30 is an enlarged cross sectional taken along line 30-30 in FIG. 13 thereof;  
FIG. 31 is an enlarged cross sectional taken along line 31-31 in FIG. 13 thereof;  
FIG. 32 is an enlarged perspective view taken along line 32-32 in FIG. 13 thereof;  
FIG. 33 is an enlarged cross sectional taken along line 33-33 in FIG. 13 thereof;  
FIG. 34 is an enlarged cross sectional taken along line 34-34 in FIG. 13 thereof; and,  
FIG. 35 is an enlarged perspective view taken along line 35-35 in FIG. 13.

The broken lines shown in the drawings represent portions of the temperature sensor that form no part of the claimed design.

**1 Claim, 18 Drawing Sheets**

(58) **Field of Classification Search**

CPC ..... G01K 7/02; G01K 7/023; G01K 7/026;  
G01K 7/028; G01K 7/04; G01K 7/06;  
G01K 7/08; G01K 7/10; G01K 7/12;  
G01K 7/13; G01K 7/14; G01K 1/12;  
G01K 1/08; G01K 1/125; G01K 1/10;  
G01K 1/105; C23C 16/52; H01L 21/22;  
H01L 21/31

See application file for complete search history.

(56) **References Cited**

U.S. PATENT DOCUMENTS

9,791,328 B2 \* 10/2017 Chu ..... G01K 1/024  
D803,075 S \* 11/2017 Akao ..... D10/60  
9,816,879 B2 \* 11/2017 Sannier ..... G01K 13/02  
D818,850 S \* 5/2018 Akao ..... D10/52  
D819,463 S \* 6/2018 Akao ..... D10/60

\* cited by examiner

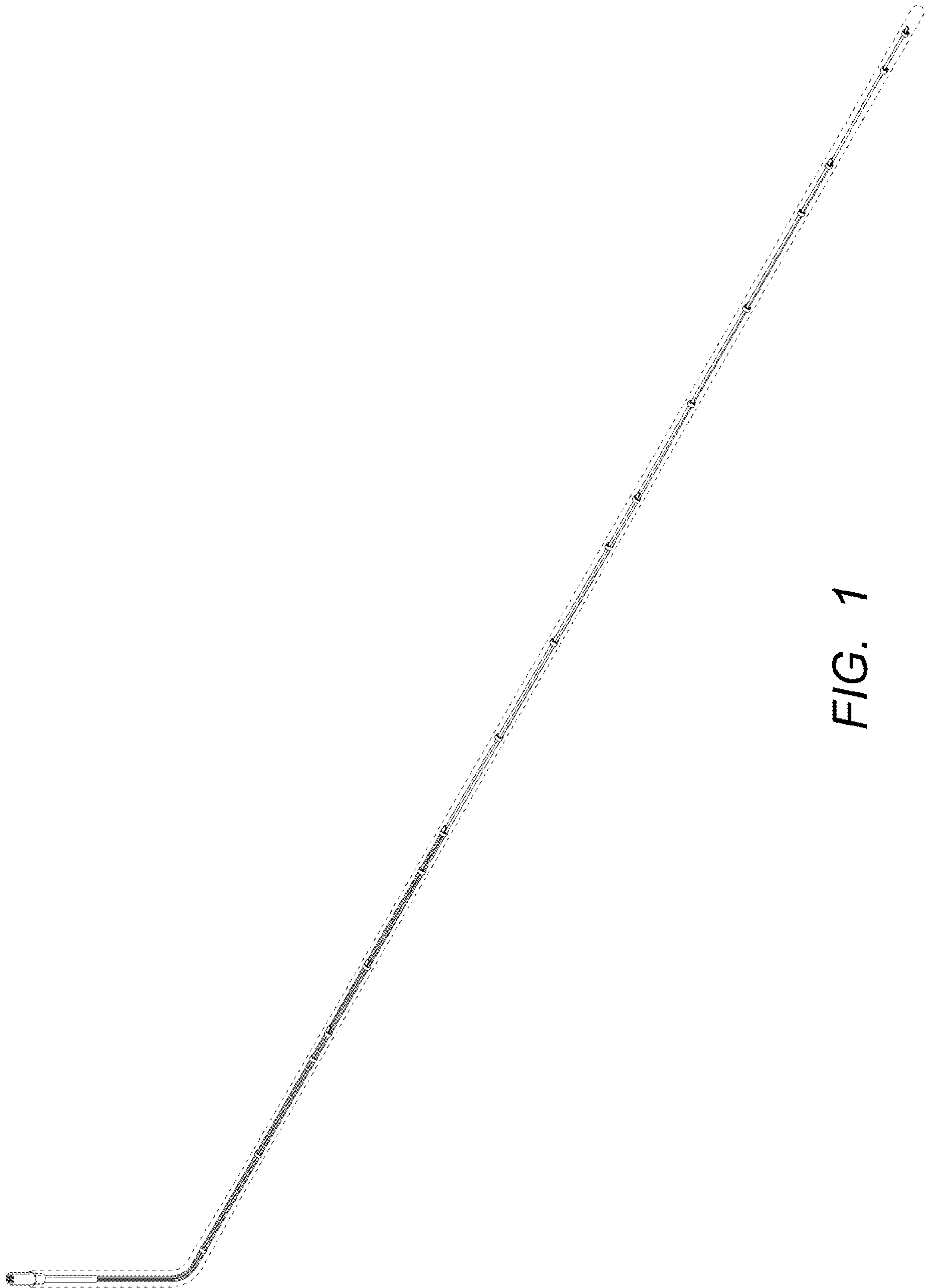

FIG. 1

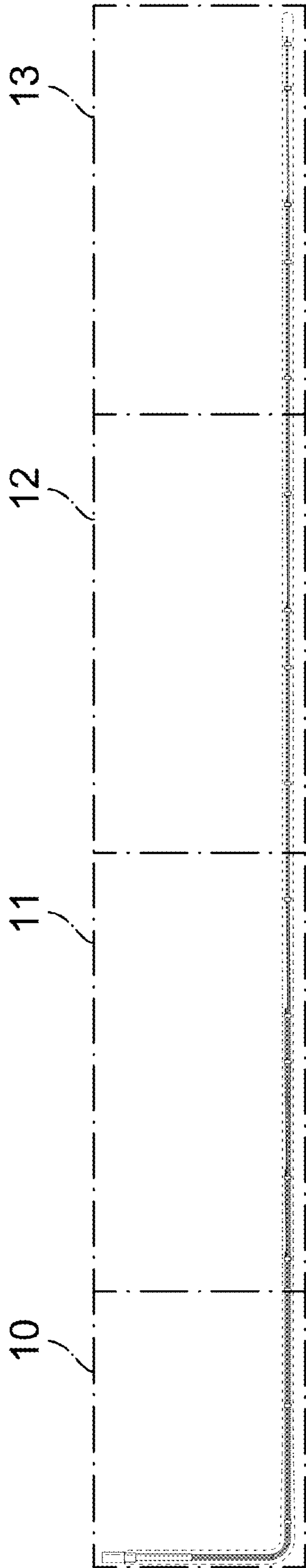

FIG. 2

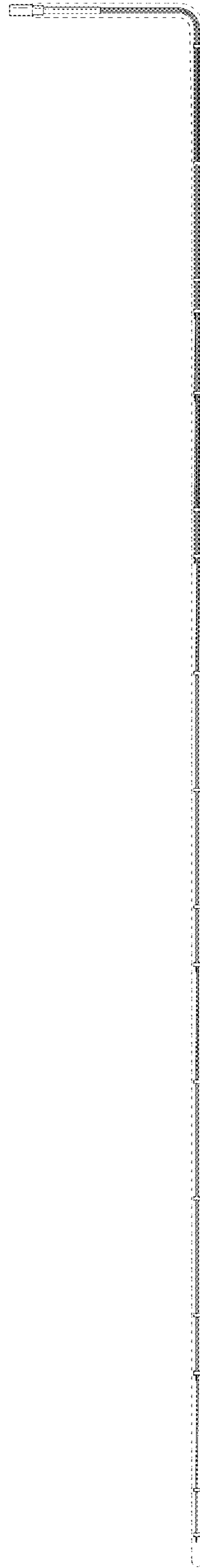

FIG. 3



FIG. 4      FIG. 5



FIG. 6



FIG. 7

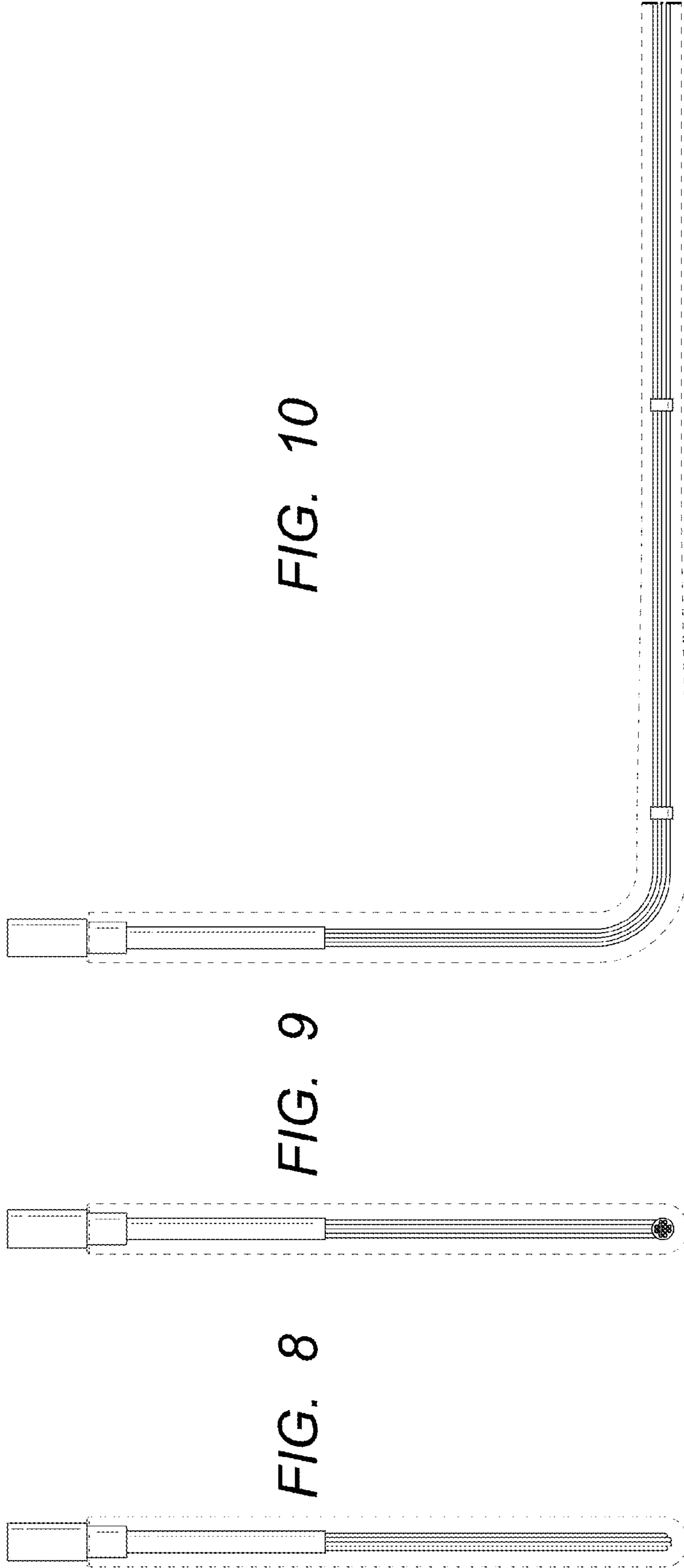

FIG. 10

FIG. 9

FIG. 8

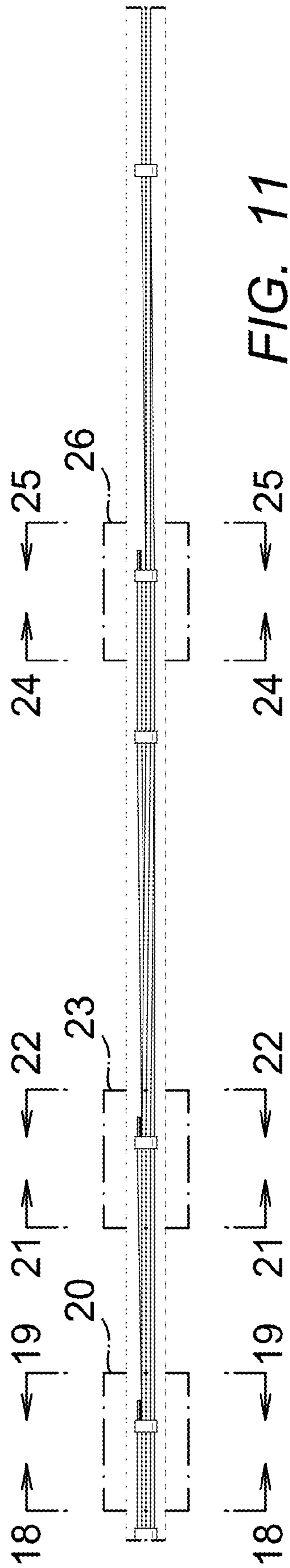

FIG. 11

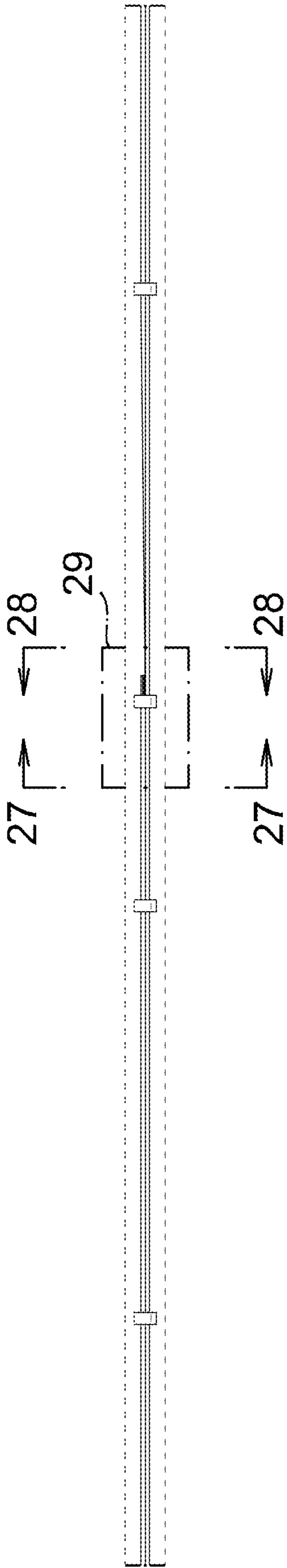

FIG. 12

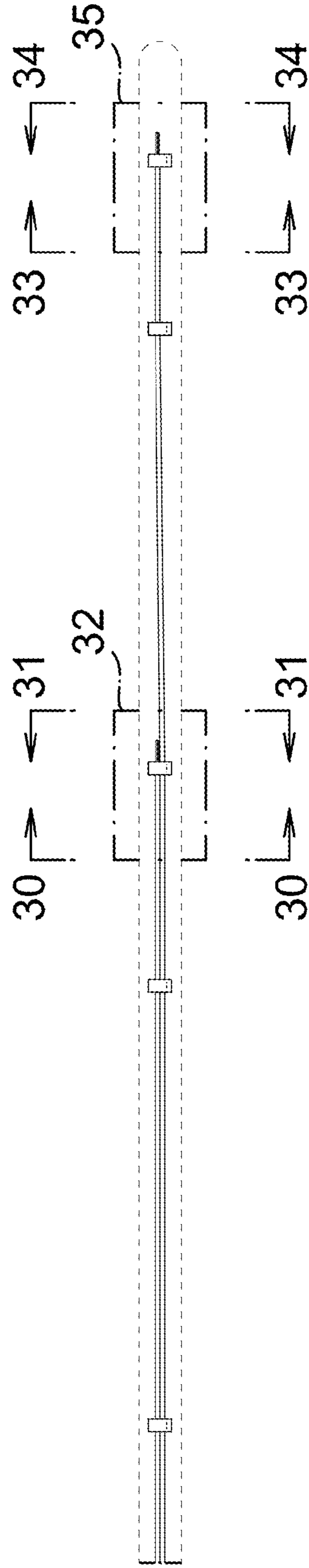

FIG. 13

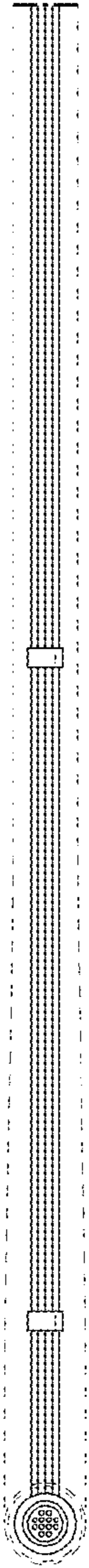

FIG. 14

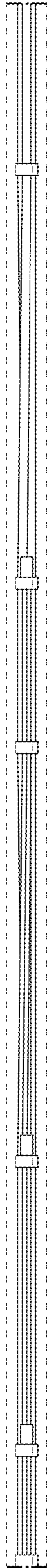

FIG. 15

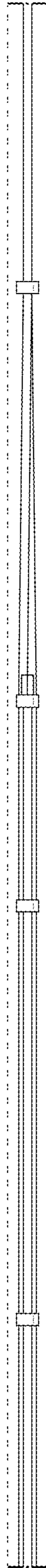

FIG. 16

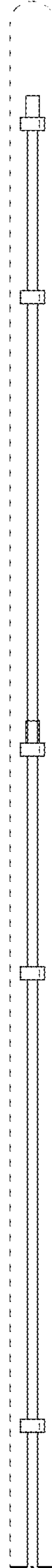

FIG. 17



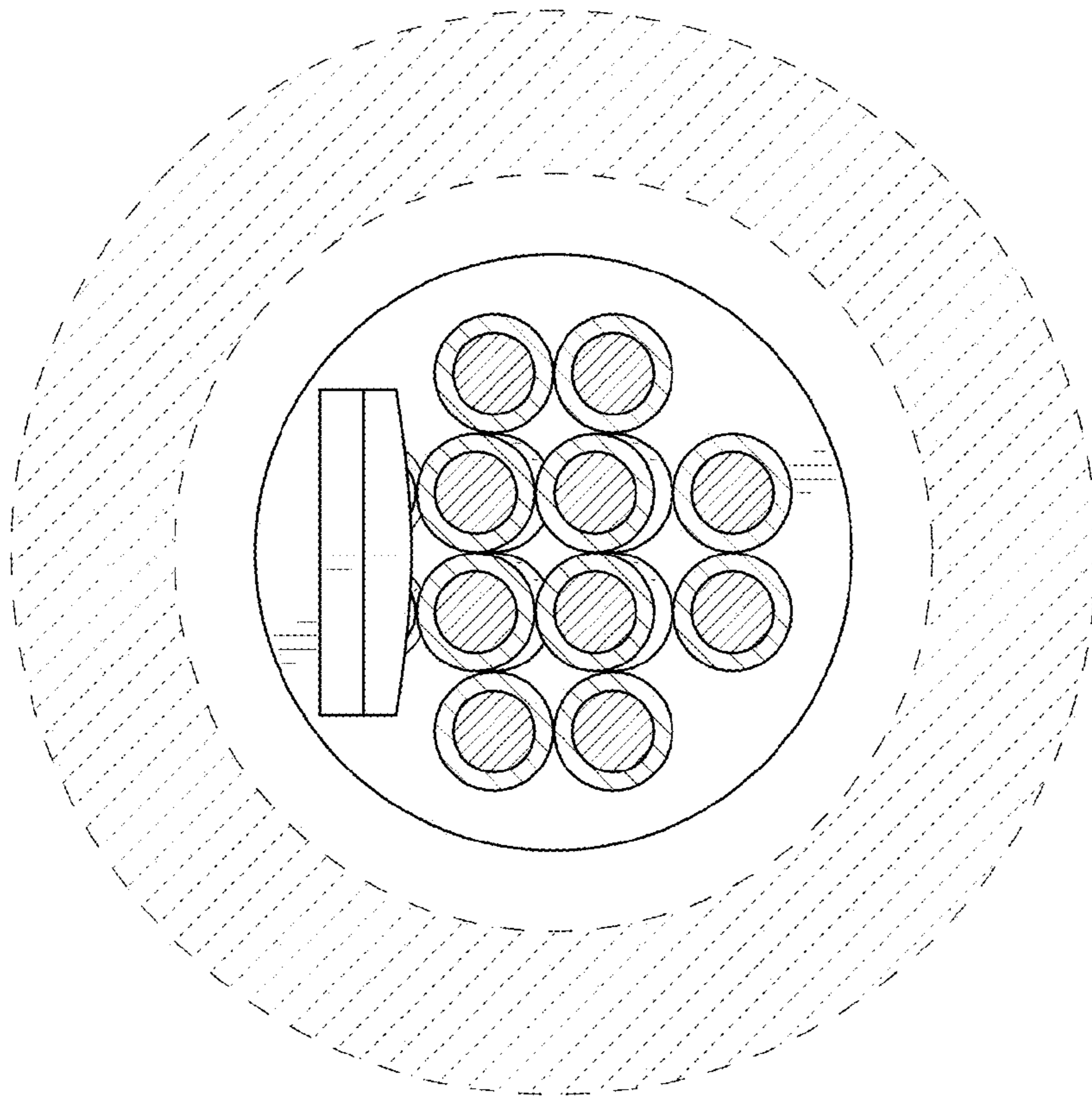

FIG. 19

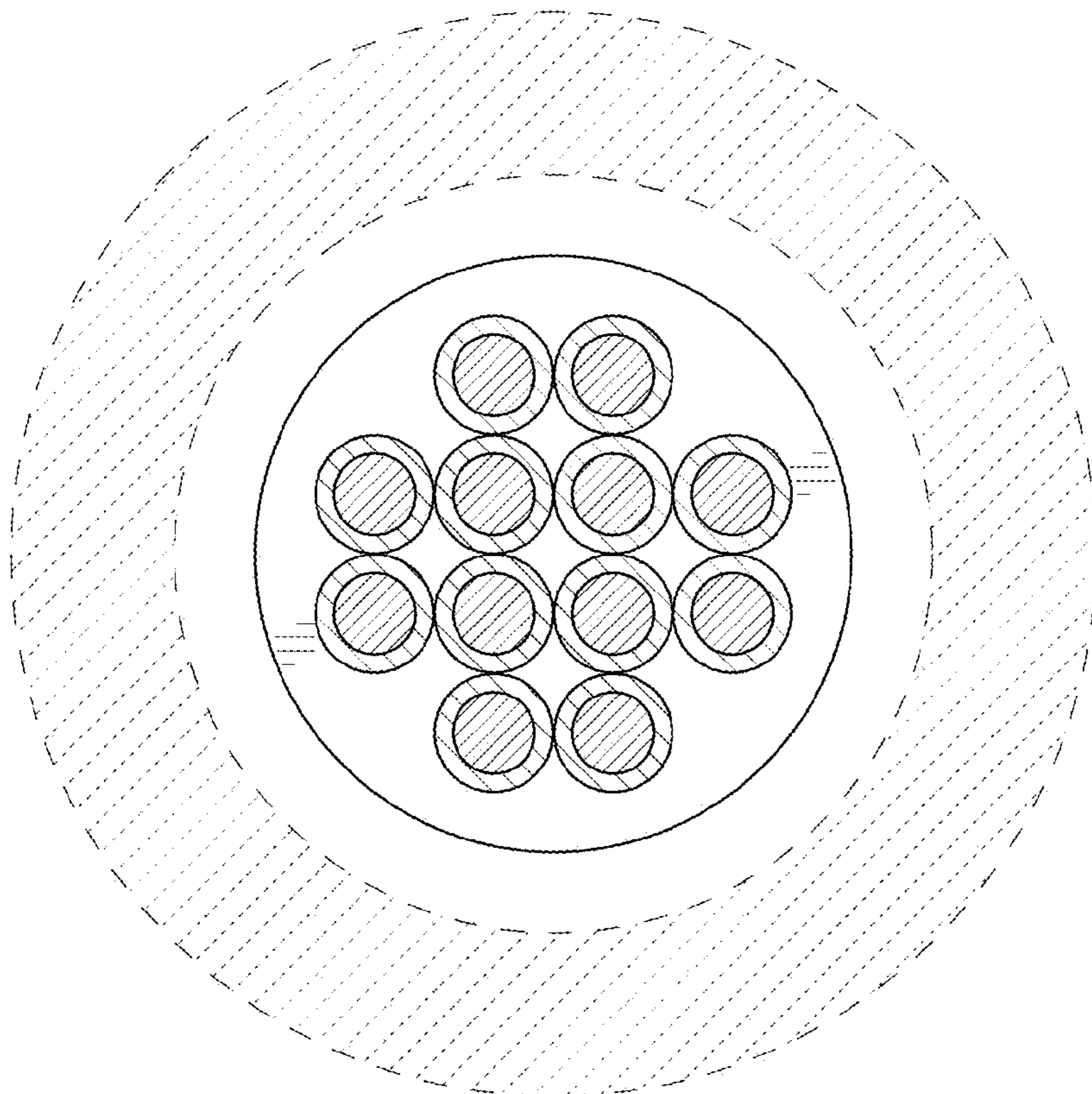

FIG. 18

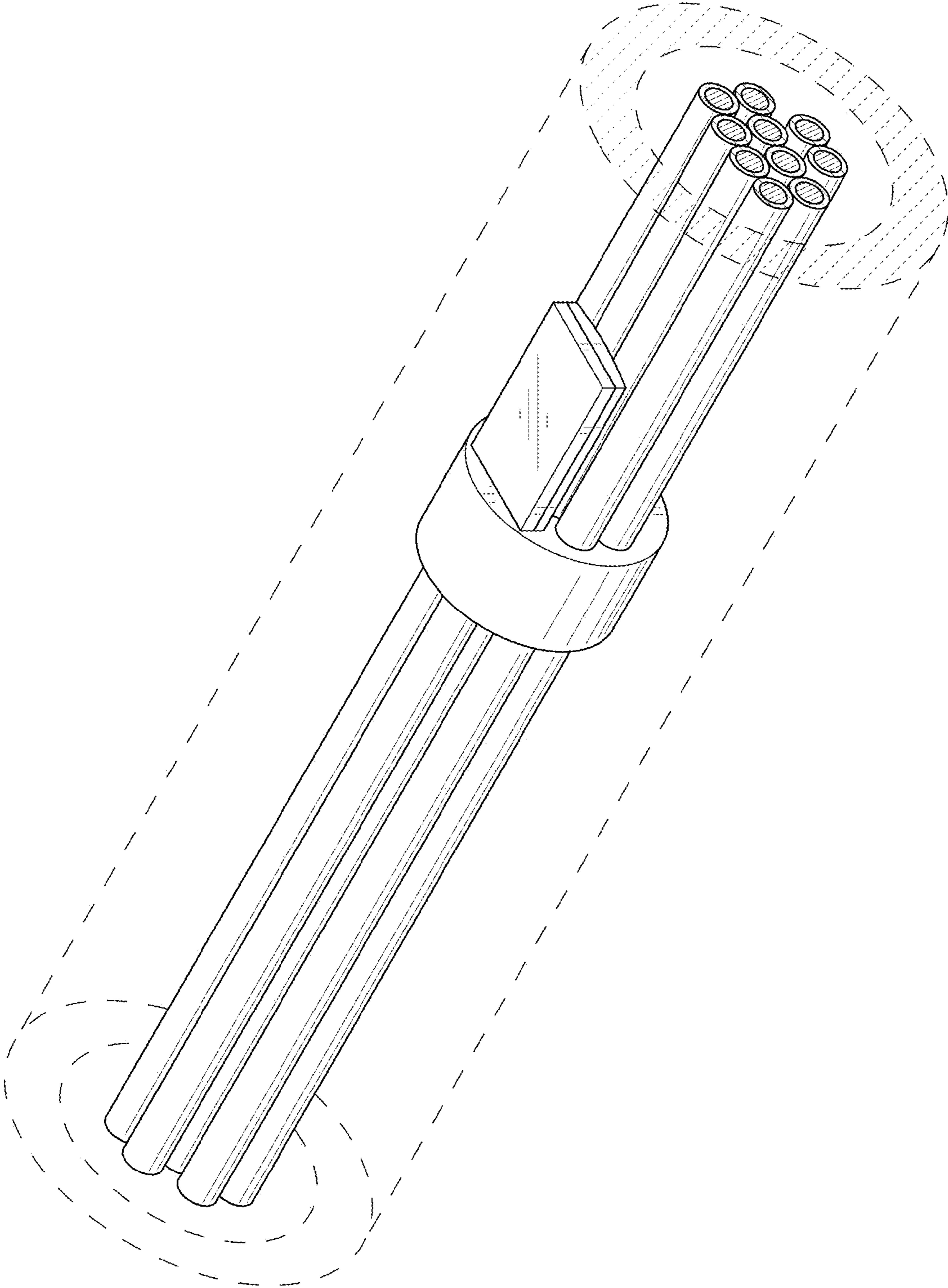

FIG. 20

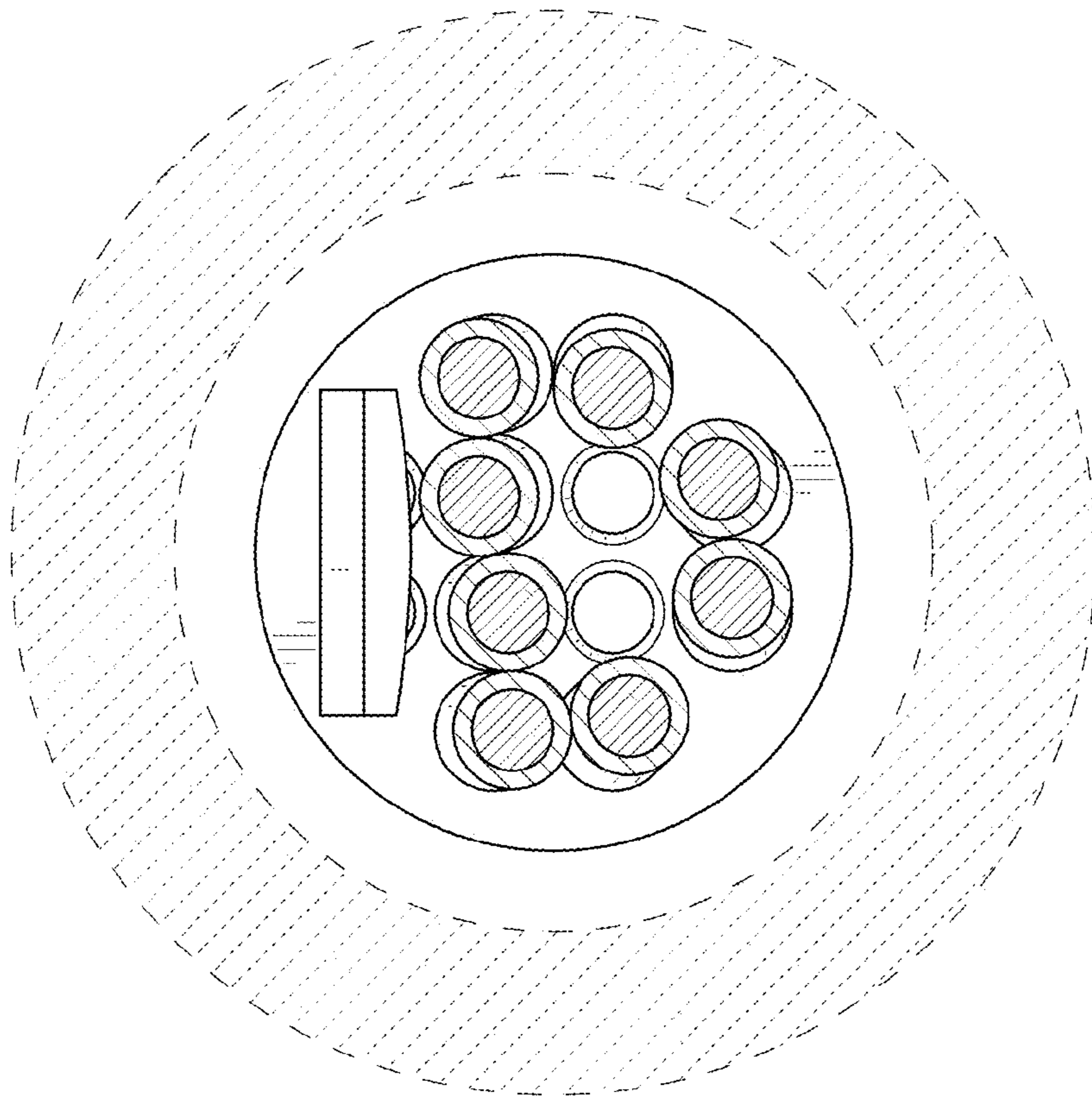

FIG. 22

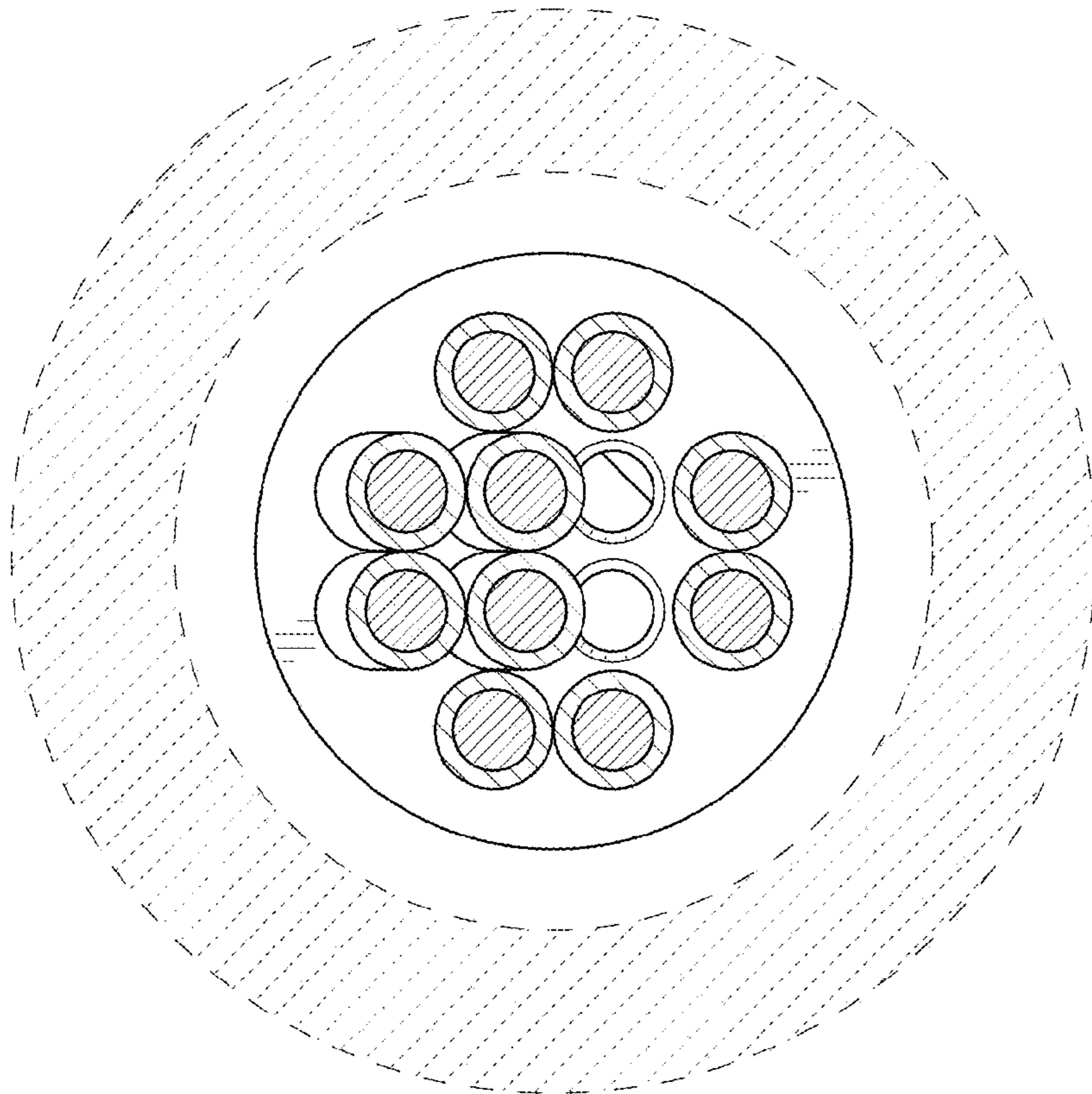

FIG. 21

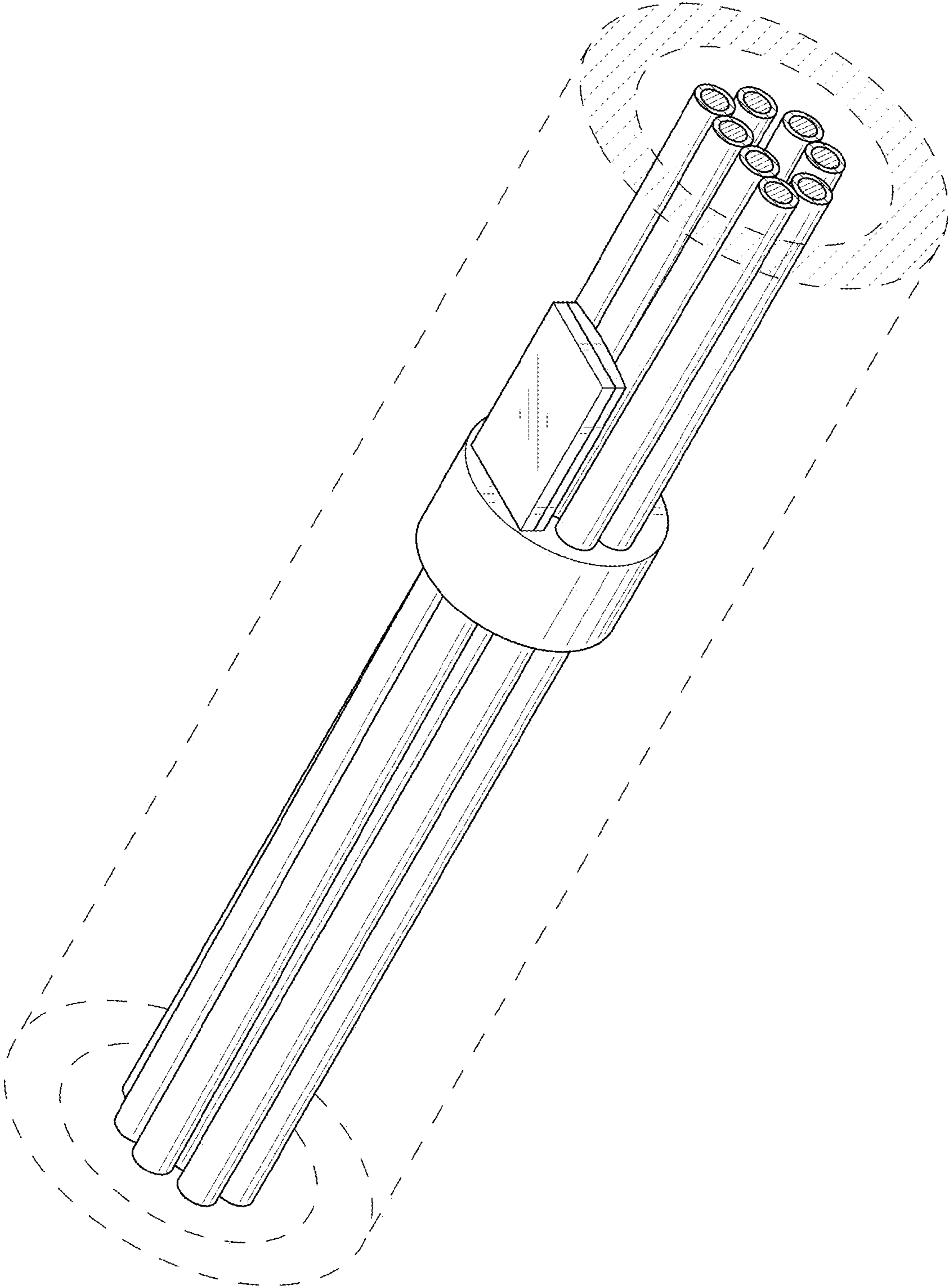

FIG. 23

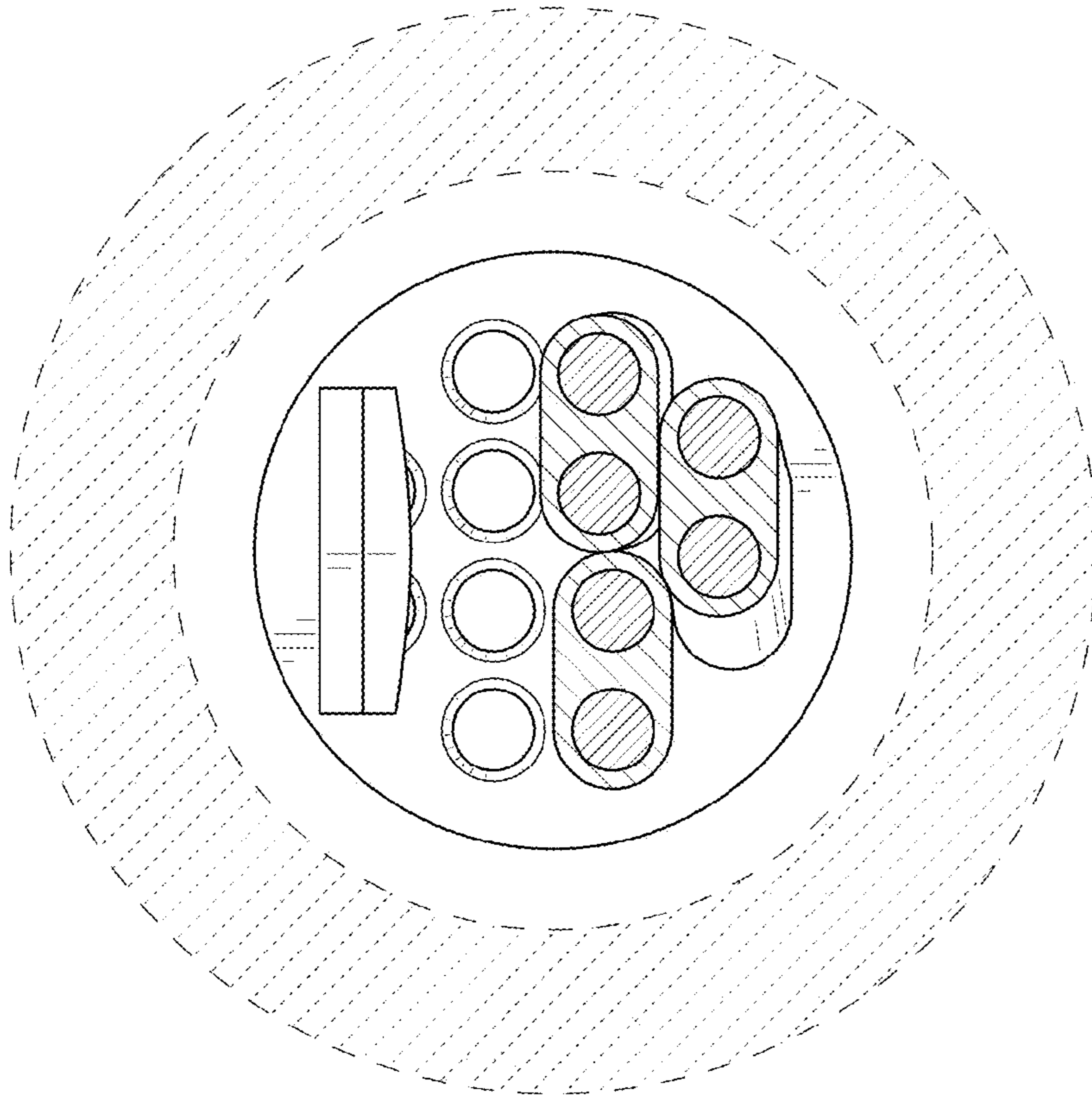

FIG. 25

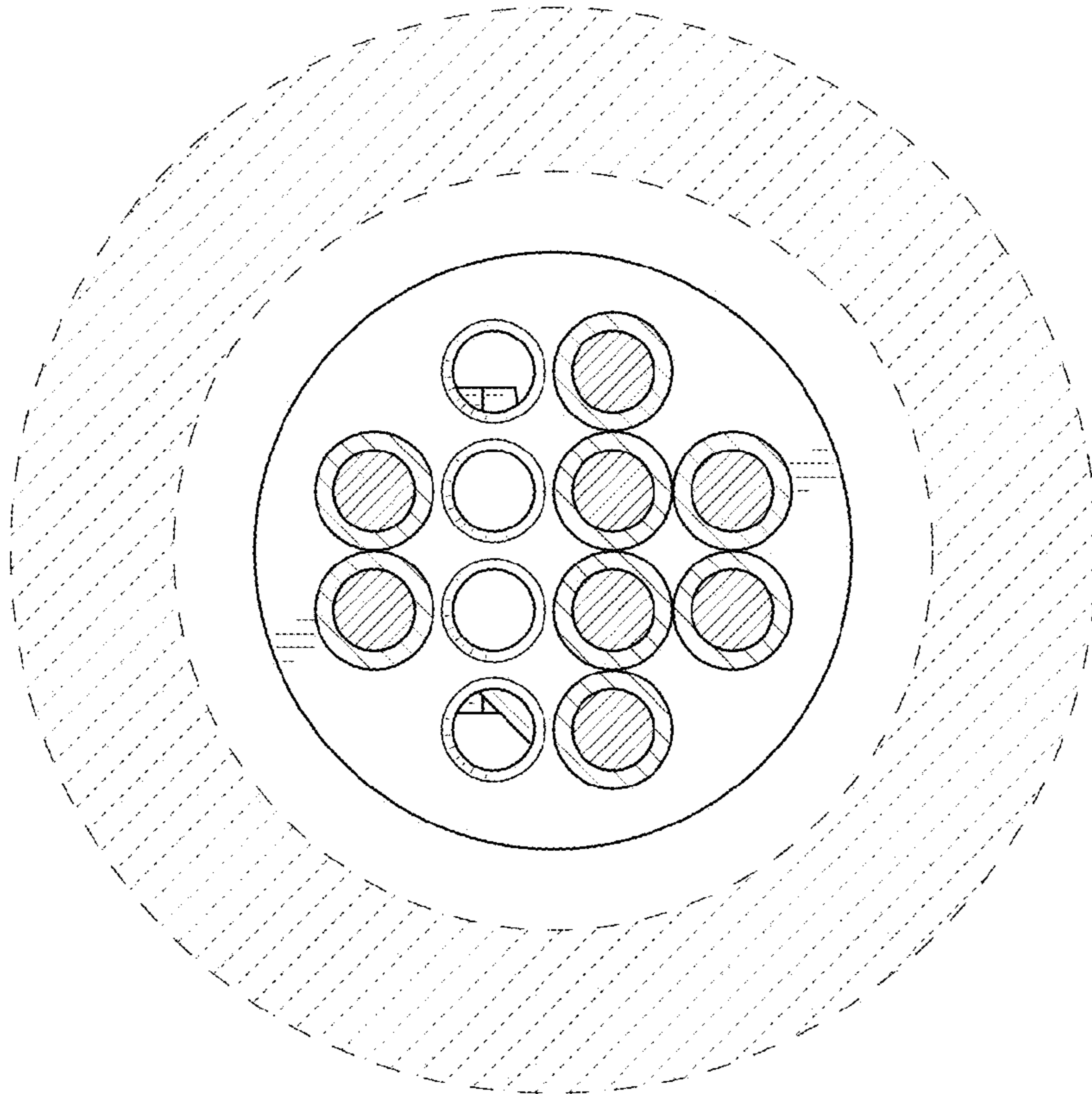

FIG. 24

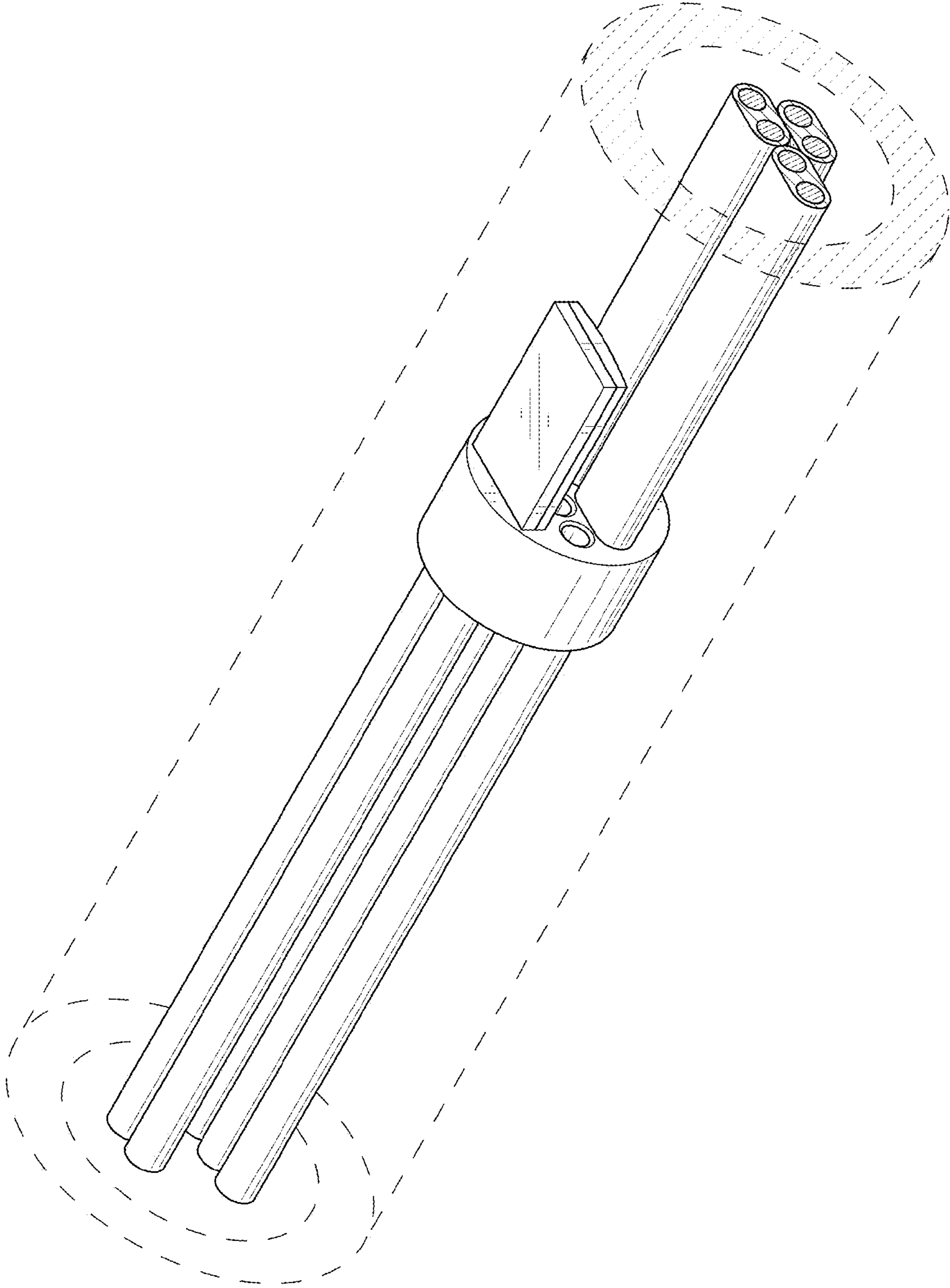

FIG. 26

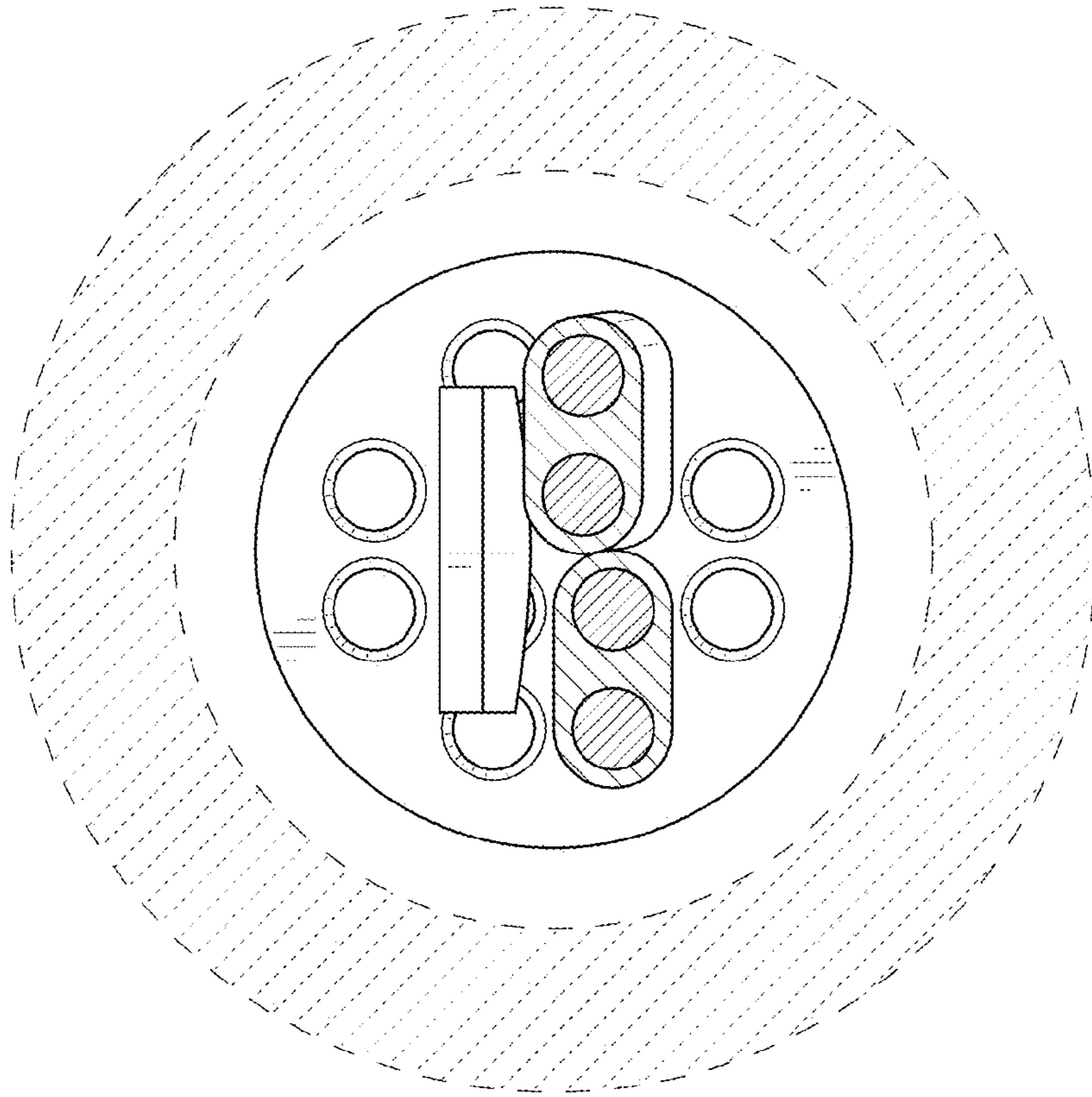

FIG. 28

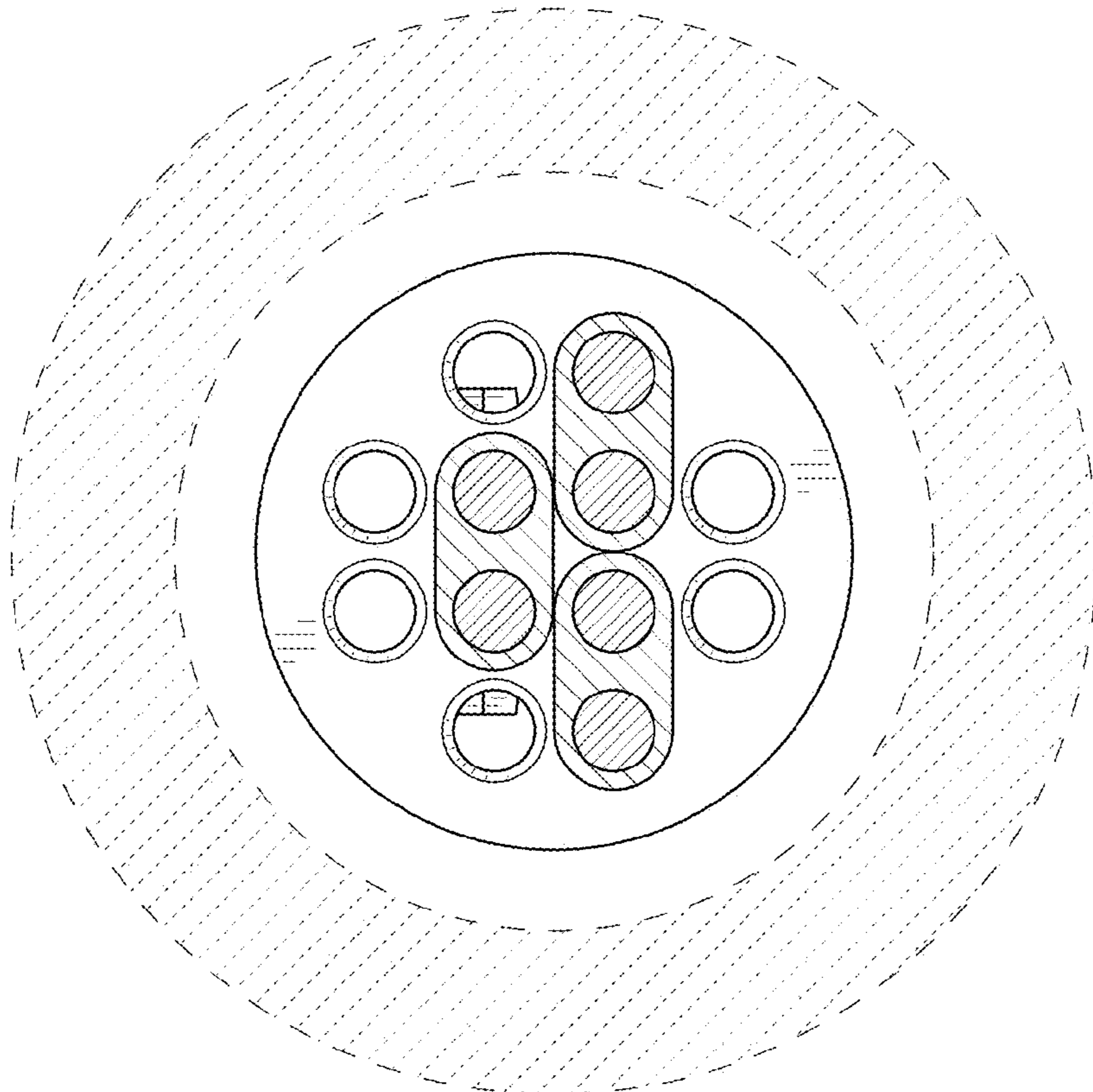

FIG. 27

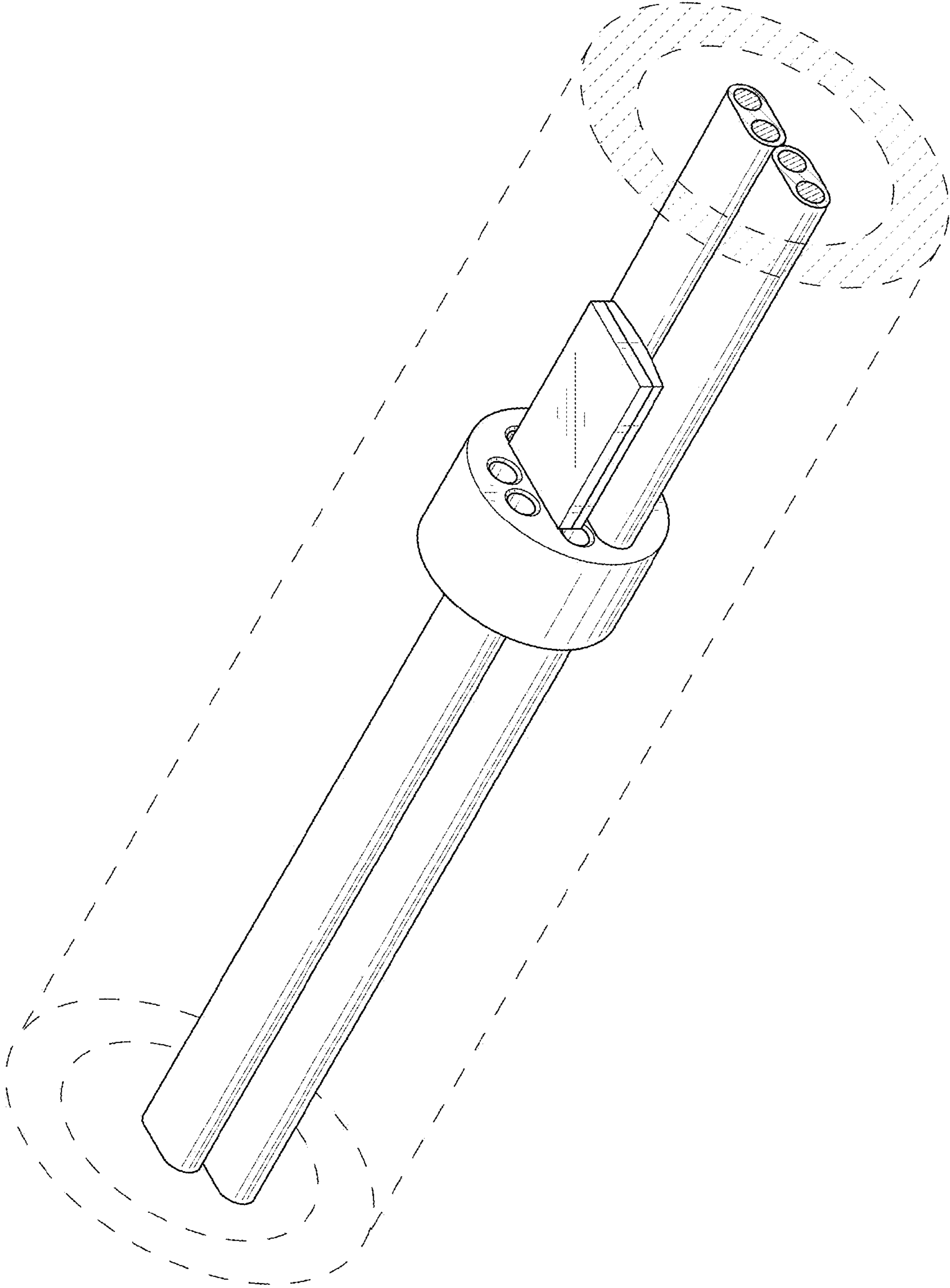

FIG. 29



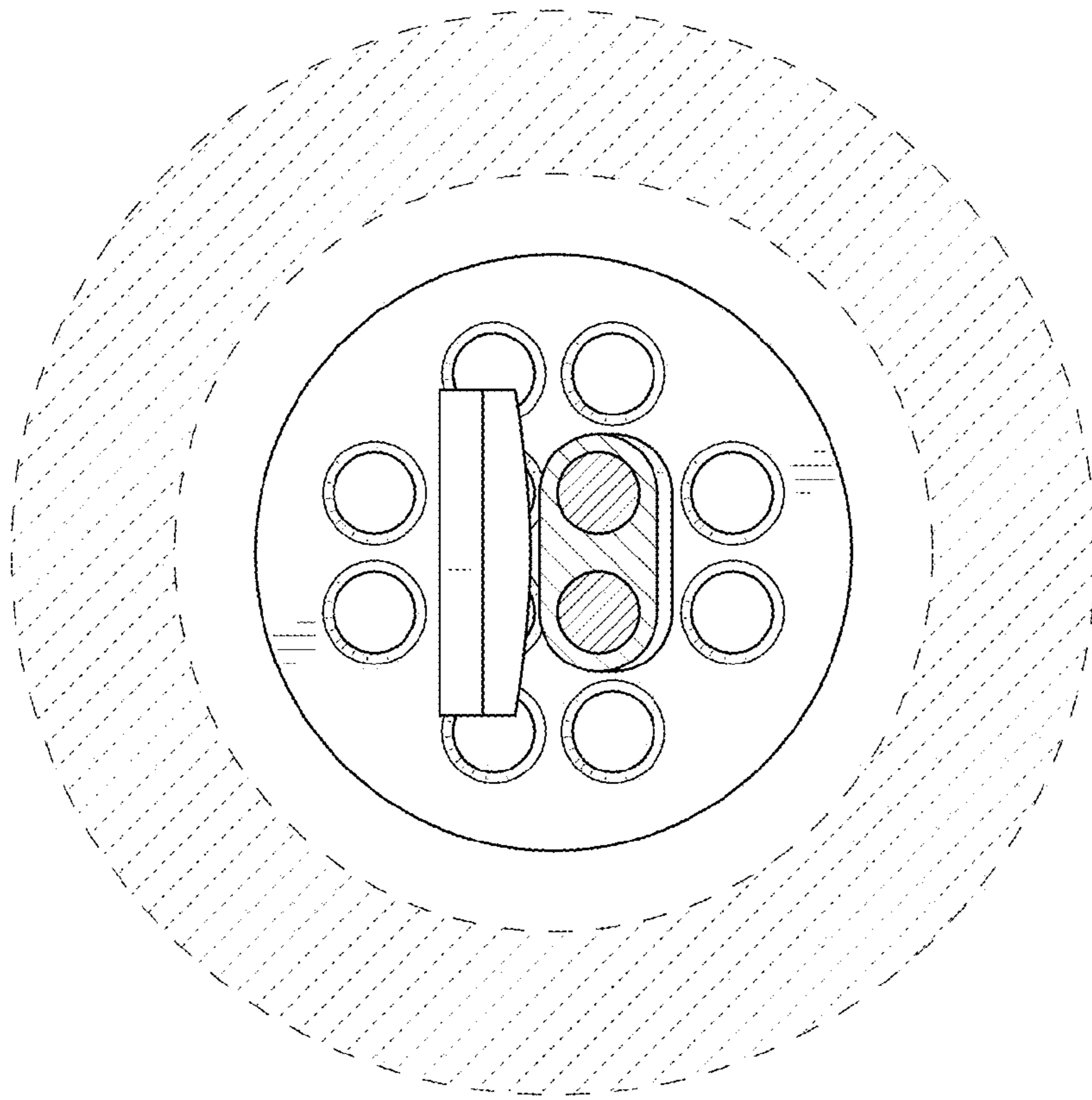

FIG. 31

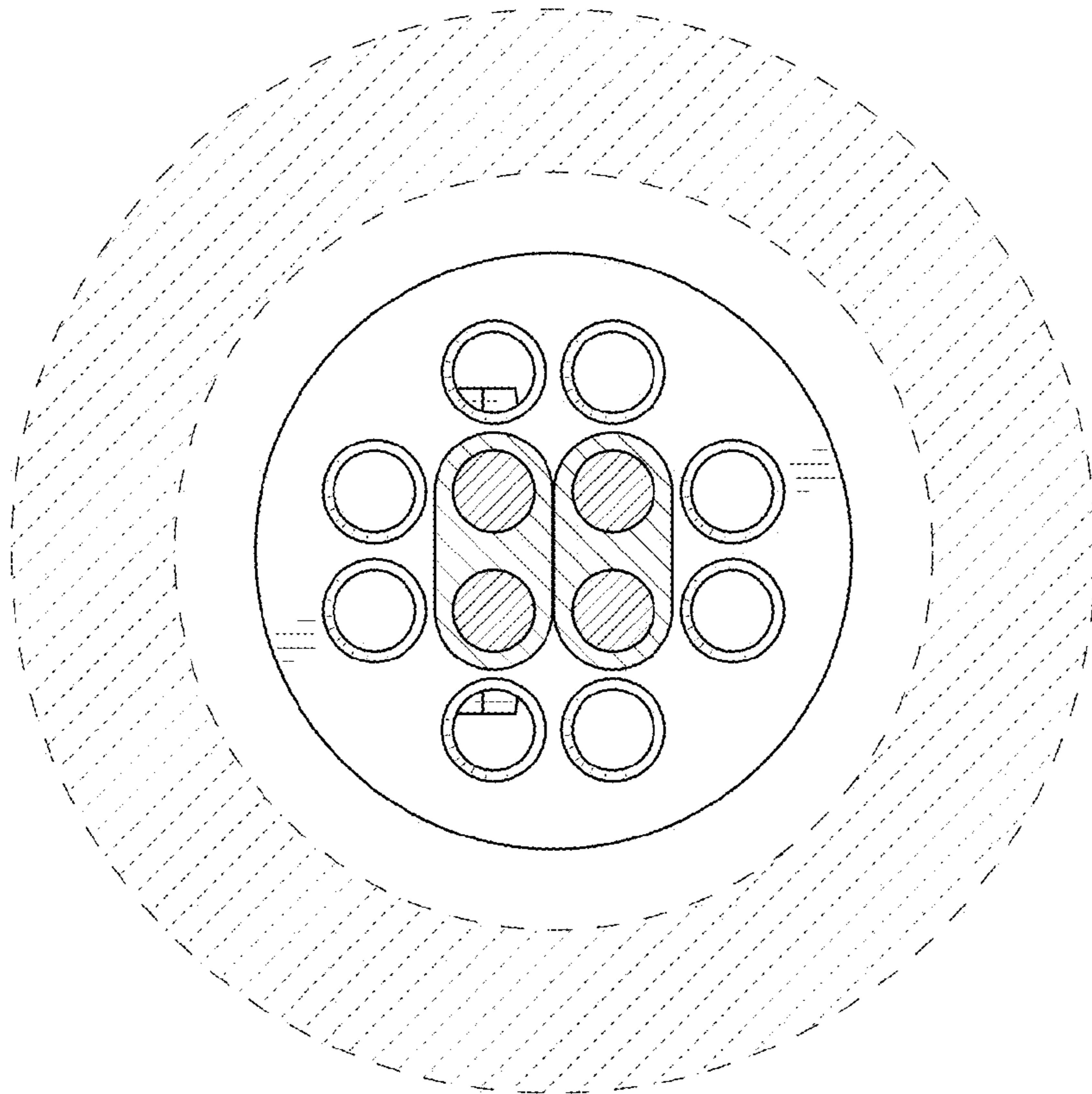

FIG. 30

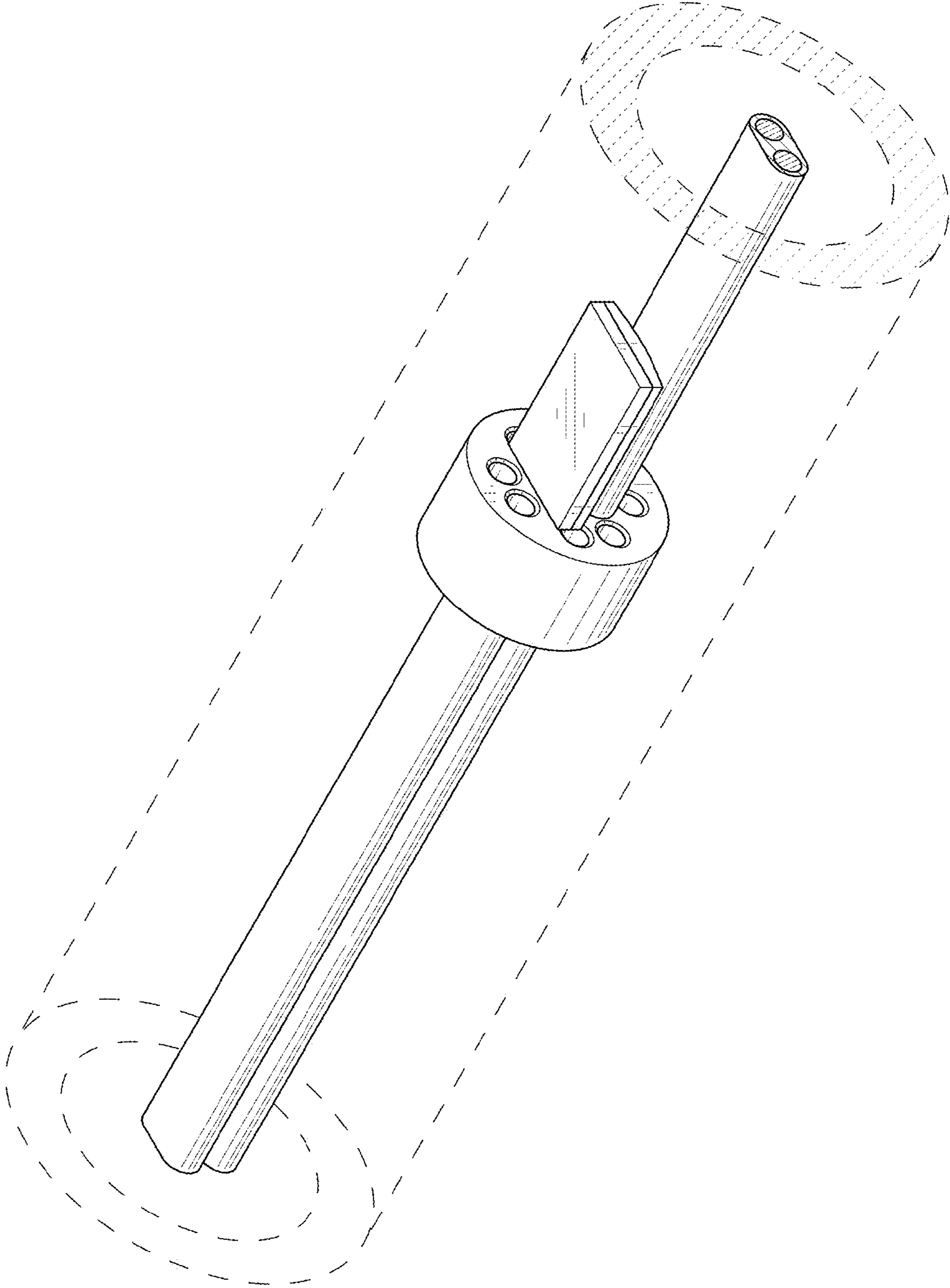

FIG. 32

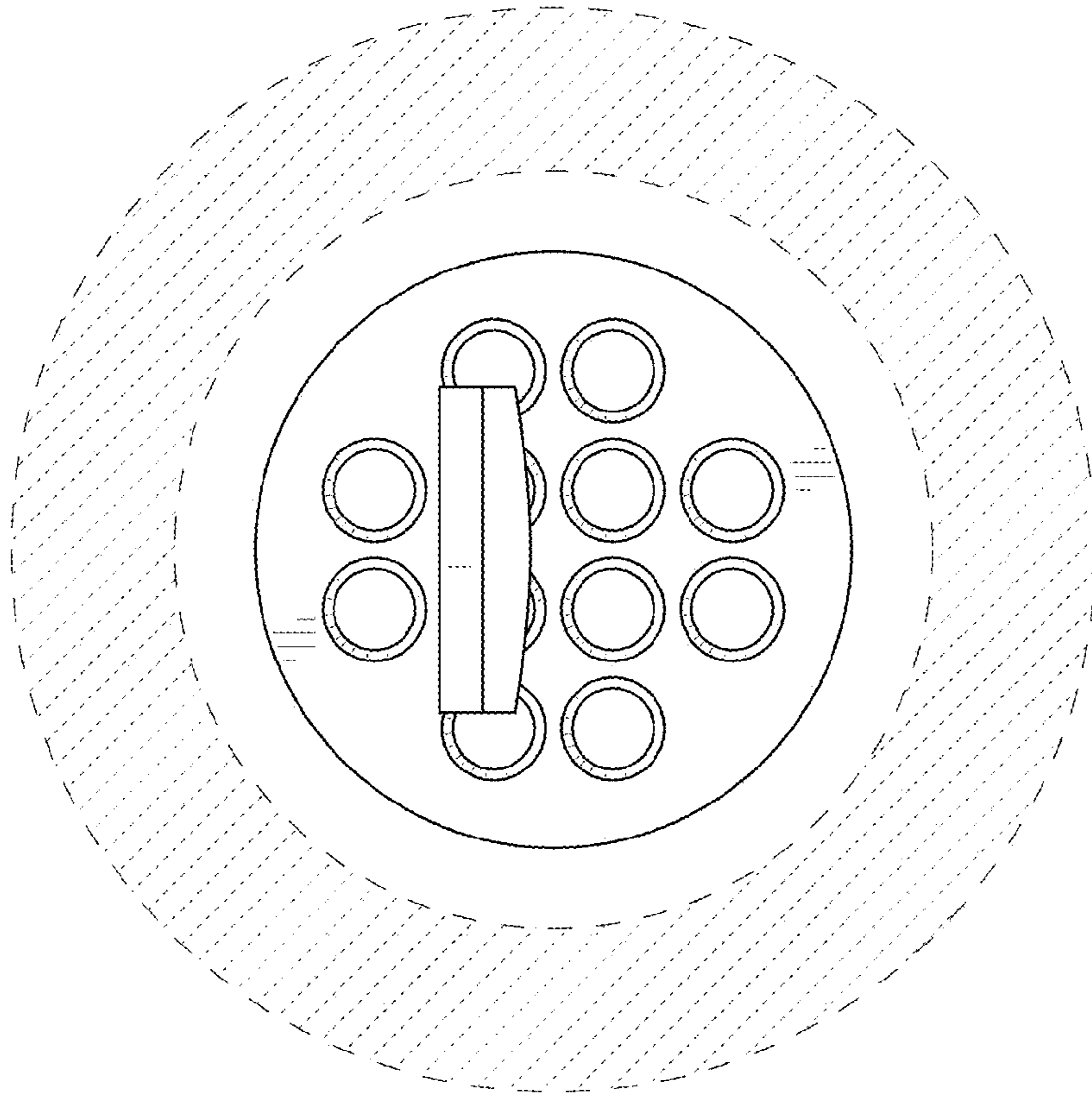

FIG. 34

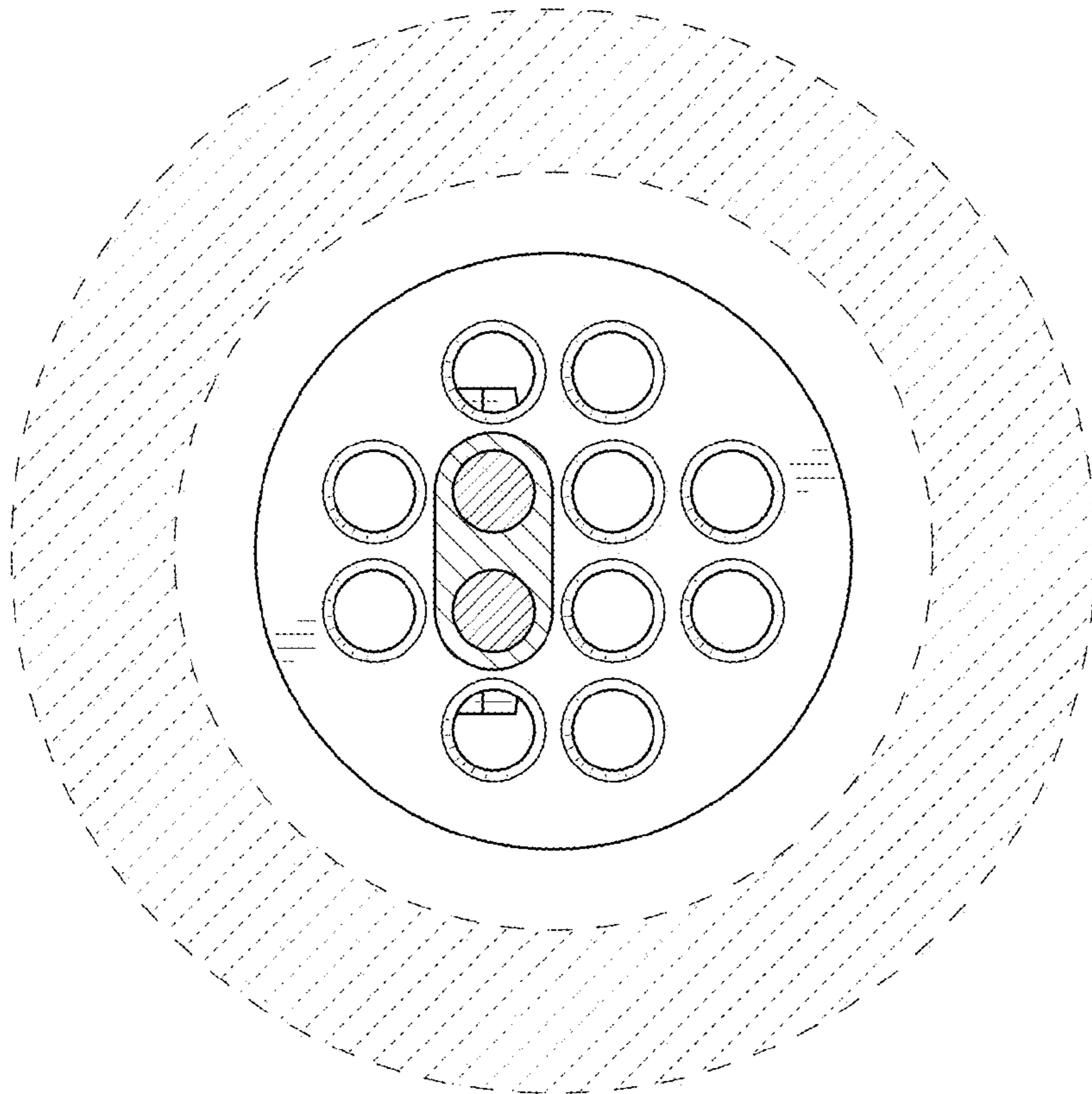

FIG. 33

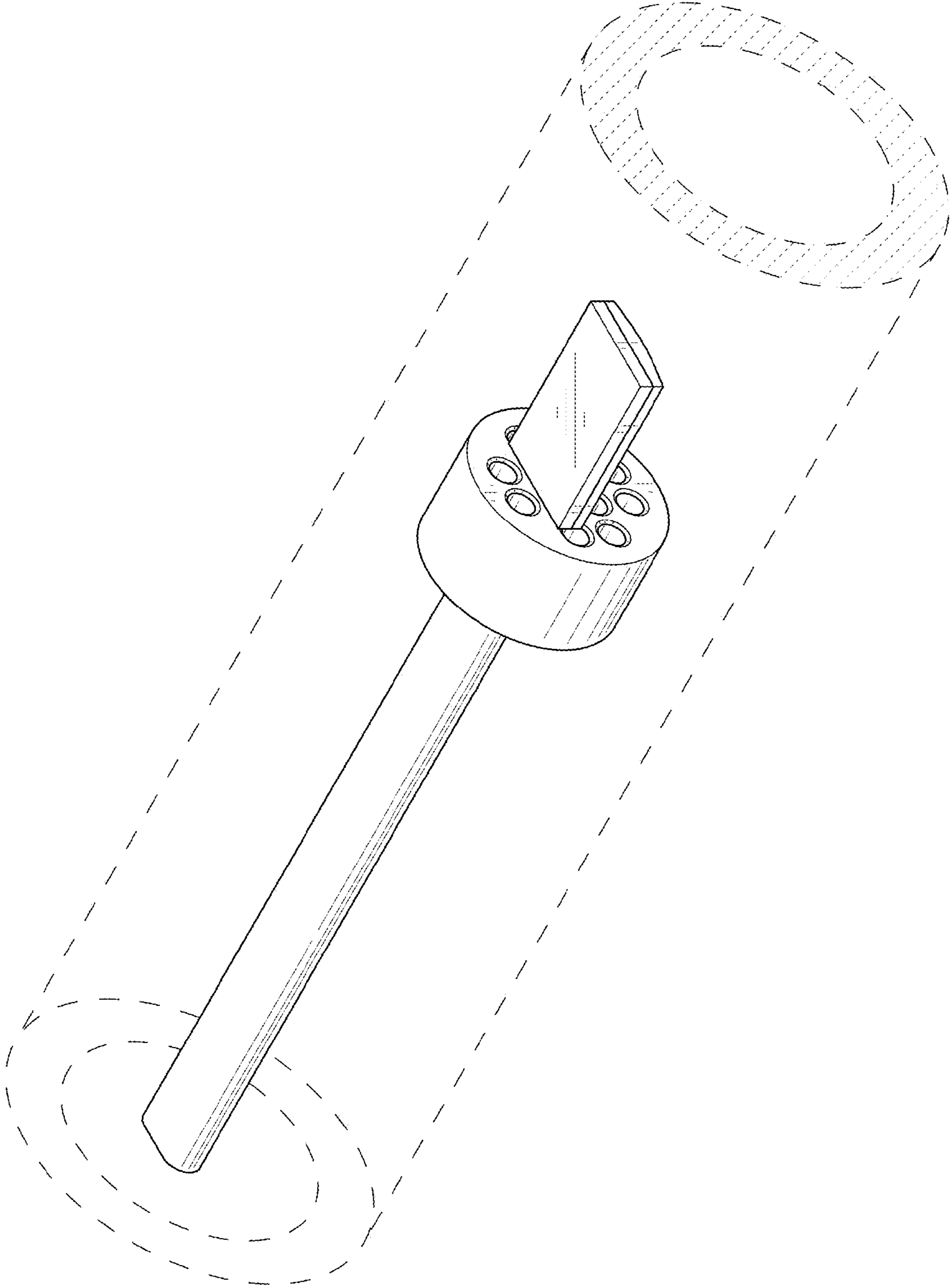

FIG. 35