



US00D975744S

(12) **United States Design Patent**
Goos et al.

(10) **Patent No.:** **US D975,744 S**
(45) **Date of Patent:** **** Jan. 17, 2023**

- (54) **ELECTRIC MOTOR ADAPTER**
- (71) Applicant: **SEW-EURODRIVE GmbH & Co KG**, Bruchsal (DE)
- (72) Inventors: **Jürgen Goos**, Speyer (DE); **Julian Kratz**, Kraichtal (DE); **Philipp Merkel**, Karlsbad (DE); **Bettina Baacke**, Karlsruhe (DE)
- (73) Assignee: **SEW-EURODRIVE GmbH & Co KG**, Bruchsal (DE)
- (**) Term: **15 Years**
- (21) Appl. No.: **29/761,471**
- (22) Filed: **Dec. 9, 2020**
- (30) **Foreign Application Priority Data**

- Jun. 10, 2020 (EP) 007993738
- (51) **LOC (14) Cl.** **15-01**
- (52) **U.S. Cl.**
USPC **D15/5**
- (58) **Field of Classification Search**
USPC D15/1, 2, 3, 4, 5, 6, 148, 149; D13/112, D13/113, 114, 118
See application file for complete search history.

- (56) **References Cited**
U.S. PATENT DOCUMENTS
- D220,881 S * 6/1971 Dochterman D13/114
- 4,431,073 A * 2/1984 Nagao F16H 63/3023
475/83
- D479,543 S * 9/2003 Lannoch D15/148
- D703,253 S * 4/2014 Lannoch D15/148
- D704,756 S * 5/2014 Voelker D15/148
- 8,733,196 B2 * 5/2014 Goppelsroder F16H 57/021
74/606 R

D797,173 S *	9/2017	Ebner	D15/148
D800,198 S *	10/2017	Branning	D15/149
D802,640 S *	11/2017	Hannet	D15/149
D809,039 S *	1/2018	Ebner	D15/148
D833,495 S *	11/2018	Nakamura	D15/149
D869,531 S *	12/2019	Ascher	D15/150
D909,301 S *	2/2021	Povolo	D13/112
D915,279 S *	4/2021	Nanbu	D13/112
10,992,381 B2 *	4/2021	Hua	H04B 10/1141
D937,332 S *	11/2021	Kimura	D15/149
2007/0193408 A1 *	8/2007	Martinez	A01D 34/30 74/609
2010/0326226 A1 *	12/2010	Walston	B60K 17/08 74/606 R
2021/0194316 A1 *	6/2021	Sprague	H02K 21/16
2021/0399607 A1 *	12/2021	Beall	H02K 11/33

* cited by examiner

Primary Examiner — Ania Aman
(74) *Attorney, Agent, or Firm* — Finnegan, Henderson, Farabow, Garrett & Dunner, LLP

(57) **CLAIM**

The ornamental design for an electric motor adapter, as shown and described.

DESCRIPTION

FIG. 1 is a front, top, left perspective view of an electric motor adapter, showing the new design; FIG. 2 is a front elevation view thereof; FIG. 3 is a rear elevation view thereof; FIG. 4 is a right side view thereof; FIG. 5 is a left side view thereof; FIG. 6 is a top plan view thereof; and, FIG. 7 is a bottom plan view thereof. The broken lines of even length shown in the drawings illustrate portions of the electric motor adapter that form no part of the claimed design.

1 Claim, 7 Drawing Sheets

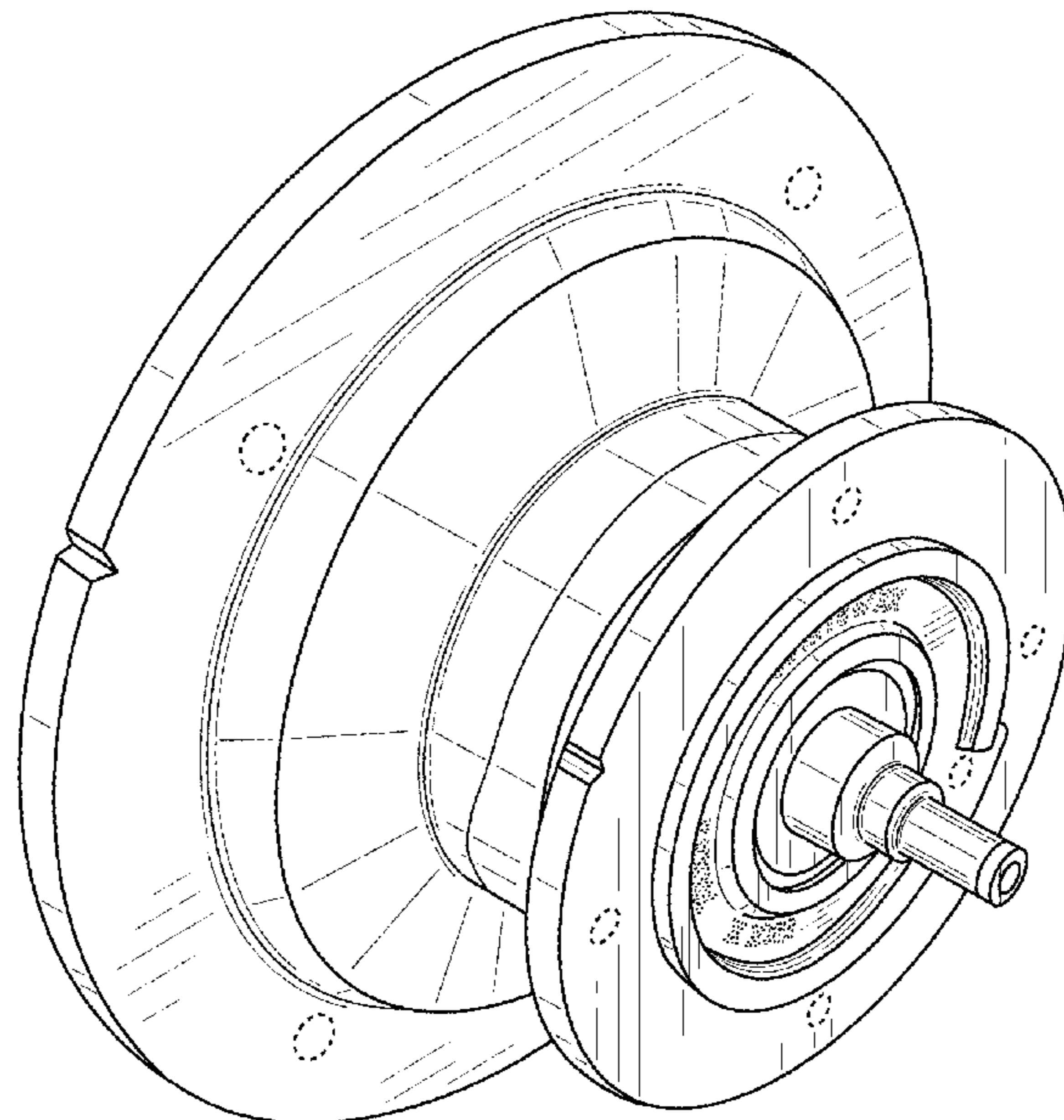

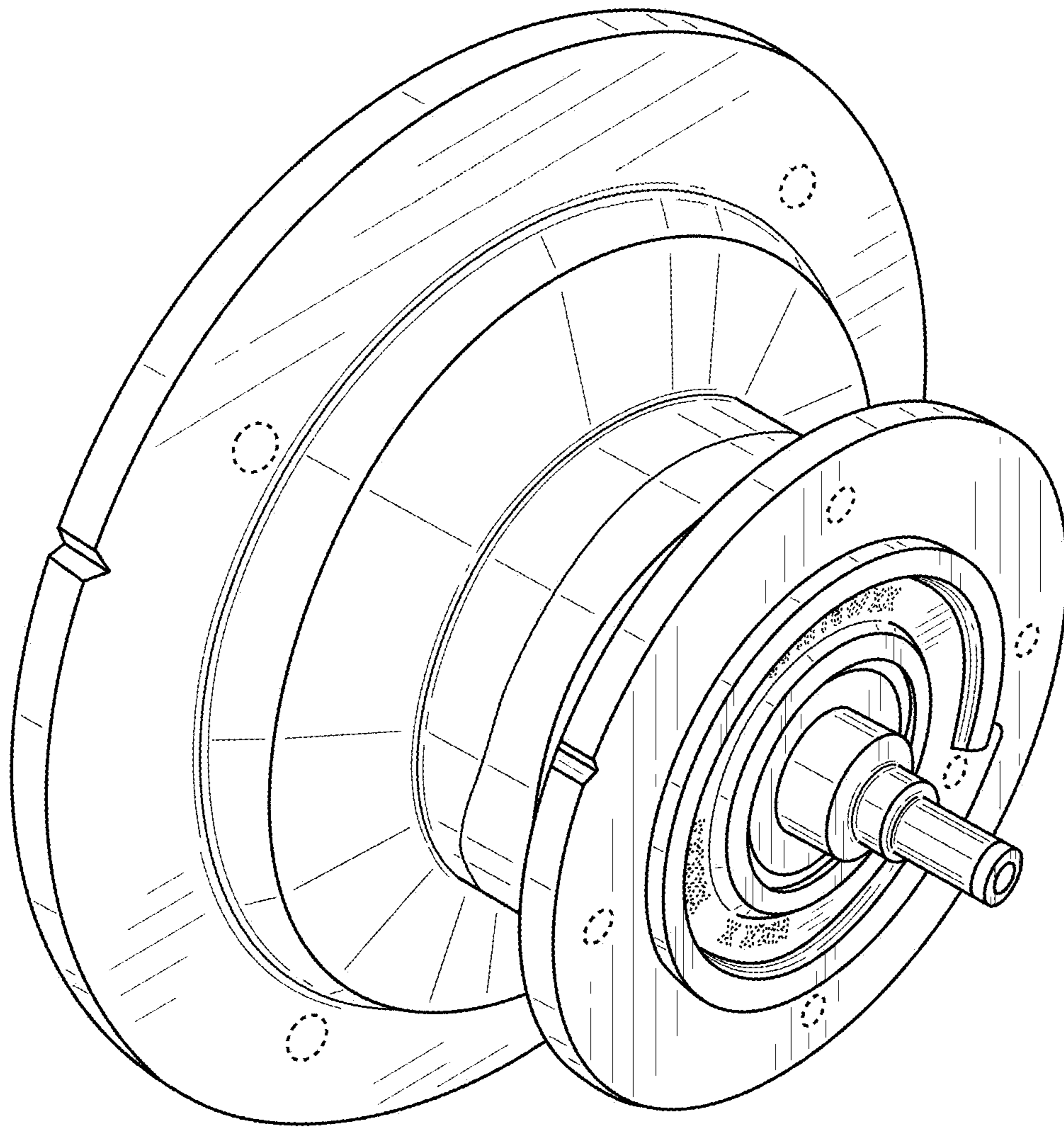

FIG. 1

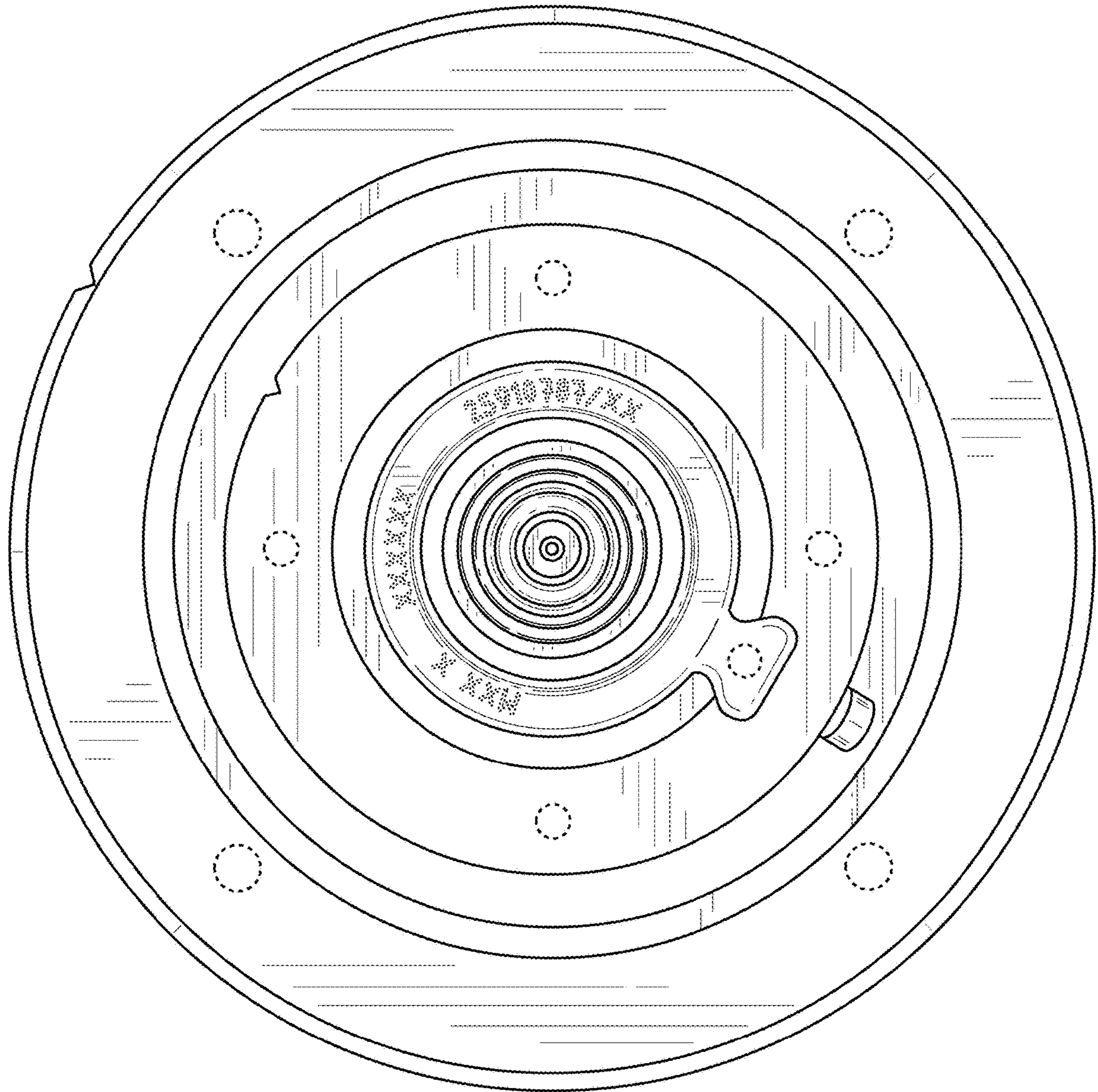

FIG. 2

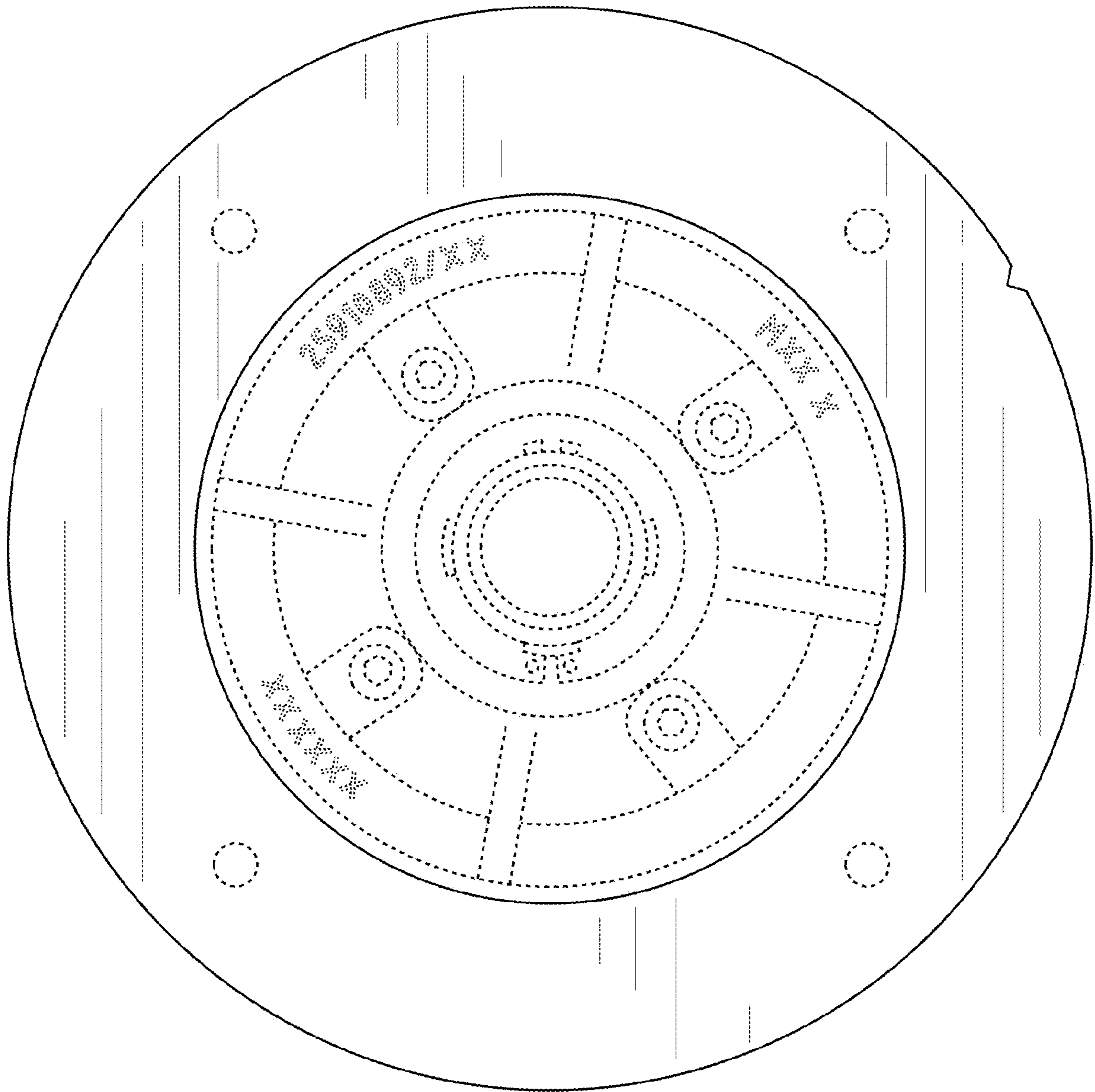

FIG. 3

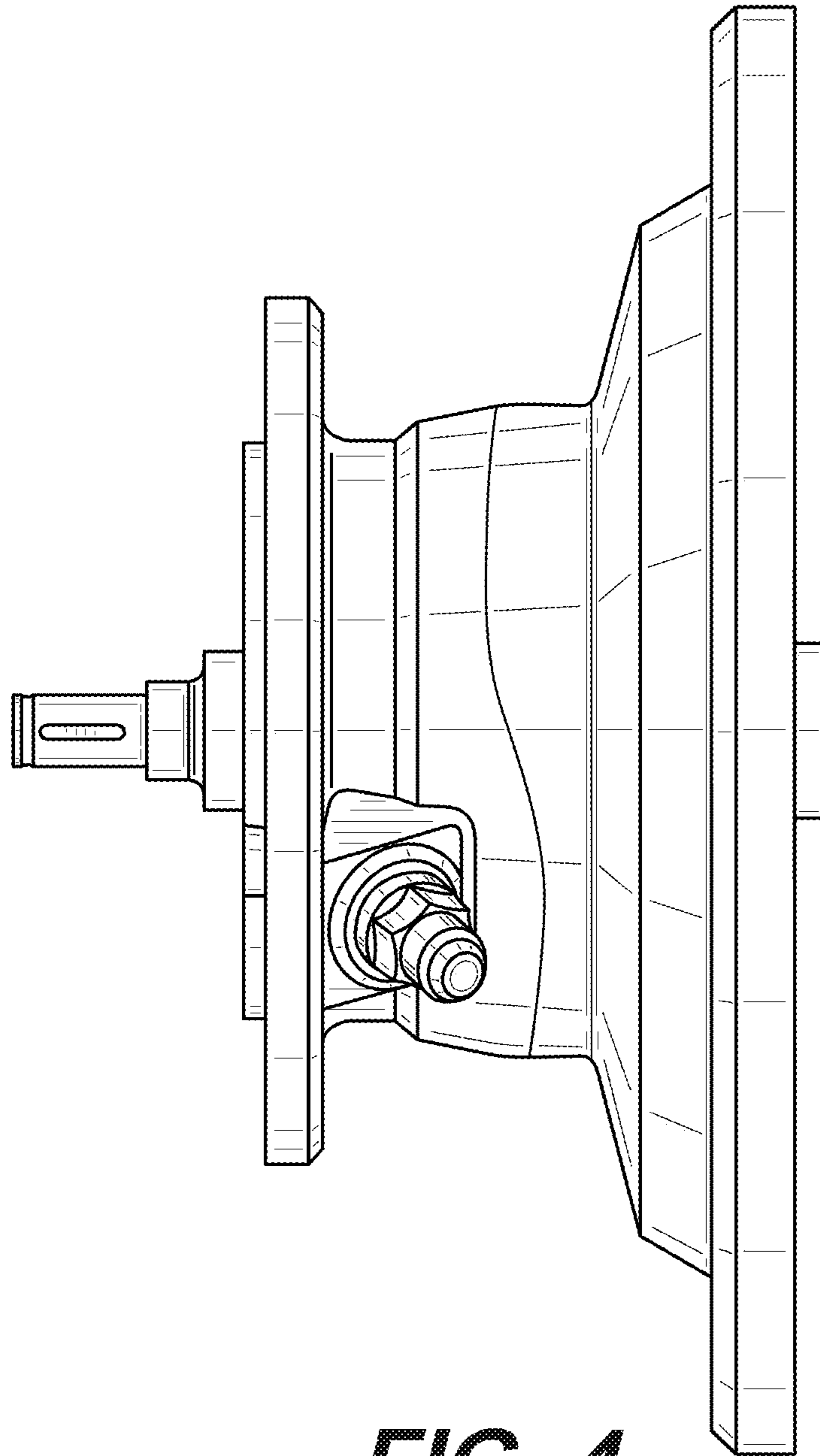

FIG. 4

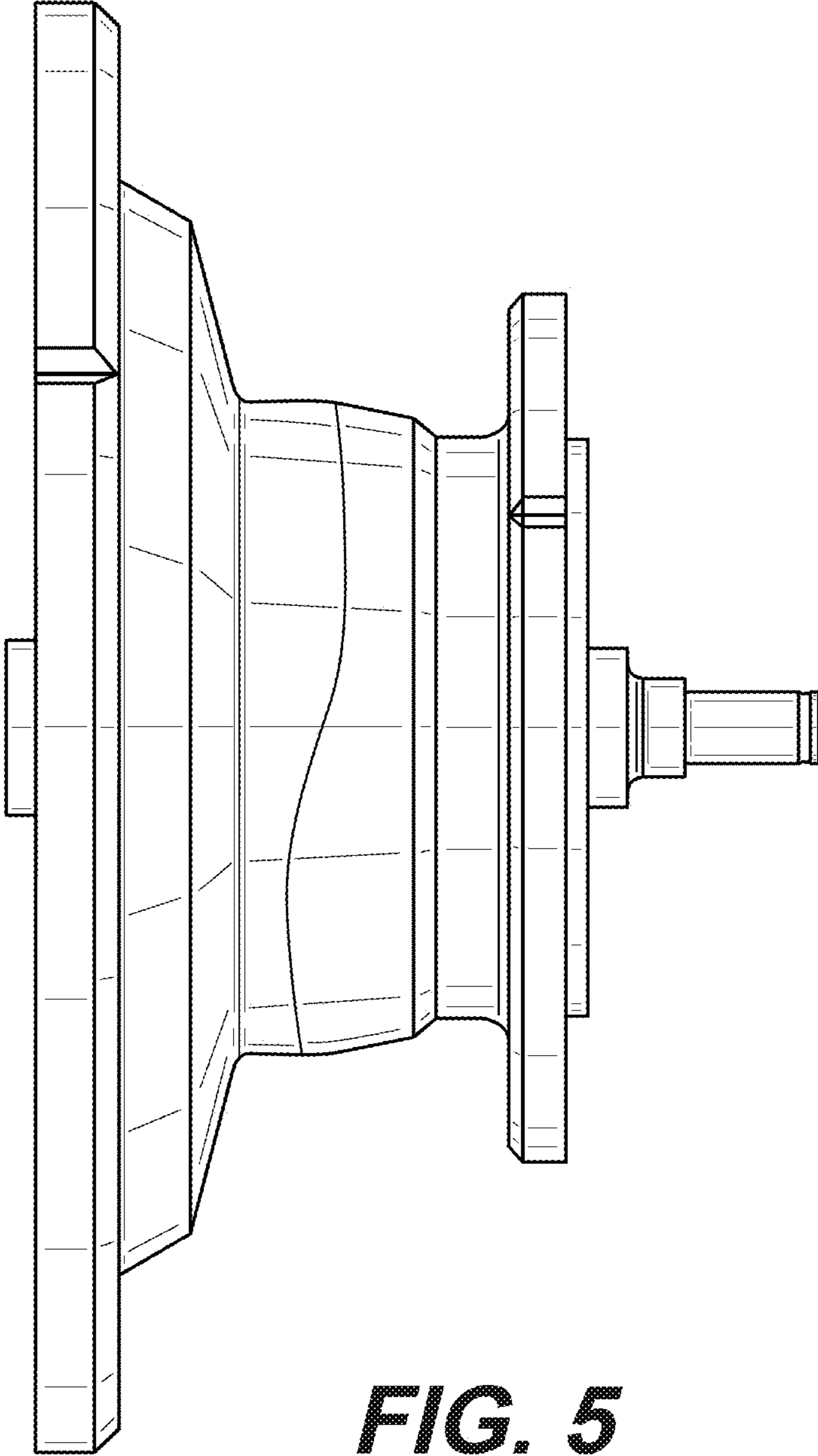

FIG. 5

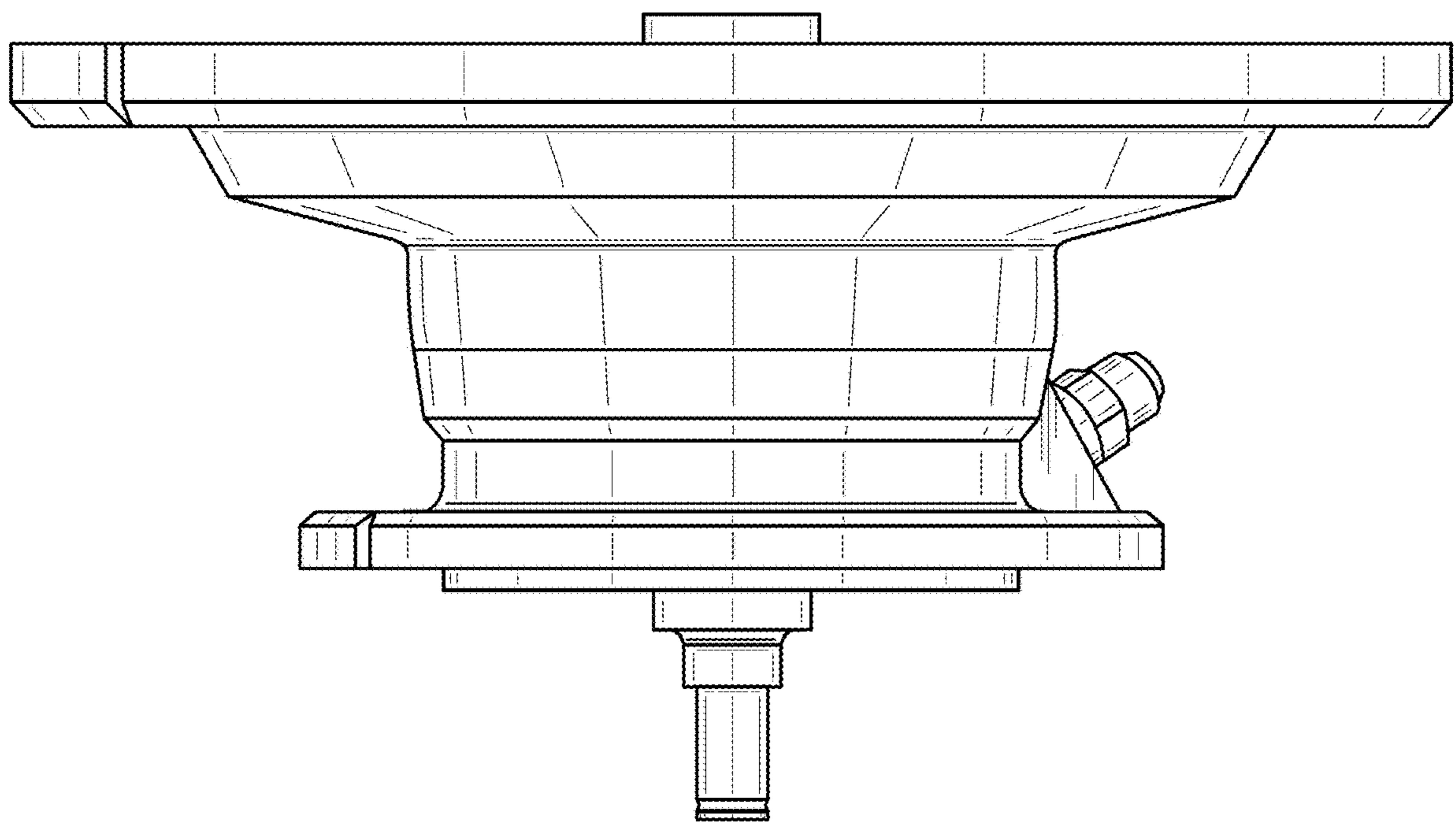

FIG. 6

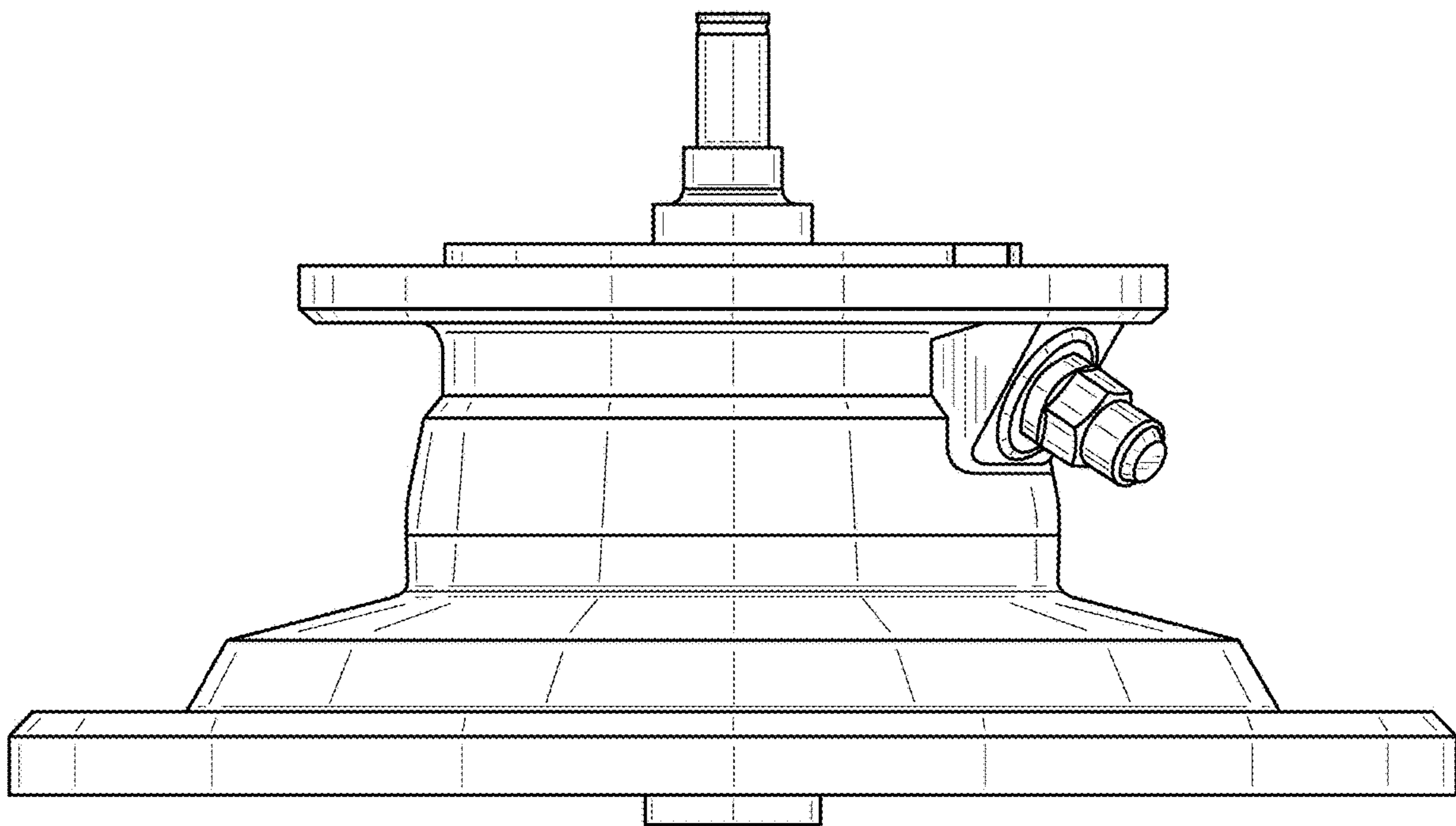

FIG. 7