



US00D975596S

(12) **United States Design Patent**
Lambri et al.

(10) **Patent No.:** **US D975,596 S**
(45) **Date of Patent:** **** Jan. 17, 2023**

(54) **MOTOR SCOOTER**

(71) Applicant: **PIAGGIO & C S.p.A.**, Pontedera (IT)

(72) Inventors: **Marco Lambri**, Pontedera (IT); **Davide Cattaneo**, Pontedera (IT)

(73) Assignee: **PIAGGIO & C S.p.A.**, Pontedera (IT)

(**) Term: **15 Years**

(21) Appl. No.: **29/783,702**

(22) Filed: **May 14, 2021**

(51) **LOC (14) Cl.** **12-11**

(52) **U.S. Cl.**
USPC **D12/110**

(58) **Field of Classification Search**
USPC D12/110, 111, 117; D21/432, 538
CPC B62K 11/00; B62K 11/02; B62K 11/04;
B62K 11/10; B62K 17/00; B62K 19/00;
B62K 2202/00

See application file for complete search history.

(56) **References Cited**

U.S. PATENT DOCUMENTS

4,487,283	A	*	12/1984	Suzuki	B62J 35/00
						180/68.5
4,715,465	A	*	12/1987	Takahashi	B62J 17/10
						180/219
D475,950	S	*	6/2003	Kawano	D12/110
D490,750	S	*	6/2004	Hoshino	D12/110
D503,908	S	*	4/2005	Tomomatsu	D12/110
D610,490	S	*	2/2010	Wong	D12/110
D622,636	S	*	8/2010	Cheng	D12/110
D622,637	S	*	8/2010	Schneider	D12/110
D632,227	S	*	2/2011	Lambri	D12/110
D642,497	S	*	8/2011	Lin	D12/110
D643,782	S	*	8/2011	Maccioni	D12/110
D644,570	S	*	9/2011	Chuang	D12/110
D647,006	S	*	10/2011	Hung	D12/110

D654,402	S	*	2/2012	Lambri	D12/110
D664,898	S	*	8/2012	Van Hooydonk	D12/110
D669,395	S	*	10/2012	Lambri	D12/110
D669,396	S	*	10/2012	Sawatsutipan	D12/110
D673,882	S	*	1/2013	Tartarini	D12/110
D678,128	S	*	3/2013	Lambri	D12/110
D678,129	S	*	3/2013	Kubota	D12/110
D680,911	S	*	4/2013	Wu	D12/110
D697,835	S	*	1/2014	Kito	D12/110
D726,076	S	*	4/2015	Arai	D12/110

(Continued)

OTHER PUBLICATIONS

Sabrina Giacomini. "Yamaha and Gogoro Team Up To Build Battery-Swapping e-Scooter." Ride Apart., Sep. 14, 2018 [online] , [retrieved on Aug. 26, 2022]. Retrieved from the Internet <URL: <https://www.rideapart.com/news/266129/yamaha-gogoro-battery-swap-scooter/>>.*

(Continued)

Primary Examiner — Darlington Ly
(74) *Attorney, Agent, or Firm* — Ferguson Case Orr Paterson

(57) **CLAIM**

The ornamental design for a motor scooter, as shown and described.

DESCRIPTION

FIG. 1 is a front and left side perspective view of a motor scooter embodying our new design;
FIG. 2 is a front elevation view thereof;
FIG. 3 is a rear elevation view thereof;
FIG. 4 is a left side elevation view thereof;
FIG. 5 is a right side elevation view thereof;
FIG. 6 is a top plan view thereof;
FIG. 7 is a rear and right side perspective view thereof; and,
FIG. 8 is a bottom plan view thereof.

1 Claim, 8 Drawing Sheets



(56)

References Cited

U.S. PATENT DOCUMENTS

D727,799 S * 4/2015 Castrucci D12/110
9,216,787 B2 * 12/2015 Duncan B62J 43/23

OTHER PUBLICATIONS

Taiwan Today. “Gogoro sets company record with preorders of new series.” Taiwan Times., Jul. 12, 2017 [online], [retrieved on Aug. 26, 2022]. Retrieved from the Internet <URL: <https://www.taiwannews.com.tw/en/news/3208661>>.*

Guy Salens. “Quadro Vehicles presents their electric scooter Oxygen.” Electric Motorcycles News., Jun. 22, 2019 [online], [retrieved on Aug. 26, 2022]. Retrieved from the Internet <URL: <https://electricmotorcycles.news/quadro-vehicles-presents-their-electric-scooter-oxygen/>>.*

“Vespa Gts—2019 Product Book.” Piaggio., Dec. 5, 2018 [online], [retrieved on Aug. 26, 2022]. Retrieved from the Internet <URL: <https://www.piaggio.rs/wp-content/uploads/2019/06/GTS-SVI-MQDELI-1.pdf>>.*

“Piaggio—Urban Life—2022 Range.” Piaggio., Nov. 22, 2021 [online], [retrieved on Aug. 26, 2022]. Retrieved from the Internet <URL: <https://api.spgnordic.com/wp-content/uploads/2021/06/Piaggio-range-2022.pdf>>.*

* cited by examiner



FIG. 1

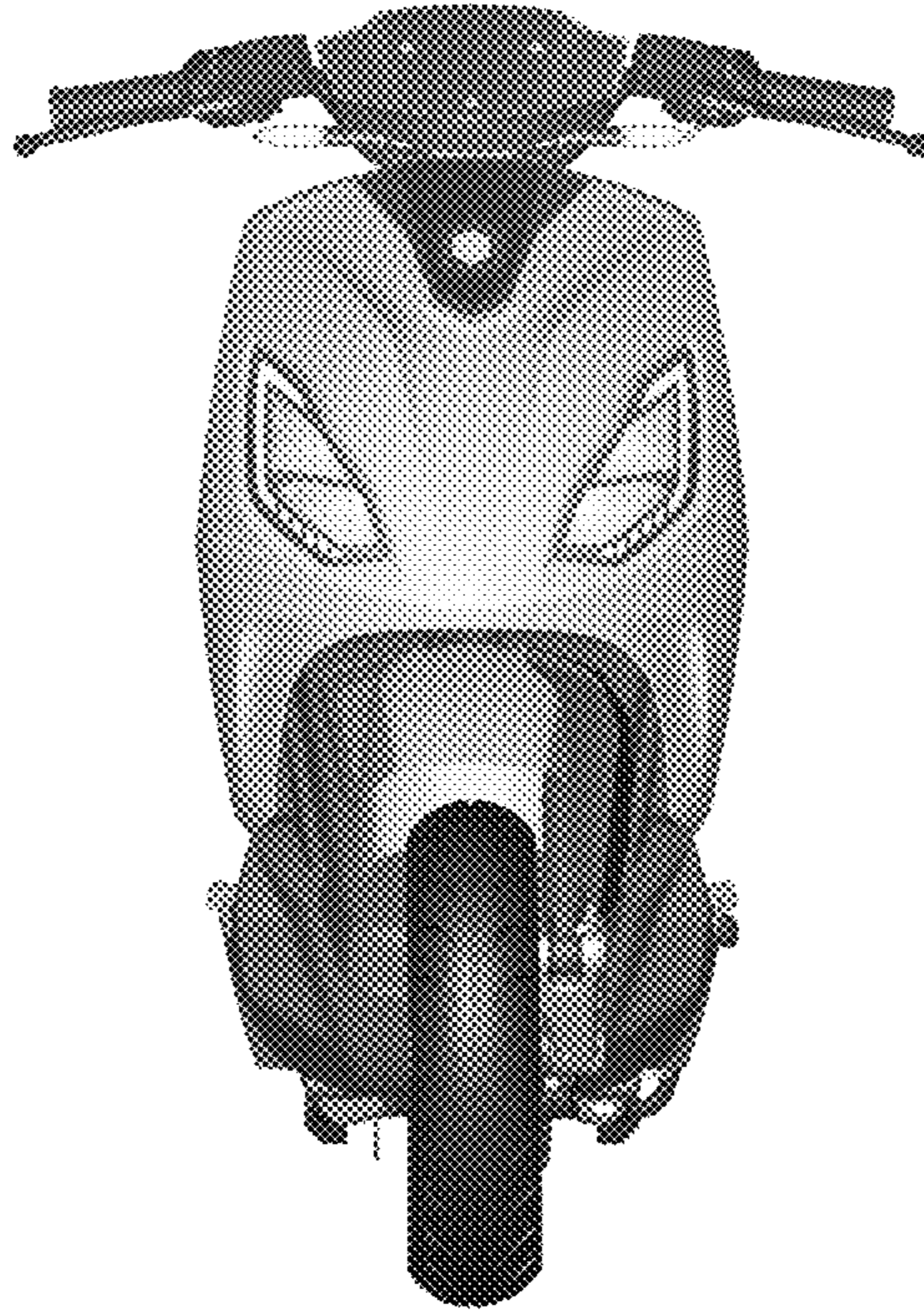

FIG. 2

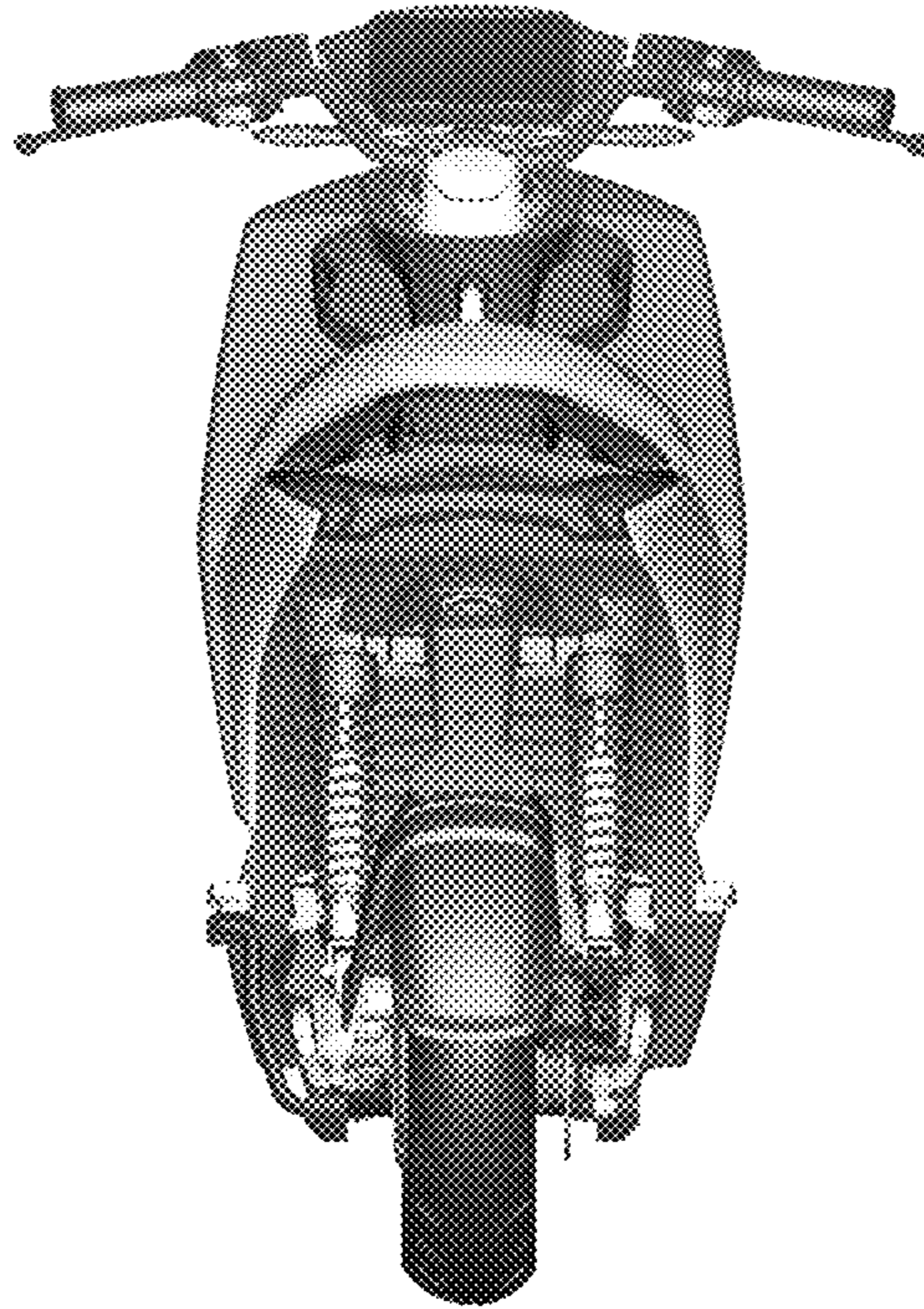

FIG. 3



FIG. 4



FIG. 5

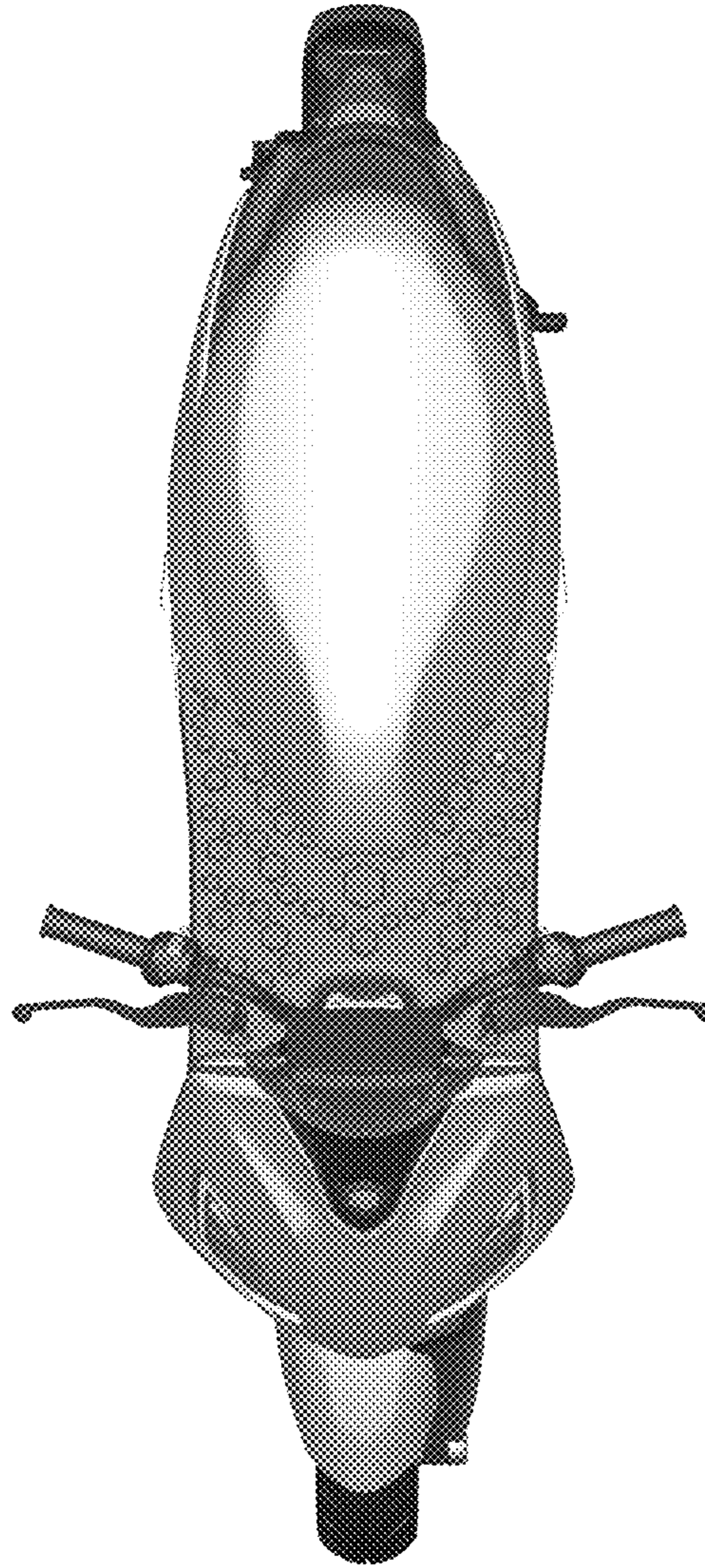

FIG. 6



FIG. 7

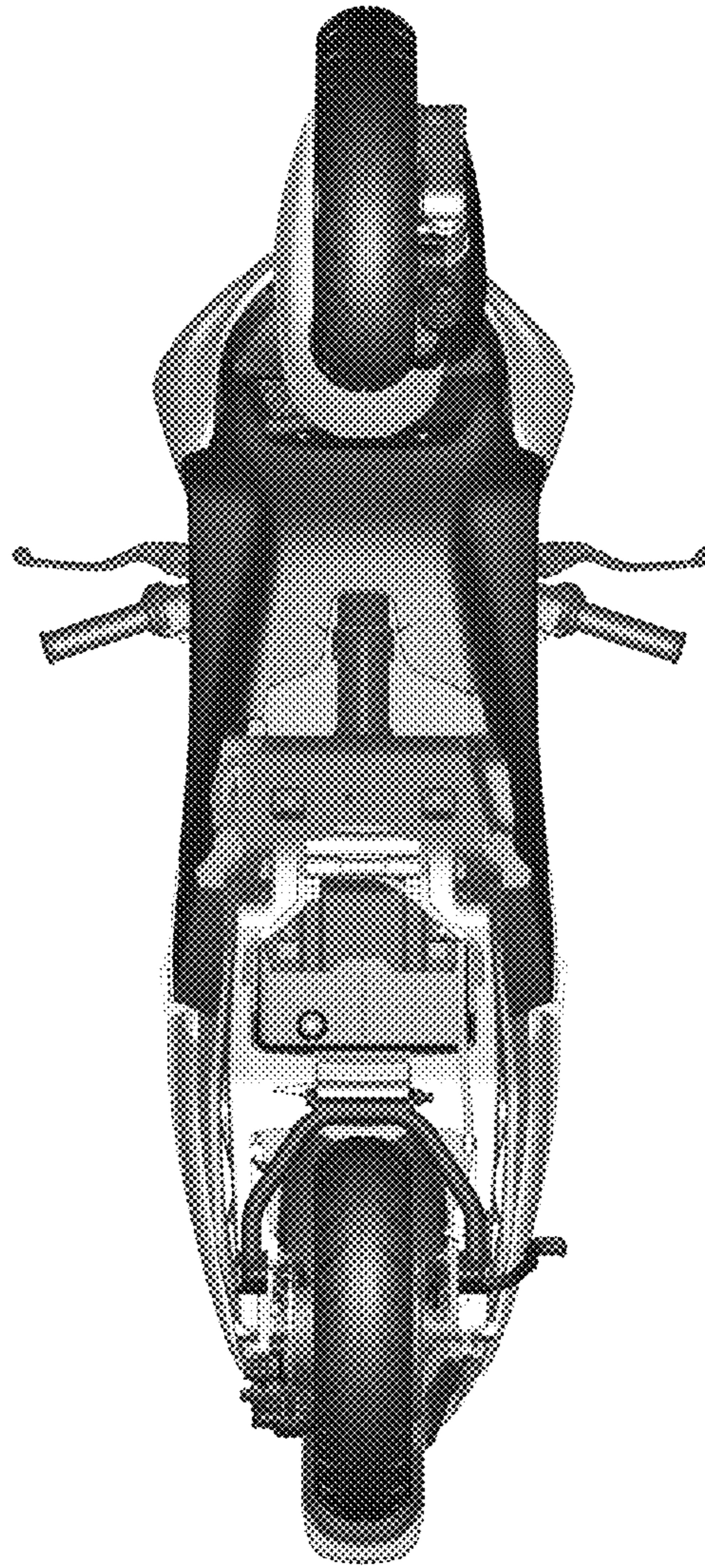

FIG. 8