



US00D975592S

(12) **United States Design Patent**
Kupitza

(10) **Patent No.:** **US D975,592 S**

(45) **Date of Patent:** **** Jan. 17, 2023**

- (54) **MOTOR TRUCK CAB PART**
- (71) Applicant: **MAN Truck & Bus SE**, Munich (DE)
- (72) Inventor: **Rudolf Kupitza**, Munich (DE)
- (73) Assignee: **MAN TRUCK & BUS SE**, Munich (DE)

- D416,829 S 11/1999 Sacco et al.
- D422,944 S 4/2000 Hellhake et al.
- D425,826 S 5/2000 Hellhake et al.
- D442,519 S * 5/2001 Sacco D12/96
- 6,230,832 B1 5/2001 von Mayenburg et al.
- D540,218 S * 4/2007 Sekiguchi D12/96
- D540,219 S 4/2007 Oka

(Continued)

- (**) Term: **15 Years**
- (21) Appl. No.: **29/807,511**
- (22) Filed: **Sep. 13, 2021**

OTHER PUBLICATIONS

“Simplifying Business.” Man Truckbus Asia., May 27, 2020 [online], [retrieved on Oct. 9, 2022]. Retrieved from the Internet <URL: <http://www.man-truckbus-asia.com/pdf/Company%20Profile%20MAN.pdf>>.*

(Continued)

Related U.S. Application Data

- (62) Division of application No. 35/509,887, filed on Nov. 26, 2019 (U.S. filing date under 35 U.S.C. 384), and having an international filing date of Nov. 26, 2019, now Pat. No. Des. 933,532.

Primary Examiner — Darlington Ly
(74) *Attorney, Agent, or Firm* — Fox Rothschild LLP

Foreign Application Priority Data

- (30) Jun. 6, 2019 (DE) 40 2019 100 633.8
- (51) **LOC (14) Cl.** **12-08**
- (52) **U.S. Cl.**
USPC **D12/96**; D12/84; D12/195
- (58) **Field of Classification Search**
USPC ... D12/1, 14, 15, 82, 84, 90, 93, 95, 96, 99;
D21/433, 434, 552, 554
CPC B60Y 2200/14; B60Y 2200/141; B60Y
2200/142; B60Y 2200/1422; B62D 33/00;
B62D 33/06; B62D 33/077; B62D
33/0604; B62D 33/0612
See application file for complete search history.

(57) **CLAIM**

The ornamental design for a motor truck cab part, as shown and described.

DESCRIPTION

FIG. 1 is a left side elevation view of a motor truck cab part embodying my new design;
FIG. 2 is a right side elevation view thereof;
FIG. 3 is a right side elevation view thereof;
FIG. 4 is a rear side elevation view thereof;
FIG. 5 is a bottom plan view thereof;
FIG. 6 is a top plan view thereof;
FIG. 7 is a left side elevation perspective view thereof;
FIG. 8 is a rear perspective view thereof; and,
FIG. 9 is a left side elevation perspective view thereof in the context of a motor truck.
The broken lines and ghosted or low contrasted showings of the motor truck interior are provided for the purpose of illustrating environmental structure and form no part of the claimed design.

(56) **References Cited**
U.S. PATENT DOCUMENTS

- 2,699,223 A 1/1955 Brumbaugh
- D276,710 S 12/1984 Brunger et al.
- 4,972,913 A 11/1990 Ray et al.

1 Claim, 9 Drawing Sheets

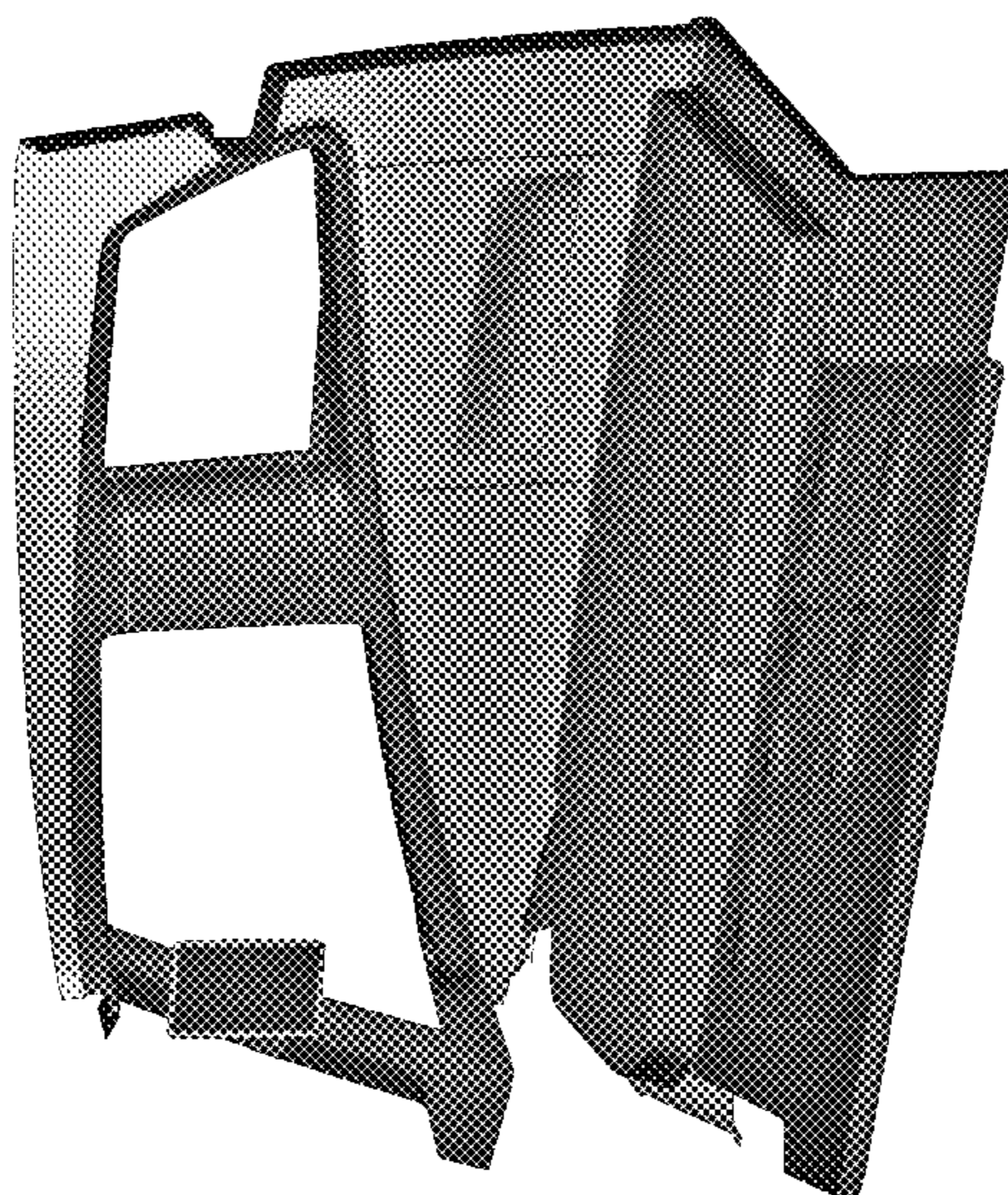

(56)

References Cited

U.S. PATENT DOCUMENTS

D567,885 S 4/2008 Amadio et al.
 D570,740 S * 6/2008 Emoto D12/96
 D571,259 S * 6/2008 Emoto D12/96
 D619,049 S * 7/2010 Beigel D12/96
 D623,091 S * 9/2010 Beigel D12/96
 D623,092 S * 9/2010 Beigel D12/96
 D632,614 S * 2/2011 Iuchi D12/96
 D634,244 S * 3/2011 Aris D12/96
 D642,205 S * 7/2011 Yamamoto D15/30
 D651,136 S * 12/2011 Stimel, Jr. D12/96
 D653,994 S * 2/2012 Fukushima D12/96
 D666,528 S * 9/2012 Lai D12/96
 D685,294 S 7/2013 Hanson et al.
 D687,868 S * 8/2013 Watson D15/30
 8,590,652 B2 11/2013 Grumbo
 D700,109 S 2/2014 Brzustowicz et al.
 D748,156 S * 1/2016 Koponen D15/30
 D813,728 S * 3/2018 Ito D12/93
 D817,229 S * 5/2018 Anderson D12/96
 D842,349 S * 3/2019 Kim D15/30
 D861,537 S * 10/2019 Lamanna D12/84
 D871,267 S * 12/2019 Armigliato D12/93
 D899,972 S * 10/2020 Lamanna D12/195
 D912,578 S * 3/2021 Egger D12/96
 D933,532 S * 10/2021 Kupitza D12/93
 D944,124 S * 2/2022 Spada B62D 25/06
 D955,295 S * 6/2022 Schwartz D12/96

2013/0202395 A1 8/2013 Levi
 2020/0259143 A1 * 8/2020 Sloan B60L 50/66
 2021/0268865 A1 * 9/2021 Saroka B60H 1/32284
 2022/0105791 A1 * 4/2022 Hendriks B60K 1/00

OTHER PUBLICATIONS

“That’s No Van. That’s a Man.” Man Truck & Bus., Jun. 2, 2021 [online], [retrieved on Oct. 9, 2022]. Retrieved from the Internet <URL: https://www.man.eu/ntg_media/media/en/content_medien/doc/bw_master/van_1/man_tge_product_catalogue.pdf>.*
 “2008 Man TGM.” Top Speed., Mar. 12, 2012 [online], [retrieved on Oct. 9, 2022]. Retrieved from the Internet <URL: <https://www.topspeed.com/trucks/truck-reviews/man/2008-man-tgm/>>.*
 Hall-Geisler, “Nikola Motor Company unveils its electric (mostly) truck.” Tech Crunch., May 19, 2016 [online], [retrieved on Sep. 1, 2021]. Retrieved from the Internet <URL: <https://techcrunch.com/2016/05/19/nikola-motor-company-unveils-its-electric-mostly-truck/>>.*
 Saleem, “Hyzon Motors Is Ready To Exploit Its First-Mover Advantage . . .” WCCF Tech., May 18, 2021 [online], [retrieved on Sep. 1, 2021]. Retrieved from the Internet <URL: <https://wccftech.com/hyzon-motors-is-ready-to-exploit-its-first-mover-advantage-by-launching-hydrogen-fuel-cell-powered-co>>.*
 “Top 10 Chinese Heavy-duty Truck Manufacturers.” Car Logos., Jul. 1, 2021 [online], [retrieved on Sep. 1, 2021]. Retrieved from the Internet <URL: <https://www.carlogos.org/reviews/chinese-heavy-duty-truck-manufacturers.html>>.*

* cited by examiner

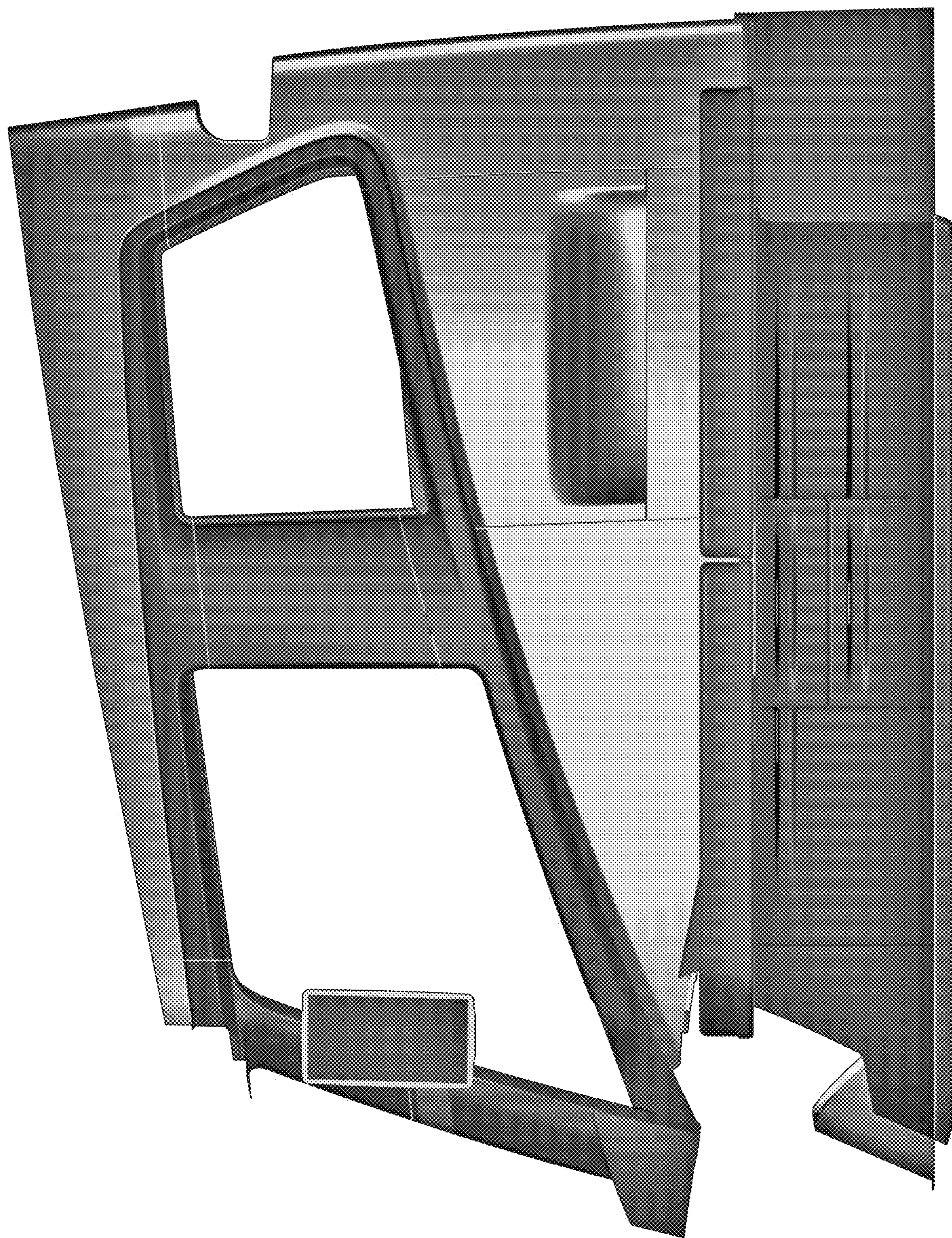

FIG. 1



FIG. 2

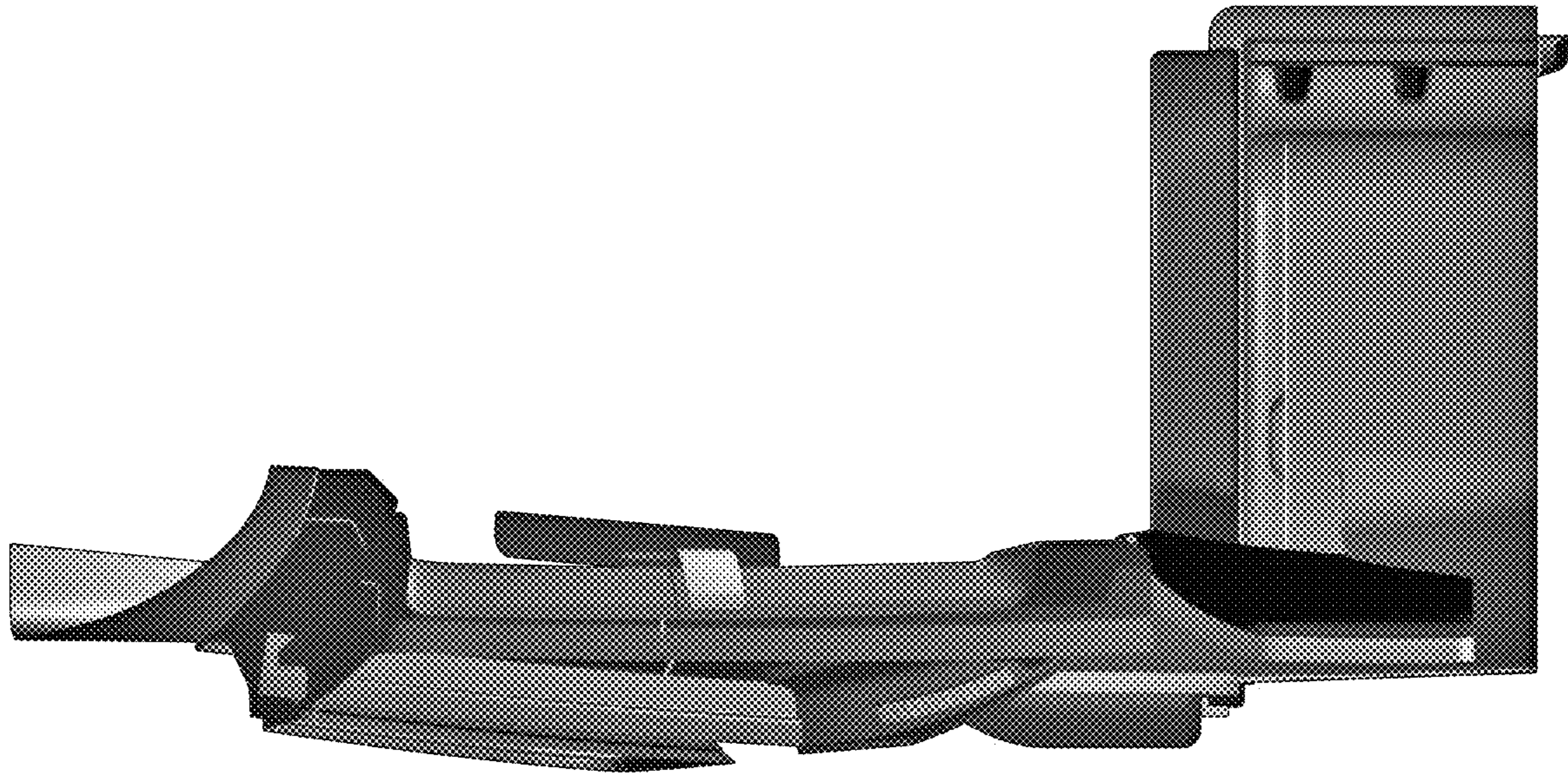

FIG. 3

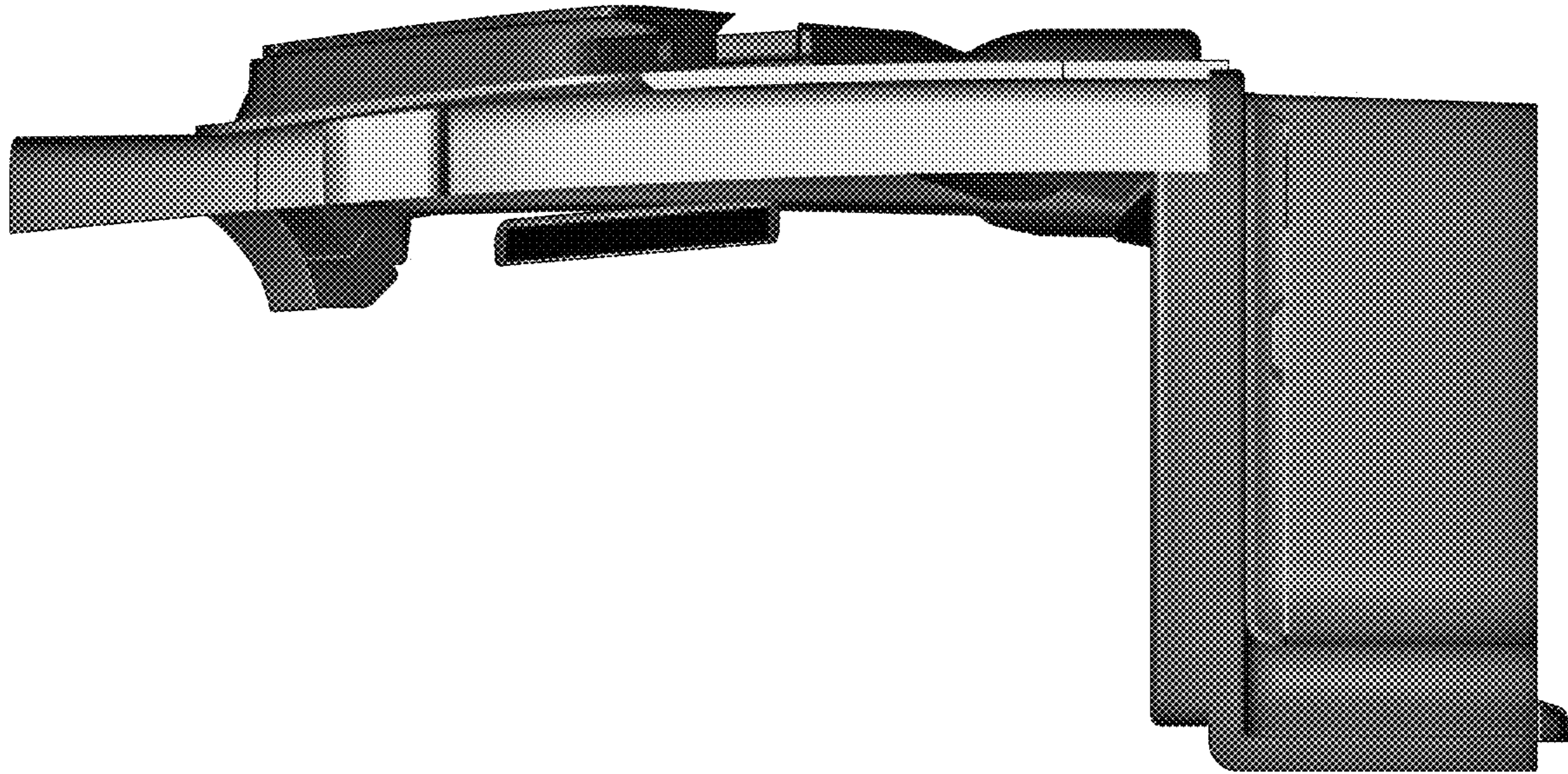

FIG. 4



FIG. 5

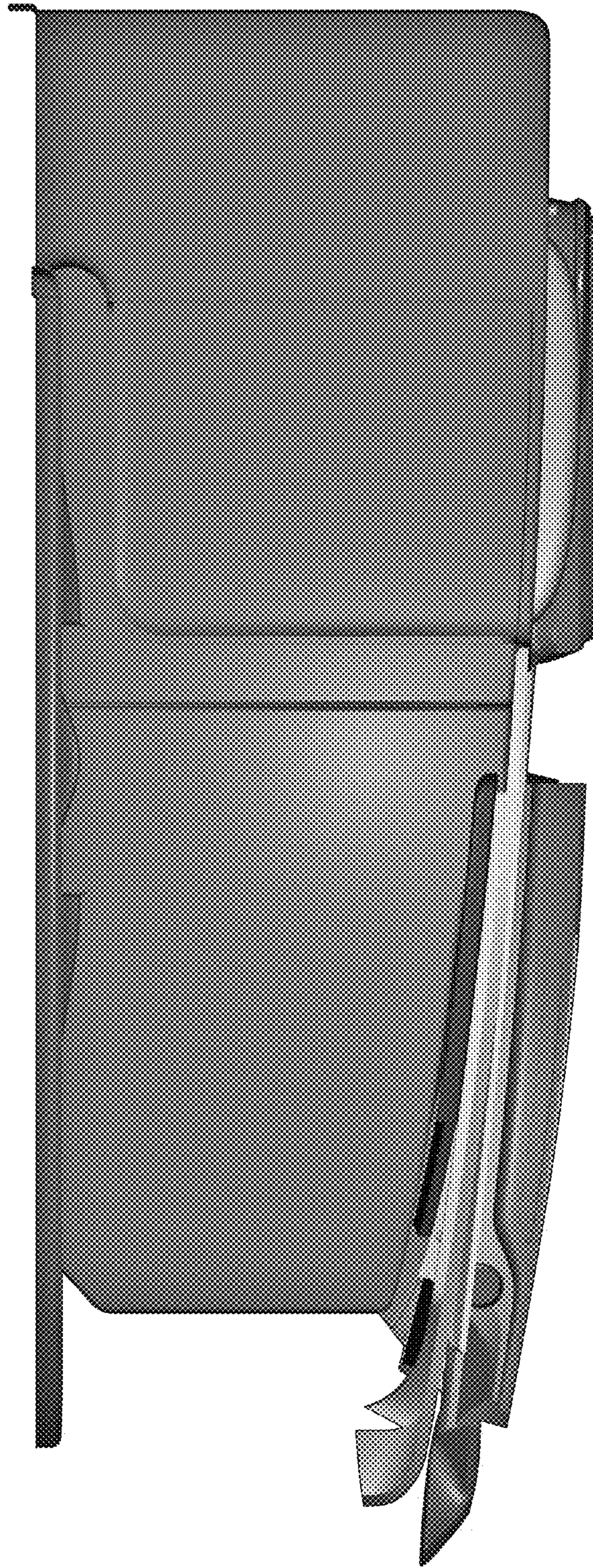

FIG. 6

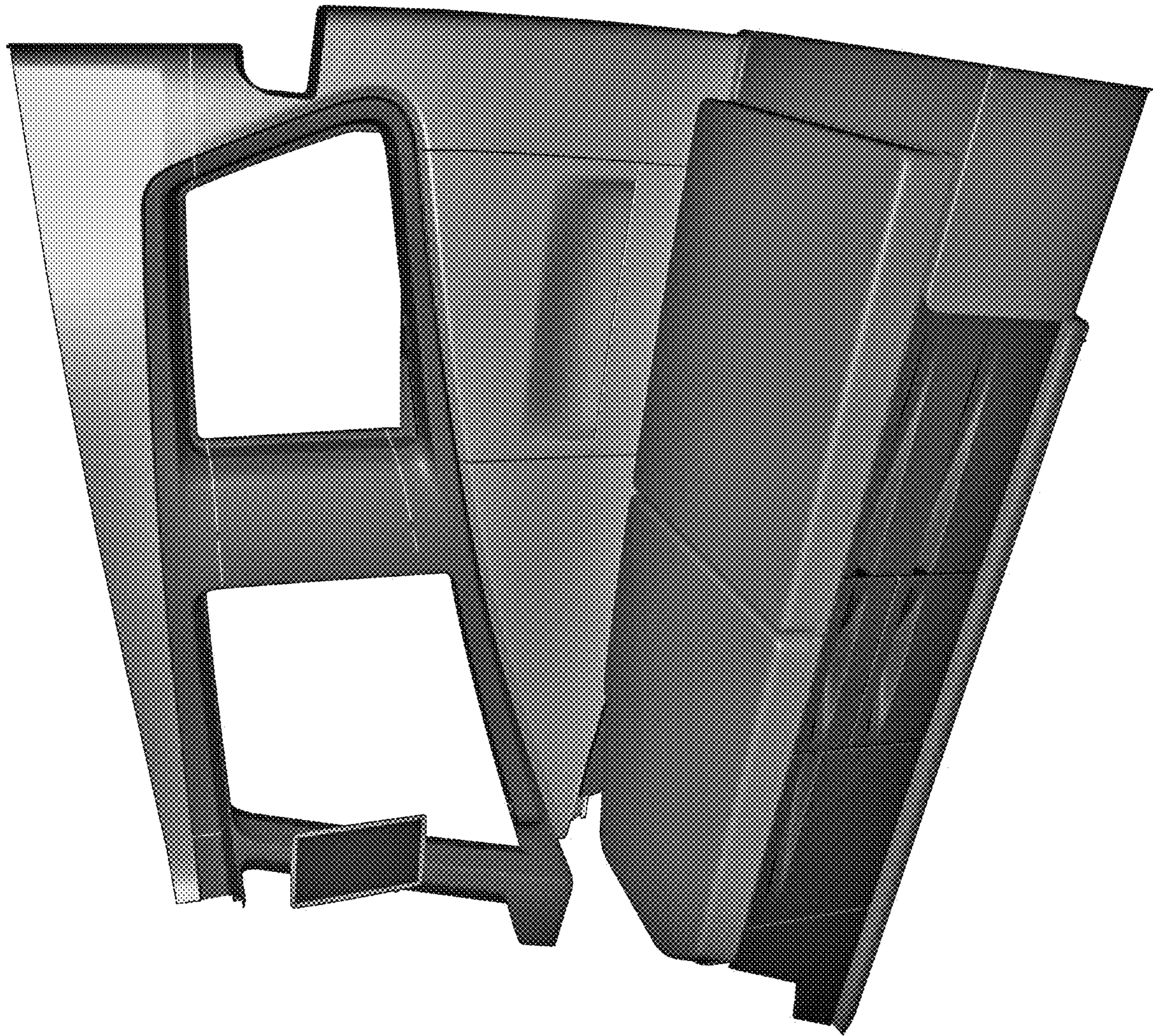

FIG. 7

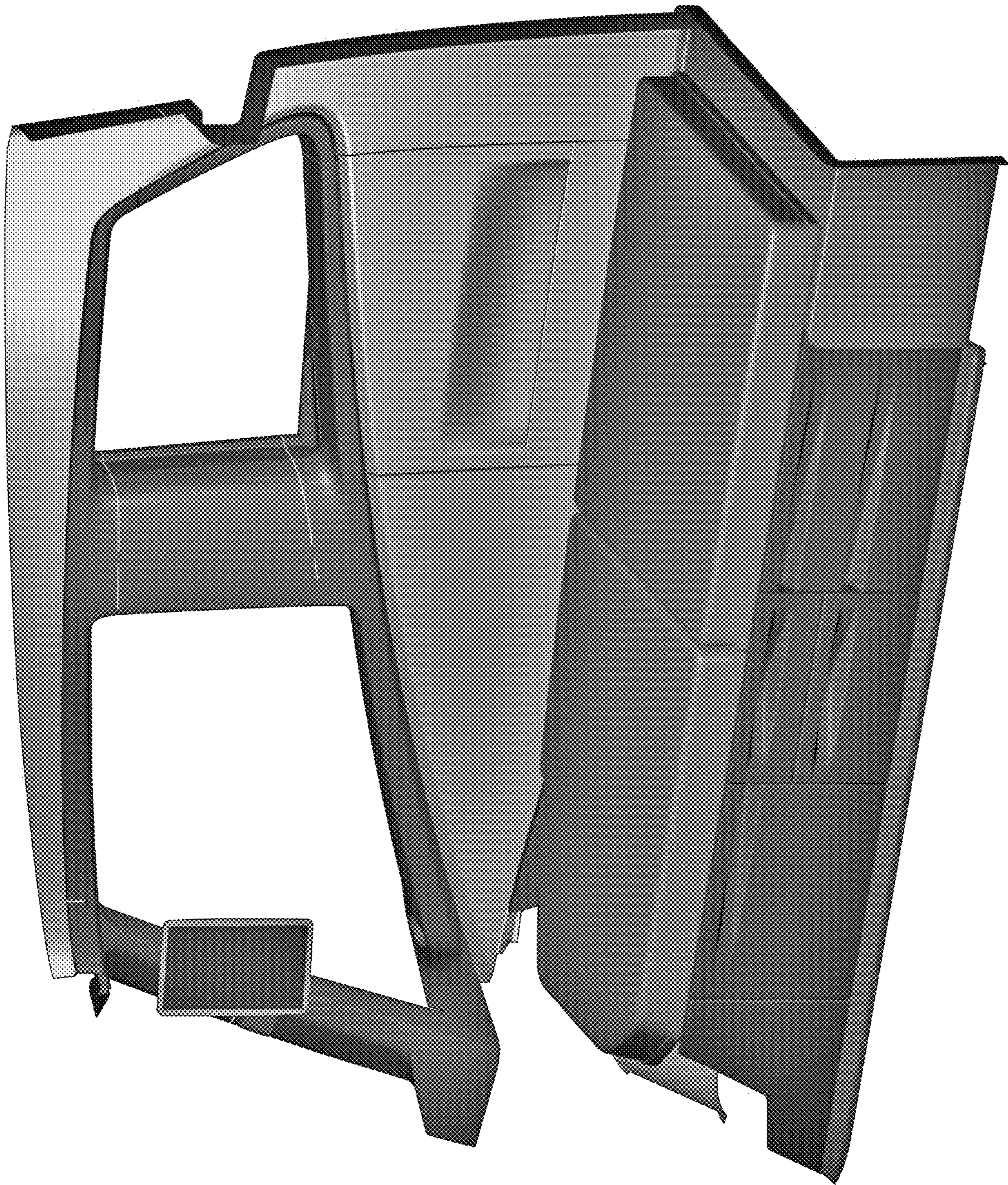

FIG. 8

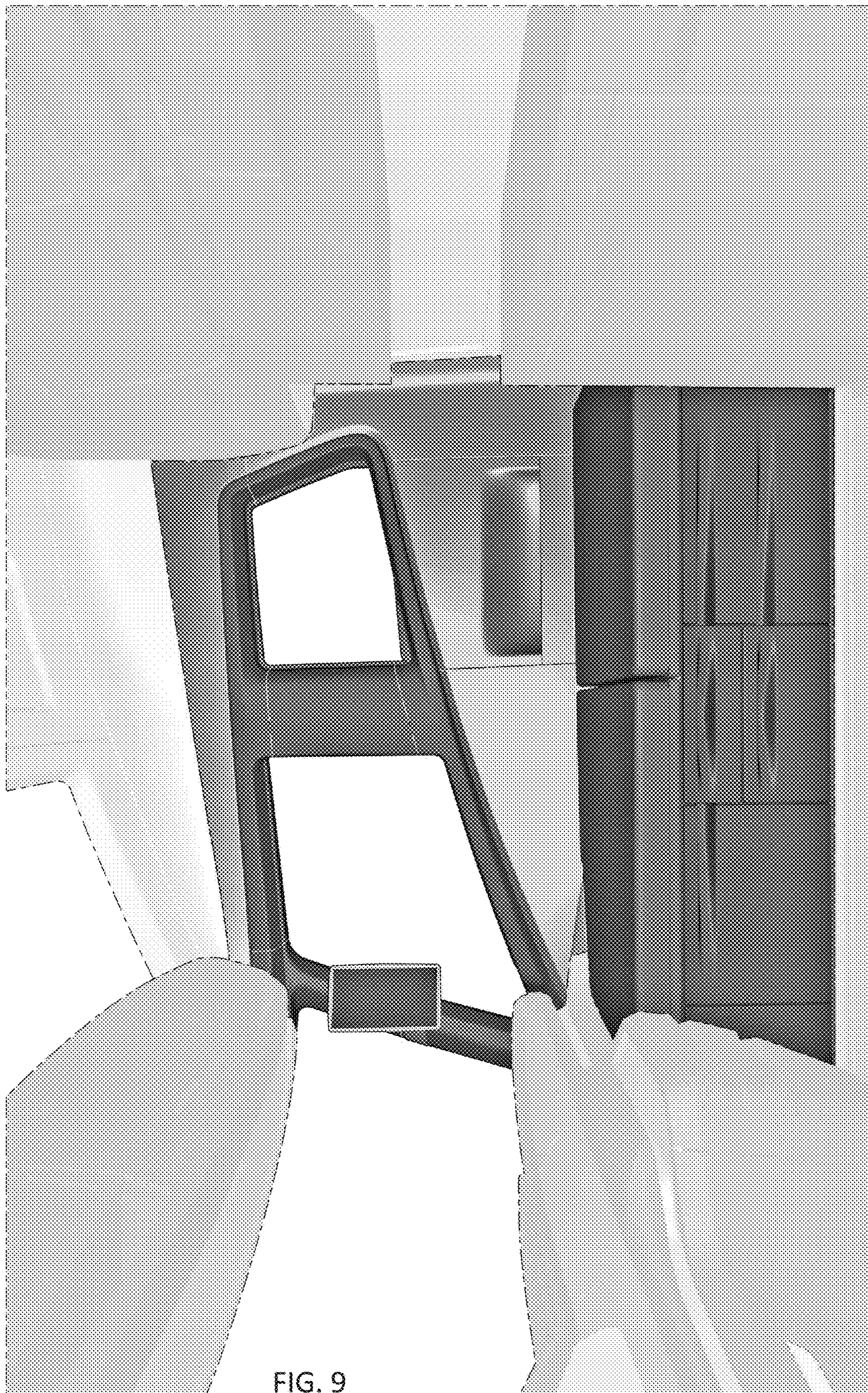

FIG. 9