



US00D975278S

(12) **United States Design Patent**
Shelton, IV et al.

(10) **Patent No.:** **US D975,278 S**
(45) **Date of Patent:** **** Jan. 10, 2023**

(54) **STAPLE CARTRIDGE**

(71) Applicant: **Ethicon LLC**, Guaynabo, PR (US)
(72) Inventors: **Frederick E. Shelton, IV**, Hillsboro, OH (US); **Jason L. Harris**, Lebanon, OH (US)
(73) Assignee: **Cilag GmbH International**, Zug (CH)
(**) Term: **15 Years**
(21) Appl. No.: **29/736,651**
(22) Filed: **Jun. 2, 2020**
(51) **LOC (14) Cl.** **24-02**
(52) **U.S. Cl.**
USPC **D24/145**

(58) **Field of Classification Search**
USPC D6/522, 523, 525, 526, 553, 566; D8/49, D8/51, 52, 59, 60, 64, 82, 85, 86, 95, 97, D8/300, 303, 349, 499; D14/372; D15/138, 139; D16/100, 130, 309; D24/108, 112, 113, 114, 115, 119, 127, D24/128, 129, 130, 133, 137, 142, 144, D24/145, 146, 147, 148, 150, 155, 158, D24/160, 170, 171, 172, 173, 181, 185, D24/186, 188, 200, 215, 216, 222, 231, D24/232; D25/38.1, 41.1; D10/57; D28/7
CPC A61B 3/00; A61B 3/0016; A61B 3/0025; A61B 3/0033; A61B 3/0041; A61B 3/0075; A61B 3/0083; A61B 3/0091; A61B 3/02; A61B 3/10; A61B 3/1005; A61B 3/12;

(Continued)

(56) **References Cited**

U.S. PATENT DOCUMENTS

66,052 A 6/1867 Smith
662,587 A 11/1900 Blake

(Continued)

FOREIGN PATENT DOCUMENTS

AU 2012200594 A1 2/2012
AU 2012203035 A1 6/2012

(Continued)

OTHER PUBLICATIONS

Science Direct, "Laparoscopic linear cutting stapler failure", first available Sep. 2002. (<https://www.sciencedirect.com/science/article/pii/S0090429502017788>) (Year: 2002).*

(Continued)

Primary Examiner — Lauren D McVey
Assistant Examiner — Justin A Johnson

(57) **CLAIM**

The ornamental design for a staple cartridge, as shown and described.

DESCRIPTION

FIG. 1 is a perspective view of a staple cartridge, showing our new design without surface shading;
FIG. 2 is a top plan view thereof;
FIG. 3 is a bottom plan view thereof;
FIG. 4 is a right-side elevational thereof;
FIG. 5 is left-side elevational view thereof;
FIG. 6 is a front elevational view thereof;
FIG. 7 is a rear elevational view thereof;
FIG. 8 is a perspective view of a staple cartridge, showing our new design with surface shading;
FIG. 9 is a top plan view thereof;
FIG. 10 is a bottom plan view thereof;
FIG. 11 is a right-side elevational view thereof;
FIG. 12 is left-side elevational view thereof;
FIG. 13 is a front elevational view thereof; and,
FIG. 14 is a rear elevational view thereof.
The broken lines in the drawings illustrate portions of the staple cartridge and form no part of the claimed design.

1 Claim, 8 Drawing Sheets

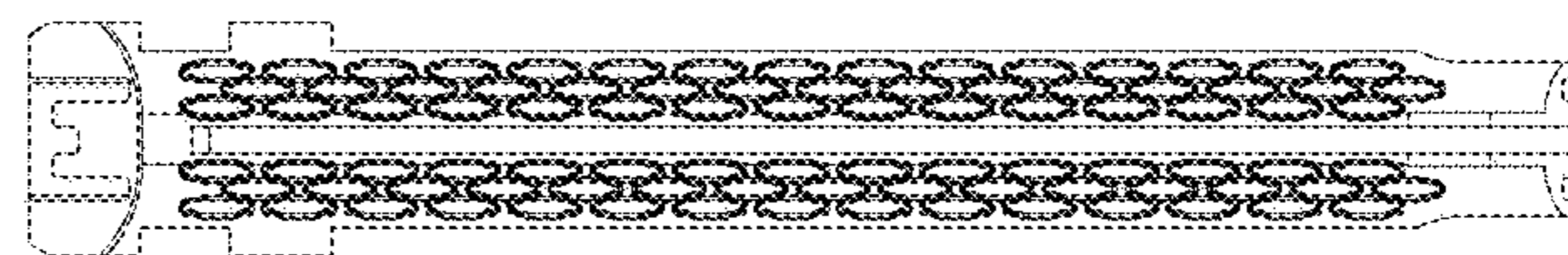
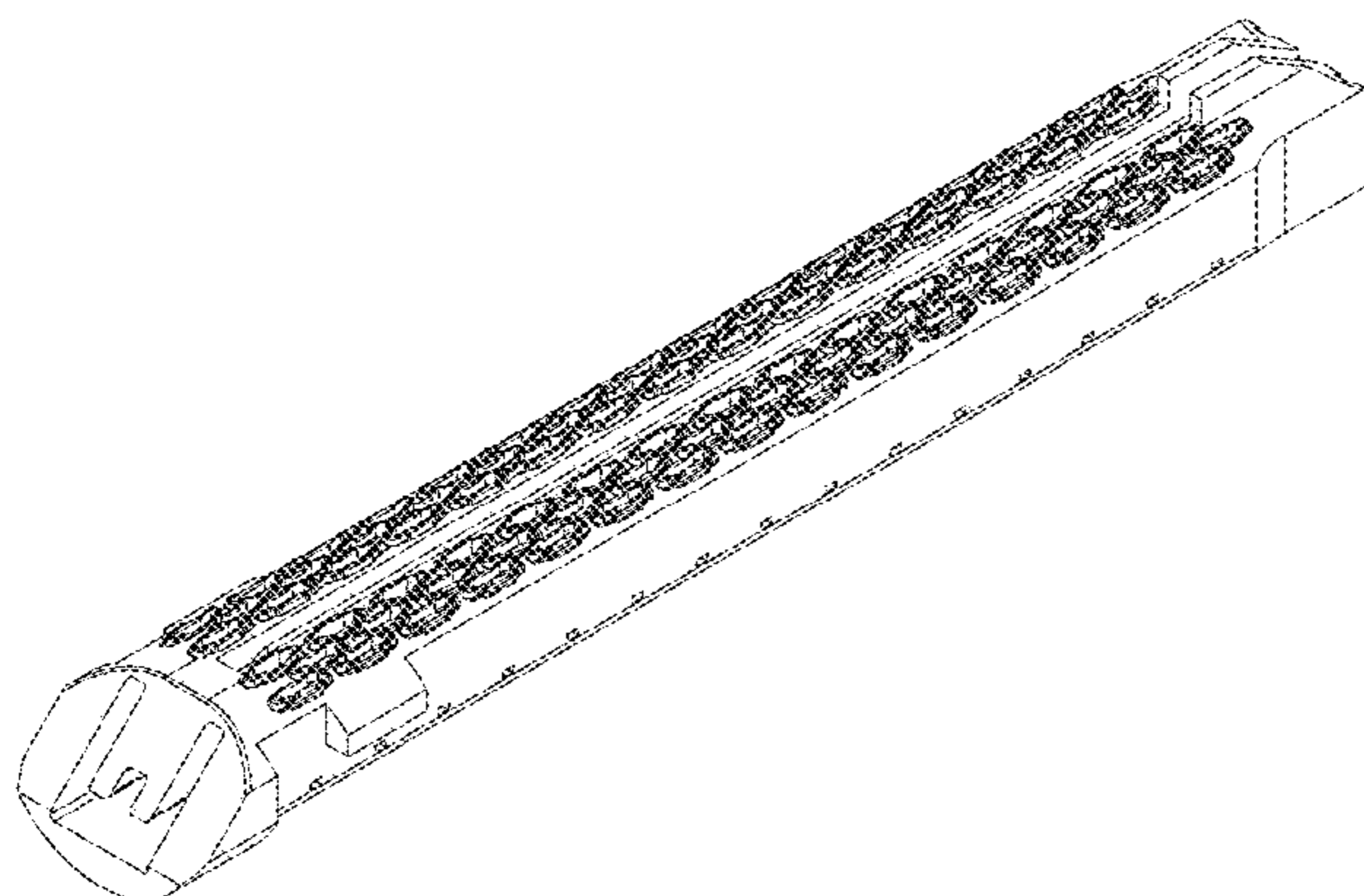

(58) Field of Classification Search

CPC .. A61B 3/13; A61B 3/18; A61B 17/00; A61B 2017/00349; A61B 2017/00455; A61B 2017/00464; A61B 2017/00473; A61B 2017/0053; A61B 17/0057; A61B 17/0231; A61B 17/04; A61B 17/064; A61B 17/0642; A61B 17/0643; A61B 17/0644; A61B 2017/0688; A61B 17/14; A61B 17/142; A61B 17/15; A61B 17/151; A61B 17/154; A61B 17/155; A61B 17/157; A61B 17/158; A61B 17/16; A61B 17/1613; A61B 17/1615; A61B 17/1617; A61B 2090/0817; A61B 2017/00663; A61B 17/0401; A61B 2017/0404; A61B 10/00; A61B 10/02; A61B 2010/0208; A61B 10/04; A61B 2010/045; A61B 17/221; A61B 17/34; A61B 17/3415; B23D 51/025; A61F 9/00; A61F 9/007; A61F 9/0133; A61F 2210/0004; A61H 5/00; A61H 5/005; A61H 2205/022; E21B 10/00; B28B 7/00; B28B 7/0002; B28B 7/0032; B28B 7/0094; B28B 7/16; B28B 7/18

See application file for complete search history.

(56)

References Cited

U.S. PATENT DOCUMENTS

670,748 A	3/1901	Weddeler	2,804,848 A	9/1957	O'Farrell et al.
719,487 A	2/1903	Minor	2,808,482 A	10/1957	Zanichkowsky et al.
804,229 A	11/1905	Hutchinson	2,825,178 A	3/1958	Hawkins
903,739 A	11/1908	Lesemann	2,853,074 A	9/1958	Olson
951,393 A	3/1910	Hahn	2,856,192 A	10/1958	Schuster
1,075,556 A	10/1913	Fenoughty	2,887,004 A	5/1959	Stewart
1,082,105 A	12/1913	Anderson	2,957,353 A	10/1960	Lewis
1,188,721 A	6/1916	Bittner	2,959,974 A	11/1960	Emrick
1,306,107 A	6/1919	Elliott	3,026,744 A	3/1962	Rouse
1,314,601 A	9/1919	McCaskey	3,032,769 A	5/1962	Palmer
1,466,128 A	8/1923	Hallenbeck	3,035,256 A	5/1962	Egbert
1,677,337 A	7/1928	Grove	3,060,972 A	10/1962	Sheldon
1,794,907 A	3/1931	Kelly	3,075,062 A	1/1963	Iaccarino
1,849,427 A	3/1932	Hook	3,078,465 A	2/1963	Bobrov
1,944,116 A	1/1934	Stratman	3,079,606 A	3/1963	Bobrov et al.
1,954,048 A	4/1934	Jeffrey et al.	3,080,564 A	3/1963	Strekopitov et al.
2,028,635 A	1/1936	Wappler	3,166,072 A	1/1965	Sullivan, Jr.
2,037,727 A	4/1936	La Chapelle	3,180,236 A	4/1965	Beckett
2,120,951 A	6/1938	Hodgman	3,196,869 A	7/1965	Scholl
2,132,295 A	10/1938	Hawkins	3,204,731 A	9/1965	Bent et al.
2,161,632 A	6/1939	Nattenheimer	3,266,494 A	8/1966	Brownrigg et al.
D120,434 S	5/1940	Gold	3,269,630 A	8/1966	Fleischer
2,211,117 A	8/1940	Hess	3,269,631 A	8/1966	Takaro
2,214,870 A	9/1940	West	3,275,211 A	9/1966	Hirsch et al.
2,224,108 A	12/1940	Ridgway	3,315,863 A	4/1967	O'Dea
2,224,882 A	12/1940	Peck	3,317,103 A	5/1967	Cullen et al.
2,318,379 A	5/1943	Davis et al.	3,317,105 A	5/1967	Astafjev et al.
2,329,440 A	9/1943	La Place	3,357,296 A	12/1967	Lefever
2,377,581 A	6/1945	Shaffrey	3,359,978 A	12/1967	Smith, Jr.
2,406,389 A	8/1946	Lee	3,377,893 A	4/1968	Shorb
2,420,552 A	5/1947	Morrill	3,480,193 A	11/1969	Ralston
2,441,096 A	5/1948	Happe	3,490,675 A	1/1970	Green et al.
2,448,741 A	9/1948	Scott et al.	3,494,533 A	2/1970	Green et al.
2,450,527 A	10/1948	Smith	3,499,591 A	3/1970	Green
2,491,872 A	12/1949	Neuman	3,503,396 A	3/1970	Pierie et al.
2,507,872 A	5/1950	Unsinger	3,509,629 A	5/1970	Kidokoro
2,526,902 A	10/1950	Rubleee	3,551,987 A	1/1971	Wilkinson
2,527,256 A	10/1950	Jackson	3,568,675 A	3/1971	Harvey
2,578,686 A	12/1951	Fish	3,572,159 A	3/1971	Tschanz
2,638,901 A	5/1953	Sugarbaker	3,583,393 A	6/1971	Takahashi
2,674,149 A	4/1954	Benson	3,589,589 A	6/1971	Akopov
2,701,489 A	2/1955	Osborn	3,598,943 A	8/1971	Barrett
2,711,461 A	6/1955	Happe	3,604,561 A	9/1971	Mallina et al.
2,724,289 A	11/1955	Wight	3,608,549 A	9/1971	Merrill
2,742,955 A	4/1956	Dominguez	3,618,842 A	11/1971	Bryan
			3,635,394 A	1/1972	Natelson
			3,638,652 A	2/1972	Kelley
			3,640,317 A	2/1972	Panfili
			3,643,851 A	2/1972	Green et al.
			3,650,453 A	3/1972	Smith, Jr.
			3,661,339 A	5/1972	Shimizu
			3,661,666 A	5/1972	Foster et al.
			3,662,939 A	5/1972	Bryan
			3,685,250 A	8/1972	Henry et al.
			3,688,966 A	9/1972	Perkins et al.
			3,695,646 A	10/1972	Mommsen
			3,709,221 A	1/1973	Riely
			3,717,294 A	2/1973	Green
			3,724,237 A	4/1973	Wood
			3,726,755 A	4/1973	Shannon
			3,727,904 A	4/1973	Gabbey
			3,734,207 A	5/1973	Fishbein
			3,740,994 A	6/1973	De Carlo, Jr.
			3,744,495 A	7/1973	Johnson
			3,746,002 A	7/1973	Haller
			3,747,603 A	7/1973	Adler
			3,747,692 A	7/1973	Davidson
			3,751,902 A	8/1973	Kingsbury et al.
			3,752,161 A	8/1973	Bent
			3,799,151 A	3/1974	Fukaumi et al.
			3,808,452 A	4/1974	Hutchinson
			3,815,476 A	6/1974	Green et al.
			3,819,100 A	6/1974	Noiles et al.
			3,821,919 A	7/1974	Knohl
			3,826,978 A	7/1974	Kelly
			3,836,171 A	9/1974	Hayashi et al.
			3,837,555 A	9/1974	Green
			3,841,474 A	10/1974	Maier
			3,851,196 A	11/1974	Hinds

(56)

References Cited

U.S. PATENT DOCUMENTS

3,863,639 A	2/1975	Kleaveland	4,321,746 A	3/1982	Grinage
3,863,940 A	2/1975	Cummings	4,328,839 A	5/1982	Lyons et al.
3,883,624 A	5/1975	McKenzie et al.	4,331,277 A	5/1982	Green
3,885,491 A	5/1975	Curtis	4,340,331 A	7/1982	Savino
3,887,393 A	6/1975	La Rue, Jr.	4,347,450 A	8/1982	Colligan
3,892,228 A	7/1975	Mitsui	4,348,603 A	9/1982	Huber
3,894,174 A	7/1975	Cartun	4,349,028 A	9/1982	Green
3,902,247 A	9/1975	Fleer et al.	4,350,151 A	9/1982	Scott
3,940,844 A	3/1976	Colby et al.	4,353,371 A	10/1982	Cosman
3,944,163 A	3/1976	Hayashi et al.	4,357,940 A	11/1982	Muller
3,950,686 A	4/1976	Randall	4,361,057 A	11/1982	Kochera
3,952,747 A	4/1976	Kimmell, Jr.	4,366,544 A	12/1982	Shima et al.
3,955,581 A	5/1976	Spasiano et al.	4,369,013 A	1/1983	Abildgaard et al.
3,959,879 A	6/1976	Sellers	4,373,147 A	2/1983	Carlson, Jr.
RE28,932 E	8/1976	Noiles et al.	4,376,380 A	3/1983	Burgess
3,972,734 A	8/1976	King	4,379,457 A	4/1983	Gravener et al.
3,973,179 A	8/1976	Weber et al.	4,380,312 A	4/1983	Landrus
3,981,051 A	9/1976	Brumlik	4,382,326 A	5/1983	Rabuse
3,999,110 A	12/1976	Ramstrom et al.	4,383,634 A	5/1983	Green
4,025,216 A	5/1977	Hives	4,389,963 A	6/1983	Pearson
4,027,746 A	6/1977	Kine	4,393,728 A	7/1983	Larson et al.
4,034,143 A	7/1977	Sweet	4,394,613 A	7/1983	Cole
4,038,987 A	8/1977	Komiya	4,396,139 A	8/1983	Hall et al.
4,054,108 A	10/1977	Gill	4,397,311 A	8/1983	Kanshin et al.
4,060,089 A	11/1977	Noiles	4,402,445 A	9/1983	Green
4,066,133 A	1/1978	Voss	4,406,621 A	9/1983	Bailey
4,085,337 A	4/1978	Moeller	4,408,692 A	10/1983	Sigel et al.
4,100,820 A	7/1978	Evet	4,409,057 A	10/1983	Molenda et al.
4,106,446 A	8/1978	Yamada et al.	4,415,112 A	11/1983	Green
4,106,620 A	8/1978	Brimmer et al.	4,416,276 A	11/1983	Newton et al.
4,108,211 A	8/1978	Tanaka	4,417,890 A	11/1983	Dennehey et al.
4,111,206 A	9/1978	Vishnevsky et al.	4,421,264 A	12/1983	Arter et al.
4,127,227 A	11/1978	Green	4,423,456 A	12/1983	Zaidenweber
4,129,059 A	12/1978	Van Eck	4,425,915 A	1/1984	Ivanov
4,132,146 A	1/1979	Uhlig	4,428,376 A	1/1984	Mericle
4,135,517 A	1/1979	Reale	4,429,695 A	2/1984	Green
4,149,461 A	4/1979	Simeth	4,430,997 A	2/1984	DiGiovanni et al.
4,154,122 A	5/1979	Severin	4,434,796 A	3/1984	Karapetian et al.
4,160,857 A	7/1979	Nardella et al.	4,438,659 A	3/1984	Desplats
4,169,990 A	10/1979	Lerdman	4,442,964 A	4/1984	Becht
4,180,285 A	12/1979	Reneau	4,448,194 A	5/1984	DiGiovanni et al.
4,185,701 A	1/1980	Boys	4,451,743 A	5/1984	Suzuki et al.
4,190,042 A	2/1980	Sinnreich	4,452,376 A	6/1984	Klieman et al.
4,198,734 A	4/1980	Brumlik	4,454,887 A	6/1984	Kruger
4,198,982 A	4/1980	Fortner et al.	4,459,519 A	7/1984	Erdman
4,203,444 A	5/1980	Bonnell et al.	4,461,305 A	7/1984	Cibley
4,207,898 A	6/1980	Becht	4,467,805 A	8/1984	Fukuda
4,213,562 A	7/1980	Garrett et al.	4,468,597 A	8/1984	Baumard et al.
4,226,242 A	10/1980	Jarvik	4,469,481 A	9/1984	Kobayashi
4,239,431 A	12/1980	Davini	4,470,414 A	9/1984	Imagawa et al.
4,241,861 A	12/1980	Fleischer	4,471,780 A	9/1984	Menges et al.
4,244,372 A	1/1981	Kapitanov et al.	4,471,781 A	9/1984	Di Giovanni et al.
4,250,436 A	2/1981	Weissman	4,473,077 A	9/1984	Noiles et al.
4,261,244 A	4/1981	Becht et al.	4,475,679 A	10/1984	Fleury, Jr.
4,272,002 A	6/1981	Moshofsky	4,476,864 A	10/1984	Tezel
4,272,662 A	6/1981	Simpson	4,478,220 A	10/1984	Di Giovanni et al.
4,274,304 A	6/1981	Curtiss	4,480,641 A	11/1984	Failla et al.
4,274,398 A	6/1981	Scott, Jr.	4,481,458 A	11/1984	Lane
4,275,813 A	6/1981	Noiles	4,483,562 A	11/1984	Schoolman
4,278,091 A	7/1981	Borzzone	4,485,816 A	12/1984	Krumme
4,282,573 A	8/1981	Imai et al.	4,485,817 A	12/1984	Swiggett
4,289,131 A	9/1981	Mueller	4,486,928 A	12/1984	Tucker et al.
4,289,133 A	9/1981	Rothfuss	4,488,523 A	12/1984	Shichman
4,290,542 A	9/1981	Fedotov et al.	4,489,875 A	12/1984	Crawford et al.
D261,356 S	10/1981	Robinson	4,493,983 A	1/1985	Taggert
4,293,604 A	10/1981	Campbell	4,494,057 A	1/1985	Hotta
4,296,654 A	10/1981	Mercer	4,499,895 A	2/1985	Takayama
4,296,881 A	10/1981	Lee	4,500,024 A	2/1985	DiGiovanni et al.
4,304,236 A	12/1981	Conta et al.	D278,081 S	3/1985	Green
4,305,539 A	12/1981	Korolkov et al.	4,503,842 A	3/1985	Takayama
4,312,363 A	1/1982	Rothfuss et al.	4,505,272 A	3/1985	Utyamyshev et al.
4,312,685 A	1/1982	Riedl	4,505,273 A	3/1985	Braun et al.
4,317,451 A	3/1982	Cerwin et al.	4,505,414 A	3/1985	Filipi
4,319,576 A	3/1982	Rothfuss	4,506,671 A	3/1985	Green
4,321,002 A	3/1982	Froehlich	4,512,038 A	4/1985	Alexander et al.
			4,514,477 A	4/1985	Kobayashi
			4,520,817 A	6/1985	Green
			4,522,327 A	6/1985	Korthoff et al.
			4,526,174 A	7/1985	Froehlich

(56)

References Cited

U.S. PATENT DOCUMENTS

4,527,724 A	7/1985	Chow et al.	4,671,278 A	6/1987	Chin
4,530,357 A	7/1985	Pawloski et al.	4,671,280 A	6/1987	Dorband et al.
4,530,453 A	7/1985	Green	4,671,445 A	6/1987	Barker et al.
4,531,522 A	7/1985	Bedi et al.	4,672,964 A	6/1987	Dee et al.
4,532,927 A	8/1985	Miksza, Jr.	4,675,944 A	6/1987	Wells
4,540,202 A	9/1985	Amphoux et al.	4,676,245 A	6/1987	Fukuda
4,548,202 A	10/1985	Duncan	4,679,460 A	7/1987	Yoshigai
4,556,058 A	12/1985	Green	4,679,719 A	7/1987	Kramer
4,560,915 A	12/1985	Soultanian	4,684,051 A	8/1987	Akopov et al.
4,565,109 A	1/1986	Tsay	4,688,555 A	8/1987	Wardle
4,565,189 A	1/1986	Mabuchi	4,691,703 A	9/1987	Auth et al.
4,566,620 A	1/1986	Green et al.	4,693,248 A	9/1987	Failla
4,569,346 A	2/1986	Poirier	4,698,579 A	10/1987	Richter et al.
4,569,469 A	2/1986	Mongeon et al.	4,700,703 A	10/1987	Resnick et al.
4,571,213 A	2/1986	Ishimoto	4,705,038 A	11/1987	Sjostrom et al.
4,573,468 A	3/1986	Conta et al.	4,708,141 A	11/1987	Inoue et al.
4,573,469 A	3/1986	Golden et al.	4,709,120 A	11/1987	Pearson
4,573,622 A	3/1986	Green et al.	4,715,520 A	12/1987	Roehr, Jr. et al.
4,576,165 A	3/1986	Green et al.	4,719,917 A	1/1988	Barrows et al.
4,576,167 A	3/1986	Noiles	4,721,099 A	1/1988	Chikama
4,580,712 A	4/1986	Green	4,722,340 A	2/1988	Takayama et al.
4,585,153 A	4/1986	Failla et al.	4,724,840 A	2/1988	McVay et al.
4,586,501 A	5/1986	Claracq	4,727,308 A	2/1988	Huljak et al.
4,586,502 A	5/1986	Bedi et al.	4,728,020 A	3/1988	Green et al.
4,589,416 A	5/1986	Green	4,728,876 A	3/1988	Mongeon et al.
4,589,582 A	5/1986	Bilotti	4,729,260 A	3/1988	Dudden
4,589,870 A	5/1986	Citrin et al.	4,730,726 A	3/1988	Holzwarth
4,591,085 A	5/1986	Di Giovanni	4,741,336 A	5/1988	Failla et al.
RE32,214 E	7/1986	Schramm	4,743,214 A	5/1988	Tai-Cheng
4,597,753 A	7/1986	Turley	4,744,363 A	5/1988	Hasson
4,600,037 A	7/1986	Hatten	4,747,820 A	5/1988	Hornlein et al.
4,604,786 A	8/1986	Howie, Jr.	4,750,902 A	6/1988	Wuchinich et al.
4,605,001 A	8/1986	Rothfuss et al.	4,752,024 A	6/1988	Green et al.
4,605,004 A	8/1986	Di Giovanni et al.	4,754,909 A	7/1988	Barker et al.
4,606,343 A	8/1986	Conta et al.	4,755,070 A	7/1988	Cerutti
4,607,636 A	8/1986	Kula et al.	4,761,326 A	8/1988	Barnes et al.
4,607,638 A	8/1986	Crainich	4,763,669 A	8/1988	Jaeger
4,608,980 A	9/1986	Aihara	4,767,044 A	8/1988	Green
4,608,981 A	9/1986	Rothfuss et al.	D297,764 S	9/1988	Hunt et al.
4,610,250 A	9/1986	Green	4,773,420 A	9/1988	Green
4,610,383 A	9/1986	Rothfuss et al.	4,777,780 A	10/1988	Holzwarth
4,612,933 A	9/1986	Brinkerhoff et al.	4,781,186 A	11/1988	Simpson et al.
D286,180 S	10/1986	Korthoff	4,784,137 A	11/1988	Kulik et al.
D286,442 S	10/1986	Korthoff et al.	4,787,387 A	11/1988	Burbank, III et al.
4,617,893 A	10/1986	Donner et al.	4,788,485 A	11/1988	Kawagishi et al.
4,617,914 A	10/1986	Ueda	D298,967 S	12/1988	Hunt
4,619,262 A	10/1986	Taylor	4,790,225 A	12/1988	Moody et al.
4,619,391 A	10/1986	Sharkany et al.	4,790,314 A	12/1988	Weaver
4,624,401 A	11/1986	Gassner et al.	4,805,617 A	2/1989	Bedi et al.
D287,278 S	12/1986	Spreckelmeier	4,805,823 A	2/1989	Rothfuss
4,628,459 A	12/1986	Shinohara et al.	4,807,628 A	2/1989	Peters et al.
4,628,636 A	12/1986	Folger	4,809,695 A	3/1989	Gwathmey et al.
4,629,107 A	12/1986	Fedotov et al.	4,815,460 A	3/1989	Porat et al.
4,632,290 A	12/1986	Green et al.	4,817,643 A	4/1989	Olson
4,633,861 A	1/1987	Chow et al.	4,817,847 A	4/1989	Redtenbacher et al.
4,633,874 A	1/1987	Chow et al.	4,819,853 A	4/1989	Green
4,634,419 A	1/1987	Kreizman et al.	4,821,939 A	4/1989	Green
4,635,638 A	1/1987	Weintraub et al.	4,827,552 A	5/1989	Bojar et al.
4,641,076 A	2/1987	Linden	4,827,911 A	5/1989	Broadwin et al.
4,642,618 A	2/1987	Johnson et al.	4,828,542 A	5/1989	Hermann
4,642,738 A	2/1987	Meller	4,828,944 A	5/1989	Yabe et al.
4,643,173 A	2/1987	Bell et al.	4,830,855 A	5/1989	Stewart
4,643,731 A	2/1987	Eckenhoff	4,832,158 A	5/1989	Farrar et al.
4,646,722 A	3/1987	Silverstein et al.	4,833,937 A	5/1989	Nagano
4,646,745 A	3/1987	Noiles	4,834,096 A	5/1989	Oh et al.
4,651,734 A	3/1987	Doss et al.	4,834,720 A	5/1989	Blinkhorn
4,652,820 A	3/1987	Maresca	4,838,859 A	6/1989	Strassmann
4,654,028 A	3/1987	Suma	4,844,068 A	7/1989	Arata et al.
4,655,222 A	4/1987	Florez et al.	4,848,637 A	7/1989	Pruitt
4,662,555 A	5/1987	Thornton	4,856,078 A	8/1989	Konopka
4,663,874 A	5/1987	Sano et al.	4,860,644 A	8/1989	Kohl et al.
4,664,305 A	5/1987	Blake, III et al.	4,862,891 A	9/1989	Smith
4,665,916 A	5/1987	Green	4,863,423 A	9/1989	Wallace
4,667,674 A	5/1987	Korthoff et al.	4,865,030 A	9/1989	Polyak
4,669,647 A	6/1987	Storace	4,868,530 A	9/1989	Ahs
			4,868,958 A	9/1989	Suzuki et al.
			4,869,414 A	9/1989	Green et al.
			4,869,415 A	9/1989	Fox
			4,873,977 A	10/1989	Avant et al.

(56)

References Cited

U.S. PATENT DOCUMENTS

4,875,486 A	10/1989	Rapoport et al.	5,035,040 A	7/1991	Kerrigan et al.
4,880,015 A	11/1989	Nierman	5,037,018 A	8/1991	Matsuda et al.
4,890,613 A	1/1990	Golden et al.	5,038,109 A	8/1991	Goble et al.
4,892,244 A	1/1990	Fox et al.	5,038,247 A	8/1991	Kelley et al.
4,893,622 A	1/1990	Green et al.	5,040,715 A	8/1991	Green et al.
4,894,051 A	1/1990	Shiber	5,042,707 A	8/1991	Taheri
4,896,584 A	1/1990	Stoll et al.	5,056,953 A	10/1991	Marot et al.
4,896,678 A	1/1990	Ogawa	5,060,658 A	10/1991	Dejter, Jr. et al.
4,900,303 A	2/1990	Lemelson	5,061,269 A	10/1991	Muller
4,903,697 A	2/1990	Resnick et al.	5,062,491 A	11/1991	Takeshima et al.
4,909,789 A	3/1990	Taguchi et al.	5,062,563 A	11/1991	Green et al.
4,915,100 A	4/1990	Green	5,065,929 A	11/1991	Schulze et al.
4,919,679 A	4/1990	Averill et al.	5,071,052 A	12/1991	Rodak et al.
4,921,479 A	5/1990	Grayzel	5,071,430 A	12/1991	de Salis et al.
4,925,082 A	5/1990	Kim	5,074,454 A	12/1991	Peters
4,928,699 A	5/1990	Sasai	5,077,506 A	12/1991	Krause
4,930,503 A	6/1990	Pruitt	5,079,006 A	1/1992	Urquhart
4,930,674 A	6/1990	Barak	5,080,556 A	1/1992	Carreno
4,931,047 A	6/1990	Broadwin et al.	5,083,695 A	1/1992	Foslien et al.
4,931,737 A	6/1990	Hishiki	5,084,057 A	1/1992	Green et al.
4,932,960 A	6/1990	Green et al.	5,088,979 A	2/1992	Filipi et al.
4,933,800 A	6/1990	Yang	5,088,997 A	2/1992	Delahuerza et al.
4,933,843 A	6/1990	Scheller et al.	5,089,606 A	2/1992	Cole et al.
D309,350 S	7/1990	Sutherland et al.	5,094,247 A	3/1992	Hernandez et al.
4,938,408 A	7/1990	Bedi et al.	5,098,004 A	3/1992	Kerrigan
4,941,623 A	7/1990	Pruitt	5,098,360 A	3/1992	Hirota
4,943,182 A	7/1990	Hoblingre	5,100,042 A	3/1992	Gravener et al.
4,944,443 A	7/1990	Odds et al.	5,100,420 A	3/1992	Green et al.
4,946,067 A	8/1990	Kelsall	5,100,422 A	3/1992	Berguer et al.
4,948,327 A	8/1990	Crupi, Jr.	5,104,025 A	4/1992	Main et al.
4,949,707 A	8/1990	LeVahn et al.	5,104,397 A	4/1992	Vasconcelos et al.
4,950,268 A	8/1990	Rink	5,104,400 A	4/1992	Berguer et al.
4,951,860 A	8/1990	Peters et al.	5,106,008 A	4/1992	Tompkins et al.
4,951,861 A	8/1990	Schulze et al.	5,108,368 A	4/1992	Hammerslag et al.
4,954,960 A	9/1990	Lo et al.	5,109,722 A	5/1992	Hufnagle et al.
4,955,959 A	9/1990	Tompkins et al.	5,111,987 A	5/1992	Moeinzadeh et al.
4,957,212 A	9/1990	Duck et al.	5,116,349 A	5/1992	Aranyi
4,962,681 A	10/1990	Yang	D327,323 S	6/1992	Hunt
4,962,877 A	10/1990	Hervas	5,119,009 A	6/1992	McCaleb et al.
4,964,559 A	10/1990	Deniega et al.	5,122,156 A	6/1992	Granger et al.
4,964,863 A	10/1990	Kanshin et al.	5,124,990 A	6/1992	Williamson
4,965,709 A	10/1990	Ngo	5,129,570 A	7/1992	Schulze et al.
4,970,656 A	11/1990	Lo et al.	5,137,198 A	8/1992	Nobis et al.
4,973,274 A	11/1990	Hirukawa	5,139,513 A	8/1992	Segato
4,973,302 A	11/1990	Armour et al.	5,141,144 A	8/1992	Foslien et al.
4,976,173 A	12/1990	Yang	5,142,932 A	9/1992	Moya et al.
4,978,049 A	12/1990	Green	5,151,102 A	9/1992	Kamiyama et al.
4,978,333 A	12/1990	Broadwin et al.	5,155,941 A	10/1992	Takahashi et al.
4,979,952 A	12/1990	Kubota et al.	5,156,315 A	10/1992	Green et al.
4,984,564 A	1/1991	Yuen	5,156,609 A	10/1992	Nakao et al.
4,986,808 A	1/1991	Broadwin et al.	5,156,614 A	10/1992	Green et al.
4,987,049 A	1/1991	Komamura et al.	5,158,222 A	10/1992	Green et al.
4,988,334 A	1/1991	Hornlein et al.	5,158,567 A	10/1992	Green
4,995,877 A	2/1991	Ams et al.	D330,699 S	11/1992	Gill
4,995,959 A	2/1991	Metzner	5,163,598 A	11/1992	Peters et al.
4,996,975 A	3/1991	Nakamura	5,164,652 A	11/1992	Johnson et al.
5,001,649 A	3/1991	Lo et al.	5,168,605 A	12/1992	Bartlett
5,002,543 A	3/1991	Bradshaw et al.	5,170,925 A	12/1992	Madden et al.
5,002,553 A	3/1991	Shiber	5,171,247 A	12/1992	Hughett et al.
5,005,754 A	4/1991	Van Overloop	5,171,249 A	12/1992	Stefanchik et al.
5,009,222 A	4/1991	Her	5,171,253 A	12/1992	Klieman
5,009,661 A	4/1991	Michelson	5,173,053 A	12/1992	Swanson et al.
5,012,411 A	4/1991	Policastro et al.	5,173,133 A	12/1992	Morin et al.
5,014,898 A	5/1991	Heidrich	5,176,677 A	1/1993	Wuchinich
5,014,899 A	5/1991	Presty et al.	5,176,688 A	1/1993	Narayan et al.
5,015,227 A	5/1991	Broadwin et al.	5,181,514 A	1/1993	Solomon et al.
5,018,515 A	5/1991	Gilman	5,187,422 A	2/1993	Izenbaard et al.
5,018,657 A	5/1991	Pedlick et al.	5,188,102 A	2/1993	Idemoto et al.
5,024,652 A	6/1991	Dumenek et al.	5,188,111 A	2/1993	Yates et al.
5,024,671 A	6/1991	Tu et al.	5,190,517 A	3/1993	Zieve et al.
5,025,559 A	6/1991	McCullough	5,190,544 A	3/1993	Chapman et al.
5,027,834 A	7/1991	Pruitt	5,190,560 A	3/1993	Woods et al.
5,030,226 A	7/1991	Green et al.	5,190,657 A	3/1993	Heagle et al.
5,031,814 A	7/1991	Tompkins et al.	5,192,288 A	3/1993	Thompson et al.
5,033,552 A	7/1991	Hu	5,193,731 A	3/1993	Aranyi
			5,195,505 A	3/1993	Josefsen
			5,195,968 A	3/1993	Lundquist et al.
			5,197,648 A	3/1993	Gingold
			5,197,649 A	3/1993	Bessler et al.

(56)

References Cited

U.S. PATENT DOCUMENTS

5,197,966 A	3/1993	Sommerkamp	5,302,148 A	4/1994	Heinz
5,197,970 A	3/1993	Green et al.	5,303,606 A	4/1994	Kokinda
5,200,280 A	4/1993	Karasa	5,304,204 A	4/1994	Bregen
5,201,750 A	4/1993	Hocherl et al.	D347,474 S	5/1994	Olson
5,205,459 A	4/1993	Brinkerhoff et al.	5,307,976 A	5/1994	Olson et al.
5,207,672 A	5/1993	Roth et al.	5,308,353 A	5/1994	Beurrier
5,207,697 A	5/1993	Carusillo et al.	5,308,358 A	5/1994	Bond et al.
5,209,747 A	5/1993	Knoepfler	5,308,576 A	5/1994	Green et al.
5,209,756 A	5/1993	Seedhom et al.	5,309,387 A	5/1994	Mori et al.
5,211,649 A	5/1993	Kohler et al.	5,309,927 A	5/1994	Welch
5,211,655 A	5/1993	Hasson	5,312,023 A	5/1994	Green et al.
5,217,457 A	6/1993	Delahuerga et al.	5,312,024 A	5/1994	Grant et al.
5,217,478 A	6/1993	Rexroth	5,312,329 A	5/1994	Beaty et al.
5,219,111 A	6/1993	Bilotti et al.	5,313,935 A	5/1994	Kortenbach et al.
5,220,269 A	6/1993	Chen et al.	5,313,967 A	5/1994	Lieber et al.
5,221,036 A	6/1993	Takase	5,314,424 A	5/1994	Nicholas
5,221,281 A	6/1993	Klicek	5,314,445 A	5/1994	Heidmueller nee Degwitz et al.
5,222,945 A	6/1993	Basnight	5,314,466 A	5/1994	Stern et al.
5,222,963 A	6/1993	Brinkerhoff et al.	5,318,221 A	6/1994	Green et al.
5,222,975 A	6/1993	Crainich	5,320,627 A	6/1994	Sorensen et al.
5,222,976 A	6/1993	Yoon	D348,930 S	7/1994	Olson
5,223,675 A	6/1993	Taft	5,326,013 A	7/1994	Green et al.
D338,729 S	8/1993	Sprecklemeier et al.	5,329,923 A	7/1994	Lundquist
5,234,447 A	8/1993	Kaster et al.	5,330,486 A	7/1994	Wilk
5,236,269 A	8/1993	Handy	5,330,487 A	7/1994	Thornton et al.
5,236,424 A	8/1993	Imran	5,330,502 A	7/1994	Hassler et al.
5,236,440 A	8/1993	Hlavacek	5,331,971 A	7/1994	Bales et al.
5,239,981 A	8/1993	Anapliotis	5,332,142 A	7/1994	Robinson et al.
5,240,163 A	8/1993	Stein et al.	5,333,422 A	8/1994	Warren et al.
5,242,456 A	9/1993	Nash et al.	5,333,772 A	8/1994	Rothfuss et al.
5,242,457 A	9/1993	Akopov et al.	5,333,773 A	8/1994	Main et al.
5,244,462 A	9/1993	Delahuerga et al.	5,334,183 A	8/1994	Wuchinich
5,246,156 A	9/1993	Rothfuss et al.	5,336,130 A	8/1994	Ray
5,246,443 A	9/1993	Mai	5,336,229 A	8/1994	Noda
5,253,793 A	10/1993	Green et al.	5,336,232 A	8/1994	Green et al.
5,258,007 A	11/1993	Spetzler et al.	5,338,317 A	8/1994	Hasson et al.
5,258,008 A	11/1993	Wilk	5,339,799 A	8/1994	Kami et al.
5,258,009 A	11/1993	Connors	5,341,724 A	8/1994	Vatel
5,258,010 A	11/1993	Green et al.	5,341,807 A	8/1994	Nardella
5,258,012 A	11/1993	Luscombe et al.	5,341,810 A	8/1994	Dardel
5,259,366 A	11/1993	Reydel et al.	5,342,380 A	8/1994	Hood
5,259,835 A	11/1993	Clark et al.	5,342,381 A	8/1994	Tidemand
5,260,637 A	11/1993	Pizzi	5,342,385 A	8/1994	Norelli et al.
5,261,135 A	11/1993	Mitchell	5,342,395 A	8/1994	Jarrett et al.
5,261,877 A	11/1993	Fine et al.	5,342,396 A	8/1994	Cook
5,261,922 A	11/1993	Hood	5,343,382 A	8/1994	Hale et al.
5,263,629 A	11/1993	Trumbull et al.	5,343,391 A	8/1994	Mushabac
5,263,937 A	11/1993	Shipp	5,344,059 A	9/1994	Green et al.
5,263,973 A	11/1993	Cook	5,344,060 A	9/1994	Gravener et al.
5,264,218 A	11/1993	Rogozinski	5,344,454 A	9/1994	Clarke et al.
5,268,622 A	12/1993	Philipp	5,346,504 A	9/1994	Ortiz et al.
5,269,794 A	12/1993	Rexroth	5,348,259 A	9/1994	Blanco et al.
5,271,543 A	12/1993	Grant et al.	5,350,104 A	9/1994	Main et al.
5,271,544 A	12/1993	Fox et al.	5,350,355 A	9/1994	Sklar
RE34,519 E	1/1994	Fox et al.	5,350,388 A	9/1994	Epstein
5,275,322 A	1/1994	Brinkerhoff et al.	5,350,391 A	9/1994	Iacovelli
5,275,323 A	1/1994	Schulze et al.	5,350,400 A	9/1994	Esposito et al.
5,275,608 A	1/1994	Forman et al.	5,352,229 A	10/1994	Goble et al.
5,279,416 A	1/1994	Malec et al.	5,352,235 A	10/1994	Koros et al.
5,281,216 A	1/1994	Klicek	5,352,238 A	10/1994	Green et al.
5,281,400 A	1/1994	Berry, Jr.	5,353,798 A	10/1994	Sieben
5,282,806 A	2/1994	Haber et al.	5,354,250 A	10/1994	Christensen
5,282,826 A	2/1994	Quadri	5,354,303 A	10/1994	Spaeth et al.
5,282,829 A	2/1994	Hermes	5,356,006 A	10/1994	Alpern et al.
5,284,128 A	2/1994	Hart	5,356,064 A	10/1994	Green et al.
5,285,381 A	2/1994	Iskarous et al.	5,358,506 A	10/1994	Green et al.
5,285,945 A	2/1994	Brinkerhoff et al.	5,358,510 A	10/1994	Luscombe et al.
5,286,253 A	2/1994	Fucci	5,359,231 A	10/1994	Flowers et al.
5,289,963 A	3/1994	McGarry et al.	D352,780 S	11/1994	Glaeser et al.
5,290,271 A	3/1994	Jernberg	5,359,993 A	11/1994	Slater et al.
5,290,310 A	3/1994	Makower et al.	5,360,305 A	11/1994	Kerrigan
5,291,133 A	3/1994	Gokhale et al.	5,360,428 A	11/1994	Hutchinson, Jr.
5,292,053 A	3/1994	Bilotti et al.	5,361,902 A	11/1994	Abidin et al.
5,293,024 A	3/1994	Sugahara et al.	5,364,001 A	11/1994	Bryan
5,297,714 A	3/1994	Kramer	5,364,002 A	11/1994	Green et al.
			5,364,003 A	11/1994	Williamson, IV
			5,366,133 A	11/1994	Geiste
			5,366,134 A	11/1994	Green et al.
			5,366,479 A	11/1994	McGarry et al.

(56)

References Cited

U.S. PATENT DOCUMENTS

5,368,015 A	11/1994	Wilk	5,431,666 A	7/1995	Sauer et al.
5,368,592 A	11/1994	Stern et al.	5,431,668 A	7/1995	Burbank, III et al.
5,369,565 A	11/1994	Chen et al.	5,433,721 A	7/1995	Hooven et al.
5,370,645 A	12/1994	Klicek et al.	5,437,681 A	8/1995	Meade et al.
5,372,124 A	12/1994	Takayama et al.	5,438,302 A	8/1995	Goble
5,372,596 A	12/1994	Klicek et al.	5,438,997 A	8/1995	Sieben et al.
5,372,602 A	12/1994	Burke	5,439,155 A	8/1995	Viola
5,374,277 A	12/1994	Hassler	5,439,156 A	8/1995	Grant et al.
5,375,588 A	12/1994	Yoon	5,439,479 A	8/1995	Shichman et al.
5,376,095 A	12/1994	Ortiz	5,441,191 A	8/1995	Linden
5,379,933 A	1/1995	Green et al.	5,441,193 A	8/1995	Gravener
5,381,649 A	1/1995	Webb	5,441,483 A	8/1995	Avitall
5,381,782 A	1/1995	DeLaRama et al.	5,441,494 A	8/1995	Ortiz
5,381,943 A	1/1995	Allen et al.	5,441,499 A	8/1995	Fritzsch
5,382,247 A	1/1995	Cimino et al.	5,443,197 A	8/1995	Malis et al.
5,383,460 A	1/1995	Jang et al.	5,443,198 A	8/1995	Viola et al.
5,383,874 A	1/1995	Jackson et al.	5,443,463 A	8/1995	Stern et al.
5,383,880 A	1/1995	Hooven	5,444,113 A	8/1995	Sinclair et al.
5,383,881 A	1/1995	Green et al.	5,445,155 A	8/1995	Sieben
5,383,882 A	1/1995	Buess et al.	5,445,304 A	8/1995	Plyley et al.
5,383,888 A	1/1995	Zvenyatsky et al.	5,445,604 A	8/1995	Lang
5,383,895 A	1/1995	Holmes et al.	5,445,644 A	8/1995	Pietrafitta et al.
5,388,568 A	2/1995	van der Heide	5,446,646 A	8/1995	Miyazaki
5,389,072 A	2/1995	Imran	5,447,265 A	9/1995	Vidal et al.
5,389,098 A	2/1995	Tsuruta et al.	5,447,417 A	9/1995	Kuhl et al.
5,389,102 A	2/1995	Green et al.	5,447,513 A	9/1995	Davison et al.
5,389,104 A	2/1995	Hahnen et al.	5,449,355 A	9/1995	Rhum et al.
5,391,180 A	2/1995	Tovey et al.	5,449,365 A	9/1995	Green et al.
5,392,979 A	2/1995	Green et al.	5,449,370 A	9/1995	Vaitekunas
5,395,030 A	3/1995	Kuramoto et al.	5,452,836 A	9/1995	Huitema et al.
5,395,033 A	3/1995	Byrne et al.	5,452,837 A	9/1995	Williamson, IV et al.
5,395,034 A	3/1995	Allen et al.	5,454,378 A	10/1995	Palmer et al.
5,395,312 A	3/1995	Desai	5,454,822 A	10/1995	Schob et al.
5,395,384 A	3/1995	Duthoit et al.	5,454,827 A	10/1995	Aust et al.
5,397,046 A	3/1995	Savage et al.	5,456,401 A	10/1995	Green et al.
5,397,324 A	3/1995	Carroll et al.	5,456,917 A	10/1995	Wise et al.
5,400,267 A	3/1995	Denen et al.	5,458,279 A	10/1995	Plyley
5,403,276 A	4/1995	Schechter et al.	5,458,579 A	10/1995	Chodorow et al.
5,403,312 A	4/1995	Yates et al.	5,462,215 A	10/1995	Viola et al.
5,404,106 A	4/1995	Matsuda	5,464,013 A	11/1995	Lemelson
5,404,870 A	4/1995	Brinkerhoff et al.	5,464,144 A	11/1995	Guy et al.
5,404,960 A	4/1995	Wada et al.	5,464,300 A	11/1995	Crainich
5,405,072 A	4/1995	Zlock et al.	5,465,819 A	11/1995	Weilant et al.
5,405,073 A	4/1995	Porter	5,465,894 A	11/1995	Clark et al.
5,405,344 A	4/1995	Williamson et al.	5,465,895 A	11/1995	Knodel et al.
5,405,360 A	4/1995	Tovey	5,465,896 A	11/1995	Allen et al.
5,407,293 A	4/1995	Crainich	5,466,020 A	11/1995	Page et al.
5,408,409 A	4/1995	Glassman et al.	5,467,911 A	11/1995	Tsuruta et al.
5,409,498 A	4/1995	Braddock et al.	5,468,253 A	11/1995	Bezwada et al.
5,409,703 A	4/1995	McAnalley et al.	5,470,006 A	11/1995	Rodak
D357,981 S	5/1995	Green et al.	5,470,007 A	11/1995	Plyley et al.
5,411,481 A	5/1995	Allen et al.	5,470,008 A	11/1995	Rodak
5,411,508 A	5/1995	Bessler et al.	5,470,009 A	11/1995	Rodak
5,413,107 A	5/1995	Oakley et al.	5,470,010 A	11/1995	Rothfuss et al.
5,413,267 A	5/1995	Solyntjes et al.	5,471,129 A	11/1995	Mann
5,413,268 A	5/1995	Green et al.	5,472,132 A	12/1995	Savage et al.
5,413,272 A	5/1995	Green et al.	5,472,442 A	12/1995	Klicek
5,413,573 A	5/1995	Koivukangas	5,473,204 A	12/1995	Temple
5,415,334 A	5/1995	Williamson et al.	5,474,057 A	12/1995	Makower et al.
5,415,335 A	5/1995	Knodel, Jr.	5,474,223 A	12/1995	Viola et al.
5,417,203 A	5/1995	Tovey et al.	5,474,566 A	12/1995	Alesi et al.
5,417,361 A	5/1995	Williamson, IV	5,474,570 A	12/1995	Kockerling et al.
5,419,766 A	5/1995	Chang et al.	5,474,738 A	12/1995	Nichols et al.
5,421,829 A	6/1995	Olichney et al.	5,476,206 A	12/1995	Green et al.
5,422,567 A	6/1995	Matsunaga	5,476,479 A	12/1995	Green et al.
5,423,471 A	6/1995	Mastri et al.	5,476,481 A	12/1995	Schondorf
5,423,809 A	6/1995	Klicek	5,478,003 A	12/1995	Green et al.
5,423,835 A	6/1995	Green et al.	5,478,354 A	12/1995	Tovey et al.
5,425,355 A	6/1995	Kulick	5,480,089 A	1/1996	Blewett
5,425,745 A	6/1995	Green et al.	5,480,409 A	1/1996	Riza
5,427,298 A	6/1995	Tegtmeier	5,482,197 A	1/1996	Green et al.
5,431,322 A	7/1995	Green et al.	5,483,952 A	1/1996	Aranyi
5,431,323 A	7/1995	Smith et al.	5,484,095 A	1/1996	Green et al.
5,431,645 A	7/1995	Smith et al.	5,484,398 A	1/1996	Stoddard
5,431,654 A	7/1995	Nic	5,484,451 A	1/1996	Akopov et al.
			5,485,947 A	1/1996	Olson et al.
			5,485,952 A	1/1996	Fontayne
			5,487,377 A	1/1996	Smith et al.
			5,487,499 A	1/1996	Sorrentino et al.

(56)

References Cited

U.S. PATENT DOCUMENTS

5,487,500 A	1/1996	Knodel et al.	5,560,532 A	10/1996	DeFonzo et al.
5,489,058 A	2/1996	Plyley et al.	5,561,881 A	10/1996	Klinger et al.
5,489,256 A	2/1996	Adair	5,562,239 A	10/1996	Boiarski et al.
5,489,290 A	2/1996	Furnish	5,562,241 A	10/1996	Knodel et al.
5,490,819 A	2/1996	Nicholas et al.	5,562,682 A	10/1996	Oberlin et al.
5,492,671 A	2/1996	Krafft	5,562,690 A	10/1996	Green et al.
5,496,312 A	3/1996	Klicek	5,562,701 A	10/1996	Huitema et al.
5,496,317 A	3/1996	Goble et al.	5,562,702 A	10/1996	Huitema et al.
5,497,933 A	3/1996	DeFonzo et al.	5,563,481 A	10/1996	Krause
5,498,164 A	3/1996	Ward et al.	5,564,615 A	10/1996	Bishop et al.
5,498,838 A	3/1996	Furman	5,569,161 A	10/1996	Ebling et al.
5,501,654 A	3/1996	Failla et al.	5,569,270 A	10/1996	Weng
5,503,320 A	4/1996	Webster et al.	5,569,284 A	10/1996	Young et al.
5,503,635 A	4/1996	Sauer et al.	5,571,090 A	11/1996	Sherts
5,503,638 A	4/1996	Cooper et al.	5,571,100 A	11/1996	Goble et al.
5,505,363 A	4/1996	Green et al.	5,571,116 A	11/1996	Bolanos et al.
5,507,425 A	4/1996	Ziglioli	5,571,285 A	11/1996	Chow et al.
5,507,426 A	4/1996	Young et al.	5,571,488 A	11/1996	Beerstecher et al.
5,507,773 A	4/1996	Huitema et al.	5,573,169 A	11/1996	Green et al.
5,509,596 A	4/1996	Green et al.	5,573,543 A	11/1996	Akopov et al.
5,509,916 A	4/1996	Taylor	5,574,431 A	11/1996	McKeown et al.
5,509,918 A	4/1996	Romano	5,575,054 A	11/1996	Klinzing et al.
5,511,564 A	4/1996	Wilk	5,575,789 A	11/1996	Bell et al.
5,514,129 A	5/1996	Smith	5,575,799 A	11/1996	Bolanos et al.
5,514,149 A	5/1996	Green et al.	5,575,803 A	11/1996	Cooper et al.
5,514,157 A	5/1996	Nicholas et al.	5,575,805 A	11/1996	Li
5,518,163 A	5/1996	Hooven	5,577,654 A	11/1996	Bishop
5,518,164 A	5/1996	Hooven	5,578,052 A	11/1996	Koros et al.
5,520,609 A	5/1996	Moll et al.	5,579,978 A	12/1996	Green et al.
5,520,634 A	5/1996	Fox et al.	5,580,067 A	12/1996	Hamblin et al.
5,520,678 A	5/1996	Heckele et al.	5,582,611 A	12/1996	Tsuruta et al.
5,520,700 A	5/1996	Beyar et al.	5,582,617 A	12/1996	Klieman et al.
5,522,817 A	6/1996	Sander et al.	5,582,907 A	12/1996	Pall
5,522,831 A	6/1996	Sleister et al.	5,583,114 A	12/1996	Barrows et al.
5,527,264 A	6/1996	Moll et al.	5,584,425 A	12/1996	Savage et al.
5,527,320 A	6/1996	Carruthers et al.	5,586,711 A	12/1996	Plyley et al.
5,529,235 A	6/1996	Boiarski et al.	5,588,579 A	12/1996	Schnut et al.
D372,086 S	7/1996	Grasso et al.	5,588,580 A	12/1996	Paul et al.
5,531,305 A	7/1996	Roberts et al.	5,588,581 A	12/1996	Conlon et al.
5,531,744 A	7/1996	Nardella et al.	5,591,170 A	1/1997	Spievack et al.
5,531,856 A	7/1996	Moll et al.	5,591,187 A	1/1997	Dekel
5,533,521 A	7/1996	Granger	5,597,107 A	1/1997	Knodel et al.
5,533,581 A	7/1996	Barth et al.	5,599,151 A	2/1997	Daum et al.
5,533,661 A	7/1996	Main et al.	5,599,279 A	2/1997	Slotman et al.
5,535,934 A	7/1996	Boiarski et al.	5,599,344 A	2/1997	Paterson
5,535,935 A	7/1996	Vidal et al.	5,599,350 A	2/1997	Schulze et al.
5,535,937 A	7/1996	Boiarski et al.	5,599,852 A	2/1997	Scopelianos et al.
5,540,375 A	7/1996	Bolanos et al.	5,601,224 A	2/1997	Bishop et al.
5,540,705 A	7/1996	Meade et al.	5,601,573 A	2/1997	Fogelberg et al.
5,541,376 A	7/1996	Ladtchow et al.	5,601,604 A	2/1997	Vincent
5,541,489 A	7/1996	Dunstan	5,602,449 A	2/1997	Krause et al.
5,542,594 A	8/1996	McKean et al.	5,603,443 A	2/1997	Clark et al.
5,542,945 A	8/1996	Fritzsich	5,605,272 A	2/1997	Witt et al.
5,542,949 A	8/1996	Yoon	5,605,273 A	2/1997	Hamblin et al.
5,543,119 A	8/1996	Sutter et al.	5,607,094 A	3/1997	Clark et al.
5,543,695 A	8/1996	Culp et al.	5,607,095 A	3/1997	Smith et al.
5,544,802 A	8/1996	Crainich	5,607,433 A	3/1997	Polla et al.
5,547,117 A	8/1996	Hamblin et al.	5,607,436 A	3/1997	Pratt et al.
5,549,583 A	8/1996	Sanford et al.	5,607,450 A	3/1997	Zvenyatsky et al.
5,549,621 A	8/1996	Bessler et al.	5,607,474 A	3/1997	Athanasidou et al.
5,549,627 A	8/1996	Kieturakis	5,609,285 A	3/1997	Grant et al.
5,549,628 A	8/1996	Cooper et al.	5,609,601 A	3/1997	Kolesa et al.
5,549,637 A	8/1996	Crainich	5,611,709 A	3/1997	McAnulty
5,551,622 A	9/1996	Yoon	5,613,499 A	3/1997	Palmer et al.
5,553,624 A	9/1996	Francesca et al.	5,613,937 A	3/1997	Garrison et al.
5,553,675 A	9/1996	Pitzen et al.	5,613,966 A	3/1997	Makower et al.
5,553,765 A	9/1996	Knodel et al.	5,614,887 A	3/1997	Buchbinder
5,554,148 A	9/1996	Aebischer et al.	5,615,820 A	4/1997	Viola
5,554,169 A	9/1996	Green et al.	5,618,294 A	4/1997	Aust et al.
5,556,020 A	9/1996	Hou	5,618,303 A	4/1997	Marlow et al.
5,556,416 A	9/1996	Clark et al.	5,618,307 A	4/1997	Donlon et al.
5,558,533 A	9/1996	Hashizawa et al.	5,619,992 A	4/1997	Guthrie et al.
5,558,665 A	9/1996	Kieturakis	5,620,289 A	4/1997	Curry
5,558,671 A	9/1996	Yates	5,620,326 A	4/1997	Younker
5,560,530 A	10/1996	Bolanos et al.	5,620,452 A	4/1997	Yoon
			5,624,398 A	4/1997	Smith et al.
			5,624,452 A	4/1997	Yates
			5,626,587 A	5/1997	Bishop et al.
			5,626,595 A	5/1997	Sklar et al.

(56)

References Cited

U.S. PATENT DOCUMENTS

5,626,979 A	5/1997	Mitsui et al.	5,690,269 A	11/1997	Bolanos et al.
5,628,446 A	5/1997	Geiste et al.	5,690,675 A	11/1997	Sawyer et al.
5,628,743 A	5/1997	Cimino	5,692,668 A	12/1997	Schulze et al.
5,628,745 A	5/1997	Bek	5,693,020 A	12/1997	Rauh
5,630,539 A	5/1997	Plyley et al.	5,693,042 A	12/1997	Boiarski et al.
5,630,540 A	5/1997	Blewett	5,693,051 A	12/1997	Schulze et al.
5,630,541 A	5/1997	Williamson, IV et al.	5,695,494 A	12/1997	Becker
5,630,782 A	5/1997	Adair	5,695,502 A	12/1997	Pier et al.
5,631,973 A	5/1997	Green	5,695,504 A	12/1997	Gifford, III et al.
5,632,432 A	5/1997	Schulze et al.	5,695,524 A	12/1997	Kelley et al.
5,632,433 A	5/1997	Grant et al.	5,697,542 A	12/1997	Knodel et al.
5,633,374 A	5/1997	Humphrey et al.	5,697,543 A	12/1997	Burdorff
5,634,584 A	6/1997	Okorochoa et al.	5,697,909 A	12/1997	Eggers et al.
5,636,779 A	6/1997	Palmer	5,697,943 A	12/1997	Sauer et al.
5,636,780 A	6/1997	Green et al.	5,700,270 A	12/1997	Peysner et al.
5,637,110 A	6/1997	Pennybacker et al.	5,700,276 A	12/1997	Benecke
5,638,582 A	6/1997	Klatt et al.	5,702,387 A	12/1997	Arts et al.
5,639,008 A	6/1997	Gallagher et al.	5,702,408 A	12/1997	Wales et al.
D381,077 S	7/1997	Hunt	5,702,409 A	12/1997	Rayburn et al.
5,643,291 A	7/1997	Pier et al.	5,704,087 A	1/1998	Strub
5,643,293 A	7/1997	Kogasaka et al.	5,704,534 A	1/1998	Huitema et al.
5,643,294 A	7/1997	Tovey et al.	5,706,997 A	1/1998	Green et al.
5,643,319 A	7/1997	Green et al.	5,706,998 A	1/1998	Plyley et al.
5,645,209 A	7/1997	Green et al.	5,707,392 A	1/1998	Kortenbach
5,647,526 A	7/1997	Green et al.	5,709,334 A	1/1998	Sorrentino et al.
5,647,869 A	7/1997	Goble et al.	5,709,335 A	1/1998	Heck
5,649,937 A	7/1997	Bito et al.	5,709,680 A	1/1998	Yates et al.
5,649,956 A	7/1997	Jensen et al.	5,709,706 A	1/1998	Kienzle et al.
5,651,491 A	7/1997	Heaton et al.	5,711,472 A	1/1998	Bryan
5,651,762 A	7/1997	Bridges	5,711,960 A	1/1998	Shikinami
5,651,821 A	7/1997	Uchida	5,712,460 A	1/1998	Carr et al.
5,653,373 A	8/1997	Green et al.	5,712,460 A	1/1998	Schrenk et al.
5,653,374 A	8/1997	Young et al.	5,713,128 A	2/1998	Huitema
5,653,677 A	8/1997	Okada et al.	5,713,505 A	2/1998	Lontine et al.
5,653,721 A	8/1997	Knodel et al.	5,713,895 A	2/1998	Nardella
5,653,748 A	8/1997	Strecker	5,713,896 A	2/1998	Bezwada et al.
5,655,698 A	8/1997	Yoon	5,713,920 A	2/1998	Lanzoni
5,656,917 A	8/1997	Theobald	5,715,604 A	2/1998	Kliegis et al.
5,657,417 A	8/1997	Di Troia	5,715,836 A	2/1998	Kelley et al.
5,657,429 A	8/1997	Wang et al.	5,715,987 A	2/1998	Palmer
5,657,921 A	8/1997	Young et al.	5,715,988 A	2/1998	Viola et al.
5,658,238 A	8/1997	Suzuki et al.	5,716,352 A	2/1998	Yates
5,658,281 A	8/1997	Heard	5,716,366 A	2/1998	Palmer et al.
5,658,298 A	8/1997	Vincent et al.	5,718,359 A	2/1998	Green et al.
5,658,300 A	8/1997	Bito et al.	5,718,360 A	2/1998	Cotellessa
5,658,307 A	8/1997	Exconde	5,718,548 A	2/1998	Livneh
5,662,258 A	9/1997	Knodel et al.	5,718,714 A	2/1998	Eggleston et al.
5,662,260 A	9/1997	Yoon	5,720,744 A	2/1998	Geary et al.
5,662,662 A	9/1997	Bishop et al.	D393,067 S	3/1998	Tavori
5,662,667 A	9/1997	Knodel	5,724,025 A	3/1998	Oberlin et al.
5,664,404 A	9/1997	Ivanov et al.	5,725,536 A	3/1998	Simon et al.
5,665,085 A	9/1997	Nardella	5,725,554 A	3/1998	Vidal et al.
5,667,517 A	9/1997	Hooven	5,728,110 A	3/1998	Sherts
5,667,526 A	9/1997	Levin	5,728,113 A	3/1998	Bimbo et al.
5,667,527 A	9/1997	Cook	5,728,121 A	3/1998	Allgeyer
5,667,864 A	9/1997	Landoll	5,730,758 A	3/1998	Adair
5,669,544 A	9/1997	Schulze et al.	5,732,712 A	3/1998	Stone et al.
5,669,904 A	9/1997	Platt, Jr. et al.	5,732,821 A	3/1998	Clark et al.
5,669,907 A	9/1997	Platt, Jr. et al.	5,732,871 A	3/1998	Bolduc et al.
5,669,918 A	9/1997	Balazs et al.	5,732,872 A	3/1998	Daugherty et al.
5,672,945 A	9/1997	Krause	5,733,308 A	3/1998	Vidal et al.
5,673,840 A	10/1997	Schulze et al.	5,735,445 A	4/1998	Yates et al.
5,673,841 A	10/1997	Schulze et al.	5,735,848 A	4/1998	Measamer et al.
5,673,842 A	10/1997	Bittner et al.	5,735,874 A	4/1998	Cisar et al.
5,674,184 A	10/1997	Hassler, Jr.	5,736,271 A	4/1998	Blewett
5,674,286 A	10/1997	D'Alessio et al.	5,738,474 A	4/1998	Moll et al.
5,678,748 A	10/1997	Plyley et al.	5,738,629 A	4/1998	Lands et al.
5,680,981 A	10/1997	Mililli et al.	5,738,648 A	4/1998	Nakao et al.
5,680,982 A	10/1997	Schulze et al.	5,741,271 A	4/1998	Jones et al.
5,680,983 A	10/1997	Plyley et al.	5,743,456 A	4/1998	Philipp
5,681,341 A	10/1997	Lunsford et al.	5,747,953 A	5/1998	Bacich et al.
5,683,349 A	11/1997	Makower et al.	5,749,889 A	5/1998	Vidal et al.
5,685,474 A	11/1997	Seeber	5,749,893 A	5/1998	Cook
5,686,090 A	11/1997	Schilder et al.	5,749,896 A	5/1998	Melanson et al.
5,688,270 A	11/1997	Yates et al.	5,749,968 A	5/1998	Bolanos et al.
			5,752,644 A	5/1998	Francis et al.
			5,752,965 A	5/1998	Yoon
			5,752,970 A	5/1998	Kieturakis
			5,752,973 A	5/1998	Yates et al.
			5,755,717 A	5/1998	

(56)

References Cited

U.S. PATENT DOCUMENTS

5,755,726 A	5/1998	Pratt et al.	5,823,066 A	10/1998	Huitema et al.
5,758,814 A	6/1998	Gallagher et al.	5,824,333 A	10/1998	Scopelianos et al.
5,762,255 A	6/1998	Chrisman et al.	5,826,776 A	10/1998	Schulze et al.
5,762,256 A	6/1998	Mastri et al.	5,827,271 A	10/1998	Buysse et al.
5,762,458 A	6/1998	Wang et al.	5,827,298 A	10/1998	Hart et al.
5,765,565 A	6/1998	Adair	5,827,323 A	10/1998	Klieman et al.
5,766,186 A	6/1998	Faraz et al.	5,829,662 A	11/1998	Allen et al.
5,766,188 A	6/1998	Igaki	5,830,598 A	11/1998	Patterson
5,766,205 A	6/1998	Zvenyatsky et al.	5,833,690 A	11/1998	Yates et al.
5,769,303 A	6/1998	Knodel et al.	5,833,695 A	11/1998	Yoon
5,769,640 A	6/1998	Jacobus et al.	5,833,696 A	11/1998	Whitfield et al.
5,769,748 A	6/1998	Eyerly et al.	5,836,503 A	11/1998	Ehrenfels et al.
5,769,791 A	6/1998	Benaron et al.	5,836,960 A	11/1998	Kolesa et al.
5,769,892 A	6/1998	Kingwell	5,839,369 A	11/1998	Chatterjee et al.
5,772,099 A	6/1998	Gravener	5,839,639 A	11/1998	Sauer et al.
5,772,379 A	6/1998	Evensen	5,841,284 A	11/1998	Takahashi
5,772,578 A	6/1998	Heimberger et al.	5,843,021 A	12/1998	Edwards et al.
5,772,659 A	6/1998	Becker et al.	5,843,096 A	12/1998	Igaki et al.
5,773,991 A	6/1998	Chen	5,843,097 A	12/1998	Mayenberger et al.
5,776,130 A	7/1998	Buysse et al.	5,843,122 A	12/1998	Riza
5,778,939 A	7/1998	Hok-Yin	5,843,132 A	12/1998	Ilvento
5,779,130 A	7/1998	Alesi et al.	5,843,169 A	12/1998	Taheri
5,779,131 A	7/1998	Knodel et al.	5,846,254 A	12/1998	Schulze et al.
5,779,132 A	7/1998	Knodel et al.	5,847,566 A	12/1998	Marritt et al.
5,782,396 A	7/1998	Mastri et al.	5,849,011 A	12/1998	Jones et al.
5,782,397 A	7/1998	Koukline	5,849,020 A	12/1998	Long et al.
5,782,748 A	7/1998	Palmer et al.	5,849,023 A	12/1998	Mericle
5,782,749 A	7/1998	Riza	5,851,179 A	12/1998	Ritson et al.
5,782,859 A	7/1998	Nicholas et al.	5,851,212 A	12/1998	Zirps et al.
5,784,934 A	7/1998	Izumisawa	5,853,366 A	12/1998	Dowlatshahi
5,785,232 A	7/1998	Vidal et al.	5,855,311 A	1/1999	Hamblin et al.
5,785,647 A	7/1998	Tompkins et al.	5,855,583 A	1/1999	Wang et al.
5,787,897 A	8/1998	Kieturakis	5,860,581 A	1/1999	Robertson et al.
5,791,231 A	8/1998	Cohn et al.	5,860,975 A	1/1999	Goble et al.
5,792,135 A	8/1998	Madhani et al.	5,865,361 A	2/1999	Milliman et al.
5,792,162 A	8/1998	Jolly et al.	5,865,638 A	2/1999	Trafton
5,792,165 A	8/1998	Klieman et al.	5,868,361 A	2/1999	Rinderer
5,792,573 A	8/1998	Pitzen et al.	5,868,664 A	2/1999	Speier et al.
5,794,834 A	8/1998	Hamblin et al.	5,868,760 A	2/1999	McGuckin, Jr.
5,796,188 A	8/1998	Bays	5,868,790 A	2/1999	Vincent et al.
5,797,536 A	8/1998	Smith et al.	5,871,135 A	2/1999	Williamson, IV et al.
5,797,537 A	8/1998	Oberlin et al.	5,873,885 A	2/1999	Weidenbenner
5,797,538 A	8/1998	Heaton et al.	5,876,401 A	3/1999	Schulze et al.
5,797,637 A	8/1998	Ervin	5,878,193 A	3/1999	Wang et al.
5,797,900 A	8/1998	Madhani et al.	5,878,607 A	3/1999	Nunes et al.
5,797,906 A	8/1998	Rhum et al.	5,878,937 A	3/1999	Green et al.
5,797,927 A	8/1998	Yoon	5,878,938 A	3/1999	Bittner et al.
5,797,941 A	8/1998	Schulze et al.	5,881,777 A	3/1999	Bassi et al.
5,797,959 A	8/1998	Castro et al.	5,881,943 A	3/1999	Heck et al.
5,799,857 A	9/1998	Robertson et al.	5,891,094 A	4/1999	Masterson et al.
5,800,379 A	9/1998	Edwards	5,891,160 A	4/1999	Williamson, IV et al.
5,800,423 A	9/1998	Jensen	5,891,558 A	4/1999	Bell et al.
5,804,726 A	9/1998	Geib et al.	5,893,506 A	4/1999	Powell
5,804,936 A	9/1998	Brodsky et al.	5,893,835 A	4/1999	Witt et al.
5,806,676 A	9/1998	Wasgien	5,893,878 A	4/1999	Pierce
5,807,241 A	9/1998	Heimberger	5,894,979 A	4/1999	Powell
5,807,376 A	9/1998	Viola et al.	5,897,552 A	4/1999	Edwards et al.
5,807,378 A	9/1998	Jensen et al.	5,897,562 A	4/1999	Bolanos et al.
5,807,393 A	9/1998	Williamson, IV et al.	5,899,824 A	5/1999	Kurtz et al.
5,809,441 A	9/1998	McKee	5,899,914 A	5/1999	Zirps et al.
5,810,721 A	9/1998	Mueller et al.	5,901,895 A	5/1999	Heaton et al.
5,810,811 A	9/1998	Yates et al.	5,902,312 A	5/1999	Frater et al.
5,810,846 A	9/1998	Virnich et al.	5,903,117 A	5/1999	Gregory
5,810,855 A	9/1998	Rayburn et al.	5,904,647 A	5/1999	Ouchi
5,812,188 A	9/1998	Adair	5,904,693 A	5/1999	Dicesare et al.
5,813,813 A	9/1998	Daum et al.	5,904,702 A	5/1999	Ek et al.
5,814,055 A	9/1998	Knodel et al.	5,906,577 A	5/1999	Beane et al.
5,814,057 A	9/1998	Oi et al.	5,906,625 A	5/1999	Bito et al.
5,816,471 A	10/1998	Plyley et al.	5,907,211 A	5/1999	Hall et al.
5,817,084 A	10/1998	Jensen	5,907,664 A	5/1999	Wang et al.
5,817,091 A	10/1998	Nardella et al.	5,908,402 A	6/1999	Blythe
5,817,093 A	10/1998	Williamson, IV et al.	5,908,427 A	6/1999	McKean et al.
5,817,109 A	10/1998	McGarry et al.	5,909,062 A	6/1999	Krietzman
5,817,119 A	10/1998	Klieman et al.	5,911,353 A	6/1999	Bolanos et al.
5,820,009 A	10/1998	Melling et al.	5,915,616 A	6/1999	Viola et al.
			5,916,225 A	6/1999	Kugel
			5,918,791 A	7/1999	Sorrentino et al.
			5,919,198 A	7/1999	Graves, Jr. et al.
			5,921,956 A	7/1999	Grinberg et al.

(56)

References Cited

U.S. PATENT DOCUMENTS

5,924,864 A	7/1999	Loge et al.	6,037,927 A	3/2000	Rosenberg
5,928,137 A	7/1999	Green	6,039,126 A	3/2000	Hsieh
5,928,256 A	7/1999	Riza	6,039,733 A	3/2000	Buysse et al.
5,931,847 A	8/1999	Bittner et al.	6,039,734 A	3/2000	Goble
5,931,853 A	8/1999	McEwen et al.	6,042,601 A	3/2000	Smith
5,937,951 A	8/1999	Izuchukwu et al.	6,042,607 A	3/2000	Williamson, IV et al.
5,938,667 A	8/1999	Peysen et al.	6,043,626 A	3/2000	Snyder et al.
5,941,442 A	8/1999	Geiste et al.	6,045,560 A	4/2000	McKean et al.
5,941,890 A	8/1999	Voegele et al.	6,047,861 A	4/2000	Vidal et al.
5,944,172 A	8/1999	Hannula	6,049,145 A	4/2000	Austin et al.
5,944,715 A	8/1999	Goble et al.	6,050,172 A	4/2000	Corves et al.
5,946,978 A	9/1999	Yamashita	6,050,472 A	4/2000	Shibata
5,947,984 A	9/1999	Whipple	6,050,989 A	4/2000	Fox et al.
5,947,996 A	9/1999	Logeman	6,050,990 A	4/2000	Tankovich et al.
5,948,030 A	9/1999	Miller et al.	6,050,996 A	4/2000	Schmaltz et al.
5,948,429 A	9/1999	Bell et al.	6,053,390 A	4/2000	Green et al.
5,951,301 A	9/1999	Younker	6,053,899 A	4/2000	Slanda et al.
5,951,516 A	9/1999	Bunyan	6,053,922 A	4/2000	Krause et al.
5,951,552 A	9/1999	Long et al.	6,054,142 A	4/2000	Li et al.
5,951,574 A	9/1999	Stefanchik et al.	6,055,062 A	4/2000	Dina et al.
5,951,575 A	9/1999	Bolduc et al.	RE36,720 E	5/2000	Green et al.
5,951,581 A	9/1999	Saadat et al.	6,056,735 A	5/2000	Okada et al.
5,954,259 A	9/1999	Viola et al.	6,056,746 A	5/2000	Goble et al.
5,957,831 A	9/1999	Adair	6,059,806 A	5/2000	Hoegerle
5,964,394 A	10/1999	Robertson	6,062,360 A	5/2000	Shields
5,964,774 A	10/1999	McKean et al.	6,063,020 A	5/2000	Jones et al.
5,966,126 A	10/1999	Szabo	6,063,025 A	5/2000	Bridges et al.
5,971,916 A	10/1999	Koren	6,063,050 A	5/2000	Manna et al.
5,973,221 A	10/1999	Collyer et al.	6,063,095 A	5/2000	Wang et al.
D416,089 S	11/1999	Barton et al.	6,063,097 A	5/2000	Oi et al.
5,976,122 A	11/1999	Madhani et al.	6,063,098 A	5/2000	Houser et al.
5,977,746 A	11/1999	Hershberger et al.	6,065,679 A	5/2000	Levie et al.
5,980,248 A	11/1999	Kusakabe et al.	6,065,919 A	5/2000	Peck
5,984,949 A	11/1999	Levin	6,066,132 A	5/2000	Chen et al.
5,988,479 A	11/1999	Palmer	6,066,151 A	5/2000	Miyawaki et al.
5,990,379 A	11/1999	Gregory	6,068,627 A	5/2000	Orszulak et al.
5,993,466 A	11/1999	Yoon	6,071,233 A	6/2000	Ishikawa et al.
5,997,528 A	12/1999	Bisch et al.	6,072,299 A	6/2000	Kurle et al.
5,997,552 A	12/1999	Person et al.	6,074,386 A	6/2000	Goble et al.
6,001,108 A	12/1999	Wang et al.	6,074,401 A	6/2000	Gardiner et al.
6,003,517 A	12/1999	Sheffield et al.	6,075,441 A	6/2000	Maloney
6,004,319 A	12/1999	Goble et al.	6,077,280 A	6/2000	Fossum
6,004,335 A	12/1999	Vaitekunas et al.	6,077,286 A	6/2000	Cuschieri et al.
6,007,521 A	12/1999	Bidwell et al.	6,077,290 A	6/2000	Marini
6,010,054 A	1/2000	Johnson et al.	6,079,606 A	6/2000	Milliman et al.
6,010,513 A	1/2000	Tormala et al.	6,080,181 A	6/2000	Jensen et al.
6,010,520 A	1/2000	Pattison	6,082,577 A	7/2000	Coates et al.
6,012,494 A	1/2000	Balazs	6,083,191 A	7/2000	Rose
6,013,076 A	1/2000	Goble et al.	6,083,223 A	7/2000	Baker
6,013,991 A	1/2000	Philipp	6,083,234 A	7/2000	Nicholas et al.
6,015,406 A	1/2000	Goble et al.	6,083,242 A	7/2000	Cook
6,015,417 A	1/2000	Reynolds, Jr.	6,086,544 A	7/2000	Hibner et al.
6,017,322 A	1/2000	Snoke et al.	6,086,600 A	7/2000	Kortenbach
6,017,354 A	1/2000	Culp et al.	6,090,106 A	7/2000	Goble et al.
6,017,356 A	1/2000	Frederick et al.	6,090,123 A	7/2000	Culp et al.
6,018,227 A	1/2000	Kumar et al.	6,093,186 A	7/2000	Goble
6,019,745 A	2/2000	Gray	6,094,021 A	7/2000	Noro et al.
6,019,780 A	2/2000	Lombardo et al.	D429,252 S	8/2000	Haitani et al.
6,022,352 A	2/2000	Vandewalle	6,099,537 A	8/2000	Sugai et al.
6,023,641 A	2/2000	Thompson	6,099,551 A	8/2000	Gabbay
6,024,708 A	2/2000	Bales et al.	6,102,271 A	8/2000	Longo et al.
6,024,741 A	2/2000	Williamson, IV et al.	6,102,926 A	8/2000	Tartaglia et al.
6,024,748 A	2/2000	Manzo et al.	6,104,162 A	8/2000	Sainsbury et al.
6,024,750 A	2/2000	Mastri et al.	6,104,304 A	8/2000	Clark et al.
6,024,764 A	2/2000	Schroepfel	6,106,511 A	8/2000	Jensen
6,027,501 A	2/2000	Goble et al.	6,109,500 A	8/2000	Alli et al.
6,030,384 A	2/2000	Nezhat	6,110,187 A	8/2000	Donlon
6,032,849 A	3/2000	Mastri et al.	6,113,618 A	9/2000	Nic
6,033,105 A	3/2000	Barker et al.	6,117,148 A	9/2000	Ravo et al.
6,033,378 A	3/2000	Lundquist et al.	6,117,158 A	9/2000	Measamer et al.
6,033,399 A	3/2000	Gines	6,119,913 A	9/2000	Adams et al.
6,033,427 A	3/2000	Lee	6,120,433 A	9/2000	Mizuno et al.
6,036,641 A	3/2000	Taylor et al.	6,120,462 A	9/2000	Hibner et al.
6,036,667 A	3/2000	Manna et al.	6,123,241 A	9/2000	Walter et al.
6,037,724 A	3/2000	Buss et al.	6,123,701 A	9/2000	Nezhat
			H1904 H	10/2000	Yates et al.
			RE36,923 E	10/2000	Hiroi et al.
			6,126,058 A	10/2000	Adams et al.
			6,126,359 A	10/2000	Dittrich et al.

(56)

References Cited

U.S. PATENT DOCUMENTS

6,126,670	A	10/2000	Walker et al.	6,241,723	B1	6/2001	Heim et al.
6,131,789	A	10/2000	Schulze et al.	6,245,084	B1	6/2001	Mark et al.
6,131,790	A	10/2000	Piraka	6,248,116	B1	6/2001	Chevillon et al.
6,132,368	A	10/2000	Cooper	6,248,117	B1	6/2001	Blatter
6,134,962	A	10/2000	Sugitani	6,249,076	B1	6/2001	Madden et al.
6,139,546	A	10/2000	Koenig et al.	6,249,105	B1	6/2001	Andrews et al.
6,142,149	A	11/2000	Steen	6,250,532	B1	6/2001	Green et al.
6,142,933	A	11/2000	Longo et al.	6,251,485	B1	6/2001	Harris et al.
6,147,135	A	11/2000	Yuan et al.	D445,745	S	7/2001	Norman
6,149,660	A	11/2000	Laufer et al.	6,254,534	B1	7/2001	Butler et al.
6,151,323	A	11/2000	O'Connell et al.	6,254,619	B1	7/2001	Garabet et al.
6,152,935	A	11/2000	Kammerer et al.	6,254,642	B1	7/2001	Taylor
6,155,473	A	12/2000	Tompkins et al.	6,258,107	B1	7/2001	Balazs et al.
6,156,056	A	12/2000	Kearns et al.	6,261,246	B1	7/2001	Pantages et al.
6,157,169	A	12/2000	Lee	6,261,286	B1	7/2001	Goble et al.
6,159,146	A	12/2000	El Gazayerli	6,261,679	B1	7/2001	Chen et al.
6,159,200	A	12/2000	Verdura et al.	6,264,086	B1	7/2001	McGuckin, Jr.
6,159,224	A	12/2000	Yoon	6,264,087	B1	7/2001	Whitman
6,162,208	A	12/2000	Hipps	6,264,617	B1	7/2001	Bales et al.
6,162,220	A	12/2000	Nezhat	6,269,997	B1	8/2001	Balazs et al.
6,162,537	A	12/2000	Martin et al.	6,270,508	B1	8/2001	Klieman et al.
6,165,175	A	12/2000	Wampler et al.	6,270,916	B1	8/2001	Sink et al.
6,165,184	A	12/2000	Verdura et al.	6,273,252	B1	8/2001	Mitchell
6,165,188	A	12/2000	Saadat et al.	6,273,876	B1	8/2001	Klima et al.
6,167,185	A	12/2000	Smiley et al.	6,273,897	B1	8/2001	Dalessandro et al.
6,168,605	B1	1/2001	Measamer et al.	6,277,114	B1	8/2001	Bullivant et al.
6,171,305	B1	1/2001	Sherman	6,280,407	B1	8/2001	Manna et al.
6,171,316	B1	1/2001	Kovac et al.	6,283,981	B1	9/2001	Beaupre
6,171,330	B1	1/2001	Benchetrit	6,293,927	B1	9/2001	McGuckin, Jr.
6,173,074	B1	1/2001	Russo	6,293,942	B1	9/2001	Goble et al.
6,174,308	B1	1/2001	Goble et al.	6,296,640	B1	10/2001	Wampler et al.
6,174,309	B1	1/2001	Wrublewski et al.	6,302,311	B1	10/2001	Adams et al.
6,174,318	B1	1/2001	Bates et al.	6,302,743	B1	10/2001	Chiu et al.
6,175,290	B1	1/2001	Forsythe et al.	6,305,891	B1	10/2001	Burlingame
6,179,195	B1	1/2001	Adams et al.	6,306,134	B1	10/2001	Goble et al.
6,179,776	B1	1/2001	Adams et al.	6,306,149	B1	10/2001	Meade
6,181,105	B1	1/2001	Cutolo et al.	6,306,424	B1	10/2001	Vyakarnam et al.
6,182,673	B1	2/2001	Kindermann et al.	6,309,397	B1	10/2001	Julian et al.
6,185,356	B1	2/2001	Parker et al.	6,309,400	B2	10/2001	Beaupre
6,186,142	B1	2/2001	Schmidt et al.	6,309,403	B1	10/2001	Minor et al.
6,186,957	B1	2/2001	Milam	6,312,435	B1	11/2001	Wallace et al.
6,187,003	B1	2/2001	Buyse et al.	6,315,184	B1	11/2001	Whitman
6,190,386	B1	2/2001	Rydell	6,317,616	B1	11/2001	Glossop
6,193,129	B1	2/2001	Bittner et al.	6,319,510	B1	11/2001	Yates
6,197,042	B1	3/2001	Ginn et al.	6,320,123	B1	11/2001	Reimers
6,200,311	B1	3/2001	Danek et al.	6,322,494	B1	11/2001	Bullivant et al.
6,200,330	B1	3/2001	Benderev et al.	6,324,339	B1	11/2001	Hudson et al.
6,202,914	B1	3/2001	Geiste et al.	6,325,799	B1	12/2001	Goble
6,206,894	B1	3/2001	Thompson et al.	6,325,805	B1	12/2001	Ogilvie et al.
6,206,897	B1	3/2001	Jamiolkowski et al.	6,325,810	B1	12/2001	Hamilton et al.
6,206,903	B1	3/2001	Ramans	6,328,498	B1	12/2001	Mersch
6,206,904	B1	3/2001	Ouchi	6,330,965	B1	12/2001	Milliman et al.
6,209,414	B1	4/2001	Uneme	6,331,181	B1	12/2001	Tierney et al.
6,210,403	B1	4/2001	Klicek	6,331,761	B1	12/2001	Kumar et al.
6,211,626	B1	4/2001	Lys et al.	6,333,029	B1	12/2001	Vyakarnam et al.
6,213,999	B1	4/2001	Platt, Jr. et al.	6,334,860	B1	1/2002	Dorn
6,214,028	B1	4/2001	Yoon et al.	6,334,861	B1	1/2002	Chandler et al.
6,220,368	B1	4/2001	Ark et al.	6,336,926	B1	1/2002	Goble
6,221,007	B1	4/2001	Green	6,338,737	B1	1/2002	Toledano
6,221,023	B1	4/2001	Matsuba et al.	6,343,731	B1	2/2002	Adams et al.
6,223,100	B1	4/2001	Green	6,346,077	B1	2/2002	Taylor et al.
6,223,835	B1	5/2001	Habedank et al.	6,348,061	B1	2/2002	Whitman
6,224,617	B1	5/2001	Saadat et al.	6,349,868	B1	2/2002	Mattingly et al.
6,228,080	B1	5/2001	Gines	D454,951	S	3/2002	Bon
6,228,081	B1	5/2001	Goble	6,352,503	B1	3/2002	Matsui et al.
6,228,083	B1	5/2001	Lands et al.	6,352,532	B1	3/2002	Kramer et al.
6,228,084	B1	5/2001	Kirwan, Jr.	6,355,699	B1	3/2002	Vyakarnam et al.
6,228,089	B1	5/2001	Wahrburg	6,356,072	B1	3/2002	Chass
6,228,098	B1	5/2001	Kayan et al.	6,358,224	B1	3/2002	Tims et al.
6,231,565	B1	5/2001	Tovey et al.	6,358,263	B2	3/2002	Mark et al.
6,234,178	B1	5/2001	Goble et al.	6,358,459	B1	3/2002	Ziegler et al.
6,237,604	B1	5/2001	Burnside et al.	6,361,542	B1	3/2002	Dimitriu et al.
6,238,384	B1	5/2001	Peer	6,364,828	B1	4/2002	Yeung et al.
6,241,139	B1	6/2001	Milliman et al.	6,364,877	B1	4/2002	Goble et al.
6,241,140	B1	6/2001	Adams et al.	6,364,888	B1	4/2002	Niemeyer et al.
				6,366,441	B1	4/2002	Ozawa et al.
				6,370,981	B2	4/2002	Watarai
				6,371,114	B1	4/2002	Schmidt et al.
				6,373,152	B1	4/2002	Wang et al.

(56)

References Cited

U.S. PATENT DOCUMENTS

6,377,011	B1	4/2002	Ben-Ur	6,492,785	B1	12/2002	Kasten et al.
6,383,201	B1	5/2002	Dong	6,494,882	B1	12/2002	Lebouitz et al.
6,387,092	B1	5/2002	Burnside et al.	6,494,885	B1	12/2002	Dhindsa
6,387,113	B1	5/2002	Hawkins et al.	6,494,888	B1	12/2002	Laufer et al.
6,387,114	B2	5/2002	Adams	6,494,896	B1	12/2002	D'Alessio et al.
6,391,038	B2	5/2002	Vargas et al.	6,498,480	B1	12/2002	Manara
6,392,854	B1	5/2002	O'Gorman	6,500,176	B1	12/2002	Truckai et al.
6,394,998	B1	5/2002	Wallace et al.	6,500,189	B1	12/2002	Lang et al.
6,398,779	B1	6/2002	Buysse et al.	6,500,194	B2	12/2002	Benderev et al.
6,398,781	B1	6/2002	Goble et al.	D468,749	S	1/2003	Friedman
6,398,797	B2	6/2002	Bombard et al.	6,503,139	B2	1/2003	Coral
6,402,766	B2	6/2002	Bowman et al.	6,503,257	B2	1/2003	Grant et al.
6,402,780	B2	6/2002	Williamson, IV et al.	6,503,259	B2	1/2003	Huxel et al.
6,406,440	B1	6/2002	Stefanchik	6,505,768	B2	1/2003	Whitman
6,406,472	B1	6/2002	Jensen	6,506,197	B1	1/2003	Rollero et al.
6,409,724	B1	6/2002	Penny et al.	6,506,399	B2	1/2003	Donovan
H2037	H	7/2002	Yates et al.	6,510,854	B2	1/2003	Goble
6,412,639	B1	7/2002	Hickey	6,511,468	B1	1/2003	Cragg et al.
6,413,274	B1	7/2002	Pedros	6,512,360	B1	1/2003	Goto et al.
6,415,542	B1	7/2002	Bates et al.	6,514,252	B2	2/2003	Nezhat et al.
6,416,486	B1	7/2002	Wampler	6,516,073	B1	2/2003	Schulz et al.
6,416,509	B1	7/2002	Goble et al.	6,517,528	B1	2/2003	Pantages et al.
6,419,695	B1	7/2002	Gabbay	6,517,535	B2	2/2003	Edwards
6,423,079	B1	7/2002	Blake, III	6,517,565	B1	2/2003	Whitman et al.
6,424,885	B1	7/2002	Niemeyer et al.	6,517,566	B1	2/2003	Hovland et al.
RE37,814	E	8/2002	Allgeyer	6,520,971	B1	2/2003	Perry et al.
6,428,070	B1	8/2002	Takanashi et al.	6,520,972	B2	2/2003	Peters
6,428,487	B1	8/2002	Burdorff et al.	6,522,101	B2	2/2003	Malackowski
6,429,611	B1	8/2002	Li	6,524,180	B1	2/2003	Simms et al.
6,430,298	B1	8/2002	Ketttl et al.	6,525,499	B2	2/2003	Naganuma
6,432,065	B1	8/2002	Burdorff et al.	D471,206	S	3/2003	Buzzard et al.
6,436,097	B1	8/2002	Nardella	6,527,782	B2	3/2003	Hogg et al.
6,436,107	B1	8/2002	Wang et al.	6,527,785	B2	3/2003	Sancoff et al.
6,436,110	B2	8/2002	Bowman et al.	6,530,942	B2	3/2003	Fogarty et al.
6,436,115	B1	8/2002	Beaupre	6,532,958	B1	3/2003	Buan et al.
6,436,122	B1	8/2002	Frank et al.	6,533,157	B1	3/2003	Whitman
6,439,439	B1	8/2002	Rickard et al.	6,533,723	B1	3/2003	Lockery et al.
6,439,446	B1	8/2002	Perry et al.	6,533,784	B2	3/2003	Truckai et al.
6,440,146	B2	8/2002	Nicholas et al.	6,535,764	B2	3/2003	Imran et al.
6,441,577	B2	8/2002	Blumenkranz et al.	6,539,297	B2	3/2003	Weiberle et al.
D462,758	S	9/2002	Epstein et al.	D473,239	S	4/2003	Cockerill
6,443,973	B1	9/2002	Whitman	6,539,816	B2	4/2003	Kogiso et al.
6,445,530	B1	9/2002	Baker	6,540,737	B2	4/2003	Bacher et al.
6,447,518	B1	9/2002	Krause et al.	6,543,456	B1	4/2003	Freeman
6,447,523	B1	9/2002	Middleman et al.	6,545,384	B1	4/2003	Pelrine et al.
6,447,799	B1	9/2002	Ullman	6,547,786	B1	4/2003	Goble
6,447,864	B2	9/2002	Johnson et al.	6,550,546	B2	4/2003	Thurler et al.
6,450,391	B1	9/2002	Kayan et al.	6,551,333	B2	4/2003	Kuhns et al.
6,450,989	B2	9/2002	Dubrul et al.	6,554,844	B2	4/2003	Lee et al.
6,454,781	B1	9/2002	Witt et al.	6,554,861	B2	4/2003	Knox et al.
6,457,338	B1	10/2002	Frenken	6,555,770	B2	4/2003	Kawase
6,457,625	B1	10/2002	Tormala et al.	6,558,378	B2	5/2003	Sherman et al.
6,458,077	B1	10/2002	Boebel et al.	6,558,379	B1	5/2003	Batchelor et al.
6,458,142	B1	10/2002	Faller et al.	6,558,429	B2	5/2003	Taylor
6,458,147	B1	10/2002	Cruise et al.	6,561,187	B2	5/2003	Schmidt et al.
6,460,627	B1	10/2002	Below et al.	6,565,560	B1	5/2003	Goble et al.
6,468,275	B1	10/2002	Wampler et al.	6,566,619	B2	5/2003	Gillman et al.
6,468,286	B2	10/2002	Mastri et al.	6,569,085	B2	5/2003	Kortenbach et al.
6,471,106	B1	10/2002	Reining	6,569,171	B2	5/2003	DeGuillebon et al.
6,471,659	B2	10/2002	Eggers et al.	6,572,629	B2	6/2003	Kaloo et al.
6,478,210	B2	11/2002	Adams et al.	6,578,751	B2	6/2003	Hartwick
6,482,063	B1	11/2002	Frigard	6,582,364	B2	6/2003	Butler et al.
6,482,200	B2	11/2002	Shippert	6,582,427	B1	6/2003	Goble et al.
6,482,217	B1	11/2002	Pintor et al.	6,582,441	B1	6/2003	He et al.
6,485,490	B2	11/2002	Wampler et al.	6,583,533	B2	6/2003	Pelrine et al.
6,485,503	B2	11/2002	Jacobs et al.	6,585,144	B2	7/2003	Adams et al.
6,485,667	B1	11/2002	Tan	6,585,664	B2	7/2003	Burdorff et al.
6,486,286	B1	11/2002	McGall et al.	6,586,898	B2	7/2003	King et al.
6,488,196	B1	12/2002	Fenton, Jr.	6,587,750	B2	7/2003	Gerbi et al.
6,488,197	B1	12/2002	Whitman	6,588,277	B2	7/2003	Giordano et al.
6,488,659	B1	12/2002	Rosenman	6,588,643	B2	7/2003	Bolduc et al.
6,491,201	B1	12/2002	Whitman	6,588,931	B2	7/2003	Betzner et al.
6,491,690	B1	12/2002	Goble et al.	6,589,118	B1	7/2003	Soma et al.
6,491,701	B2	12/2002	Tierney et al.	6,589,164	B1	7/2003	Flaherty
6,491,702	B2	12/2002	Heilbrun et al.	6,592,538	B1	7/2003	Hotchkiss et al.
				6,592,572	B1	7/2003	Suzuta
				6,592,597	B2	7/2003	Grant et al.
				6,594,552	B1	7/2003	Nowlin et al.
				6,595,914	B2	7/2003	Kato

(56)

References Cited

U.S. PATENT DOCUMENTS

- | | | | | | |
|--------------|---------|----------------------|--------------|--------|---------------------|
| 6,596,296 B1 | 7/2003 | Nelson et al. | 6,695,774 B2 | 2/2004 | Hale et al. |
| 6,596,304 B1 | 7/2003 | Bayon et al. | 6,695,849 B2 | 2/2004 | Michelson |
| 6,596,432 B2 | 7/2003 | Kawakami et al. | 6,696,814 B2 | 2/2004 | Henderson et al. |
| 6,599,295 B1 | 7/2003 | Tornier et al. | 6,697,048 B2 | 2/2004 | Rosenberg et al. |
| 6,599,323 B2 | 7/2003 | Melican et al. | 6,698,643 B2 | 3/2004 | Whitman |
| D478,665 S | 8/2003 | Isaacs et al. | 6,699,177 B1 | 3/2004 | Wang et al. |
| D478,986 S | 8/2003 | Johnston et al. | 6,699,214 B2 | 3/2004 | Gellman |
| 6,601,749 B2 | 8/2003 | Sullivan et al. | 6,699,235 B2 | 3/2004 | Wallace et al. |
| 6,602,252 B2 | 8/2003 | Mollenauer | 6,704,210 B1 | 3/2004 | Myers |
| 6,602,262 B2 | 8/2003 | Griego et al. | 6,705,503 B1 | 3/2004 | Pedicini et al. |
| 6,603,050 B2 | 8/2003 | Heaton | 6,709,445 B2 | 3/2004 | Boebel et al. |
| 6,605,078 B2 | 8/2003 | Adams | 6,712,773 B1 | 3/2004 | Viola |
| 6,605,669 B2 | 8/2003 | Awokola et al. | 6,716,215 B1 | 4/2004 | David et al. |
| 6,605,911 B1 | 8/2003 | Klesing | 6,716,223 B2 | 4/2004 | Leopold et al. |
| 6,607,475 B2 | 8/2003 | Doyle et al. | 6,716,232 B1 | 4/2004 | Vidal et al. |
| 6,611,793 B1 | 8/2003 | Burnside et al. | 6,716,233 B1 | 4/2004 | Whitman |
| 6,613,069 B2 | 9/2003 | Boyd et al. | 6,720,734 B2 | 4/2004 | Norris |
| 6,616,686 B2 | 9/2003 | Coleman et al. | 6,722,550 B1 | 4/2004 | Ricordi et al. |
| 6,619,529 B2 | 9/2003 | Green et al. | 6,722,552 B2 | 4/2004 | Fenton, Jr. |
| 6,620,111 B2 | 9/2003 | Stephens et al. | 6,723,087 B2 | 4/2004 | O'Neill et al. |
| 6,620,161 B2 | 9/2003 | Schulze et al. | 6,723,091 B2 | 4/2004 | Goble et al. |
| 6,620,166 B1 | 9/2003 | Wenstrom, Jr. et al. | 6,723,106 B1 | 4/2004 | Charles et al. |
| 6,625,517 B1 | 9/2003 | Bogdanov et al. | 6,723,109 B2 | 4/2004 | Solingen |
| 6,626,834 B2 | 9/2003 | Dunne et al. | 6,726,651 B1 | 4/2004 | Robinson et al. |
| 6,626,938 B1 | 9/2003 | Butaric et al. | 6,726,697 B2 | 4/2004 | Nicholas et al. |
| H2086 H | 10/2003 | Amsler | 6,726,705 B2 | 4/2004 | Peterson et al. |
| 6,629,630 B2 | 10/2003 | Adams | 6,726,706 B2 | 4/2004 | Dominguez |
| 6,629,974 B2 | 10/2003 | Penny et al. | 6,729,119 B2 | 5/2004 | Schnipke et al. |
| 6,629,988 B2 | 10/2003 | Weadock | 6,731,976 B2 | 5/2004 | Penn et al. |
| 6,635,838 B1 | 10/2003 | Kornelson | 6,736,810 B2 | 5/2004 | Hoey et al. |
| 6,636,412 B2 | 10/2003 | Smith | 6,736,825 B2 | 5/2004 | Blatter et al. |
| 6,638,108 B2 | 10/2003 | Tachi | 6,736,854 B2 | 5/2004 | Vadurro et al. |
| 6,638,285 B2 | 10/2003 | Gabbay | 6,740,030 B2 | 5/2004 | Martone et al. |
| 6,638,297 B1 | 10/2003 | Huitema | 6,743,230 B2 | 6/2004 | Lutze et al. |
| RE38,335 E | 11/2003 | Aust et al. | 6,744,385 B2 | 6/2004 | Kazuya et al. |
| 6,641,528 B2 | 11/2003 | Torii | 6,747,121 B2 | 6/2004 | Gogolewski |
| 6,644,532 B2 | 11/2003 | Green et al. | 6,747,300 B2 | 6/2004 | Nadd et al. |
| 6,645,201 B1 | 11/2003 | Utley et al. | 6,749,560 B1 | 6/2004 | Konstorum et al. |
| 6,646,307 B1 | 11/2003 | Yu et al. | 6,749,600 B1 | 6/2004 | Levy |
| 6,648,816 B2 | 11/2003 | Irion et al. | 6,752,768 B2 | 6/2004 | Burdorff et al. |
| 6,648,901 B2 | 11/2003 | Fleischman et al. | 6,752,816 B2 | 6/2004 | Culp et al. |
| 6,652,595 B1 | 11/2003 | Nicolo | 6,754,959 B1 | 6/2004 | Guiette, III et al. |
| D484,243 S | 12/2003 | Ryan et al. | 6,755,195 B1 | 6/2004 | Lemke et al. |
| D484,595 S | 12/2003 | Ryan et al. | 6,755,338 B2 | 6/2004 | Hahnen et al. |
| D484,596 S | 12/2003 | Ryan et al. | 6,755,825 B2 | 6/2004 | Shoenman et al. |
| 6,656,177 B2 | 12/2003 | Truckai et al. | 6,755,843 B2 | 6/2004 | Chung et al. |
| 6,656,193 B2 | 12/2003 | Grant et al. | 6,756,705 B2 | 6/2004 | Pulford, Jr. |
| 6,659,940 B2 | 12/2003 | Adler | 6,758,846 B2 | 7/2004 | Goble et al. |
| 6,660,008 B1 | 12/2003 | Foerster et al. | 6,761,685 B2 | 7/2004 | Adams et al. |
| 6,663,623 B1 | 12/2003 | Oyama et al. | 6,762,339 B1 | 7/2004 | Klun et al. |
| 6,663,641 B1 | 12/2003 | Kovac et al. | 6,763,307 B2 | 7/2004 | Berg et al. |
| 6,666,854 B1 | 12/2003 | Lange | 6,764,445 B2 | 7/2004 | Ramans et al. |
| 6,666,860 B1 | 12/2003 | Takahashi | 6,766,957 B2 | 7/2004 | Matsuura et al. |
| 6,666,875 B1 | 12/2003 | Sakurai et al. | 6,767,352 B2 | 7/2004 | Field et al. |
| 6,667,825 B2 | 12/2003 | Lu et al. | 6,767,356 B2 | 7/2004 | Kanner et al. |
| 6,669,073 B2 | 12/2003 | Milliman et al. | 6,769,590 B2 | 8/2004 | Vresh et al. |
| 6,670,806 B2 | 12/2003 | Wendt et al. | 6,769,594 B2 | 8/2004 | Orban, III |
| 6,671,185 B2 | 12/2003 | Duval | 6,770,027 B2 | 8/2004 | Banik et al. |
| D484,977 S | 1/2004 | Ryan et al. | 6,770,070 B1 | 8/2004 | Balbierz |
| 6,676,660 B2 | 1/2004 | Wampler et al. | 6,770,072 B1 | 8/2004 | Truckai et al. |
| 6,677,687 B2 | 1/2004 | Ho et al. | 6,770,078 B2 | 8/2004 | Bonutti |
| 6,679,269 B2 | 1/2004 | Swanson | 6,773,409 B2 | 8/2004 | Truckai et al. |
| 6,679,410 B2 | 1/2004 | Wursch et al. | 6,773,437 B2 | 8/2004 | Ogilvie et al. |
| 6,681,978 B2 | 1/2004 | Geiste et al. | 6,773,438 B1 | 8/2004 | Knodel et al. |
| 6,681,979 B2 | 1/2004 | Whitman | 6,775,575 B2 | 8/2004 | Bommannan et al. |
| 6,682,527 B2 | 1/2004 | Strul | 6,777,838 B2 | 8/2004 | Miekka et al. |
| 6,682,528 B2 | 1/2004 | Frazier et al. | 6,778,846 B1 | 8/2004 | Martinez et al. |
| 6,682,544 B2 | 1/2004 | Mastri et al. | 6,780,151 B2 | 8/2004 | Grabover et al. |
| 6,685,698 B2 | 2/2004 | Morley et al. | 6,780,180 B1 | 8/2004 | Goble et al. |
| 6,685,727 B2 | 2/2004 | Fisher et al. | 6,783,524 B2 | 8/2004 | Anderson et al. |
| 6,689,153 B1 | 2/2004 | Skiba | 6,784,775 B2 | 8/2004 | Mandell et al. |
| 6,692,507 B2 | 2/2004 | Pugsley et al. | 6,786,382 B1 | 9/2004 | Hoffman |
| 6,692,692 B2 | 2/2004 | Stetzel | 6,786,864 B2 | 9/2004 | Matsuura et al. |
| 6,695,198 B2 | 2/2004 | Adams et al. | 6,786,896 B1 | 9/2004 | Madhani et al. |
| 6,695,199 B2 | 2/2004 | Whitman | 6,788,018 B1 | 9/2004 | Blumenkranz |
| | | | 6,790,173 B2 | 9/2004 | Saadat et al. |
| | | | 6,793,652 B1 | 9/2004 | Whitman et al. |
| | | | 6,793,661 B2 | 9/2004 | Hamilton et al. |
| | | | 6,793,663 B2 | 9/2004 | Kneifel et al. |

(56)

References Cited

U.S. PATENT DOCUMENTS

6,793,669 B2	9/2004	Nakamura et al.	6,884,428 B2	4/2005	Binette et al.
6,796,921 B1	9/2004	Buck et al.	6,886,730 B2	5/2005	Fujisawa et al.
6,799,669 B2	10/2004	Fukumura et al.	6,887,244 B1	5/2005	Walker et al.
6,801,009 B2	10/2004	Makaran et al.	6,887,710 B2	5/2005	Call et al.
6,802,822 B1	10/2004	Dodge	6,889,116 B2	5/2005	Jinno
6,802,843 B2	10/2004	Truckai et al.	6,893,435 B2	5/2005	Goble
6,802,844 B2	10/2004	Ferree	6,894,140 B2	5/2005	Roby
6,805,273 B2	10/2004	Bilotti et al.	6,895,176 B2	5/2005	Archer et al.
6,806,808 B1	10/2004	Watters et al.	6,899,538 B2	5/2005	Matoba
6,806,867 B1	10/2004	Arruda et al.	6,899,593 B1	5/2005	Moeller et al.
6,808,525 B2	10/2004	Latterell et al.	6,899,705 B2	5/2005	Niemeyer
6,810,359 B2	10/2004	Sakaguchi	6,899,915 B2	5/2005	Yelick et al.
6,814,154 B2	11/2004	Chou	6,905,057 B2	6/2005	Swayze et al.
6,814,741 B2	11/2004	Bowman et al.	6,905,497 B2	6/2005	Truckai et al.
6,817,508 B1	11/2004	Racenet et al.	6,905,498 B2	6/2005	Hooven
6,817,509 B2	11/2004	Geiste et al.	6,908,472 B2	6/2005	Wiener et al.
6,817,974 B2	11/2004	Cooper et al.	6,911,033 B2	6/2005	de Guillebon et al.
6,818,018 B1	11/2004	Sawhney	6,911,916 B1	6/2005	Wang et al.
6,820,791 B2	11/2004	Adams	6,913,579 B2	7/2005	Truckai et al.
6,821,273 B2	11/2004	Mollenauer	6,913,608 B2	7/2005	Liddicoat et al.
6,821,282 B2	11/2004	Perry et al.	6,913,613 B2	7/2005	Schwarz et al.
6,821,284 B2	11/2004	Sturtz et al.	6,921,397 B2	7/2005	Corcoran et al.
6,827,246 B2	12/2004	Sullivan et al.	6,921,412 B1	7/2005	Black et al.
6,827,712 B2	12/2004	Tovey et al.	6,923,093 B2	8/2005	Ullah
6,827,725 B2	12/2004	Batchelor et al.	6,923,803 B2	8/2005	Goble
6,828,902 B2	12/2004	Casden	6,923,819 B2	8/2005	Meade et al.
6,830,174 B2	12/2004	Hillstead et al.	6,925,849 B2	8/2005	Jairam
6,831,629 B2	12/2004	Nishino et al.	6,926,716 B2	8/2005	Baker et al.
6,832,998 B2	12/2004	Goble	6,928,902 B1	8/2005	Eyssallenne
6,834,001 B2	12/2004	Myono	6,929,641 B2	8/2005	Goble et al.
6,835,173 B2	12/2004	Couvillon, Jr.	6,929,644 B2	8/2005	Truckai et al.
6,835,199 B2	12/2004	McGuckin, Jr. et al.	6,931,830 B2	8/2005	Liao
6,835,336 B2	12/2004	Watt	6,932,218 B2	8/2005	Kosann et al.
6,836,611 B2	12/2004	Popovic et al.	6,932,810 B2	8/2005	Ryan
6,837,846 B2	1/2005	Jaffe et al.	6,936,042 B2	8/2005	Wallace et al.
6,837,883 B2	1/2005	Moll et al.	6,936,948 B2	8/2005	Bell et al.
6,838,493 B2	1/2005	Williams et al.	D509,297 S	9/2005	Wells
6,840,423 B2	1/2005	Adams et al.	D509,589 S	9/2005	Wells
6,840,938 B1	1/2005	Morley et al.	6,938,706 B2	9/2005	Ng
6,841,967 B2	1/2005	Kim et al.	6,939,358 B2	9/2005	Palacios et al.
6,843,403 B2	1/2005	Whitman	6,942,662 B2	9/2005	Goble et al.
6,843,789 B2	1/2005	Goble	6,942,674 B2	9/2005	Belef et al.
6,843,793 B2	1/2005	Brock et al.	6,945,444 B2	9/2005	Gresham et al.
6,846,307 B2	1/2005	Whitman et al.	6,945,981 B2	9/2005	Donofrio et al.
6,846,308 B2	1/2005	Whitman et al.	6,949,196 B2	9/2005	Schmitz et al.
6,846,309 B2	1/2005	Whitman et al.	6,951,562 B2	10/2005	Zwirnmann
6,847,190 B2	1/2005	Schaefer et al.	6,953,138 B1	10/2005	Dworak et al.
6,849,071 B2	2/2005	Whitman et al.	6,953,139 B2	10/2005	Milliman et al.
6,850,817 B1	2/2005	Green	6,953,461 B2	10/2005	McClurken et al.
6,852,122 B2	2/2005	Rush	6,957,758 B2	10/2005	Aranyi
6,852,330 B2	2/2005	Bowman et al.	6,958,035 B2	10/2005	Friedman et al.
6,853,879 B2	2/2005	Sunaoshi	D511,525 S	11/2005	Hernandez et al.
6,858,005 B2	2/2005	Ohline et al.	6,959,851 B2	11/2005	Heinrich
6,859,882 B2	2/2005	Fung	6,959,852 B2	11/2005	Shelton, IV et al.
RE38,708 E	3/2005	Bolanos et al.	6,960,107 B1	11/2005	Schaub et al.
D502,994 S	3/2005	Blake, III	6,960,163 B2	11/2005	Ewers et al.
6,861,142 B1	3/2005	Wilkie et al.	6,960,220 B2	11/2005	Marino et al.
6,861,954 B2	3/2005	Levin	6,962,587 B2	11/2005	Johnson et al.
6,863,668 B2	3/2005	Gillespie et al.	6,963,792 B1	11/2005	Green
6,863,694 B1	3/2005	Boyce et al.	6,964,363 B2	11/2005	Wales et al.
6,863,924 B2	3/2005	Ranganathan et al.	6,966,907 B2	11/2005	Goble
6,866,178 B2	3/2005	Adams et al.	6,966,909 B2	11/2005	Marshall et al.
6,866,668 B2	3/2005	Giannetti et al.	6,968,908 B2	11/2005	Tokunaga et al.
6,866,671 B2	3/2005	Tierney et al.	6,969,385 B2	11/2005	Moreyra
6,867,248 B1	3/2005	Martin et al.	6,969,395 B2	11/2005	Eskuri
6,869,430 B2	3/2005	Balbierz et al.	6,971,988 B2	12/2005	Orban, III
6,869,435 B2	3/2005	Blake, III	6,972,199 B2	12/2005	Leboutitz et al.
6,872,214 B2	3/2005	Sonnenschein et al.	6,974,435 B2	12/2005	Daw et al.
6,874,669 B2	4/2005	Adams et al.	6,974,462 B2	12/2005	Sater
6,876,850 B2	4/2005	Maeshima et al.	6,978,921 B2	12/2005	Shelton, IV et al.
6,877,647 B2	4/2005	Green et al.	6,978,922 B2	12/2005	Bilotti et al.
6,878,106 B1	4/2005	Herrmann	6,981,628 B2	1/2006	Wales
6,882,127 B2	4/2005	Konigbauer	6,981,941 B2	1/2006	Whitman et al.
6,883,199 B1	4/2005	Lundell et al.	6,981,978 B2	1/2006	Gannoe
6,884,392 B2	4/2005	Malkin et al.	6,984,203 B2	1/2006	Tartaglia et al.
			6,984,231 B2	1/2006	Goble et al.
			6,986,451 B1	1/2006	Mastri et al.
			6,988,649 B2	1/2006	Shelton, IV et al.
			6,988,650 B2	1/2006	Schwemberger et al.

(56)

References Cited

U.S. PATENT DOCUMENTS

6,989,034 B2	1/2006	Hammer et al.	7,063,712 B2	6/2006	Vargas et al.
6,990,731 B2	1/2006	Haytayan	7,064,509 B1	6/2006	Fu et al.
6,990,796 B2	1/2006	Schnipke et al.	7,066,879 B2	6/2006	Fowler et al.
6,991,146 B2	1/2006	Sinisi et al.	7,066,944 B2	6/2006	Laufer et al.
6,993,200 B2	1/2006	Tastl et al.	7,067,038 B2	6/2006	Trokhon et al.
6,993,413 B2	1/2006	Sunaoshi	7,070,083 B2	7/2006	Jankowski
6,994,708 B2	2/2006	Manzo	7,070,559 B2	7/2006	Adams et al.
6,995,729 B2	2/2006	Govari et al.	7,070,597 B2	7/2006	Truckai et al.
6,996,433 B2	2/2006	Burbank et al.	7,071,287 B2	7/2006	Rhine et al.
6,997,931 B2	2/2006	Sauer et al.	7,075,770 B1	7/2006	Smith
6,997,935 B2	2/2006	Anderson et al.	7,077,856 B2	7/2006	Whitman
6,998,736 B2	2/2006	Lee et al.	7,080,769 B2	7/2006	Vresh et al.
6,998,816 B2	2/2006	Wieck et al.	7,081,114 B2	7/2006	Rashidi
6,999,821 B2	2/2006	Jenney et al.	7,081,318 B2	7/2006	Lee et al.
7,000,818 B2	2/2006	Shelton, IV et al.	7,083,073 B2	8/2006	Yoshie et al.
7,000,819 B2	2/2006	Swayze et al.	7,083,075 B2	8/2006	Swayze et al.
7,000,911 B2	2/2006	McCormick et al.	7,083,571 B2	8/2006	Wang et al.
7,001,380 B2	2/2006	Goble	7,083,615 B2	8/2006	Peterson et al.
7,001,408 B2	2/2006	Knodel et al.	7,083,619 B2	8/2006	Truckai et al.
7,004,174 B2	2/2006	Eggers et al.	7,083,620 B2	8/2006	Jahns et al.
7,007,176 B2	2/2006	Goodfellow et al.	7,083,626 B2	8/2006	Hart et al.
7,008,433 B2	3/2006	Voellmicke et al.	7,086,267 B2	8/2006	Dworak et al.
7,008,435 B2	3/2006	Cummins	7,087,049 B2	8/2006	Nowlin et al.
7,009,039 B2	3/2006	Yayon et al.	7,087,054 B2	8/2006	Truckai et al.
7,011,213 B2	3/2006	Clark et al.	7,087,071 B2	8/2006	Nicholas et al.
7,011,657 B2	3/2006	Truckai et al.	7,090,637 B2	8/2006	Danitz et al.
7,014,640 B2	3/2006	Kemppainen et al.	7,090,673 B2	8/2006	Dycus et al.
7,018,357 B2	3/2006	Emmons	7,090,683 B2	8/2006	Brock et al.
7,018,390 B2	3/2006	Turovskiy et al.	7,090,684 B2	8/2006	McGuckin, Jr. et al.
7,021,399 B2	4/2006	Driessen	7,091,191 B2	8/2006	Laredo et al.
7,021,669 B1	4/2006	Lindermeir et al.	7,091,412 B2	8/2006	Wang et al.
7,022,131 B1	4/2006	Derowe et al.	7,093,492 B2	8/2006	Treiber et al.
7,023,159 B2	4/2006	Gorti et al.	7,094,202 B2	8/2006	Nobis et al.
7,025,064 B2	4/2006	Wang et al.	7,094,247 B2	8/2006	Monassevitch et al.
7,025,732 B2	4/2006	Thompson et al.	7,094,916 B2	8/2006	DeLuca et al.
7,025,743 B2	4/2006	Mann et al.	7,096,972 B2	8/2006	Orozco, Jr.
7,025,774 B2	4/2006	Freeman et al.	7,097,089 B2	8/2006	Marczyk
7,025,775 B2	4/2006	Gadberry et al.	7,097,644 B2	8/2006	Long
7,028,570 B2	4/2006	Ohta et al.	7,097,650 B2	8/2006	Weller et al.
7,029,435 B2	4/2006	Nakao	7,098,794 B2	8/2006	Lindsay et al.
7,029,439 B2	4/2006	Roberts et al.	7,100,949 B2	9/2006	Williams et al.
7,030,904 B2	4/2006	Adair et al.	7,101,187 B1	9/2006	Deconinck et al.
7,032,798 B2	4/2006	Whitman et al.	7,101,371 B2	9/2006	Dycus et al.
7,032,799 B2	4/2006	Viola et al.	7,101,394 B2	9/2006	Hamm et al.
7,033,356 B2	4/2006	Latterell et al.	7,104,741 B2	9/2006	Krohn
7,033,378 B2	4/2006	Smith et al.	7,108,695 B2	9/2006	Witt et al.
7,035,716 B2	4/2006	Harris et al.	7,108,701 B2	9/2006	Evens et al.
7,035,762 B2	4/2006	Menard et al.	7,108,709 B2	9/2006	Cummins
7,036,680 B1	5/2006	Flannery	7,111,768 B2	9/2006	Cummins et al.
7,037,314 B2	5/2006	Armstrong	7,111,769 B2	9/2006	Wales et al.
7,037,344 B2	5/2006	Kagan et al.	7,112,214 B2	9/2006	Peterson et al.
7,038,421 B2	5/2006	Trifilo	RE39,358 E	10/2006	Goble
7,041,088 B2	5/2006	Nawrocki et al.	D530,339 S	10/2006	Hernandez et al.
7,041,102 B2	5/2006	Truckai et al.	7,114,642 B2	10/2006	Whitman
7,041,868 B2	5/2006	Greene et al.	7,116,100 B1	10/2006	Mock et al.
7,043,852 B2	5/2006	Hayashida et al.	7,118,020 B2	10/2006	Lee et al.
7,044,350 B2	5/2006	Kameyama et al.	7,118,528 B1	10/2006	Piskun
7,044,352 B2	5/2006	Shelton, IV et al.	7,118,563 B2	10/2006	Weckwerth et al.
7,044,353 B2	5/2006	Mastri et al.	7,118,582 B1	10/2006	Wang et al.
7,046,082 B2	5/2006	Komiya et al.	7,119,534 B2	10/2006	Butzmann
7,048,165 B2	5/2006	Haramiishi	7,121,446 B2	10/2006	Arad et al.
7,048,687 B1	5/2006	Reuss et al.	7,121,773 B2	10/2006	Mikiya et al.
7,048,716 B1	5/2006	Kucharczyk et al.	7,122,028 B2	10/2006	Looper et al.
7,048,745 B2	5/2006	Tierney et al.	7,125,403 B2	10/2006	Julian et al.
7,052,454 B2	5/2006	Taylor	7,125,409 B2	10/2006	Truckai et al.
7,052,494 B2	5/2006	Goble et al.	7,126,303 B2	10/2006	Farritor et al.
7,052,499 B2	5/2006	Steger et al.	7,126,879 B2	10/2006	Snyder
7,055,730 B2	6/2006	Ehrenfels et al.	7,128,253 B2	10/2006	Mastri et al.
7,055,731 B2	6/2006	Shelton, IV et al.	7,128,254 B2	10/2006	Shelton, IV et al.
7,056,123 B2	6/2006	Gregorio et al.	7,128,748 B2	10/2006	Mooradian et al.
7,056,284 B2	6/2006	Martone et al.	7,131,445 B2	11/2006	Amoah
7,056,330 B2	6/2006	Gayton	7,133,601 B2	11/2006	Phillips et al.
7,059,331 B2	6/2006	Adams et al.	7,134,364 B2	11/2006	Kageler et al.
7,059,508 B2	6/2006	Shelton, IV et al.	7,134,587 B2	11/2006	Schwemberger et al.
7,063,671 B2	6/2006	Couvillon, Jr.	7,135,027 B2	11/2006	Delmotte
			7,137,980 B2	11/2006	Buysse et al.
			7,137,981 B2	11/2006	Long
			7,139,016 B2	11/2006	Squilla et al.
			7,140,527 B2	11/2006	Ehrenfels et al.

(56)

References Cited

U.S. PATENT DOCUMENTS

7,140,528 B2	11/2006	Shelton, IV	7,225,959 B2	6/2007	Patton et al.
7,141,055 B2	11/2006	Abrams et al.	7,225,963 B2	6/2007	Scirica
7,143,923 B2	12/2006	Shelton, IV et al.	7,225,964 B2	6/2007	Mastri et al.
7,143,924 B2	12/2006	Scirica et al.	7,226,450 B2	6/2007	Athanasίου et al.
7,143,925 B2	12/2006	Shelton, IV et al.	7,226,467 B2	6/2007	Lucatero et al.
7,143,926 B2	12/2006	Shelton, IV et al.	7,228,505 B2	6/2007	Shimazu et al.
7,146,191 B2	12/2006	Kerner et al.	7,229,408 B2	6/2007	Douglas et al.
7,147,138 B2	12/2006	Shelton, IV	7,234,624 B2	6/2007	Gresham et al.
7,147,139 B2	12/2006	Schwemberger et al.	7,235,072 B2	6/2007	Sartor et al.
7,147,140 B2	12/2006	Wukusick et al.	7,235,089 B1	6/2007	McGuckin, Jr.
7,147,637 B2	12/2006	Goble	7,235,302 B2	6/2007	Jing et al.
7,147,648 B2	12/2006	Lin	7,237,708 B1	7/2007	Guy et al.
7,147,650 B2	12/2006	Lee	7,238,195 B2	7/2007	Viola
7,150,748 B2	12/2006	Ebbutt et al.	7,238,901 B2	7/2007	Kim et al.
7,153,300 B2	12/2006	Goble	7,239,657 B1	7/2007	Gunnarsson
7,153,314 B2	12/2006	Laufer et al.	7,241,288 B2	7/2007	Braun
7,155,316 B2	12/2006	Sutherland et al.	7,241,289 B2	7/2007	Braun
7,156,863 B2	1/2007	Sonnenschein et al.	7,246,734 B2	7/2007	Shelton, IV
7,159,750 B2	1/2007	Racenet et al.	7,247,161 B2	7/2007	Johnston et al.
7,160,296 B2	1/2007	Pearson et al.	7,249,267 B2	7/2007	Chapuis
7,160,299 B2	1/2007	Baily	7,252,641 B2	8/2007	Thompson et al.
7,160,311 B2	1/2007	Blatter et al.	7,252,660 B2	8/2007	Kunz
7,161,036 B2	1/2007	Oikawa et al.	7,255,012 B2	8/2007	Hedtke
7,161,580 B2	1/2007	Bailey et al.	7,255,696 B2	8/2007	Goble et al.
7,162,758 B2	1/2007	Skinner	7,256,695 B2	8/2007	Hamel et al.
7,163,563 B2	1/2007	Schwartz et al.	7,258,262 B2	8/2007	Mastri et al.
7,166,117 B2	1/2007	Hellenkamp	7,258,546 B2	8/2007	Beier et al.
7,166,133 B2	1/2007	Evans et al.	7,260,431 B2	8/2007	Libbus et al.
7,168,604 B2	1/2007	Milliman et al.	7,265,374 B2	9/2007	Lee et al.
7,170,910 B2	1/2007	Chen et al.	7,267,677 B2	9/2007	Johnson et al.
7,171,279 B2	1/2007	Buckingham et al.	7,267,679 B2	9/2007	McGuckin, Jr. et al.
7,172,104 B2	2/2007	Scirica et al.	7,272,002 B2	9/2007	Drapeau
7,172,593 B2	2/2007	Trieu et al.	7,273,483 B2	9/2007	Wiener et al.
7,172,615 B2	2/2007	Morriss et al.	7,273,488 B2	9/2007	Nakamura et al.
7,174,202 B2	2/2007	Bladen et al.	D552,623 S	10/2007	Vong et al.
7,174,636 B2	2/2007	Lowe	7,275,674 B2	10/2007	Racenet et al.
7,177,533 B2	2/2007	McFarlin et al.	7,276,044 B2	10/2007	Ferry et al.
7,179,223 B2	2/2007	Motoki et al.	7,276,068 B2	10/2007	Johnson et al.
7,179,267 B2	2/2007	Nolan et al.	7,278,562 B2	10/2007	Mastri et al.
7,182,239 B1	2/2007	Myers	7,278,563 B1	10/2007	Green
7,182,763 B2	2/2007	Nardella	7,278,949 B2	10/2007	Bader
7,183,737 B2	2/2007	Kitagawa	7,278,994 B2	10/2007	Goble
7,187,960 B2	3/2007	Abreu	7,282,048 B2	10/2007	Goble et al.
7,188,758 B2	3/2007	Viola et al.	7,283,096 B2	10/2007	Geisheimer et al.
7,189,207 B2	3/2007	Viola	7,286,850 B2	10/2007	Frielink et al.
7,190,147 B2	3/2007	Gileff et al.	7,287,682 B1	10/2007	Ezzat et al.
7,193,199 B2	3/2007	Jang	7,289,139 B2	10/2007	Amling et al.
7,195,627 B2	3/2007	Amoah et al.	7,293,685 B2	11/2007	Ehrenfels et al.
7,196,911 B2	3/2007	Takano et al.	7,295,893 B2	11/2007	Sunaoshi
D541,418 S	4/2007	Schechter et al.	7,295,907 B2	11/2007	Lu et al.
7,197,965 B1	4/2007	Anderson	7,296,722 B2	11/2007	Ivanko
7,199,537 B2	4/2007	Okamura et al.	7,296,724 B2	11/2007	Green et al.
7,199,545 B2	4/2007	Oleynikov et al.	7,297,149 B2	11/2007	Vitali et al.
7,202,576 B1	4/2007	Dechene et al.	7,300,373 B2	11/2007	Jinno et al.
7,202,653 B2	4/2007	Pai	7,300,431 B2	11/2007	Dubrovsky
7,204,404 B2	4/2007	Nguyen et al.	7,300,450 B2	11/2007	Vleugels et al.
7,204,835 B2	4/2007	Latterell et al.	7,303,106 B2	12/2007	Milliman et al.
7,205,959 B2	4/2007	Henriksson	7,303,107 B2	12/2007	Milliman et al.
7,206,626 B2	4/2007	Quaid, III	7,303,108 B2	12/2007	Shelton, IV
7,207,233 B2	4/2007	Wadge	7,303,502 B2	12/2007	Thompson
7,207,471 B2	4/2007	Heinrich et al.	7,303,556 B2	12/2007	Metzger
7,207,472 B2	4/2007	Wukusick et al.	7,306,597 B2	12/2007	Manzo
7,207,556 B2	4/2007	Saitoh et al.	7,308,998 B2	12/2007	Mastri et al.
7,208,005 B2	4/2007	Frecker et al.	7,311,238 B2	12/2007	Liu
7,210,609 B2	5/2007	Leiboff et al.	7,313,430 B2	12/2007	Urquhart et al.
7,211,081 B2	5/2007	Goble	7,314,473 B2	1/2008	Jinno et al.
7,211,084 B2	5/2007	Goble et al.	7,320,704 B2	1/2008	Lashinski et al.
7,211,092 B2	5/2007	Hughett	7,322,859 B2	1/2008	Evans
7,211,979 B2	5/2007	Khatib et al.	7,322,975 B2	1/2008	Goble et al.
7,213,736 B2	5/2007	Wales et al.	7,322,994 B2	1/2008	Nicholas et al.
7,214,224 B2	5/2007	Goble	7,324,572 B2	1/2008	Chang
7,215,517 B2	5/2007	Takamatsu	7,326,203 B2	2/2008	Papineau et al.
7,217,285 B2	5/2007	Vargas et al.	7,326,213 B2	2/2008	Benderev et al.
7,220,260 B2	5/2007	Fleming et al.	7,328,828 B2	2/2008	Ortiz et al.
7,220,272 B2	5/2007	Weadock	7,328,829 B2	2/2008	Arad et al.
			7,330,004 B2	2/2008	DeJonge et al.
			7,331,340 B2	2/2008	Barney
			7,331,343 B2	2/2008	Schmidt et al.
			7,331,403 B2	2/2008	Berry et al.

(56)

References Cited

U.S. PATENT DOCUMENTS

7,331,406 B2	2/2008	Wottreng, Jr. et al.	7,408,310 B2	8/2008	Hong et al.
7,331,969 B1	2/2008	Ingnas et al.	7,410,085 B2	8/2008	Wolf et al.
7,334,717 B2	2/2008	Rethy et al.	7,410,086 B2	8/2008	Ortiz et al.
7,334,718 B2	2/2008	McAlister et al.	7,410,483 B2	8/2008	Danitz et al.
7,335,199 B2	2/2008	Goble et al.	7,413,563 B2	8/2008	Corcoran et al.
7,335,401 B2	2/2008	Finke et al.	7,416,101 B2	8/2008	Shelton, IV et al.
7,336,045 B2	2/2008	Clermonts	7,418,078 B2	8/2008	Blanz et al.
7,336,048 B2	2/2008	Lohr	RE40,514 E	9/2008	Mastri et al.
7,336,183 B2	2/2008	Reddy et al.	7,419,080 B2	9/2008	Smith et al.
7,336,184 B2	2/2008	Smith et al.	7,419,081 B2	9/2008	Ehrenfels et al.
7,337,774 B2	3/2008	Webb	7,419,321 B2	9/2008	Tereschouk
7,338,505 B2	3/2008	Belson	7,419,495 B2	9/2008	Menn et al.
7,338,513 B2	3/2008	Lee et al.	7,422,136 B1	9/2008	Marczyk
7,341,554 B2	3/2008	Sekine et al.	7,422,138 B2	9/2008	Bilotti et al.
7,341,555 B2	3/2008	Ootawara et al.	7,422,139 B2	9/2008	Shelton, IV et al.
7,341,591 B2	3/2008	Grinberg	7,424,965 B2	9/2008	Racenet et al.
7,343,920 B2	3/2008	Toby et al.	7,427,607 B2	9/2008	Suzuki
7,344,532 B2	3/2008	Goble et al.	D578,644 S	10/2008	Shumer et al.
7,344,533 B2	3/2008	Pearson et al.	7,430,772 B2	10/2008	Van Es
7,346,344 B2	3/2008	Fontaine	7,431,188 B1	10/2008	Marczyk
7,346,406 B2	3/2008	Brotto et al.	7,431,189 B2	10/2008	Shelton, IV et al.
7,348,763 B1	3/2008	Reinhart et al.	7,431,230 B2	10/2008	McPherson et al.
7,348,875 B2	3/2008	Hughes et al.	7,431,694 B2	10/2008	Stefanchik et al.
RE40,237 E	4/2008	Bilotti et al.	7,431,730 B2	10/2008	Viola
7,351,258 B2	4/2008	Ricotta et al.	7,434,715 B2	10/2008	Shelton, IV et al.
7,354,398 B2	4/2008	Kanazawa	7,434,717 B2	10/2008	Shelton, IV et al.
7,354,447 B2	4/2008	Shelton, IV et al.	7,435,249 B2	10/2008	Buysse et al.
7,354,502 B2	4/2008	Polat et al.	7,438,209 B1	10/2008	Hess et al.
7,357,287 B2	4/2008	Shelton, IV et al.	7,438,718 B2	10/2008	Milliman et al.
7,357,806 B2	4/2008	Rivera et al.	7,439,354 B2	10/2008	Lenges et al.
7,361,168 B2	4/2008	Makower et al.	7,441,684 B2	10/2008	Shelton, IV et al.
7,361,195 B2	4/2008	Schwartz et al.	7,441,685 B1	10/2008	Boudreaux
7,362,062 B2	4/2008	Schneider et al.	7,442,201 B2	10/2008	Pugsley et al.
7,364,060 B2	4/2008	Milliman	7,443,547 B2	10/2008	Moreno et al.
7,364,061 B2	4/2008	Swayze et al.	7,446,131 B1	11/2008	Liu et al.
7,367,485 B2	5/2008	Shelton, IV et al.	7,448,525 B2	11/2008	Shelton, IV et al.
7,367,973 B2	5/2008	Manzo et al.	7,450,010 B1	11/2008	Gravelle et al.
7,368,124 B2	5/2008	Chun et al.	7,450,991 B2	11/2008	Smith et al.
7,371,210 B2	5/2008	Brock et al.	7,451,904 B2	11/2008	Shelton, IV
7,371,403 B2	5/2008	McCarthy et al.	7,455,208 B2	11/2008	Wales et al.
7,375,493 B2	5/2008	Calhoon et al.	7,455,676 B2	11/2008	Holsten et al.
7,377,918 B2	5/2008	Amoah	7,455,682 B2	11/2008	Viola
7,377,928 B2	5/2008	Zubik et al.	7,455,687 B2	11/2008	Saunders et al.
7,378,817 B2	5/2008	Calhoon et al.	D582,934 S	12/2008	Byeon
RE40,388 E	6/2008	Gines	7,461,767 B2	12/2008	Viola et al.
D570,868 S	6/2008	Hosokawa et al.	7,462,187 B2	12/2008	Johnston et al.
7,380,695 B2	6/2008	Doll et al.	7,464,845 B2	12/2008	Chou
7,380,696 B2	6/2008	Shelton, IV et al.	7,464,846 B2	12/2008	Shelton, IV et al.
7,384,403 B2	6/2008	Sherman	7,464,847 B2	12/2008	Viola et al.
7,384,417 B2	6/2008	Cucin	7,464,848 B2	12/2008	Green et al.
7,386,365 B2	6/2008	Nixon	7,464,849 B2	12/2008	Shelton, IV et al.
7,386,730 B2	6/2008	Uchikubo	7,467,740 B2	12/2008	Shelton, IV et al.
7,388,217 B2	6/2008	Buschbeck et al.	7,467,849 B2	12/2008	Silverbrook et al.
7,388,484 B2	6/2008	Hsu	7,472,814 B2	1/2009	Mastri et al.
7,391,173 B2	6/2008	Schena	7,472,815 B2	1/2009	Shelton, IV et al.
7,394,190 B2	7/2008	Huang	7,472,816 B2	1/2009	Holsten et al.
7,396,356 B2	7/2008	Mollenauer	7,473,221 B2	1/2009	Ewers et al.
7,397,364 B2	7/2008	Govari	7,473,253 B2	1/2009	Dycus et al.
7,398,707 B2	7/2008	Morley et al.	7,473,263 B2	1/2009	Johnston et al.
7,398,907 B2	7/2008	Racenet et al.	7,476,237 B2	1/2009	Taniguchi et al.
7,398,908 B2	7/2008	Holsten et al.	7,479,147 B2	1/2009	Honeycutt et al.
7,400,107 B2	7/2008	Schneider et al.	7,479,608 B2	1/2009	Smith
7,400,752 B2	7/2008	Zacharias	7,481,347 B2	1/2009	Roy
7,401,000 B2	7/2008	Nakamura	7,481,348 B2	1/2009	Marczyk
7,401,721 B2	7/2008	Holsten et al.	7,481,349 B2	1/2009	Holsten et al.
7,404,449 B2	7/2008	Birmingham et al.	7,481,824 B2	1/2009	Boudreaux et al.
7,404,508 B2	7/2008	Smith et al.	7,485,124 B2	2/2009	Kuhns et al.
7,404,509 B2	7/2008	Ortiz et al.	7,485,133 B2	2/2009	Cannon et al.
7,404,822 B2	7/2008	Viart et al.	7,485,142 B2	2/2009	Milo
D575,793 S	8/2008	Ording	7,487,899 B2	2/2009	Shelton, IV et al.
7,407,074 B2	8/2008	Ortiz et al.	7,489,055 B2	2/2009	Jeong et al.
7,407,075 B2	8/2008	Holsten et al.	7,490,749 B2	2/2009	Schall et al.
7,407,076 B2	8/2008	Racenet et al.	7,491,232 B2	2/2009	Bolduc et al.
7,407,077 B2	8/2008	Ortiz et al.	7,492,261 B2	2/2009	Cambre et al.
7,407,078 B2	8/2008	Shelton, IV et al.	7,494,039 B2	2/2009	Racenet et al.
			7,494,460 B2	2/2009	Haarstad et al.
			7,494,499 B2	2/2009	Nagase et al.
			7,494,501 B2	2/2009	Ahlberg et al.
			7,497,137 B2	3/2009	Tellenbach et al.

(56)

References Cited

U.S. PATENT DOCUMENTS

7,500,979 B2	3/2009	Hueil et al.	7,604,668 B2	10/2009	Farnsworth et al.
7,501,198 B2	3/2009	Barlev et al.	7,605,826 B2	10/2009	Sauer
7,503,474 B2	3/2009	Hillstead et al.	7,607,557 B2	10/2009	Shelton, IV et al.
7,506,790 B2	3/2009	Shelton, IV	7,608,091 B2	10/2009	Goldfarb et al.
7,506,791 B2	3/2009	Omaits et al.	D604,325 S	11/2009	Ebeling et al.
7,507,202 B2	3/2009	Schoellhorn	7,611,038 B2	11/2009	Racenet et al.
7,510,107 B2	3/2009	Timm et al.	7,611,474 B2	11/2009	Hibner et al.
7,510,534 B2	3/2009	Burdorff et al.	7,615,003 B2	11/2009	Stefanchik et al.
7,510,566 B2	3/2009	Jacobs et al.	7,615,006 B2	11/2009	Abe
7,513,407 B1	4/2009	Chang	7,615,067 B2	11/2009	Lee et al.
7,513,408 B2	4/2009	Shelton, IV et al.	7,617,961 B2	11/2009	Viola
7,517,356 B2	4/2009	Heinrich	7,618,427 B2	11/2009	Ortiz et al.
7,524,320 B2	4/2009	Tierney et al.	D605,201 S	12/2009	Lorenz et al.
7,527,632 B2	5/2009	Houghton et al.	D606,992 S	12/2009	Liu et al.
7,530,984 B2	5/2009	Sonnenschein et al.	D607,010 S	12/2009	Kocmick
7,530,985 B2	5/2009	Takemoto et al.	7,624,902 B2	12/2009	Marczyk et al.
7,533,906 B2	5/2009	Luetgen et al.	7,624,903 B2	12/2009	Green et al.
7,534,259 B2	5/2009	Lashinski et al.	7,625,370 B2	12/2009	Hart et al.
7,540,867 B2	6/2009	Jinno et al.	7,625,388 B2	12/2009	Boukhny et al.
7,540,872 B2	6/2009	Schechter et al.	7,625,662 B2	12/2009	Vaisnys et al.
7,542,807 B2	6/2009	Bertolero et al.	7,630,841 B2	12/2009	Comisky et al.
7,543,730 B1	6/2009	Marczyk	7,631,793 B2	12/2009	Rethy et al.
7,544,197 B2	6/2009	Kelsch et al.	7,631,794 B2	12/2009	Rethy et al.
7,546,939 B2	6/2009	Adams et al.	7,635,074 B2	12/2009	Olson et al.
7,546,940 B2	6/2009	Milliman et al.	7,635,922 B2	12/2009	Becker
7,547,287 B2	6/2009	Boecker et al.	7,637,409 B2	12/2009	Marczyk
7,547,312 B2	6/2009	Bauman et al.	7,637,410 B2	12/2009	Marczyk
7,549,563 B2	6/2009	Mather et al.	7,638,958 B2	12/2009	Philipp et al.
7,549,564 B2	6/2009	Boudreaux	7,641,091 B2	1/2010	Olson et al.
7,549,998 B2	6/2009	Braun	7,641,092 B2	1/2010	Kruszynski et al.
7,552,854 B2	6/2009	Wixey et al.	7,641,093 B2	1/2010	Doll et al.
7,553,173 B2	6/2009	Kowalick	7,641,095 B2	1/2010	Viola
7,553,275 B2	6/2009	Padget et al.	7,641,671 B2	1/2010	Crainich
7,554,343 B2	6/2009	Bromfield	7,644,783 B2	1/2010	Roberts et al.
7,556,185 B2	7/2009	Viola	7,644,848 B2	1/2010	Swayze et al.
7,556,186 B2	7/2009	Milliman	7,645,230 B2	1/2010	Mikkaichi et al.
7,556,647 B2	7/2009	Drews et al.	7,648,055 B2	1/2010	Marczyk
7,559,449 B2	7/2009	Viola	7,648,457 B2	1/2010	Stefanchik et al.
7,559,450 B2	7/2009	Wales et al.	7,648,519 B2	1/2010	Lee et al.
7,559,452 B2	7/2009	Wales et al.	7,650,185 B2	1/2010	Maile et al.
7,559,937 B2	7/2009	de la Torre et al.	7,651,017 B2	1/2010	Ortiz et al.
7,561,637 B2	7/2009	Jonsson et al.	7,651,498 B2	1/2010	Shifrin et al.
7,562,910 B2	7/2009	Kertesz et al.	7,654,431 B2	2/2010	Hueil et al.
7,563,269 B2	7/2009	Hashiguchi	7,655,003 B2	2/2010	Lorang et al.
7,563,862 B2	7/2009	Sieg et al.	7,655,004 B2	2/2010	Long
7,565,993 B2	7/2009	Milliman et al.	7,655,288 B2	2/2010	Bauman et al.
7,566,300 B2	7/2009	Devierre et al.	7,655,584 B2	2/2010	Biran et al.
7,567,045 B2	7/2009	Fristedt	7,656,131 B2	2/2010	Embrey et al.
7,568,603 B2	8/2009	Shelton, IV et al.	7,658,311 B2	2/2010	Boudreaux
7,568,604 B2	8/2009	Ehrenfels et al.	7,658,312 B2	2/2010	Vidal et al.
7,568,619 B2	8/2009	Todd et al.	7,658,705 B2	2/2010	Melvin et al.
7,572,285 B2	8/2009	Frey et al.	7,659,219 B2	2/2010	Biran et al.
7,575,144 B2	8/2009	Ortiz et al.	7,661,448 B2	2/2010	Kim et al.
7,578,825 B2	8/2009	Huebner	7,662,161 B2	2/2010	Briganti et al.
D600,712 S	9/2009	LaManna et al.	7,665,646 B2	2/2010	Prommersberger
7,583,063 B2	9/2009	Dooley	7,665,647 B2	2/2010	Shelton, IV et al.
7,584,880 B2	9/2009	Racenet et al.	7,666,195 B2	2/2010	Kelleher et al.
7,586,289 B2	9/2009	Andruk et al.	7,669,746 B2	3/2010	Shelton, IV
7,588,174 B2	9/2009	Holsten et al.	7,669,747 B2	3/2010	Weisenburgh, II et al.
7,588,175 B2	9/2009	Timm et al.	7,670,334 B2	3/2010	Hueil et al.
7,588,176 B2	9/2009	Timm et al.	7,670,337 B2	3/2010	Young
7,588,177 B2	9/2009	Racenet	7,673,780 B2	3/2010	Shelton, IV et al.
7,591,783 B2	9/2009	Boulais et al.	7,673,781 B2	3/2010	Swayze et al.
7,591,818 B2	9/2009	Bertolero et al.	7,673,782 B2	3/2010	Hess et al.
7,593,766 B2	9/2009	Faber et al.	7,673,783 B2	3/2010	Morgan et al.
7,595,642 B2	9/2009	Doyle	7,674,253 B2	3/2010	Fisher et al.
7,597,229 B2	10/2009	Boudreaux et al.	7,674,255 B2	3/2010	Braun
7,597,230 B2	10/2009	Racenet et al.	7,674,263 B2	3/2010	Ryan
7,597,693 B2	10/2009	Garrison	7,674,270 B2	3/2010	Layer
7,597,699 B2	10/2009	Rogers	7,678,121 B1	3/2010	Knodel
7,598,972 B2	10/2009	Tomita	7,682,307 B2	3/2010	Danitz et al.
7,600,663 B2	10/2009	Green	7,682,367 B2	3/2010	Shah et al.
7,604,118 B2	10/2009	Iio et al.	7,682,686 B2	3/2010	Curro et al.
7,604,150 B2	10/2009	Boudreaux	7,686,201 B2	3/2010	Csiky
7,604,151 B2	10/2009	Hess et al.	7,686,804 B2	3/2010	Johnson et al.
			7,686,826 B2	3/2010	Lee et al.
			7,688,028 B2	3/2010	Phillips et al.
			7,690,547 B2	4/2010	Racenet et al.
			7,691,098 B2	4/2010	Wallace et al.

(56)

References Cited

U.S. PATENT DOCUMENTS

7,691,103 B2	4/2010	Fernandez et al.	7,753,246 B2	7/2010	Scirica
7,691,106 B2	4/2010	Schenberger et al.	7,753,904 B2	7/2010	Shelton, IV et al.
7,694,864 B2	4/2010	Okada et al.	7,757,924 B2	7/2010	Gerbi et al.
7,694,865 B2	4/2010	Scirica	7,758,594 B2	7/2010	Lamson et al.
7,695,485 B2	4/2010	Whitman et al.	7,758,612 B2	7/2010	Shipp
7,695,493 B2	4/2010	Saadat et al.	7,758,613 B2	7/2010	Whitman
7,699,204 B2	4/2010	Viola	7,762,462 B2	7/2010	Gelbman
7,699,835 B2	4/2010	Lee et al.	7,762,998 B2	7/2010	Birk et al.
7,699,844 B2	4/2010	Utley et al.	D622,286 S	8/2010	Umezawa
7,699,846 B2	4/2010	Ryan	7,766,207 B2	8/2010	Mather et al.
7,699,856 B2	4/2010	Van Wyk et al.	7,766,209 B2	8/2010	Baxter, III et al.
7,699,859 B2	4/2010	Bombard et al.	7,766,210 B2	8/2010	Shelton, IV et al.
7,699,860 B2	4/2010	Huitema et al.	7,766,821 B2	8/2010	Brunnen et al.
7,699,868 B2	4/2010	Frank et al.	7,766,894 B2	8/2010	Weitzner et al.
7,703,653 B2	4/2010	Shah et al.	7,770,658 B2	8/2010	Ito et al.
7,705,559 B2	4/2010	Powell et al.	7,770,773 B2	8/2010	Whitman et al.
7,706,853 B2	4/2010	Hacker et al.	7,770,774 B2	8/2010	Mastri et al.
7,708,180 B2	5/2010	Murray et al.	7,770,775 B2	8/2010	Shelton, IV et al.
7,708,181 B2	5/2010	Cole et al.	7,770,776 B2	8/2010	Chen et al.
7,708,182 B2	5/2010	Viola	7,771,396 B2	8/2010	Stefanchik et al.
7,708,758 B2	5/2010	Lee et al.	7,772,720 B2	8/2010	McGee et al.
7,708,768 B2	5/2010	Danek et al.	7,772,725 B2	8/2010	Siman-Tov
7,709,136 B2	5/2010	Touchton et al.	7,775,972 B2	8/2010	Brock et al.
7,712,182 B2	5/2010	Zeiler et al.	7,776,037 B2	8/2010	Odom
7,713,190 B2	5/2010	Brock et al.	7,776,060 B2	8/2010	Mooradian et al.
7,713,542 B2	5/2010	Xu et al.	7,776,065 B2	8/2010	Griffiths et al.
7,714,239 B2	5/2010	Smith	7,778,004 B2	8/2010	Nerheim et al.
7,714,334 B2	5/2010	Lin	7,779,614 B1	8/2010	McGonagle et al.
7,717,312 B2	5/2010	Beetel	7,779,737 B2	8/2010	Newman, Jr. et al.
7,717,313 B2	5/2010	Criscuolo et al.	7,780,054 B2	8/2010	Wales
7,717,846 B2	5/2010	Zirps et al.	7,780,055 B2	8/2010	Scirica et al.
7,717,873 B2	5/2010	Swick	7,780,309 B2	8/2010	McMillan et al.
7,717,915 B2	5/2010	Miyazawa	7,780,651 B2	8/2010	Madhani et al.
7,717,926 B2	5/2010	Whitfield et al.	7,780,663 B2	8/2010	Yates et al.
7,718,180 B2	5/2010	Karp	7,780,685 B2	8/2010	Hunt et al.
7,718,556 B2	5/2010	Matsuda et al.	7,782,382 B2	8/2010	Fujimura
7,721,930 B2	5/2010	McKenna et al.	7,784,662 B2	8/2010	Wales et al.
7,721,931 B2	5/2010	Shelton, IV et al.	7,784,663 B2	8/2010	Shelton, IV
7,721,932 B2	5/2010	Cole et al.	7,787,256 B2	8/2010	Chan et al.
7,721,933 B2	5/2010	Ehrenfels et al.	7,789,283 B2	9/2010	Shah
7,721,934 B2	5/2010	Shelton, IV et al.	7,789,875 B2	9/2010	Brock et al.
7,721,936 B2	5/2010	Shalton, IV et al.	7,789,883 B2	9/2010	Takashino et al.
7,722,527 B2	5/2010	Bouchier et al.	7,789,889 B2	9/2010	Zubik et al.
7,722,607 B2	5/2010	Dumbauld et al.	7,793,812 B2	9/2010	Moore et al.
7,722,610 B2	5/2010	Viola et al.	7,794,475 B2	9/2010	Hess et al.
7,725,214 B2	5/2010	Diolaiti	7,798,386 B2	9/2010	Schall et al.
7,726,171 B2	6/2010	Langlotz et al.	7,799,039 B2	9/2010	Shelton, IV et al.
7,726,537 B2	6/2010	Olson et al.	7,799,044 B2	9/2010	Johnston et al.
7,726,538 B2	6/2010	Holsten et al.	7,799,965 B2	9/2010	Patel et al.
7,726,539 B2	6/2010	Holsten et al.	7,803,151 B2	9/2010	Whitman
7,727,954 B2	6/2010	McKay	7,806,871 B2	10/2010	Li et al.
7,728,553 B2	6/2010	Carrier et al.	7,806,891 B2	10/2010	Nowlin et al.
7,729,742 B2	6/2010	Govari	7,810,690 B2	10/2010	Bilotti et al.
7,731,072 B2	6/2010	Timm et al.	7,810,691 B2	10/2010	Boyden et al.
7,731,073 B2	6/2010	Wixey et al.	7,810,692 B2	10/2010	Hall et al.
7,731,724 B2	6/2010	Huitema et al.	7,810,693 B2	10/2010	Broehl et al.
7,735,703 B2	6/2010	Morgan et al.	7,811,275 B2	10/2010	Birk et al.
7,735,704 B2	6/2010	Bilotti	7,814,816 B2	10/2010	Alberti et al.
7,736,254 B2	6/2010	Schena	7,815,092 B2	10/2010	Whitman et al.
7,736,306 B2	6/2010	Brustad et al.	7,815,565 B2	10/2010	Stefanchik et al.
7,736,374 B2	6/2010	Vaughan et al.	7,815,662 B2	10/2010	Spivey et al.
7,738,971 B2	6/2010	Swayze et al.	7,819,296 B2	10/2010	Hueil et al.
7,740,159 B2	6/2010	Shelton, IV et al.	7,819,297 B2	10/2010	Doll et al.
7,742,036 B2	6/2010	Grant et al.	7,819,298 B2	10/2010	Hall et al.
7,743,960 B2	6/2010	Whitman et al.	7,819,299 B2	10/2010	Shelton, IV et al.
7,744,624 B2	6/2010	Bettuchi	7,819,799 B2	10/2010	Merril et al.
7,744,627 B2	6/2010	Orban, III et al.	7,819,884 B2	10/2010	Lee et al.
7,744,628 B2	6/2010	Viola	7,819,885 B2	10/2010	Cooper
7,747,146 B2	6/2010	Milano et al.	7,819,886 B2	10/2010	Whitfield et al.
7,748,587 B2	7/2010	Haramiishi et al.	7,819,894 B2	10/2010	Mitsuishi et al.
7,748,632 B2	7/2010	Coleman et al.	7,823,592 B2	11/2010	Bettuchi et al.
7,749,204 B2	7/2010	Dhanaraj et al.	7,823,760 B2	11/2010	Zemlok et al.
7,749,240 B2	7/2010	Takahashi et al.	7,824,401 B2	11/2010	Manzo et al.
7,751,870 B2	7/2010	Whitman	7,824,422 B2	11/2010	Benchetrit
7,753,245 B2	7/2010	Boudreaux et al.	7,824,426 B2	11/2010	Racenet et al.
			7,828,189 B2	11/2010	Holsten et al.
			7,828,794 B2	11/2010	Sartor
			7,828,808 B2	11/2010	Hinman et al.
			7,829,416 B2	11/2010	Kudou et al.

(56)

References Cited

U.S. PATENT DOCUMENTS

7,831,292 B2	11/2010	Quaid et al.	7,896,877 B2	3/2011	Hall et al.
7,832,408 B2	11/2010	Shelton, IV et al.	7,896,895 B2	3/2011	Boudreaux et al.
7,832,611 B2	11/2010	Boyden et al.	7,896,897 B2	3/2011	Gresham et al.
7,832,612 B2	11/2010	Baxter, III et al.	7,896,900 B2	3/2011	Frank et al.
7,833,234 B2	11/2010	Bailly et al.	7,898,198 B2	3/2011	Murphree
7,835,823 B2	11/2010	Sillman et al.	7,900,805 B2	3/2011	Shelton, IV et al.
7,836,400 B2	11/2010	May et al.	7,900,806 B2	3/2011	Chen et al.
7,837,079 B2	11/2010	Holsten et al.	7,901,381 B2	3/2011	Birk et al.
7,837,080 B2	11/2010	Schwemberger	7,905,380 B2	3/2011	Shelton, IV et al.
7,837,081 B2	11/2010	Holsten et al.	7,905,381 B2	3/2011	Baxter, III et al.
7,837,425 B2	11/2010	Saeki et al.	7,905,881 B2	3/2011	Masuda et al.
7,837,685 B2	11/2010	Weinberg et al.	7,905,889 B2	3/2011	Catanese, III et al.
7,837,687 B2	11/2010	Harp	7,905,890 B2	3/2011	Whitfield et al.
7,837,694 B2	11/2010	Tethrake et al.	7,905,902 B2	3/2011	Huitema et al.
7,838,789 B2	11/2010	Stoffers et al.	7,909,039 B2	3/2011	Hur
7,839,109 B2	11/2010	Carmen, Jr. et al.	7,909,191 B2	3/2011	Baker et al.
7,840,253 B2	11/2010	Tremblay et al.	7,909,220 B2	3/2011	Viola
7,841,503 B2	11/2010	Sonnenschein et al.	7,909,221 B2	3/2011	Viola et al.
7,842,025 B2	11/2010	Coleman et al.	7,909,224 B2	3/2011	Prommersberger
7,842,028 B2	11/2010	Lee	7,913,891 B2	3/2011	Doll et al.
7,843,158 B2	11/2010	Prisco	7,913,893 B2	3/2011	Mastri et al.
7,845,533 B2	12/2010	Marczyk et al.	7,914,521 B2	3/2011	Wang et al.
7,845,534 B2	12/2010	Viola et al.	7,914,543 B2	3/2011	Roth et al.
7,845,535 B2	12/2010	Scircia	7,914,551 B2	3/2011	Ortiz et al.
7,845,536 B2	12/2010	Viola et al.	7,918,230 B2	4/2011	Whitman et al.
7,845,537 B2	12/2010	Shelton, IV et al.	7,918,376 B1	4/2011	Knodel et al.
7,845,538 B2	12/2010	Whitman	7,918,377 B2	4/2011	Measamer et al.
7,845,912 B2	12/2010	Sung et al.	7,918,845 B2	4/2011	Saadat et al.
7,846,085 B2	12/2010	Silverman et al.	7,918,848 B2	4/2011	Lau et al.
7,846,149 B2	12/2010	Jankowski	7,918,861 B2	4/2011	Brock et al.
7,846,161 B2	12/2010	Dumbauld et al.	7,918,867 B2	4/2011	Dana et al.
7,848,066 B2	12/2010	Yanagishima	7,922,061 B2	4/2011	Shelton, IV et al.
7,850,623 B2	12/2010	Griffin et al.	7,922,063 B2	4/2011	Zemlok et al.
7,850,642 B2	12/2010	Moll et al.	7,922,743 B2	4/2011	Heinrich et al.
7,850,982 B2	12/2010	Stopek et al.	7,923,144 B2	4/2011	Kohn et al.
7,853,813 B2	12/2010	Lee	7,926,691 B2	4/2011	Viola et al.
7,854,735 B2	12/2010	Houser et al.	7,926,692 B2	4/2011	Racenet et al.
7,854,736 B2	12/2010	Ryan	7,927,328 B2	4/2011	Orszulak et al.
7,857,183 B2	12/2010	Shelton, IV	7,928,281 B2	4/2011	Augustine
7,857,184 B2	12/2010	Viola	7,930,040 B1	4/2011	Kelsch et al.
7,857,185 B2	12/2010	Swayze et al.	7,930,065 B2	4/2011	Larkin et al.
7,857,186 B2	12/2010	Baxter, III et al.	7,931,660 B2	4/2011	Aranyi et al.
7,857,813 B2	12/2010	Schmitz et al.	7,931,695 B2	4/2011	Ringeisen
7,861,906 B2	1/2011	Doll et al.	7,931,877 B2	4/2011	Steffens et al.
7,862,502 B2	1/2011	Pool et al.	7,934,630 B2	5/2011	Shelton, IV et al.
7,862,546 B2	1/2011	Conlon et al.	7,934,631 B2	5/2011	Balbierz et al.
7,862,579 B2	1/2011	Ortiz et al.	7,934,896 B2	5/2011	Schnier
7,866,525 B2	1/2011	Scirica	7,935,130 B2	5/2011	Williams
7,866,527 B2	1/2011	Hall et al.	7,935,773 B2	5/2011	Hadba et al.
7,866,528 B2	1/2011	Olson et al.	7,936,142 B2	5/2011	Otsuka et al.
7,870,989 B2	1/2011	Viola et al.	7,938,307 B2	5/2011	Bettuchi
7,871,418 B2	1/2011	Thompson et al.	7,939,152 B2	5/2011	Haskin et al.
7,871,440 B2	1/2011	Schwartz et al.	7,941,865 B2	5/2011	Seman, Jr. et al.
7,875,055 B2	1/2011	Cichocki, Jr.	7,942,300 B2	5/2011	Rethy et al.
7,879,063 B2	2/2011	Khosravi	7,942,303 B2	5/2011	Shah
7,879,070 B2	2/2011	Ortiz et al.	7,942,890 B2	5/2011	D'Agostino et al.
7,883,461 B2	2/2011	Albrecht et al.	7,944,175 B2	5/2011	Mori et al.
7,883,465 B2	2/2011	Donofrio et al.	7,945,792 B2	5/2011	Cherpantier
7,883,540 B2	2/2011	Niwa et al.	7,945,798 B2	5/2011	Carlson et al.
7,886,951 B2	2/2011	Hessler	7,946,453 B2	5/2011	Voegele et al.
7,886,952 B2	2/2011	Scirica et al.	7,947,011 B2	5/2011	Birk et al.
7,887,530 B2	2/2011	Zemlok et al.	7,948,381 B2	5/2011	Lindsay et al.
7,887,535 B2	2/2011	Lands et al.	7,950,560 B2	5/2011	Zemlok et al.
7,887,536 B2	2/2011	Johnson et al.	7,950,561 B2	5/2011	Aranyi
7,887,563 B2	2/2011	Cummins	7,950,562 B2	5/2011	Beardsley et al.
7,887,755 B2	2/2011	Mingerink et al.	7,951,071 B2	5/2011	Whitman et al.
7,891,531 B1	2/2011	Ward	7,951,166 B2	5/2011	Orban, III et al.
7,891,532 B2	2/2011	Mastri et al.	7,954,682 B2	6/2011	Giordano et al.
7,892,200 B2	2/2011	Birk et al.	7,954,684 B2	6/2011	Boudreaux
7,892,245 B2	2/2011	Liddicoat et al.	7,954,685 B2	6/2011	Viola
7,893,586 B2	2/2011	West et al.	7,954,686 B2	6/2011	Baxter, III et al.
7,896,214 B2	3/2011	Farascioni	7,954,687 B2	6/2011	Zemlok et al.
7,896,215 B2	3/2011	Adams et al.	7,954,688 B2	6/2011	Argentine et al.
7,896,671 B2	3/2011	Kim et al.	7,955,253 B2	6/2011	Ewers et al.
7,896,869 B2	3/2011	DiSilvestro et al.	7,955,257 B2	6/2011	Frasier et al.
			7,955,322 B2	6/2011	Devengenzo et al.
			7,955,327 B2	6/2011	Sartor et al.
			7,955,380 B2	6/2011	Chu et al.
			7,959,050 B2	6/2011	Smith et al.

(56)

References Cited

U.S. PATENT DOCUMENTS

7,959,051 B2	6/2011	Smith et al.	8,029,510 B2	10/2011	Hoegerle
7,959,052 B2	6/2011	Sonnenschein et al.	8,031,069 B2	10/2011	Cohn et al.
7,963,432 B2	6/2011	Knodel et al.	8,033,438 B2	10/2011	Scirica
7,963,433 B2	6/2011	Whitman et al.	8,033,439 B2	10/2011	Racenet et al.
7,963,913 B2	6/2011	Devengenzo et al.	8,033,440 B2	10/2011	Wenchell et al.
7,963,963 B2	6/2011	Francischelli et al.	8,033,442 B2	10/2011	Racenet et al.
7,963,964 B2	6/2011	Santilli et al.	8,034,077 B2	10/2011	Smith et al.
7,964,206 B2	6/2011	Suokas et al.	8,034,337 B2	10/2011	Simard
7,966,236 B2	6/2011	Noriega et al.	8,034,363 B2	10/2011	Li et al.
7,966,269 B2	6/2011	Bauer et al.	8,035,487 B2	10/2011	Malackowski
7,966,799 B2	6/2011	Morgan et al.	8,037,591 B2	10/2011	Spivey et al.
7,967,178 B2	6/2011	Scirica et al.	8,038,044 B2	10/2011	Viola
7,967,179 B2	6/2011	Olson et al.	8,038,045 B2	10/2011	Bettuchi et al.
7,967,180 B2	6/2011	Scirica	8,038,046 B2	10/2011	Smith et al.
7,967,181 B2	6/2011	Viola et al.	8,038,686 B2	10/2011	Huitema et al.
7,967,791 B2	6/2011	Franer et al.	8,043,207 B2	10/2011	Adams
7,967,839 B2	6/2011	Flock et al.	8,043,328 B2	10/2011	Hahnen et al.
7,972,298 B2	7/2011	Wallace et al.	8,044,536 B2	10/2011	Nguyen et al.
7,972,315 B2	7/2011	Birk et al.	8,044,604 B2	10/2011	Hagino et al.
7,976,213 B2	7/2011	Bertolotti et al.	8,047,236 B2	11/2011	Perry
7,976,508 B2	7/2011	Hoag	8,048,503 B2	11/2011	Farnsworth et al.
7,976,563 B2	7/2011	Summerer	8,052,636 B2	11/2011	Moll et al.
7,979,137 B2	7/2011	Tracey et al.	8,056,787 B2	11/2011	Boudreaux et al.
7,980,443 B2	7/2011	Scheib et al.	8,056,788 B2	11/2011	Mastri et al.
7,981,025 B2	7/2011	Pool et al.	8,056,789 B1	11/2011	White et al.
7,981,102 B2	7/2011	Patel et al.	8,057,508 B2	11/2011	Shelton, IV
7,981,132 B2	7/2011	Dubrul et al.	8,058,771 B2	11/2011	Giordano et al.
7,987,405 B2	7/2011	Turner et al.	8,060,250 B2	11/2011	Reiland et al.
7,988,015 B2	8/2011	Mason, II et al.	8,061,014 B2	11/2011	Smith et al.
7,988,026 B2	8/2011	Knodel et al.	8,061,576 B2	11/2011	Cappola
7,988,027 B2	8/2011	Olson et al.	8,062,236 B2	11/2011	Soltz
7,988,028 B2	8/2011	Farascioni et al.	8,062,306 B2	11/2011	Nobis et al.
7,988,779 B2	8/2011	Disalvo et al.	8,062,330 B2	11/2011	Prommersberger et al.
7,992,757 B2	8/2011	Wheeler et al.	8,063,619 B2	11/2011	Zhu et al.
7,993,360 B2	8/2011	Hacker et al.	8,066,158 B2	11/2011	Vogel et al.
7,994,670 B2	8/2011	Ji	8,066,166 B2	11/2011	Demmy et al.
7,997,054 B2	8/2011	Bertsch et al.	8,066,167 B2	11/2011	Measamer et al.
7,997,468 B2	8/2011	Farascioni	8,066,168 B2	11/2011	Vidal et al.
7,997,469 B2	8/2011	Olson et al.	8,066,720 B2	11/2011	Knodel et al.
8,002,696 B2	8/2011	Suzuki	D650,074 S	12/2011	Hunt et al.
8,002,784 B2	8/2011	Jinno et al.	D650,789 S	12/2011	Arnold
8,002,785 B2	8/2011	Weiss et al.	8,070,033 B2	12/2011	Milliman et al.
8,002,795 B2	8/2011	Beetel	8,070,034 B1	12/2011	Knodel
8,006,365 B2	8/2011	Levin et al.	8,070,035 B2	12/2011	Holsten et al.
8,006,885 B2	8/2011	Marczyk	8,070,743 B2	12/2011	Kagan et al.
8,006,889 B2	8/2011	Adams et al.	8,074,858 B2	12/2011	Marczyk
8,007,370 B2	8/2011	Hirsch et al.	8,074,859 B2	12/2011	Kostrzewski
8,007,465 B2	8/2011	Birk et al.	8,074,861 B2	12/2011	Ehrenfels et al.
8,007,479 B2	8/2011	Birk et al.	8,075,476 B2	12/2011	Vargas
8,007,511 B2	8/2011	Brock et al.	8,075,571 B2	12/2011	Vitali et al.
8,007,513 B2	8/2011	Nalagatla et al.	8,079,950 B2	12/2011	Stern et al.
8,008,598 B2	8/2011	Whitman et al.	8,079,989 B2	12/2011	Birk et al.
8,010,180 B2	8/2011	Quaid et al.	8,080,004 B2	12/2011	Downey et al.
8,011,550 B2	9/2011	Aranyi et al.	8,083,118 B2	12/2011	Milliman et al.
8,011,551 B2	9/2011	Marczyk et al.	8,083,119 B2	12/2011	Prommersberger
8,011,553 B2	9/2011	Mastri et al.	8,083,120 B2	12/2011	Shelton, IV et al.
8,011,555 B2	9/2011	Tarinelli et al.	8,084,001 B2	12/2011	Burns et al.
8,012,170 B2	9/2011	Whitman et al.	8,084,969 B2	12/2011	David et al.
8,016,176 B2	9/2011	Kasvikis et al.	8,085,013 B2	12/2011	Wei et al.
8,016,177 B2	9/2011	Bettuchi et al.	8,087,562 B1	1/2012	Manoux et al.
8,016,178 B2	9/2011	Olson et al.	8,087,563 B2	1/2012	Milliman et al.
8,016,849 B2	9/2011	Wenchell	8,089,509 B2	1/2012	Chatenever et al.
8,016,855 B2	9/2011	Whitman et al.	8,091,753 B2	1/2012	Viola
8,016,858 B2	9/2011	Whitman	8,091,756 B2	1/2012	Viola
8,016,881 B2	9/2011	Furst	8,092,443 B2	1/2012	Bischoff
8,020,742 B2	9/2011	Marczyk	8,092,932 B2	1/2012	Phillips et al.
8,020,743 B2	9/2011	Shelton, IV	8,093,572 B2	1/2012	Kuduvalli
8,021,375 B2	9/2011	Aldrich et al.	8,096,458 B2	1/2012	Hessler
8,025,199 B2	9/2011	Whitman et al.	8,096,459 B2	1/2012	Ortiz et al.
8,025,896 B2	9/2011	Malaviya et al.	8,097,017 B2	1/2012	Viola
8,028,835 B2	10/2011	Yasuda et al.	8,100,310 B2	1/2012	Zemlok
8,028,882 B2	10/2011	Viola	8,100,824 B2	1/2012	Hegeman et al.
8,028,883 B2	10/2011	Stopek	8,100,872 B2	1/2012	Patel
8,028,884 B2	10/2011	Sniffin et al.	8,102,138 B2	1/2012	Sekine et al.
8,028,885 B2	10/2011	Smith et al.	8,102,278 B2	1/2012	Deck et al.
			8,105,320 B2	1/2012	Manzo
			8,105,350 B2	1/2012	Lee et al.
			8,107,925 B2	1/2012	Natsuno et al.
			8,108,033 B2	1/2012	Drew et al.

(56)

References Cited

U.S. PATENT DOCUMENTS

8,108,072 B2	1/2012	Zhao et al.	8,181,839 B2	5/2012	Beetel
8,109,426 B2	2/2012	Milliman et al.	8,181,840 B2	5/2012	Milliman
8,110,208 B1	2/2012	Hen	8,182,422 B2	5/2012	Bayer et al.
8,113,405 B2	2/2012	Milliman	8,182,444 B2	5/2012	Uber, III et al.
8,113,407 B2	2/2012	Holsten et al.	8,183,807 B2	5/2012	Tsai et al.
8,113,408 B2	2/2012	Wenchell et al.	8,186,555 B2	5/2012	Shelton, IV et al.
8,113,410 B2	2/2012	Hall et al.	8,186,556 B2	5/2012	Viola
8,114,017 B2	2/2012	Bacher	8,186,558 B2	5/2012	Sapienza
8,114,100 B2	2/2012	Smith et al.	8,186,560 B2	5/2012	Hess et al.
8,114,345 B2	2/2012	Dlugos, Jr. et al.	8,190,238 B2	5/2012	Moll et al.
8,118,206 B2	2/2012	Zand et al.	8,191,752 B2	6/2012	Scirica
8,118,207 B2	2/2012	Racenet et al.	8,192,350 B2	6/2012	Ortiz et al.
8,120,301 B2	2/2012	Goldberg et al.	8,192,460 B2	6/2012	Orban, III et al.
8,122,128 B2	2/2012	Burke, II et al.	8,192,651 B2	6/2012	Young et al.
8,123,103 B2	2/2012	Milliman	8,193,129 B2	6/2012	Tagawa et al.
8,123,523 B2	2/2012	Carron et al.	8,196,795 B2	6/2012	Moore et al.
8,123,766 B2	2/2012	Bauman et al.	8,196,796 B2	6/2012	Shelton, IV et al.
8,123,767 B2	2/2012	Bauman et al.	8,197,501 B2	6/2012	Shadeck et al.
8,125,168 B2	2/2012	Johnson et al.	8,197,502 B2	6/2012	Smith et al.
8,127,975 B2	3/2012	Olson et al.	8,197,837 B2	6/2012	Jamiolkowski et al.
8,127,976 B2	3/2012	Scirica et al.	8,201,720 B2	6/2012	Hessler
8,128,624 B2	3/2012	Couture et al.	8,201,721 B2	6/2012	Zemlok et al.
8,128,643 B2	3/2012	Aranyi et al.	8,202,549 B2	6/2012	Stucky et al.
8,128,645 B2	3/2012	Sonnenschein et al.	8,205,779 B2	6/2012	Ma et al.
8,128,662 B2	3/2012	Altarac et al.	8,205,780 B2	6/2012	Sorrentino et al.
8,132,703 B2	3/2012	Milliman et al.	8,205,781 B2	6/2012	Baxter, III et al.
8,132,705 B2	3/2012	Viola et al.	8,207,863 B2	6/2012	Neubauer et al.
8,132,706 B2	3/2012	Marczyk et al.	8,210,411 B2	7/2012	Yates et al.
8,133,500 B2	3/2012	Ringeisen et al.	8,210,414 B2	7/2012	Bettuchi et al.
8,134,306 B2	3/2012	Drader et al.	8,210,415 B2	7/2012	Ward
8,136,711 B2	3/2012	Beardsley et al.	8,210,416 B2	7/2012	Milliman et al.
8,136,712 B2	3/2012	Zingman	8,210,721 B2	7/2012	Chen et al.
8,136,713 B2	3/2012	Hathaway et al.	8,211,125 B2	7/2012	Spivey
8,137,339 B2	3/2012	Jinno et al.	8,214,019 B2	7/2012	Govari et al.
8,140,417 B2	3/2012	Shibata	8,215,531 B2	7/2012	Shelton, IV et al.
8,141,762 B2	3/2012	Bedi et al.	8,215,532 B2	7/2012	Marczyk
8,141,763 B2	3/2012	Milliman	8,215,533 B2	7/2012	Viola et al.
8,142,200 B2	3/2012	Crunkilton et al.	8,220,468 B2	7/2012	Cooper et al.
8,142,425 B2	3/2012	Eggers	8,220,688 B2	7/2012	Laurent et al.
8,142,461 B2	3/2012	Houser et al.	8,220,690 B2	7/2012	Hess et al.
8,142,515 B2	3/2012	Therin et al.	8,221,402 B2	7/2012	Francischelli et al.
8,143,520 B2	3/2012	Cutler	8,221,424 B2	7/2012	Cha
8,146,790 B2	4/2012	Milliman	8,221,433 B2	7/2012	Lozier et al.
8,147,421 B2	4/2012	Farquhar et al.	8,225,799 B2	7/2012	Bettuchi
8,147,456 B2	4/2012	Fisher et al.	8,225,979 B2	7/2012	Farascioni et al.
8,147,485 B2	4/2012	Wham et al.	8,226,553 B2	7/2012	Shelton, IV et al.
8,152,041 B2	4/2012	Kostrzewski	8,226,635 B2	7/2012	Petrie et al.
8,152,756 B2	4/2012	Webster et al.	8,226,675 B2	7/2012	Houser et al.
8,154,239 B2	4/2012	Katsuki et al.	8,226,715 B2	7/2012	Hwang et al.
8,157,145 B2	4/2012	Shelton, IV et al.	8,227,946 B2	7/2012	Kim
8,157,148 B2	4/2012	Scirica	8,228,020 B2	7/2012	Shin et al.
8,157,151 B2	4/2012	Ingmanson et al.	8,228,048 B2	7/2012	Spencer
8,157,152 B2	4/2012	Holsten et al.	8,229,549 B2	7/2012	Whitman et al.
8,157,153 B2	4/2012	Shelton, IV et al.	8,231,040 B2	7/2012	Zemlok et al.
8,157,793 B2	4/2012	Omori et al.	8,231,042 B2	7/2012	Hessler et al.
8,157,834 B2	4/2012	Conlon	8,231,043 B2	7/2012	Tarinelli et al.
8,161,977 B2	4/2012	Shelton, IV et al.	8,235,272 B2	8/2012	Nicholas et al.
8,162,138 B2	4/2012	Bettenhausen et al.	8,235,274 B2	8/2012	Cappola
8,162,197 B2	4/2012	Mastri et al.	8,236,010 B2	8/2012	Ortiz et al.
8,162,668 B2	4/2012	Toly	8,236,011 B2	8/2012	Harris et al.
8,162,933 B2	4/2012	Francischelli et al.	8,236,020 B2	8/2012	Smith et al.
8,162,965 B2	4/2012	Reschke et al.	8,237,388 B2	8/2012	Jinno et al.
8,167,185 B2	5/2012	Shelton, IV et al.	8,240,537 B2	8/2012	Marczyk
8,167,622 B2	5/2012	Zhou	8,241,271 B2	8/2012	Millman et al.
8,167,895 B2	5/2012	D'Agostino et al.	8,241,284 B2	8/2012	Dycus et al.
8,167,898 B1	5/2012	Schaller et al.	8,241,308 B2	8/2012	Kortenbach et al.
8,170,241 B2	5/2012	Roe et al.	8,241,322 B2	8/2012	Whitman et al.
8,172,004 B2	5/2012	Ho	8,245,594 B2	8/2012	Rogers et al.
8,172,120 B2	5/2012	Boyden et al.	8,245,898 B2	8/2012	Smith et al.
8,172,122 B2	5/2012	Kasvikis et al.	8,245,899 B2	8/2012	Swensgard et al.
8,172,124 B2	5/2012	Shelton, IV et al.	8,245,900 B2	8/2012	Scirica
8,177,776 B2	5/2012	Humayun et al.	8,245,901 B2	8/2012	Stope
8,177,797 B2	5/2012	Shimoji et al.	8,246,608 B2	8/2012	Omori et al.
8,179,705 B2	5/2012	Chapuis	8,246,637 B2	8/2012	Viola et al.
8,180,458 B2	5/2012	Kane et al.	8,252,009 B2	8/2012	Weller et al.
			8,256,654 B2	9/2012	Bettuchi et al.
			8,256,655 B2	9/2012	Sniffin et al.
			8,256,656 B2	9/2012	Milliman et al.
			8,257,251 B2	9/2012	Shelton, IV et al.

(56)

References Cited

U.S. PATENT DOCUMENTS

8,257,356 B2	9/2012	Bleich et al.	D672,784 S	12/2012	Clanton et al.
8,257,386 B2	9/2012	Lee et al.	8,322,455 B2	12/2012	Shelton, IV et al.
8,257,391 B2	9/2012	Orban, III et al.	8,322,589 B2	12/2012	Boudreaux
8,257,634 B2	9/2012	Scirica	8,322,590 B2	12/2012	Patel et al.
8,258,745 B2	9/2012	Smith et al.	8,322,901 B2	12/2012	Michelotti
8,261,958 B1	9/2012	Knodel	8,323,271 B2	12/2012	Humayun et al.
8,262,560 B2	9/2012	Whitman	8,323,789 B2	12/2012	Rozhin et al.
8,262,655 B2	9/2012	Ghabrial et al.	8,324,585 B2	12/2012	McBroom et al.
8,266,232 B2	9/2012	Piper et al.	8,327,514 B2	12/2012	Kim
8,267,300 B2	9/2012	Boudreaux	8,328,061 B2	12/2012	Kasvikis
8,267,849 B2	9/2012	Wazer et al.	8,328,062 B2	12/2012	Viola
8,267,924 B2	9/2012	Zemlok et al.	8,328,063 B2	12/2012	Milliman et al.
8,267,946 B2	9/2012	Whitfield et al.	8,328,064 B2	12/2012	Racenet et al.
8,267,951 B2	9/2012	Whayne et al.	8,328,065 B2	12/2012	Shah
8,268,344 B2	9/2012	Ma et al.	8,328,802 B2	12/2012	Deville et al.
8,269,121 B2	9/2012	Smith	8,328,823 B2	12/2012	Aranyi et al.
8,272,553 B2	9/2012	Mastri et al.	8,333,313 B2	12/2012	Boudreaux et al.
8,272,554 B2	9/2012	Whitman et al.	8,333,691 B2	12/2012	Schaaf
8,272,918 B2	9/2012	Lam	8,333,764 B2	12/2012	Francischelli et al.
8,273,404 B2	9/2012	Dave et al.	8,333,779 B2	12/2012	Smith et al.
8,276,594 B2	10/2012	Shah	8,334,468 B2	12/2012	Palmer et al.
8,276,801 B2	10/2012	Zemlok et al.	8,336,753 B2	12/2012	Olson et al.
8,276,802 B2	10/2012	Kostrzewski	8,336,754 B2	12/2012	Cappola et al.
8,277,473 B2	10/2012	Sunaoshi et al.	8,342,377 B2	1/2013	Milliman et al.
8,281,446 B2	10/2012	Moskovich	8,342,378 B2	1/2013	Marczyk et al.
8,281,973 B2	10/2012	Wenchell et al.	8,342,379 B2	1/2013	Whitman et al.
8,281,974 B2	10/2012	Hessler et al.	8,342,380 B2	1/2013	Viola
8,282,654 B2	10/2012	Ferrari et al.	8,343,150 B2	1/2013	Artale
8,285,367 B2	10/2012	Hyde et al.	8,347,978 B2	1/2013	Forster et al.
8,286,723 B2	10/2012	Puzio et al.	8,348,118 B2	1/2013	Segura
8,286,845 B2	10/2012	Perry et al.	8,348,123 B2	1/2013	Scirica et al.
8,286,846 B2	10/2012	Smith et al.	8,348,124 B2	1/2013	Scirica
8,286,847 B2	10/2012	Taylor	8,348,125 B2	1/2013	Viola et al.
8,287,487 B2	10/2012	Estes	8,348,126 B2	1/2013	Olson et al.
8,287,522 B2	10/2012	Moses et al.	8,348,127 B2	1/2013	Marczyk
8,287,561 B2	10/2012	Nunez et al.	8,348,129 B2	1/2013	Bedi et al.
8,288,984 B2	10/2012	Yang	8,348,130 B2	1/2013	Shah et al.
8,289,403 B2	10/2012	Dobashi et al.	8,348,131 B2	1/2013	Omaits et al.
8,290,883 B2	10/2012	Takeuchi et al.	8,348,837 B2	1/2013	Wenchell
8,292,147 B2	10/2012	Viola	8,348,959 B2	1/2013	Wolford et al.
8,292,148 B2	10/2012	Viola	8,348,972 B2	1/2013	Soltz et al.
8,292,150 B2	10/2012	Bryant	8,349,987 B2	1/2013	Kapiamba et al.
8,292,151 B2	10/2012	Viola	8,352,004 B2	1/2013	Mannheimer et al.
8,292,152 B2	10/2012	Milliman et al.	8,353,437 B2	1/2013	Boudreaux
8,292,155 B2	10/2012	Shelton, IV et al.	8,353,438 B2	1/2013	Baxter, III et al.
8,292,157 B2	10/2012	Smith et al.	8,353,439 B2	1/2013	Baxter, III et al.
8,292,158 B2	10/2012	Sapienza	8,356,740 B1	1/2013	Knodel
8,292,801 B2	10/2012	Dejima et al.	8,357,144 B2	1/2013	Whitman et al.
8,292,888 B2	10/2012	Whitman	8,357,158 B2	1/2013	McKenna et al.
8,292,906 B2	10/2012	Taylor et al.	8,357,161 B2	1/2013	Mueller
8,294,399 B2	10/2012	Suzuki et al.	8,359,174 B2	1/2013	Nakashima et al.
8,298,161 B2	10/2012	Vargas	8,360,296 B2	1/2013	Zingman
8,298,189 B2	10/2012	Fisher et al.	8,360,297 B2	1/2013	Shelton, IV et al.
8,298,233 B2	10/2012	Mueller	8,360,298 B2	1/2013	Farascioni et al.
8,298,677 B2	10/2012	Wiesner et al.	8,360,299 B2	1/2013	Zemlok et al.
8,302,323 B2	11/2012	Fortier et al.	8,361,501 B2	1/2013	DiTizio et al.
8,303,621 B2	11/2012	Miyamoto et al.	D676,866 S	2/2013	Chaudhri
8,308,040 B2	11/2012	Huang et al.	8,365,972 B2	2/2013	Aranyi et al.
8,308,041 B2	11/2012	Kostrzewski	8,365,973 B1	2/2013	White et al.
8,308,042 B2	11/2012	Aranyi	8,365,975 B1	2/2013	Manoux et al.
8,308,043 B2	11/2012	Bindra et al.	8,365,976 B2	2/2013	Hess et al.
8,308,046 B2	11/2012	Prommersberger	8,366,559 B2	2/2013	Papenfuss et al.
8,308,659 B2	11/2012	Scheibe et al.	8,366,719 B2	2/2013	Markey et al.
8,308,725 B2	11/2012	Bell et al.	8,366,787 B2	2/2013	Brown et al.
8,310,188 B2	11/2012	Nakai	8,368,327 B2	2/2013	Benning et al.
8,313,496 B2	11/2012	Sauer et al.	8,369,056 B2	2/2013	Senriuchi et al.
8,313,499 B2	11/2012	Magnusson et al.	8,371,393 B2	2/2013	Higuchi et al.
8,313,509 B2	11/2012	Kostrzewski	8,371,491 B2	2/2013	Huitema et al.
8,317,070 B2	11/2012	Hueil et al.	8,371,492 B2	2/2013	Aranyi et al.
8,317,071 B1	11/2012	Knodel	8,371,493 B2	2/2013	Aranyi et al.
8,317,074 B2	11/2012	Ortiz et al.	8,371,494 B2	2/2013	Racenet et al.
8,317,437 B2	11/2012	Merkley et al.	8,372,094 B2	2/2013	Bettuchi et al.
8,317,744 B2	11/2012	Kirschenman	8,374,723 B2	2/2013	Zhao et al.
8,317,790 B2	11/2012	Bell et al.	8,376,865 B2	2/2013	Forster et al.
8,319,002 B2	11/2012	Daniels et al.	8,377,029 B2	2/2013	Nagao et al.
			8,377,044 B2	2/2013	Coe et al.
			8,377,059 B2	2/2013	Deville et al.
			8,381,828 B2	2/2013	Whitman et al.
			8,382,773 B2	2/2013	Whitfield et al.

(56)

References Cited

U.S. PATENT DOCUMENTS

8,382,790 B2	2/2013	Uenohara et al.	8,453,908 B2	6/2013	Bedi et al.
D677,273 S	3/2013	Randall et al.	8,453,912 B2	6/2013	Mastri et al.
8,387,848 B2	3/2013	Johnson et al.	8,453,914 B2	6/2013	Laurent et al.
8,388,633 B2	3/2013	Rousseau et al.	8,454,495 B2	6/2013	Kawano et al.
8,389,588 B2	3/2013	Ringeisen et al.	8,454,551 B2	6/2013	Allen et al.
8,393,513 B2	3/2013	Jankowski	8,454,628 B2	6/2013	Smith et al.
8,393,514 B2	3/2013	Shelton, IV et al.	8,454,640 B2	6/2013	Johnston et al.
8,393,516 B2	3/2013	Kostrzewski	8,457,757 B2	6/2013	Cauller et al.
8,397,832 B2	3/2013	Blickle et al.	8,459,520 B2	6/2013	Giordano et al.
8,397,971 B2	3/2013	Yates et al.	8,459,521 B2	6/2013	Zemlok et al.
8,397,972 B2	3/2013	Kostrzewski	8,459,524 B2	6/2013	Pribanic et al.
8,397,973 B1	3/2013	Hausen	8,459,525 B2	6/2013	Yates et al.
8,398,633 B2	3/2013	Mueller	8,464,922 B2	6/2013	Marczyk
8,398,669 B2	3/2013	Kim	8,464,923 B2	6/2013	Shelton, IV
8,398,673 B2	3/2013	Hinchliffe et al.	8,464,924 B2	6/2013	Gresham et al.
8,398,674 B2	3/2013	Prestel	8,464,925 B2	6/2013	Hull et al.
8,400,108 B2	3/2013	Powell et al.	8,465,475 B2	6/2013	Isbell, Jr.
8,400,851 B2	3/2013	Byun	8,465,502 B2	6/2013	Zergiebel
8,403,138 B2	3/2013	Weisshaupt et al.	8,465,515 B2	6/2013	Drew et al.
8,403,195 B2	3/2013	Beardsley et al.	8,469,254 B2	6/2013	Czernik et al.
8,403,196 B2	3/2013	Beardsley et al.	8,469,946 B2	6/2013	Sugita
8,403,198 B2	3/2013	Sorrentino et al.	8,469,973 B2	6/2013	Meade et al.
8,403,832 B2	3/2013	Cunningham et al.	8,470,355 B2	6/2013	Skalla et al.
8,403,926 B2	3/2013	Nobis et al.	D686,240 S	7/2013	Lin
8,403,945 B2	3/2013	Whitfield et al.	D686,244 S	7/2013	Moriya et al.
8,403,946 B2	3/2013	Whitfield et al.	8,474,677 B2	7/2013	Woodard, Jr. et al.
8,403,950 B2	3/2013	Palmer et al.	8,475,453 B2	7/2013	Marczyk et al.
D680,646 S	4/2013	Hunt et al.	8,475,454 B1	7/2013	Alshemari
8,408,439 B2	4/2013	Huang et al.	8,475,474 B2	7/2013	Bombard et al.
8,408,442 B2	4/2013	Racenet et al.	8,479,968 B2	7/2013	Hodgkinson et al.
8,409,079 B2	4/2013	Okamoto et al.	8,479,969 B2	7/2013	Shelton, IV
8,409,174 B2	4/2013	Omori	8,480,703 B2	7/2013	Nicholas et al.
8,409,175 B2	4/2013	Lee et al.	8,483,509 B2	7/2013	Matsuzaka
8,409,211 B2	4/2013	Baroud	8,485,412 B2	7/2013	Shelton, IV et al.
8,409,222 B2	4/2013	Whitfield et al.	8,485,413 B2	7/2013	Scheib et al.
8,409,223 B2	4/2013	Sorrentino et al.	8,485,970 B2	7/2013	Widenhouse et al.
8,411,500 B2	4/2013	Gapihan et al.	8,486,047 B2	7/2013	Stope
8,413,661 B2	4/2013	Rousseau et al.	8,487,199 B2	7/2013	Palmer et al.
8,413,870 B2	4/2013	Pastorelli et al.	8,487,487 B2	7/2013	Dietz et al.
8,413,871 B2	4/2013	Racenet et al.	8,490,851 B2	7/2013	Blier et al.
8,413,872 B2	4/2013	Patel	8,490,852 B2	7/2013	Viola
8,414,469 B2	4/2013	Diolaiti	8,490,853 B2	7/2013	Criscuolo et al.
8,414,577 B2	4/2013	Boudreaux et al.	8,491,581 B2	7/2013	Deville et al.
8,414,598 B2	4/2013	Brock et al.	8,491,603 B2	7/2013	Yeung et al.
8,418,073 B2	4/2013	Mohr et al.	8,496,153 B2	7/2013	Demmy et al.
8,418,906 B2	4/2013	Farascioni et al.	8,496,154 B2	7/2013	Marczyk et al.
8,418,907 B2	4/2013	Johnson et al.	8,496,156 B2	7/2013	Sniffin et al.
8,418,908 B1	4/2013	Beardsley	8,496,683 B2	7/2013	Prommersberger et al.
8,418,909 B2	4/2013	Kostrzewski	8,498,691 B2	7/2013	Moll et al.
8,419,635 B2	4/2013	Shelton, IV et al.	8,499,673 B2	8/2013	Keller
8,419,717 B2	4/2013	Diolaiti et al.	8,499,966 B2	8/2013	Palmer et al.
8,419,747 B2	4/2013	Hinman et al.	8,499,992 B2	8/2013	Whitman et al.
8,419,754 B2	4/2013	Laby et al.	8,499,993 B2	8/2013	Shelton, IV et al.
8,419,755 B2	4/2013	Deem et al.	8,499,994 B2	8/2013	D'Arcangelo
8,423,182 B2	4/2013	Robinson et al.	8,500,721 B2	8/2013	Jinno
8,424,737 B2	4/2013	Scirica	8,500,762 B2	8/2013	Sholev et al.
8,424,739 B2	4/2013	Racenet et al.	8,502,091 B2	8/2013	Palmer et al.
8,424,740 B2	4/2013	Shelton, IV et al.	8,505,799 B2	8/2013	Viola et al.
8,424,741 B2	4/2013	McGuckin, Jr. et al.	8,505,801 B2	8/2013	Ehrenfels et al.
8,425,600 B2	4/2013	Maxwell	8,506,555 B2	8/2013	Ruiz Morales
8,427,430 B2	4/2013	Lee et al.	8,506,557 B2	8/2013	Zemlok et al.
8,430,292 B2	4/2013	Patel et al.	8,506,580 B2	8/2013	Zergiebel et al.
8,430,892 B2	4/2013	Bindra et al.	8,506,581 B2	8/2013	Wingardner, III et al.
8,430,898 B2	4/2013	Wiener et al.	8,511,308 B2	8/2013	Hecox et al.
8,435,257 B2	5/2013	Smith et al.	8,512,359 B2	8/2013	Whitman et al.
8,439,246 B1	5/2013	Knodel	8,512,402 B2	8/2013	Marczyk et al.
8,439,830 B2	5/2013	McKinley et al.	8,517,239 B2	8/2013	Scheib et al.
8,444,036 B2	5/2013	Shelton, IV	8,517,241 B2	8/2013	Nicholas et al.
8,444,037 B2	5/2013	Nicholas et al.	8,517,243 B2	8/2013	Giordano et al.
8,444,549 B2	5/2013	Viola et al.	8,517,244 B2	8/2013	Shelton, IV et al.
8,449,536 B2	5/2013	Selig	8,517,938 B2	8/2013	Eisenhardt et al.
8,449,560 B2	5/2013	Roth et al.	8,518,024 B2	8/2013	Williams et al.
8,453,904 B2	6/2013	Eskaros et al.	8,521,273 B2	8/2013	Kliman
8,453,906 B2	6/2013	Huang et al.	8,523,042 B2	9/2013	Masiakos et al.
8,453,907 B2	6/2013	Laurent et al.	8,523,043 B2	9/2013	Ullrich et al.
			8,523,787 B2	9/2013	Ludwin et al.
			8,523,881 B2	9/2013	Cabiri et al.
			8,523,882 B2	9/2013	Huitema et al.
			8,523,900 B2	9/2013	Jinno et al.

(56)

References Cited

U.S. PATENT DOCUMENTS

8,529,588 B2	9/2013	Ahlberg et al.	8,616,431 B2	12/2013	Timm et al.
8,529,599 B2	9/2013	Holsten	8,617,155 B2	12/2013	Johnson et al.
8,529,600 B2	9/2013	Woodard, Jr. et al.	8,620,473 B2	12/2013	Diolaiti et al.
8,529,819 B2	9/2013	Ostapoff et al.	8,622,274 B2	1/2014	Yates et al.
8,532,747 B2	9/2013	Nock et al.	8,622,275 B2	1/2014	Baxter, III et al.
8,534,527 B2	9/2013	Brendel et al.	8,627,993 B2	1/2014	Smith et al.
8,534,528 B2	9/2013	Shelton, IV	8,627,994 B2	1/2014	Zemlok et al.
8,535,304 B2	9/2013	Sklar et al.	8,627,995 B2	1/2014	Smith et al.
8,535,340 B2	9/2013	Allen	8,628,467 B2	1/2014	Whitman et al.
8,539,866 B2	9/2013	Nayak et al.	8,628,518 B2	1/2014	Blumenkranz et al.
8,540,128 B2	9/2013	Shelton, IV et al.	8,628,544 B2	1/2014	Farascioni
8,540,129 B2	9/2013	Baxter, III et al.	8,628,545 B2	1/2014	Cabrera et al.
8,540,130 B2	9/2013	Moore et al.	8,631,987 B2	1/2014	Shelton, IV et al.
8,540,131 B2	9/2013	Swayze	8,631,992 B1	1/2014	Hausen et al.
8,540,133 B2	9/2013	Bedi et al.	8,631,993 B2	1/2014	Kostrzewski
8,540,646 B2	9/2013	Mendez-Coll	8,632,462 B2	1/2014	Yoo et al.
8,540,733 B2	9/2013	Whitman et al.	8,632,525 B2	1/2014	Kerr et al.
8,540,735 B2	9/2013	Mitelberg et al.	8,632,535 B2	1/2014	Shelton, IV et al.
8,550,984 B2	10/2013	Takemoto	8,632,539 B2	1/2014	Twomey et al.
8,551,076 B2	10/2013	Duval et al.	8,632,563 B2	1/2014	Nagase et al.
8,555,660 B2	10/2013	Takenaka et al.	8,636,187 B2	1/2014	Hueil et al.
8,556,151 B2	10/2013	Viola	8,636,190 B2	1/2014	Zemlok et al.
8,556,918 B2	10/2013	Bauman et al.	8,636,191 B2	1/2014	Meagher
8,556,935 B1	10/2013	Knodel et al.	8,636,193 B2	1/2014	Whitman et al.
8,560,147 B2	10/2013	Taylor et al.	8,636,736 B2	1/2014	Yates et al.
8,561,617 B2	10/2013	Lindh et al.	8,636,766 B2	1/2014	Milliman et al.
8,561,870 B2	10/2013	Baxter, III et al.	8,639,936 B2	1/2014	Hu et al.
8,561,871 B2	10/2013	Rajappa et al.	8,640,788 B2	2/2014	Dachs, II et al.
8,561,873 B2	10/2013	Ingmanson et al.	8,646,674 B2	2/2014	Schulte et al.
8,562,592 B2	10/2013	Conlon et al.	8,647,258 B2	2/2014	Aranyi et al.
8,562,598 B2	10/2013	Falkenstein et al.	8,652,120 B2	2/2014	Giordano et al.
8,567,656 B2	10/2013	Shelton, IV et al.	8,652,151 B2	2/2014	Lehman et al.
8,568,416 B2	10/2013	Schmitz et al.	8,652,155 B2	2/2014	Houser et al.
8,568,425 B2	10/2013	Ross et al.	8,656,929 B2	2/2014	Miller et al.
D692,916 S	11/2013	Granchi et al.	8,657,174 B2	2/2014	Yates et al.
8,573,459 B2	11/2013	Smith et al.	8,657,175 B2	2/2014	Sonnenschein et al.
8,573,461 B2	11/2013	Shelton, IV et al.	8,657,176 B2	2/2014	Shelton, IV et al.
8,573,462 B2	11/2013	Smith et al.	8,657,177 B2	2/2014	Scirica et al.
8,573,465 B2	11/2013	Shelton, IV	8,657,178 B2	2/2014	Hueil et al.
8,574,199 B2	11/2013	von Bulow et al.	8,657,482 B2	2/2014	Malackowski et al.
8,574,263 B2	11/2013	Mueller	8,657,808 B2	2/2014	McPherson et al.
8,575,880 B2	11/2013	Grantz	8,657,814 B2	2/2014	Werneth et al.
8,575,895 B2	11/2013	Garrastacho et al.	8,657,821 B2	2/2014	Palermo
8,579,176 B2	11/2013	Smith et al.	D701,238 S	3/2014	Lai et al.
8,579,178 B2	11/2013	Holsten et al.	8,662,370 B2	3/2014	Takei
8,579,897 B2	11/2013	Vakharia et al.	8,663,106 B2	3/2014	Stivoric et al.
8,579,937 B2	11/2013	Gresham	8,663,192 B2	3/2014	Hester et al.
8,584,919 B2	11/2013	Hueil et al.	8,663,245 B2	3/2014	Francischelli et al.
8,584,920 B2	11/2013	Hodgkinson	8,663,262 B2	3/2014	Smith et al.
8,584,921 B2	11/2013	Scirica	8,663,270 B2	3/2014	Donnigan et al.
8,585,583 B2	11/2013	Sakaguchi et al.	8,664,792 B2	3/2014	Rebsdorf
8,585,598 B2	11/2013	Razzaque et al.	8,668,129 B2	3/2014	Olson
8,585,721 B2	11/2013	Kirsch	8,668,130 B2	3/2014	Hess et al.
8,590,760 B2	11/2013	Cummins et al.	8,672,206 B2	3/2014	Aranyi et al.
8,590,762 B2	11/2013	Hess et al.	8,672,207 B2	3/2014	Shelton, IV et al.
8,590,764 B2	11/2013	Hartwick et al.	8,672,208 B2	3/2014	Hess et al.
8,591,400 B2	11/2013	Sugiyama	8,672,209 B2	3/2014	Crainich
8,596,515 B2	12/2013	Okoniewski	8,672,922 B2	3/2014	Loh et al.
8,597,745 B2	12/2013	Farnsworth et al.	8,672,935 B2	3/2014	Okada et al.
8,599,450 B2	12/2013	Kubo et al.	8,672,951 B2	3/2014	Smith et al.
8,602,125 B2	12/2013	King	8,673,210 B2	3/2014	Deshays
8,602,287 B2	12/2013	Yates et al.	8,675,820 B2	3/2014	Bale et al.
8,602,288 B2	12/2013	Shelton, IV et al.	8,678,263 B2	3/2014	Viola
8,603,077 B2	12/2013	Cooper et al.	8,678,994 B2	3/2014	Sonnenschein et al.
8,603,089 B2	12/2013	Viola	8,679,093 B2	3/2014	Farra
8,603,110 B2	12/2013	Maruyama et al.	8,679,098 B2	3/2014	Hart
8,603,135 B2	12/2013	Mueller	8,679,137 B2	3/2014	Bauman et al.
8,608,043 B2	12/2013	Scirica	8,679,154 B2	3/2014	Smith et al.
8,608,044 B2	12/2013	Hueil et al.	8,679,156 B2	3/2014	Smith et al.
8,608,045 B2	12/2013	Smith et al.	8,679,454 B2	3/2014	Guire et al.
8,608,046 B2	12/2013	Laurent et al.	8,684,248 B2	4/2014	Milliman
8,608,745 B2	12/2013	Guzman et al.	8,684,249 B2	4/2014	Racenet et al.
8,613,383 B2	12/2013	Beckman et al.	8,684,250 B2	4/2014	Bettuchi et al.
8,613,384 B2	12/2013	Pastorelli et al.	8,684,253 B2	4/2014	Giordano et al.
8,616,427 B2	12/2013	Viola	8,684,962 B2	4/2014	Kirschenman et al.
			8,685,004 B2	4/2014	Zemlock et al.
			8,685,020 B2	4/2014	Weizman et al.
			8,690,893 B2	4/2014	Deitch et al.
			8,695,866 B2	4/2014	Leimbach et al.

(56)

References Cited

U.S. PATENT DOCUMENTS

8,857,694 B2	10/2014	Shelton, IV et al.	8,956,342 B1	2/2015	Russo et al.
8,858,538 B2	10/2014	Belson et al.	8,956,390 B2	2/2015	Shah et al.
8,858,547 B2	10/2014	Brogna	8,958,860 B2	2/2015	Banerjee et al.
8,858,571 B2	10/2014	Shelton, IV et al.	8,960,519 B2	2/2015	Whitman et al.
8,858,590 B2	10/2014	Shelton, IV et al.	8,960,520 B2	2/2015	McCuen
8,864,007 B2	10/2014	Widenhouse et al.	8,960,521 B2	2/2015	Kostrzewski
8,864,009 B2	10/2014	Shelton, IV et al.	8,961,191 B2	2/2015	Hanshew
8,864,010 B2	10/2014	Williams	8,961,504 B2	2/2015	Hoarau et al.
8,864,750 B2	10/2014	Ross et al.	8,961,542 B2	2/2015	Whitfield et al.
8,869,912 B2	10/2014	Roßkamp et al.	8,963,714 B2	2/2015	Medhal et al.
8,869,913 B2	10/2014	Matthias et al.	D725,674 S	3/2015	Jung et al.
8,870,050 B2	10/2014	Hodgkinson	8,967,443 B2	3/2015	McCuen
8,870,867 B2	10/2014	Walberg et al.	8,967,444 B2	3/2015	Beetel
8,870,912 B2	10/2014	Brisson et al.	8,967,446 B2	3/2015	Beardsley et al.
8,875,971 B2	11/2014	Hall et al.	8,967,448 B2	3/2015	Carter et al.
8,875,972 B2	11/2014	Weisenburgh, II et al.	8,968,276 B2	3/2015	Zemlok et al.
8,876,698 B2	11/2014	Sakamoto et al.	8,968,308 B2	3/2015	Horner et al.
8,876,857 B2	11/2014	Burbank	8,968,312 B2	3/2015	Marczyk et al.
8,876,858 B2	11/2014	Braun	8,968,337 B2	3/2015	Whitfield et al.
8,882,660 B2	11/2014	Phee et al.	8,968,340 B2	3/2015	Chowaniec et al.
8,882,792 B2	11/2014	Dietz et al.	8,968,355 B2	3/2015	Malkowski et al.
8,884,560 B2	11/2014	Ito	8,968,358 B2	3/2015	Reschke
8,887,979 B2	11/2014	Mastri et al.	8,970,507 B2	3/2015	Holbein et al.
8,888,688 B2	11/2014	Julian et al.	8,973,803 B2	3/2015	Hall et al.
8,888,695 B2	11/2014	Piskun et al.	8,973,804 B2	3/2015	Hess et al.
8,888,792 B2	11/2014	Harris et al.	8,973,805 B2	3/2015	Scirica et al.
8,888,809 B2	11/2014	Davison et al.	8,974,440 B2	3/2015	Farritor et al.
8,893,946 B2	11/2014	Boudreaux et al.	8,974,542 B2	3/2015	Fujimoto et al.
8,893,949 B2	11/2014	Shelton, IV et al.	8,974,932 B2	3/2015	McGahan et al.
8,894,647 B2	11/2014	Beardsley et al.	8,978,954 B2	3/2015	Shelton, IV et al.
8,894,654 B2	11/2014	Anderson	8,978,955 B2	3/2015	Aronhalt et al.
8,899,460 B2	12/2014	Wojcicki	8,978,956 B2	3/2015	Schall et al.
8,899,461 B2	12/2014	Farascioni	8,979,843 B2	3/2015	Timm et al.
8,899,462 B2	12/2014	Kostrzewski et al.	8,979,890 B2	3/2015	Boudreaux
8,899,463 B2	12/2014	Schall et al.	8,982,195 B2	3/2015	Claus et al.
8,899,464 B2	12/2014	Hueil et al.	8,984,711 B2	3/2015	Ota et al.
8,899,465 B2	12/2014	Shelton, IV et al.	8,985,240 B2	3/2015	Winnard
8,899,466 B2	12/2014	Baxter, III et al.	8,985,429 B2	3/2015	Balek et al.
8,900,267 B2	12/2014	Woolfson et al.	8,986,302 B2	3/2015	Aldridge et al.
8,905,287 B2	12/2014	Racenet et al.	8,989,903 B2	3/2015	Weir et al.
8,905,977 B2	12/2014	Shelton et al.	8,991,676 B2	3/2015	Hess et al.
8,910,846 B2	12/2014	Viola	8,991,677 B2	3/2015	Moore et al.
8,910,847 B2	12/2014	Nalagatla et al.	8,991,678 B2	3/2015	Wellman et al.
8,911,426 B2	12/2014	Coppeta et al.	8,992,042 B2	3/2015	Eichenholz
8,911,448 B2	12/2014	Stein	8,992,422 B2	3/2015	Spivey et al.
8,911,460 B2	12/2014	Neurohr et al.	8,992,565 B2	3/2015	Brisson et al.
8,911,471 B2	12/2014	Spivey et al.	8,996,165 B2	3/2015	Wang et al.
8,912,746 B2	12/2014	Reid et al.	8,998,058 B2	4/2015	Moore et al.
8,915,842 B2	12/2014	Weisenburgh, II et al.	8,998,059 B2	4/2015	Smith et al.
8,920,368 B2	12/2014	Sandhu et al.	8,998,060 B2	4/2015	Bruewer et al.
8,920,433 B2	12/2014	Barrier et al.	8,998,061 B2	4/2015	Williams et al.
8,920,435 B2	12/2014	Smith et al.	8,998,939 B2	4/2015	Price et al.
8,920,438 B2	12/2014	Aranyi et al.	9,000,720 B2	4/2015	Stulen et al.
8,920,443 B2	12/2014	Hiles et al.	9,002,518 B2	4/2015	Manzo et al.
8,920,444 B2	12/2014	Hiles et al.	9,004,339 B1	4/2015	Park
8,922,163 B2	12/2014	Macdonald	9,004,799 B1	4/2015	Tibbits
8,925,782 B2	1/2015	Shelton, IV	9,005,230 B2	4/2015	Yates et al.
8,925,783 B2	1/2015	Zemlok et al.	9,005,238 B2	4/2015	DeSantis et al.
8,925,788 B2	1/2015	Hess et al.	9,005,243 B2	4/2015	Stopek et al.
8,926,506 B2	1/2015	Widenhouse et al.	9,010,606 B2	4/2015	Aranyi et al.
8,926,598 B2	1/2015	Mollere et al.	9,010,608 B2	4/2015	Casasanta, Jr. et al.
8,931,576 B2	1/2015	Iwata	9,010,611 B2	4/2015	Ross et al.
8,931,679 B2	1/2015	Kostrzewski	9,011,437 B2	4/2015	Woodruff et al.
8,931,680 B2	1/2015	Milliman	9,011,439 B2	4/2015	Shalaby et al.
8,931,682 B2	1/2015	Timm et al.	9,011,471 B2	4/2015	Timm et al.
8,931,692 B2	1/2015	Sancak	9,014,856 B2	4/2015	Manzo et al.
8,936,614 B2	1/2015	Allen, IV	9,016,539 B2	4/2015	Kostrzewski et al.
8,939,343 B2	1/2015	Milliman et al.	9,016,540 B2	4/2015	Whitman et al.
8,939,344 B2	1/2015	Olson et al.	9,016,541 B2	4/2015	Viola et al.
8,939,898 B2	1/2015	Omoto	9,016,542 B2	4/2015	Shelton, IV et al.
8,944,069 B2	2/2015	Miller et al.	9,016,545 B2	4/2015	Aranyi et al.
8,945,095 B2	2/2015	Blumenkranz et al.	9,017,331 B2	4/2015	Fox
8,945,098 B2	2/2015	Seibold et al.	9,017,355 B2	4/2015	Smith et al.
8,945,163 B2	2/2015	Voegele et al.	9,017,369 B2	4/2015	Renger et al.
8,955,732 B2	2/2015	Zemlok et al.	9,017,371 B2	4/2015	Whitman et al.
			9,017,849 B2	4/2015	Stulen et al.
			9,017,851 B2	4/2015	Felder et al.
			D729,274 S	5/2015	Clement et al.
			9,021,684 B2	5/2015	Lenker et al.

(56)

References Cited

U.S. PATENT DOCUMENTS

- | | | | | | |
|--------------|--------|---------------------|--------------|---------|--------------------------------|
| 9,023,014 B2 | 5/2015 | Chowaniec et al. | 9,101,358 B2 | 8/2015 | Kerr et al. |
| 9,023,069 B2 | 5/2015 | Kasvikis et al. | 9,101,359 B2 | 8/2015 | Smith et al. |
| 9,023,071 B2 | 5/2015 | Miller et al. | 9,101,385 B2 | 8/2015 | Shelton, IV et al. |
| 9,026,347 B2 | 5/2015 | Gadh et al. | 9,101,475 B2 | 8/2015 | Wei et al. |
| 9,027,817 B2 | 5/2015 | Milliman et al. | 9,101,621 B2 | 8/2015 | Zeldis |
| 9,028,468 B2 | 5/2015 | Scarfogliero et al. | 9,107,663 B2 | 8/2015 | Swensgard |
| 9,028,494 B2 | 5/2015 | Shelton, IV et al. | 9,107,667 B2 | 8/2015 | Hodgkinson |
| 9,028,495 B2 | 5/2015 | Mueller et al. | 9,107,690 B2 | 8/2015 | Bales, Jr. et al. |
| 9,028,510 B2 | 5/2015 | Miyamoto et al. | 9,110,587 B2 | 8/2015 | Kim et al. |
| 9,028,511 B2 | 5/2015 | Weller et al. | 9,113,862 B2 | 8/2015 | Morgan et al. |
| 9,028,519 B2 | 5/2015 | Yates et al. | 9,113,864 B2 | 8/2015 | Morgan et al. |
| 9,030,166 B2 | 5/2015 | Kano | 9,113,865 B2 | 8/2015 | Shelton, IV et al. |
| 9,030,169 B2 | 5/2015 | Christensen et al. | 9,113,868 B2 | 8/2015 | Felder et al. |
| 9,033,203 B2 | 5/2015 | Woodard, Jr. et al. | 9,113,873 B2 | 8/2015 | Marczyk et al. |
| 9,033,204 B2 | 5/2015 | Shelton, IV et al. | 9,113,874 B2 | 8/2015 | Shelton, IV et al. |
| 9,034,505 B2 | 5/2015 | Detry et al. | 9,113,875 B2 | 8/2015 | Viola et al. |
| 9,038,881 B1 | 5/2015 | Schaller et al. | 9,113,876 B2 | 8/2015 | Zemlok et al. |
| 9,039,690 B2 | 5/2015 | Kersten et al. | 9,113,879 B2 | 8/2015 | Felder et al. |
| 9,039,694 B2 | 5/2015 | Ross et al. | 9,113,880 B2 | 8/2015 | Zemlok et al. |
| 9,039,720 B2 | 5/2015 | Madan | 9,113,881 B2 | 8/2015 | Scirica |
| 9,040,062 B2 | 5/2015 | Maeda et al. | 9,113,883 B2 | 8/2015 | Aronhalt et al. |
| 9,043,027 B2 | 5/2015 | Durant et al. | 9,113,884 B2 | 8/2015 | Shelton, IV et al. |
| 9,044,227 B2 | 6/2015 | Shelton, IV et al. | 9,113,887 B2 | 8/2015 | Behnke, II et al. |
| 9,044,228 B2 | 6/2015 | Woodard, Jr. et al. | 9,119,615 B2 | 9/2015 | Felder et al. |
| 9,044,229 B2 | 6/2015 | Scheib et al. | 9,119,657 B2 | 9/2015 | Shelton, IV et al. |
| 9,044,230 B2 | 6/2015 | Morgan et al. | 9,119,898 B2 | 9/2015 | Bayon et al. |
| 9,044,238 B2 | 6/2015 | Orszulak | 9,119,957 B2 | 9/2015 | Gantz et al. |
| 9,044,241 B2 | 6/2015 | Barner et al. | 9,123,286 B2 | 9/2015 | Park |
| 9,044,261 B2 | 6/2015 | Houser | 9,124,097 B2 | 9/2015 | Cruz |
| 9,044,281 B2 | 6/2015 | Pool et al. | 9,125,651 B2 | 9/2015 | Mandakolathur Vasudevan et al. |
| 9,050,083 B2 | 6/2015 | Yates et al. | 9,125,654 B2 | 9/2015 | Aronhalt et al. |
| 9,050,084 B2 | 6/2015 | Schmid et al. | 9,125,662 B2 | 9/2015 | Shelton, IV |
| 9,050,089 B2 | 6/2015 | Orszulak | 9,126,317 B2 | 9/2015 | Lawton et al. |
| 9,050,100 B2 | 6/2015 | Yates et al. | 9,131,835 B2 | 9/2015 | Widenhouse et al. |
| 9,050,120 B2 | 6/2015 | Swarup et al. | 9,131,940 B2 | 9/2015 | Huitema et al. |
| 9,050,123 B2 | 6/2015 | Krause et al. | 9,131,950 B2 | 9/2015 | Matthew |
| 9,050,176 B2 | 6/2015 | Datta et al. | 9,131,957 B2 | 9/2015 | Skarbnik et al. |
| 9,050,192 B2 | 6/2015 | Mansmann | 9,138,225 B2 | 9/2015 | Huang et al. |
| 9,055,941 B2 | 6/2015 | Schmid et al. | 9,138,226 B2 | 9/2015 | Racenet et al. |
| 9,055,942 B2 | 6/2015 | Balbierz et al. | 9,144,455 B2 | 9/2015 | Kennedy et al. |
| 9,055,943 B2 | 6/2015 | Zemlok et al. | D740,414 S | 10/2015 | Katsura |
| 9,055,944 B2 | 6/2015 | Hodgkinson et al. | D741,882 S | 10/2015 | Shmilov et al. |
| 9,055,961 B2 | 6/2015 | Manzo et al. | 9,149,274 B2 | 10/2015 | Spivey et al. |
| 9,060,770 B2 | 6/2015 | Shelton, IV et al. | 9,149,324 B2 | 10/2015 | Huang et al. |
| 9,060,776 B2 | 6/2015 | Yates et al. | 9,149,325 B2 | 10/2015 | Worrell et al. |
| 9,060,794 B2 | 6/2015 | Kang et al. | 9,153,994 B2 | 10/2015 | Wood et al. |
| 9,060,894 B2 | 6/2015 | Wubbeling | 9,161,753 B2 | 10/2015 | Prior |
| 9,061,392 B2 | 6/2015 | Forgues et al. | 9,161,769 B2 | 10/2015 | Stoddard et al. |
| 9,070,068 B2 | 6/2015 | Coveley et al. | 9,161,803 B2 | 10/2015 | Yates et al. |
| 9,072,515 B2 | 7/2015 | Hall et al. | 9,161,807 B2 | 10/2015 | Garrison |
| 9,072,523 B2 | 7/2015 | Houser et al. | 9,161,855 B2 | 10/2015 | Rousseau et al. |
| 9,072,535 B2 | 7/2015 | Shelton, IV et al. | 9,164,271 B2 | 10/2015 | Ebata et al. |
| 9,072,536 B2 | 7/2015 | Shelton, IV et al. | 9,167,960 B2 | 10/2015 | Yamaguchi et al. |
| 9,078,653 B2 | 7/2015 | Leimbach et al. | 9,168,038 B2 | 10/2015 | Shelton, IV et al. |
| 9,078,654 B2 | 7/2015 | Whitman et al. | 9,168,039 B1 | 10/2015 | Knodel |
| 9,084,586 B2 | 7/2015 | Hafner et al. | 9,168,042 B2 | 10/2015 | Milliman |
| 9,084,601 B2 | 7/2015 | Moore et al. | 9,168,054 B2 | 10/2015 | Turner et al. |
| 9,084,602 B2 | 7/2015 | Gleiman | 9,168,144 B2 | 10/2015 | Rivin et al. |
| 9,086,875 B2 | 7/2015 | Harrat et al. | 9,171,244 B2 | 10/2015 | Endou et al. |
| 9,089,326 B2 | 7/2015 | Krumanaker et al. | 9,179,832 B2 | 11/2015 | Diolaiti |
| 9,089,330 B2 | 7/2015 | Widenhouse et al. | 9,179,911 B2 | 11/2015 | Morgan et al. |
| 9,089,338 B2 | 7/2015 | Smith et al. | 9,179,912 B2 | 11/2015 | Yates et al. |
| 9,089,352 B2 | 7/2015 | Jeong | 9,180,223 B2 | 11/2015 | Yu et al. |
| 9,089,360 B2 | 7/2015 | Messerly et al. | 9,182,244 B2 | 11/2015 | Luke et al. |
| 9,091,588 B2 | 7/2015 | Lefler | 9,186,046 B2 | 11/2015 | Ramamurthy et al. |
| D736,792 S | 8/2015 | Brinda et al. | 9,186,137 B2 | 11/2015 | Farascioni et al. |
| 9,095,339 B2 | 8/2015 | Moore et al. | 9,186,140 B2 | 11/2015 | Hiles et al. |
| 9,095,346 B2 | 8/2015 | Houser et al. | 9,186,142 B2 | 11/2015 | Fanelli et al. |
| 9,095,362 B2 | 8/2015 | Dachs, II et al. | 9,186,143 B2 | 11/2015 | Timm et al. |
| 9,095,367 B2 | 8/2015 | Olson et al. | 9,186,148 B2 | 11/2015 | Felder et al. |
| 9,096,033 B2 | 8/2015 | Holop et al. | 9,186,221 B2 | 11/2015 | Burbank |
| 9,098,153 B2 | 8/2015 | Shen et al. | 9,192,376 B2 | 11/2015 | Almodovar |
| 9,099,863 B2 | 8/2015 | Smith et al. | 9,192,380 B2 | 11/2015 | (Tarinelli) Racenet et al. |
| 9,099,877 B2 | 8/2015 | Banos et al. | 9,192,384 B2 | 11/2015 | Bettuchi |
| 9,099,922 B2 | 8/2015 | Toosky et al. | 9,192,430 B2 | 11/2015 | Rachlin et al. |
| | | | 9,192,434 B2 | 11/2015 | Twomey et al. |
| | | | 9,193,045 B2 | 11/2015 | Saur et al. |
| | | | 9,197,079 B2 | 11/2015 | Yip et al. |
| | | | D744,528 S | 12/2015 | Agrawal |

(56)

References Cited

U.S. PATENT DOCUMENTS

D746,459 S	12/2015	Kaercher et al.	9,274,095 B2	3/2016	Humayun et al.
9,198,642 B2	12/2015	Storz	9,277,919 B2	3/2016	Timmer et al.
9,198,644 B2	12/2015	Balek et al.	9,277,922 B2	3/2016	Carter et al.
9,198,661 B2	12/2015	Swensgard	9,277,969 B2	3/2016	Brannan et al.
9,198,662 B2	12/2015	Barton et al.	9,282,962 B2	3/2016	Schmid et al.
9,198,683 B2	12/2015	Friedman et al.	9,282,963 B2	3/2016	Bryant
9,204,830 B2	12/2015	Zand et al.	9,282,966 B2	3/2016	Shelton, IV et al.
9,204,877 B2	12/2015	Whitman et al.	9,282,974 B2	3/2016	Shelton, IV
9,204,878 B2	12/2015	Hall et al.	9,283,028 B2	3/2016	Johnson
9,204,879 B2	12/2015	Shelton, IV	9,283,045 B2	3/2016	Rhee et al.
9,204,880 B2	12/2015	Baxter, III et al.	9,283,054 B2	3/2016	Morgan et al.
9,204,881 B2	12/2015	Penna	9,289,206 B2	3/2016	Hess et al.
9,204,923 B2	12/2015	Manzo et al.	9,289,207 B2	3/2016	Shelton, IV
9,204,924 B2	12/2015	Marczyk et al.	9,289,210 B2	3/2016	Baxter, III et al.
9,211,120 B2	12/2015	Scheib et al.	9,289,211 B2	3/2016	Williams et al.
9,211,121 B2	12/2015	Hall et al.	9,289,212 B2	3/2016	Shelton, IV et al.
9,211,122 B2	12/2015	Hagerty et al.	9,289,225 B2	3/2016	Shelton, IV et al.
9,216,013 B2	12/2015	Scirica et al.	9,289,256 B2	3/2016	Shelton, IV et al.
9,216,019 B2	12/2015	Schmid et al.	9,293,757 B2	3/2016	Toussaint et al.
9,216,020 B2	12/2015	Zhang et al.	9,295,464 B2	3/2016	Shelton, IV et al.
9,216,030 B2	12/2015	Fan et al.	9,295,465 B2	3/2016	Farascioni
9,216,062 B2	12/2015	Duque et al.	9,295,466 B2	3/2016	Hodgkinson et al.
9,220,500 B2	12/2015	Swayze et al.	9,295,467 B2	3/2016	Scirica
9,220,501 B2	12/2015	Baxter, III et al.	9,295,468 B2	3/2016	Heinrich et al.
9,220,502 B2	12/2015	Zemlok et al.	9,295,514 B2	3/2016	Shelton, IV et al.
9,220,504 B2	12/2015	Viola et al.	9,295,522 B2	3/2016	Kostrzewski
9,220,508 B2	12/2015	Dannaher	9,295,565 B2	3/2016	McLean
9,220,559 B2	12/2015	Worrell et al.	9,295,784 B2	3/2016	Eggert et al.
9,220,570 B2	12/2015	Kim et al.	D753,167 S	4/2016	Yu et al.
D746,854 S	1/2016	Shardlow et al.	9,301,691 B2	4/2016	Hufnagel et al.
9,226,750 B2	1/2016	Weir et al.	9,301,752 B2	4/2016	Mandakolathur Vasudevan et al.
9,226,751 B2	1/2016	Shelton, IV et al.	9,301,753 B2	4/2016	Aldridge et al.
9,226,754 B2	1/2016	D'Agostino et al.	9,301,755 B2	4/2016	Shelton, IV et al.
9,226,760 B2	1/2016	Shelton, IV	9,301,759 B2	4/2016	Spivey et al.
9,226,761 B2	1/2016	Burbank	9,301,811 B2	4/2016	Goldberg et al.
9,226,767 B2	1/2016	Stulen et al.	9,307,965 B2	4/2016	Ming et al.
9,226,799 B2	1/2016	Lightcap et al.	9,307,986 B2	4/2016	Hall et al.
9,232,941 B2	1/2016	Mandakolathur Vasudevan et al.	9,307,987 B2	4/2016	Swensgard et al.
9,232,945 B2	1/2016	Zingman	9,307,988 B2	4/2016	Shelton, IV
9,232,979 B2	1/2016	Parihar et al.	9,307,989 B2	4/2016	Shelton, IV et al.
9,233,610 B2	1/2016	Kim et al.	9,307,994 B2	4/2016	Gresham et al.
9,237,891 B2	1/2016	Shelton, IV	9,308,009 B2	4/2016	Madan et al.
9,237,892 B2	1/2016	Hodgkinson	9,308,011 B2	4/2016	Chao et al.
9,237,895 B2	1/2016	McCarthy et al.	9,308,646 B2	4/2016	Lim et al.
9,237,900 B2	1/2016	Boudreaux et al.	9,313,915 B2	4/2016	Niu et al.
9,237,921 B2	1/2016	Messerly et al.	9,314,246 B2	4/2016	Shelton, IV et al.
9,239,064 B2	1/2016	Helbig et al.	9,314,247 B2	4/2016	Shelton, IV et al.
9,240,740 B2	1/2016	Zeng et al.	9,314,261 B2	4/2016	Bales, Jr. et al.
9,241,711 B2	1/2016	Ivanko	9,314,291 B2	4/2016	Schall et al.
9,241,712 B2	1/2016	Zemlok et al.	9,314,339 B2	4/2016	Mansmann
9,241,714 B2	1/2016	Timm et al.	9,314,908 B2	4/2016	Tanimoto et al.
9,241,716 B2	1/2016	Whitman	9,320,518 B2	4/2016	Henderson et al.
9,241,731 B2	1/2016	Boudreaux et al.	9,320,520 B2	4/2016	Shelton, IV et al.
9,241,758 B2	1/2016	Franer et al.	9,320,521 B2	4/2016	Shelton, IV et al.
9,244,524 B2	1/2016	Inoue et al.	9,320,523 B2	4/2016	Shelton, IV et al.
D748,668 S	2/2016	Kim et al.	9,325,516 B2	4/2016	Pera et al.
D749,128 S	2/2016	Perez et al.	D755,196 S	5/2016	Meyers et al.
D749,623 S	2/2016	Gray et al.	D756,373 S	5/2016	Raskin et al.
D750,122 S	2/2016	Shardlow et al.	D756,377 S	5/2016	Connolly et al.
D750,129 S	2/2016	Kwon	D757,028 S	5/2016	Goldenberg et al.
9,254,131 B2	2/2016	Soltz et al.	9,326,767 B2	5/2016	Koch et al.
9,254,170 B2	2/2016	Parihar et al.	9,326,768 B2	5/2016	Shelton, IV
9,259,265 B2	2/2016	Harris et al.	9,326,769 B2	5/2016	Shelton, IV et al.
9,259,274 B2	2/2016	Prisco	9,326,770 B2	5/2016	Shelton, IV et al.
9,259,275 B2	2/2016	Burbank	9,326,771 B2	5/2016	Baxter, III et al.
9,261,172 B2	2/2016	Solomon et al.	9,326,788 B2	5/2016	Batross et al.
9,265,500 B2	2/2016	Sorrentino et al.	9,326,812 B2	5/2016	Waler et al.
9,265,510 B2	2/2016	Dietzel et al.	9,326,824 B2	5/2016	Inoue et al.
9,265,516 B2	2/2016	Casey et al.	9,327,061 B2	5/2016	Govil et al.
9,265,585 B2	2/2016	Wingardner et al.	9,331,721 B2	5/2016	Martinez Nuevo et al.
9,271,718 B2	3/2016	Milad et al.	9,332,890 B2	5/2016	Ozawa
9,271,727 B2	3/2016	McGuckin, Jr. et al.	9,332,974 B2	5/2016	Henderson et al.
9,271,753 B2	3/2016	Butler et al.	9,332,984 B2	5/2016	Weaner et al.
9,271,799 B2	3/2016	Shelton, IV et al.	9,332,987 B2	5/2016	Leimbach et al.
9,272,406 B2	3/2016	Aronhalt et al.	9,333,040 B2	5/2016	Shellenberger et al.
			9,333,082 B2	5/2016	Wei et al.
			9,337,668 B2	5/2016	Yip
			9,339,226 B2	5/2016	van der Walt et al.
			9,339,342 B2	5/2016	Prisco et al.

(56)

References Cited

U.S. PATENT DOCUMENTS

9,345,477 B2	5/2016	Anim et al.	9,411,370 B2	8/2016	Benni et al.
9,345,479 B2	5/2016	(Tarinelli) Racenet et al.	9,413,128 B2	8/2016	Tien et al.
9,345,480 B2	5/2016	Hessler et al.	9,414,838 B2	8/2016	Shelton, IV et al.
9,345,481 B2	5/2016	Hall et al.	9,414,849 B2	8/2016	Nagashimada
9,345,503 B2	5/2016	Ishida et al.	9,414,880 B2	8/2016	Monson et al.
9,351,726 B2	5/2016	Leimbach et al.	9,420,967 B2	8/2016	Zand et al.
9,351,727 B2	5/2016	Leimbach et al.	9,421,003 B2	8/2016	Williams et al.
9,351,728 B2	5/2016	Sniffin et al.	9,421,014 B2	8/2016	Ingmanson et al.
9,351,730 B2	5/2016	Schmid et al.	9,421,030 B2	8/2016	Cole et al.
9,351,731 B2	5/2016	Carter et al.	9,421,060 B2	8/2016	Monson et al.
9,351,732 B2	5/2016	Hodgkinson	9,421,062 B2	8/2016	Houser et al.
9,352,071 B2	5/2016	Landgrebe et al.	9,421,682 B2	8/2016	McClaskey et al.
D758,433 S	6/2016	Lee et al.	9,427,223 B2	8/2016	Park et al.
D759,063 S	6/2016	Chen	9,427,231 B2	8/2016	Racenet et al.
9,358,003 B2	6/2016	Hall et al.	9,429,204 B2	8/2016	Stefan et al.
9,358,004 B2	6/2016	Sniffin et al.	D767,624 S	9/2016	Lee et al.
9,358,005 B2	6/2016	Shelton, IV et al.	9,433,411 B2	9/2016	Racenet et al.
9,358,015 B2	6/2016	Sorrentino et al.	9,433,414 B2	9/2016	Chen et al.
9,358,031 B2	6/2016	Manzo	9,433,419 B2	9/2016	Gonzalez et al.
9,358,065 B2	6/2016	Ladtchow et al.	9,433,420 B2	9/2016	Hodgkinson
9,364,217 B2	6/2016	Kostrzewski et al.	9,439,649 B2	9/2016	Shelton, IV et al.
9,364,219 B2	6/2016	Olson et al.	9,439,650 B2	9/2016	McGuckin, Jr. et al.
9,364,220 B2	6/2016	Williams	9,439,651 B2	9/2016	Smith et al.
9,364,223 B2	6/2016	Scirica	9,439,668 B2	9/2016	Timm et al.
9,364,226 B2	6/2016	Zemlok et al.	9,445,808 B2	9/2016	Woodard, Jr. et al.
9,364,228 B2	6/2016	Straehnz et al.	9,445,813 B2	9/2016	Shelton, IV et al.
9,364,229 B2	6/2016	D'Agostino et al.	9,445,816 B2	9/2016	Swayze et al.
9,364,230 B2	6/2016	Shelton, IV et al.	9,445,817 B2	9/2016	Bettuchi
9,364,231 B2	6/2016	Wenchell	9,446,226 B2	9/2016	Zilberman
9,364,233 B2	6/2016	Alexander, III et al.	9,451,938 B2	9/2016	Res et al.
9,364,279 B2	6/2016	Houser et al.	9,451,958 B2	9/2016	Shelton, IV et al.
9,368,991 B2	6/2016	Qahouq	D768,152 S	10/2016	Gutierrez et al.
9,370,341 B2	6/2016	Ceniccola et al.	D768,156 S	10/2016	Frincke
9,370,358 B2	6/2016	Shelton, IV et al.	D768,167 S	10/2016	Jones et al.
9,370,361 B2	6/2016	Viola et al.	D769,315 S	10/2016	Scotti
9,370,362 B2	6/2016	Petty et al.	D769,930 S	10/2016	Agrawal
9,370,364 B2	6/2016	Smith et al.	9,461,340 B2	10/2016	Li et al.
9,370,400 B2	6/2016	Parihar	9,463,012 B2	10/2016	Bonutti et al.
9,375,206 B2	6/2016	Vidal et al.	9,463,040 B2	10/2016	Jeong et al.
9,375,218 B2	6/2016	Wheeler et al.	9,463,260 B2	10/2016	Stopek
9,375,230 B2	6/2016	Ross et al.	9,468,438 B2	10/2016	Baber et al.
9,375,232 B2	6/2016	Hunt et al.	9,468,447 B2	10/2016	Aman et al.
9,375,255 B2	6/2016	Houser et al.	9,470,297 B2	10/2016	Aranyi et al.
D761,309 S	7/2016	Lee et al.	9,471,969 B2	10/2016	Zeng et al.
9,381,058 B2	7/2016	Houser et al.	9,474,506 B2	10/2016	Magnin et al.
9,383,881 B2	7/2016	Day et al.	9,474,513 B2	10/2016	Ishida et al.
9,385,640 B2	7/2016	Sun et al.	9,474,523 B2	10/2016	Meade et al.
9,386,983 B2	7/2016	Swensgard et al.	9,474,540 B2	10/2016	Stokes et al.
9,386,984 B2	7/2016	Aronhalt et al.	9,475,180 B2	10/2016	Eshleman et al.
9,386,985 B2	7/2016	Koch, Jr. et al.	D770,476 S	11/2016	Jitkoff et al.
9,386,988 B2	7/2016	Baxter, III et al.	D770,515 S	11/2016	Cho et al.
9,387,003 B2	7/2016	Kaercher et al.	D771,116 S	11/2016	Dellinger et al.
9,392,885 B2	7/2016	Vogler et al.	D772,905 S	11/2016	Ingenlath
9,393,015 B2	7/2016	Laurent et al.	9,480,476 B2	11/2016	Aldridge et al.
9,393,017 B2	7/2016	Flanagan et al.	9,480,492 B2	11/2016	Aranyi et al.
9,393,018 B2	7/2016	Wang et al.	9,483,095 B2	11/2016	Tran et al.
9,393,354 B2	7/2016	Freedman et al.	9,486,186 B2	11/2016	Fiebig et al.
9,396,369 B1	7/2016	Whitehurst et al.	9,486,213 B2	11/2016	Altman et al.
9,396,669 B2	7/2016	Karkanias et al.	9,486,214 B2	11/2016	Shelton, IV
9,398,905 B2	7/2016	Martin	9,486,215 B2	11/2016	Olson et al.
9,398,911 B2	7/2016	Auld	9,486,302 B2	11/2016	Boey et al.
D763,277 S	8/2016	Ahmed et al.	9,488,197 B2	11/2016	Wi
D764,498 S	8/2016	Capela et al.	9,492,146 B2	11/2016	Kostrzewski et al.
9,402,604 B2	8/2016	Williams et al.	9,492,167 B2	11/2016	Shelton, IV et al.
9,402,625 B2	8/2016	Coleman et al.	9,492,170 B2	11/2016	Bear et al.
9,402,626 B2	8/2016	Ortiz et al.	9,492,172 B2	11/2016	Weisshaupt et al.
9,402,627 B2	8/2016	Stevenson et al.	9,492,189 B2	11/2016	Williams et al.
9,402,629 B2	8/2016	Ehrenfels et al.	9,492,192 B2	11/2016	To et al.
9,402,679 B2	8/2016	Ginnebaugh et al.	9,492,237 B2	11/2016	Kang et al.
9,402,682 B2	8/2016	Worrell et al.	9,498,213 B2	11/2016	Marczyk et al.
9,402,688 B2	8/2016	Min et al.	9,498,219 B2	11/2016	Moore et al.
9,408,604 B2	8/2016	Shelton, IV et al.	9,498,231 B2	11/2016	Haider et al.
9,408,605 B1	8/2016	Knodel et al.	9,504,455 B2	11/2016	Whitman et al.
9,408,606 B2	8/2016	Shelton, IV	9,504,483 B2	11/2016	Houser et al.
9,408,622 B2	8/2016	Stulen et al.	9,504,520 B2	11/2016	Worrell et al.
			9,504,521 B2	11/2016	Deutmeyer et al.
			9,504,528 B2	11/2016	Ivinson et al.
			9,507,399 B2	11/2016	Chien
			D774,547 S	12/2016	Capela et al.

(56)

References Cited

U.S. PATENT DOCUMENTS

9,687,232 B2	6/2017	Shelton, IV et al.	9,757,126 B2	9/2017	Cappola
9,687,233 B2	6/2017	Fernandez et al.	9,757,128 B2	9/2017	Baber et al.
9,687,236 B2	6/2017	Leimbach et al.	9,757,129 B2	9/2017	Williams
9,687,237 B2	6/2017	Schmid et al.	9,757,130 B2	9/2017	Shelton, IV
9,687,253 B2	6/2017	Detry et al.	9,763,662 B2	9/2017	Shelton, IV et al.
9,689,466 B2	6/2017	Kanai et al.	9,763,668 B2	9/2017	Whitfield et al.
9,690,362 B2	6/2017	Leimbach et al.	9,770,245 B2	9/2017	Swayze et al.
9,693,772 B2	7/2017	Ingmanson et al.	9,770,274 B2	9/2017	Pool et al.
9,693,774 B2	7/2017	Gettinger et al.	D798,886 S	10/2017	Prophete et al.
9,693,775 B2	7/2017	Agarwal et al.	D800,742 S	10/2017	Rhodes
9,693,777 B2	7/2017	Schellin et al.	D800,744 S	10/2017	Jitkoff et al.
9,700,309 B2	7/2017	Jaworek et al.	D800,766 S	10/2017	Park et al.
9,700,310 B2	7/2017	Morgan et al.	D800,904 S	10/2017	Leimbach et al.
9,700,312 B2	7/2017	Kostrzewski et al.	9,775,608 B2	10/2017	Aronhalt et al.
9,700,314 B2	7/2017	Marczyk	9,775,609 B2	10/2017	Shelton, IV et al.
9,700,315 B2	7/2017	Chen et al.	9,775,610 B2	10/2017	Nicholas et al.
9,700,317 B2	7/2017	Aronhalt et al.	9,775,611 B2	10/2017	Kostrzewski
9,700,318 B2	7/2017	Scirica et al.	9,775,613 B2	10/2017	Shelton, IV et al.
9,700,319 B2	7/2017	Motooka et al.	9,775,614 B2	10/2017	Shelton, IV et al.
9,700,320 B2	7/2017	Dinando et al.	9,775,618 B2	10/2017	Bettuchi et al.
9,700,321 B2	7/2017	Shelton, IV et al.	9,775,635 B2	10/2017	Takei
9,700,334 B2	7/2017	Hinman et al.	9,775,678 B2	10/2017	Lohmeier
9,702,823 B2	7/2017	Maher et al.	9,782,169 B2	10/2017	Kimsey et al.
9,706,674 B2	7/2017	Collins et al.	9,782,170 B2	10/2017	Zemlok et al.
9,706,981 B2	7/2017	Nicholas et al.	9,782,180 B2	10/2017	Smith et al.
9,706,991 B2	7/2017	Hess et al.	9,782,187 B2	10/2017	Zergiebel et al.
9,706,993 B2	7/2017	Hessler et al.	9,782,193 B2	10/2017	Thistle
9,707,003 B2	7/2017	Hoell, Jr. et al.	9,782,214 B2	10/2017	Houser et al.
9,707,005 B2	7/2017	Strobl et al.	9,788,834 B2	10/2017	Schmid et al.
9,707,026 B2	7/2017	Malackowski et al.	9,788,835 B2	10/2017	Morgan et al.
9,707,033 B2	7/2017	Parihar et al.	9,788,836 B2	10/2017	Overmyer et al.
9,707,043 B2	7/2017	Bozung	9,788,847 B2	10/2017	Jinno
9,707,684 B2	7/2017	Ruiz Morales et al.	9,788,851 B2	10/2017	Dannaher et al.
9,713,468 B2	7/2017	Harris et al.	9,788,902 B2	10/2017	Inoue et al.
9,713,470 B2	7/2017	Scirica et al.	9,795,379 B2	10/2017	Leimbach et al.
9,713,474 B2	7/2017	Lorenz	9,795,380 B2	10/2017	Shelton, IV et al.
D795,919 S	8/2017	Bischoff et al.	9,795,381 B2	10/2017	Shelton, IV
9,717,497 B2	8/2017	Zerkle et al.	9,795,382 B2	10/2017	Shelton, IV
9,717,498 B2	8/2017	Aranyi et al.	9,795,383 B2	10/2017	Aldridge et al.
9,718,190 B2	8/2017	Larkin et al.	9,795,384 B2	10/2017	Weaner et al.
9,722,236 B2	8/2017	Sathrum	9,797,486 B2	10/2017	Zergiebel et al.
9,724,091 B2	8/2017	Shelton, IV et al.	9,801,626 B2	10/2017	Parihar et al.
9,724,092 B2	8/2017	Baxter, III et al.	9,801,627 B2	10/2017	Harris et al.
9,724,094 B2	8/2017	Baber et al.	9,801,628 B2	10/2017	Harris et al.
9,724,095 B2	8/2017	Gupta et al.	9,801,634 B2	10/2017	Shelton, IV et al.
9,724,096 B2	8/2017	Thompson et al.	9,802,033 B2	10/2017	Hibner et al.
9,724,098 B2	8/2017	Baxter, III et al.	9,804,618 B2	10/2017	Leimbach et al.
9,724,118 B2	8/2017	Schulte et al.	D803,234 S	11/2017	Day et al.
9,724,163 B2	8/2017	Orban	D803,235 S	11/2017	Markson et al.
9,730,692 B2	8/2017	Shelton, IV et al.	D803,850 S	11/2017	Chang et al.
9,730,695 B2	8/2017	Leimbach et al.	9,808,244 B2	11/2017	Leimbach et al.
9,730,697 B2	8/2017	Morgan et al.	9,808,246 B2	11/2017	Shelton, IV et al.
9,730,717 B2	8/2017	Katsuki et al.	9,808,247 B2	11/2017	Shelton, IV et al.
9,730,757 B2	8/2017	Brudniok	9,808,248 B2	11/2017	Hoffman
9,731,410 B2	8/2017	Hirabayashi et al.	9,808,249 B2	11/2017	Shelton, IV
9,733,663 B2	8/2017	Leimbach et al.	9,814,460 B2	11/2017	Kimsey et al.
9,737,297 B2	8/2017	Racenet et al.	9,814,462 B2	11/2017	Woodard, Jr. et al.
9,737,298 B2	8/2017	Isbell, Jr.	9,814,463 B2	11/2017	Williams et al.
9,737,299 B2	8/2017	Yan	9,814,530 B2	11/2017	Weir et al.
9,737,301 B2	8/2017	Baber et al.	9,814,561 B2	11/2017	Forsell
9,737,302 B2	8/2017	Shelton, IV et al.	9,815,118 B1	11/2017	Schmitt et al.
9,737,303 B2	8/2017	Shelton, IV et al.	9,820,445 B2	11/2017	Simpson et al.
9,737,365 B2	8/2017	Hegeman et al.	9,820,737 B2	11/2017	Beardsley et al.
9,743,927 B2	8/2017	Whitman	9,820,738 B2	11/2017	Lytte, IV et al.
9,743,928 B2	8/2017	Shelton, IV et al.	9,820,741 B2	11/2017	Kostrzewski
9,743,929 B2	8/2017	Leimbach et al.	9,820,768 B2	11/2017	Gee et al.
D798,319 S	9/2017	Bergstrand et al.	9,825,455 B2	11/2017	Sandhu et al.
9,750,498 B2	9/2017	Timm et al.	9,826,976 B2	11/2017	Parihar et al.
9,750,499 B2	9/2017	Leimbach et al.	9,826,977 B2	11/2017	Leimbach et al.
9,750,501 B2	9/2017	Shelton, IV et al.	9,826,978 B2	11/2017	Shelton, IV et al.
9,750,502 B2	9/2017	Scirica et al.	9,829,698 B2	11/2017	Haraguchi et al.
9,750,503 B2	9/2017	Milliman	D806,108 S	12/2017	Day
9,750,639 B2	9/2017	Barnes et al.	9,833,235 B2	12/2017	Penna et al.
9,757,123 B2	9/2017	Giordano et al.	9,833,236 B2	12/2017	Shelton, IV et al.
9,757,124 B2	9/2017	Schellin et al.	9,833,238 B2	12/2017	Baxter, III et al.
			9,833,239 B2	12/2017	Yates et al.
			9,833,241 B2	12/2017	Huitema et al.
			9,833,242 B2	12/2017	Baxter, III et al.
			9,839,420 B2	12/2017	Shelton, IV et al.

(56)

References Cited

U.S. PATENT DOCUMENTS

9,839,421 B2	12/2017	Zerkle et al.	9,913,644 B2	3/2018	McCuen
9,839,422 B2	12/2017	Schellin et al.	9,913,646 B2	3/2018	Shelton, IV
9,839,423 B2	12/2017	Vendely et al.	9,913,647 B2	3/2018	Weisenburgh, II et al.
9,839,427 B2	12/2017	Swayze et al.	9,913,648 B2	3/2018	Shelton, IV et al.
9,839,428 B2	12/2017	Baxter, III et al.	9,913,694 B2	3/2018	Brisson
9,839,429 B2	12/2017	Weisenburgh, II et al.	9,913,733 B2	3/2018	Piron et al.
9,839,480 B2	12/2017	Pribanic et al.	9,918,704 B2	3/2018	Shelton, IV et al.
9,839,481 B2	12/2017	Blumenkranz et al.	9,918,714 B2	3/2018	Gibbons, Jr.
9,844,368 B2	12/2017	Boudreaux et al.	9,918,715 B2	3/2018	Menn
9,844,369 B2	12/2017	Huitema et al.	9,918,716 B2	3/2018	Baxter, III et al.
9,844,372 B2	12/2017	Shelton, IV et al.	9,918,717 B2	3/2018	Czernik
9,844,373 B2	12/2017	Swayze et al.	9,918,730 B2	3/2018	Trees et al.
9,844,374 B2	12/2017	Lytle, IV et al.	9,924,941 B2	3/2018	Burbank
9,844,375 B2	12/2017	Overmyer et al.	9,924,942 B2	3/2018	Swayze et al.
9,844,376 B2	12/2017	Baxter, III et al.	9,924,943 B2	3/2018	Mohan Pinjala et al.
9,844,379 B2	12/2017	Shelton, IV et al.	9,924,945 B2	3/2018	Zheng et al.
9,848,871 B2	12/2017	Harris et al.	9,924,946 B2	3/2018	Vendely et al.
9,848,873 B2	12/2017	Shelton, IV	9,924,947 B2	3/2018	Shelton, IV et al.
9,848,875 B2	12/2017	Aronhalt et al.	9,924,961 B2	3/2018	Shelton, IV et al.
9,848,877 B2	12/2017	Shelton, IV et al.	9,931,106 B2	4/2018	Au et al.
9,850,994 B2	12/2017	Schena	9,931,116 B2	4/2018	Racenet et al.
D808,989 S	1/2018	Ayvazian et al.	9,931,117 B2	4/2018	Hathaway et al.
9,855,039 B2	1/2018	Racenet et al.	9,931,118 B2	4/2018	Shelton, IV et al.
9,855,040 B2	1/2018	Kostrzewski	9,931,120 B2	4/2018	Chen et al.
9,855,662 B2	1/2018	Ruiz Morales et al.	9,936,949 B2	4/2018	Measamer et al.
9,861,261 B2	1/2018	Shahinian	9,936,950 B2	4/2018	Shelton, IV et al.
9,861,359 B2	1/2018	Shelton, IV et al.	9,936,951 B2	4/2018	Hufnagel et al.
9,861,361 B2	1/2018	Aronhalt et al.	9,936,952 B2	4/2018	Demmy
9,861,362 B2	1/2018	Whitman et al.	9,936,954 B2	4/2018	Shelton, IV et al.
9,861,366 B2	1/2018	Aranyi	9,937,626 B2	4/2018	Rockrohr
9,861,382 B2	1/2018	Smith et al.	9,943,309 B2	4/2018	Shelton, IV et al.
9,861,446 B2	1/2018	Lang	9,943,310 B2	4/2018	Harris et al.
9,867,612 B2	1/2018	Parihar et al.	9,943,312 B2	4/2018	Posada et al.
9,867,613 B2	1/2018	Marczyk et al.	9,949,754 B2	4/2018	Newhauser et al.
9,867,615 B2	1/2018	Fanelli et al.	9,953,193 B2	4/2018	Butler et al.
9,867,617 B2	1/2018	Ma	D819,072 S	5/2018	Clediere
9,867,618 B2	1/2018	Hall et al.	9,955,954 B2	5/2018	Destoumieux et al.
9,867,620 B2	1/2018	Fischvogt et al.	9,955,965 B2	5/2018	Chen et al.
9,868,198 B2	1/2018	Nicholas et al.	9,955,966 B2	5/2018	Zergiebel
9,872,682 B2	1/2018	Hess et al.	9,956,677 B2	5/2018	Baskar et al.
9,872,684 B2	1/2018	Hall et al.	9,962,129 B2	5/2018	Jerebko et al.
9,872,722 B2	1/2018	Lech	9,962,157 B2	5/2018	Sapre
9,877,721 B2	1/2018	Schellin et al.	9,962,158 B2	5/2018	Hall et al.
9,877,722 B2	1/2018	Schellin et al.	9,962,159 B2	5/2018	Heinrich et al.
9,877,723 B2	1/2018	Hall et al.	9,962,161 B2	5/2018	Scheib et al.
9,877,776 B2	1/2018	Boudreaux	9,968,354 B2	5/2018	Shelton, IV et al.
D810,099 S	2/2018	Riedel	9,968,355 B2	5/2018	Shelton, IV et al.
9,883,843 B2	2/2018	Garlow	9,968,356 B2	5/2018	Shelton, IV et al.
9,883,860 B2	2/2018	Leimbach	9,968,397 B2	5/2018	Taylor et al.
9,883,861 B2	2/2018	Shelton, IV et al.	9,974,529 B2	5/2018	Shelton, IV et al.
9,884,456 B2	2/2018	Schellin et al.	9,974,538 B2	5/2018	Baxter, III et al.
9,888,914 B2	2/2018	Martin et al.	9,974,539 B2	5/2018	Yates et al.
9,888,919 B2	2/2018	Leimbach et al.	9,974,541 B2	5/2018	Calderoni
9,888,921 B2	2/2018	Williams et al.	9,974,542 B2	5/2018	Hodgkinson
9,888,924 B2	2/2018	Ebersole et al.	9,980,713 B2	5/2018	Aronhalt et al.
9,889,230 B2	2/2018	Bennett et al.	9,980,724 B2	5/2018	Farascioni et al.
9,895,147 B2	2/2018	Shelton, IV	9,980,729 B2	5/2018	Moore et al.
9,895,148 B2	2/2018	Shelton, IV et al.	9,980,769 B2	5/2018	Trees et al.
9,895,813 B2	2/2018	Blumenkranz et al.	D819,680 S	6/2018	Nguyen
9,901,339 B2	2/2018	Farascioni	D819,682 S	6/2018	Howard et al.
9,901,341 B2	2/2018	Kostrzewski	D819,684 S	6/2018	Dart
9,901,342 B2	2/2018	Shelton, IV et al.	D820,307 S	6/2018	Jian et al.
9,901,344 B2	2/2018	Moore et al.	D820,867 S	6/2018	Dickens et al.
9,901,345 B2	2/2018	Moore et al.	9,987,000 B2	6/2018	Shelton, IV et al.
9,901,346 B2	2/2018	Moore et al.	9,987,003 B2	6/2018	Timm et al.
9,901,406 B2	2/2018	State et al.	9,987,006 B2	6/2018	Morgan et al.
9,901,412 B2	2/2018	Lathrop et al.	9,987,008 B2	6/2018	Scirica et al.
D813,899 S	3/2018	Erant et al.	9,987,095 B2	6/2018	Chowaniec et al.
9,907,456 B2	3/2018	Miyoshi	9,987,097 B2	6/2018	van der Weide et al.
9,907,552 B2	3/2018	Measamer et al.	9,987,099 B2	6/2018	Chen et al.
9,907,553 B2	3/2018	Cole et al.	9,993,248 B2	6/2018	Shelton, IV et al.
9,907,600 B2	3/2018	Stulen et al.	9,993,258 B2	6/2018	Shelton, IV et al.
9,907,620 B2	3/2018	Shelton, IV et al.	9,993,284 B2	6/2018	Boudreaux
9,913,641 B2	3/2018	Takemoto et al.	9,999,408 B2	6/2018	Boudreaux et al.
9,913,642 B2	3/2018	Leimbach et al.	9,999,423 B2	6/2018	Schuckmann et al.
			9,999,426 B2	6/2018	Moore et al.
			9,999,431 B2	6/2018	Shelton, IV et al.
			9,999,472 B2	6/2018	Weir et al.
			10,004,497 B2	6/2018	Overmyer et al.

(56)

References Cited

U.S. PATENT DOCUMENTS

10,004,498 B2	6/2018	Morgan et al.	10,085,751 B2	10/2018	Overmyer et al.
10,004,500 B2	6/2018	Shelton, IV et al.	10,085,754 B2	10/2018	Sniffin et al.
10,004,501 B2	6/2018	Shelton, IV et al.	10,085,806 B2	10/2018	Hagn et al.
10,004,505 B2	6/2018	Moore et al.	10,092,290 B2	10/2018	Yigit et al.
10,004,506 B2	6/2018	Shelton, IV et al.	10,092,292 B2	10/2018	Boudreaux et al.
D822,206 S	7/2018	Shelton, IV et al.	10,098,635 B2	10/2018	Burbank
10,010,322 B2	7/2018	Shelton, IV et al.	10,098,636 B2	10/2018	Shelton, IV et al.
10,010,324 B2	7/2018	Huitema et al.	10,098,640 B2	10/2018	Bertolero et al.
10,010,395 B2	7/2018	Puckett et al.	10,098,642 B2	10/2018	Baxter, III et al.
10,013,049 B2	7/2018	Leimbach et al.	10,099,303 B2	10/2018	Yoshida et al.
10,016,199 B2	7/2018	Baber et al.	10,101,861 B2	10/2018	Kiyoto
10,016,656 B2	7/2018	Devor et al.	10,105,126 B2	10/2018	Sauer
10,022,120 B2	7/2018	Martin et al.	10,105,128 B2	10/2018	Cooper et al.
10,022,123 B2	7/2018	Williams et al.	10,105,136 B2	10/2018	Yates et al.
10,022,125 B2	7/2018	(Prommersberger) Stopek et al.	10,105,139 B2	10/2018	Yates et al.
10,024,407 B2	7/2018	Aranyi et al.	10,105,140 B2	10/2018	Malinouskas et al.
10,028,742 B2	7/2018	Shelton, IV et al.	10,105,142 B2	10/2018	Baxter, III et al.
10,028,743 B2	7/2018	Shelton, IV et al.	10,105,149 B2	10/2018	Haider et al.
10,028,744 B2	7/2018	Shelton, IV et al.	10,106,932 B2	10/2018	Anderson et al.
10,028,761 B2	7/2018	Leimbach et al.	10,111,657 B2	10/2018	McCuen
10,029,108 B2	7/2018	Powers et al.	10,111,658 B2	10/2018	Chowaniec et al.
10,029,125 B2	7/2018	Shapiro et al.	10,111,660 B2	10/2018	Hemmann
10,034,344 B2	7/2018	Yoshida	10,111,665 B2	10/2018	Aranyi et al.
10,034,668 B2	7/2018	Ebner	10,111,679 B2	10/2018	Baber et al.
D826,405 S	8/2018	Shelton, IV et al.	10,111,698 B2	10/2018	Scheib et al.
10,039,440 B2	8/2018	Fenech et al.	10,111,702 B2	10/2018	Kostrzewski
10,039,529 B2	8/2018	Kerr et al.	D833,608 S	11/2018	Miller et al.
10,039,532 B2	8/2018	Srinivas et al.	10,117,649 B2	11/2018	Baxter et al.
10,039,545 B2	8/2018	Sadowski et al.	10,117,650 B2	11/2018	Nicholas et al.
10,041,822 B2	8/2018	Zemlok	10,117,652 B2	11/2018	Schmid et al.
10,045,769 B2	8/2018	Aronhalt et al.	10,117,653 B2	11/2018	Leimbach et al.
10,045,776 B2	8/2018	Shelton, IV et al.	10,117,654 B2	11/2018	Ingmanson et al.
10,045,778 B2	8/2018	Yates et al.	10,123,798 B2	11/2018	Baxter, III et al.
10,045,779 B2	8/2018	Savage et al.	10,123,845 B2	11/2018	Yeung
10,045,781 B2	8/2018	Cropper et al.	10,124,493 B2	11/2018	Rothfuss et al.
10,045,782 B2	8/2018	Murthy Aravalli	10,130,352 B2	11/2018	Widenhouse et al.
10,045,869 B2	8/2018	Forsell	10,130,359 B2	11/2018	Hess et al.
10,046,904 B2	8/2018	Evans et al.	10,130,360 B2	11/2018	Olson et al.
10,052,044 B2	8/2018	Shelton, IV et al.	10,130,361 B2	11/2018	Yates et al.
10,052,099 B2	8/2018	Morgan et al.	10,130,363 B2	11/2018	Huitema et al.
10,052,100 B2	8/2018	Morgan et al.	10,130,366 B2	11/2018	Shelton, IV et al.
10,052,102 B2	8/2018	Baxter, III et al.	10,130,367 B2	11/2018	Cappola et al.
10,052,104 B2	8/2018	Shelton, IV et al.	10,130,382 B2	11/2018	Gladstone
10,052,164 B2	8/2018	Overmyer	10,130,738 B2	11/2018	Shelton, IV et al.
10,058,317 B2	8/2018	Fan et al.	10,130,830 B2	11/2018	Miret Carceller et al.
10,058,327 B2	8/2018	Weisenburgh, II et al.	10,133,248 B2	11/2018	Fitzsimmons et al.
10,058,373 B2	8/2018	Takashino et al.	10,135,242 B2	11/2018	Baber et al.
10,058,395 B2	8/2018	Devengenzo et al.	10,136,879 B2	11/2018	Ross et al.
10,058,963 B2	8/2018	Shelton, IV et al.	10,136,887 B2	11/2018	Shelton, IV et al.
10,064,620 B2	9/2018	Gettinger et al.	10,136,889 B2	11/2018	Shelton, IV et al.
10,064,621 B2	9/2018	Kerr et al.	10,136,890 B2	11/2018	Shelton, IV et al.
10,064,622 B2	9/2018	Murthy Aravalli	10,136,891 B2	11/2018	Shelton, IV et al.
10,064,624 B2	9/2018	Shelton, IV et al.	D835,659 S	12/2018	Anzures et al.
10,064,639 B2	9/2018	Ishida et al.	D836,124 S	12/2018	Fan
10,064,649 B2	9/2018	Golebieski et al.	10,143,474 B2	12/2018	Bucciaglia et al.
10,064,688 B2	9/2018	Shelton, IV et al.	10,149,679 B2	12/2018	Shelton, IV et al.
10,070,861 B2	9/2018	Spivey et al.	10,149,680 B2	12/2018	Parihar et al.
10,070,863 B2	9/2018	Swayze et al.	10,149,682 B2	12/2018	Shelton, IV et al.
10,071,452 B2	9/2018	Shelton, IV et al.	10,149,683 B2	12/2018	Smith et al.
10,076,325 B2	9/2018	Huang et al.	10,149,712 B2	12/2018	Manwaring et al.
10,076,326 B2	9/2018	Yates et al.	10,152,789 B2	12/2018	Carnes et al.
10,076,340 B2	9/2018	Belagali et al.	10,154,841 B2	12/2018	Weaner et al.
10,080,552 B2	9/2018	Nicholas et al.	10,159,481 B2	12/2018	Whitman et al.
D830,550 S	10/2018	Miller et al.	10,159,482 B2	12/2018	Swayze et al.
D831,209 S *	10/2018	Huitema A61B 17/07207 D24/145	10,159,483 B2	12/2018	Beckman et al.
D831,676 S	10/2018	Park et al.	10,159,506 B2	12/2018	Boudreaux et al.
D832,301 S	10/2018	Smith	10,161,816 B2	12/2018	Jackson et al.
10,085,624 B2	10/2018	Isoda et al.	10,163,065 B1	12/2018	Koski et al.
10,085,643 B2	10/2018	Bandic et al.	10,163,589 B2	12/2018	Zergiebel et al.
10,085,728 B2	10/2018	Jogasaki et al.	10,164,466 B2	12/2018	Calderoni
10,085,746 B2	10/2018	Fischvogt	D837,244 S	1/2019	Kuo et al.
10,085,748 B2	10/2018	Morgan et al.	D837,245 S	1/2019	Kuo et al.
10,085,749 B2	10/2018	Cappola et al.	10,166,023 B2	1/2019	Vendely et al.
10,085,750 B2	10/2018	Zergiebel et al.	10,166,025 B2	1/2019	Leimbach et al.
			10,166,026 B2	1/2019	Shelton, IV et al.
			10,172,611 B2	1/2019	Shelton, IV et al.
			10,172,615 B2	1/2019	Marczyk et al.
			10,172,616 B2	1/2019	Murray et al.
			10,172,617 B2	1/2019	Shelton, IV et al.

(56)

References Cited

U.S. PATENT DOCUMENTS

10,172,618 B2	1/2019	Shelton, IV et al.	10,245,029 B2	4/2019	Hunter et al.
10,172,619 B2	1/2019	Harris et al.	10,245,030 B2	4/2019	Hunter et al.
10,172,620 B2	1/2019	Harris et al.	10,245,032 B2	4/2019	Shelton, IV
10,172,636 B2	1/2019	Stulen et al.	10,245,033 B2	4/2019	Overmyer et al.
10,172,669 B2	1/2019	Felder et al.	10,245,034 B2	4/2019	Shelton, IV et al.
10,175,127 B2	1/2019	Collins et al.	10,245,035 B2	4/2019	Swayze et al.
10,178,992 B2	1/2019	Wise et al.	10,245,038 B2	4/2019	Hopkins et al.
10,180,463 B2	1/2019	Beckman et al.	10,245,058 B2	4/2019	Omori et al.
10,182,813 B2	1/2019	Leimbach et al.	10,251,648 B2	4/2019	Harris et al.
10,182,815 B2	1/2019	Williams et al.	10,251,649 B2	4/2019	Schellin et al.
10,182,816 B2	1/2019	Shelton, IV et al.	10,251,725 B2	4/2019	Valentine et al.
10,182,818 B2	1/2019	Hensel et al.	10,258,322 B2	4/2019	Fanton et al.
10,182,819 B2	1/2019	Shelton, IV	10,258,330 B2	4/2019	Shelton, IV et al.
10,182,868 B2	1/2019	Meier et al.	10,258,331 B2	4/2019	Shelton, IV et al.
10,188,385 B2	1/2019	Kerr et al.	10,258,332 B2	4/2019	Schmid et al.
10,188,389 B2	1/2019	Vendely et al.	10,258,333 B2	4/2019	Shelton, IV et al.
10,188,393 B2	1/2019	Smith et al.	10,258,336 B2	4/2019	Baxter, III et al.
10,188,394 B2	1/2019	Shelton, IV et al.	10,258,363 B2	4/2019	Worrell et al.
10,190,888 B2	1/2019	Hryb et al.	10,258,418 B2	4/2019	Shelton, IV et al.
D839,900 S	2/2019	Gan	10,264,797 B2	4/2019	Zhang et al.
D841,667 S	2/2019	Coren	10,265,065 B2	4/2019	Shelton, IV et al.
10,194,801 B2	2/2019	Elhawary et al.	10,265,067 B2	4/2019	Yates et al.
10,194,904 B2	2/2019	Viola et al.	10,265,068 B2	4/2019	Harris et al.
10,194,907 B2	2/2019	Marczyk et al.	10,265,072 B2	4/2019	Shelton, IV et al.
10,194,908 B2	2/2019	Duque et al.	10,265,073 B2	4/2019	Scheib et al.
10,194,910 B2	2/2019	Shelton, IV et al.	10,265,074 B2	4/2019	Shelton, IV et al.
10,194,911 B2	2/2019	Miller et al.	10,265,090 B2	4/2019	Ingmanson et al.
10,194,912 B2	2/2019	Scheib et al.	10,271,840 B2	4/2019	Sapre
10,194,913 B2	2/2019	Nalagatla et al.	10,271,844 B2	4/2019	Valentine et al.
10,194,976 B2	2/2019	Boudreaux	10,271,845 B2	4/2019	Shelton, IV
10,194,992 B2	2/2019	Robinson	10,271,846 B2	4/2019	Shelton, IV et al.
10,201,348 B2	2/2019	Scheib et al.	10,271,847 B2	4/2019	Racenet et al.
10,201,349 B2	2/2019	Leimbach et al.	10,271,849 B2	4/2019	Vendely et al.
10,201,363 B2	2/2019	Shelton, IV	10,271,851 B2	4/2019	Shelton, IV et al.
10,201,364 B2	2/2019	Leimbach et al.	D847,989 S	5/2019	Shelton, IV et al.
10,201,365 B2	2/2019	Boudreaux et al.	D848,473 S	5/2019	Zhu et al.
10,201,381 B2	2/2019	Zergiebel et al.	D849,046 S	5/2019	Kuo et al.
10,206,605 B2	2/2019	Shelton, IV et al.	10,278,696 B2	5/2019	Gurumurthy et al.
10,206,676 B2	2/2019	Shelton, IV	10,278,697 B2	5/2019	Shelton, IV et al.
10,206,677 B2	2/2019	Harris et al.	10,278,702 B2	5/2019	Shelton, IV et al.
10,206,678 B2	2/2019	Shelton, IV et al.	10,278,703 B2	5/2019	Nativ et al.
10,206,748 B2	2/2019	Burbank	10,278,707 B2	5/2019	Thompson et al.
10,210,244 B1	2/2019	Branavan et al.	10,278,722 B2	5/2019	Shelton, IV et al.
10,211,586 B2	2/2019	Adams et al.	10,278,780 B2	5/2019	Shelton, IV
10,213,198 B2	2/2019	Aronhalt et al.	10,285,694 B2	5/2019	Viola et al.
10,213,201 B2	2/2019	Shelton, IV et al.	10,285,695 B2	5/2019	Jaworek et al.
10,213,202 B2	2/2019	Flanagan et al.	10,285,699 B2	5/2019	Vendely et al.
10,213,203 B2	2/2019	Swayze et al.	10,285,700 B2	5/2019	Scheib
10,213,204 B2	2/2019	Aranyi et al.	10,285,705 B2	5/2019	Shelton, IV et al.
10,213,262 B2	2/2019	Shelton, IV et al.	10,292,701 B2	5/2019	Scheib et al.
D842,328 S	3/2019	Jian et al.	10,292,704 B2	5/2019	Harris et al.
10,219,811 B2	3/2019	Haider et al.	10,292,707 B2	5/2019	Shelton, IV et al.
10,219,832 B2	3/2019	Bagwell et al.	10,293,100 B2	5/2019	Shelton, IV et al.
10,220,522 B2	3/2019	Rockrohr	10,293,553 B2	5/2019	Racenet et al.
10,226,239 B2	3/2019	Nicholas et al.	10,299,787 B2	5/2019	Shelton, IV
10,226,249 B2	3/2019	Jaworek et al.	10,299,788 B2	5/2019	Heinrich et al.
10,226,250 B2	3/2019	Beckman et al.	10,299,789 B2	5/2019	Marczyk et al.
10,226,251 B2	3/2019	Scheib et al.	10,299,790 B2	5/2019	Beardsley
10,226,274 B2	3/2019	Worrell et al.	10,299,792 B2	5/2019	Huitema et al.
10,231,634 B2	3/2019	Zand et al.	10,299,817 B2	5/2019	Shelton, IV et al.
10,231,653 B2	3/2019	Bohm et al.	10,299,818 B2	5/2019	Riva
10,231,734 B2	3/2019	Thompson et al.	10,303,851 B2	5/2019	Nguyen et al.
10,231,794 B2	3/2019	Shelton, IV et al.	D850,617 S	6/2019	Shelton, IV et al.
10,238,386 B2	3/2019	Overmyer et al.	D851,676 S	6/2019	Foss et al.
10,238,387 B2	3/2019	Yates et al.	D851,762 S	6/2019	Shelton, IV et al.
10,238,389 B2	3/2019	Yates et al.	10,307,159 B2	6/2019	Harris et al.
10,238,390 B2	3/2019	Harris et al.	10,307,160 B2	6/2019	Vendely et al.
10,238,391 B2	3/2019	Leimbach et al.	10,307,161 B2	6/2019	Jankowski
D844,666 S	4/2019	Espeleta et al.	10,307,163 B2	6/2019	Moore et al.
D844,667 S	4/2019	Espeleta et al.	10,307,170 B2	6/2019	Parfett et al.
D845,342 S	4/2019	Espeleta et al.	10,307,202 B2	6/2019	Smith et al.
D847,199 S	4/2019	Whitmore	10,314,559 B2	6/2019	Razzaque et al.
10,244,991 B2	4/2019	Shademan et al.	10,314,577 B2	6/2019	Laurent et al.
10,245,027 B2	4/2019	Shelton, IV et al.	10,314,578 B2	6/2019	Leimbach et al.
10,245,028 B2	4/2019	Shelton, IV et al.	10,314,580 B2	6/2019	Scheib et al.
			10,314,582 B2	6/2019	Shelton, IV et al.
			10,314,584 B2	6/2019	Scirica et al.
			10,314,587 B2	6/2019	Harris et al.
			10,314,588 B2	6/2019	Turner et al.

(56)

References Cited

U.S. PATENT DOCUMENTS

10,314,589 B2	6/2019	Shelton, IV et al.	10,405,914 B2	9/2019	Manwaring et al.
10,314,590 B2	6/2019	Shelton, IV et al.	10,405,932 B2	9/2019	Overmyer
10,315,566 B2	6/2019	Choi et al.	10,405,937 B2	9/2019	Black et al.
10,321,907 B2	6/2019	Shelton, IV et al.	10,413,155 B2	9/2019	Inoue
10,321,909 B2	6/2019	Shelton, IV et al.	10,413,291 B2	9/2019	Worthington et al.
10,321,927 B2	6/2019	Hinman	10,413,293 B2	9/2019	Shelton, IV et al.
10,327,743 B2	6/2019	St. Goar et al.	10,413,294 B2	9/2019	Shelton, IV et al.
10,327,764 B2	6/2019	Harris et al.	10,413,297 B2	9/2019	Harris et al.
10,327,765 B2	6/2019	Timm et al.	10,413,370 B2	9/2019	Yates et al.
10,327,767 B2	6/2019	Shelton, IV et al.	10,413,373 B2	9/2019	Yates et al.
10,327,769 B2	6/2019	Overmyer et al.	10,420,548 B2	9/2019	Whitman et al.
10,327,776 B2	6/2019	Harris et al.	10,420,549 B2	9/2019	Yates et al.
10,327,777 B2	6/2019	Harris et al.	10,420,550 B2	9/2019	Shelton, IV
D854,032 S	7/2019	Jones et al.	10,420,551 B2	9/2019	Calderoni
D854,151 S	7/2019	Shelton, IV et al.	10,420,552 B2	9/2019	Shelton, IV et al.
10,335,144 B2	7/2019	Shelton, IV et al.	10,420,553 B2	9/2019	Shelton, IV et al.
10,335,145 B2	7/2019	Harris et al.	10,420,554 B2	9/2019	Collings et al.
10,335,147 B2	7/2019	Rector et al.	10,420,555 B2	9/2019	Shelton, IV et al.
10,335,148 B2	7/2019	Shelton, IV et al.	10,420,558 B2	9/2019	Nalagatla et al.
10,335,149 B2	7/2019	Baxter, III et al.	10,420,559 B2	9/2019	Marczyk et al.
10,335,150 B2	7/2019	Shelton, IV	10,420,560 B2	9/2019	Shelton, IV et al.
10,335,151 B2	7/2019	Shelton, IV et al.	10,420,561 B2	9/2019	Shelton, IV et al.
10,337,148 B2	7/2019	Rouse et al.	10,420,577 B2	9/2019	Chowaniec et al.
10,342,533 B2	7/2019	Shelton, IV et al.	D861,707 S	10/2019	Yang
10,342,535 B2	7/2019	Scheib et al.	D862,518 S	10/2019	Niven et al.
10,342,541 B2	7/2019	Shelton, IV et al.	D863,343 S	10/2019	Mazlish et al.
10,342,543 B2	7/2019	Shelton, IV et al.	D864,388 S	10/2019	Barber
10,342,623 B2	7/2019	Huelman et al.	D865,174 S	10/2019	Auld et al.
10,349,937 B2	7/2019	Williams	D865,175 S	10/2019	Widenhouse et al.
10,349,939 B2	7/2019	Shelton, IV et al.	10,426,463 B2	10/2019	Shelton, IV et al.
10,349,941 B2	7/2019	Marczyk et al.	10,426,466 B2	10/2019	Contini et al.
10,349,963 B2	7/2019	Fiksen et al.	10,426,467 B2	10/2019	Miller et al.
10,350,016 B2	7/2019	Burbank et al.	10,426,468 B2	10/2019	Contini et al.
10,357,246 B2	7/2019	Shelton, IV et al.	10,426,469 B2	10/2019	Shelton, IV et al.
10,357,247 B2	7/2019	Shelton, IV et al.	10,426,471 B2	10/2019	Shelton, IV et al.
10,357,248 B2	7/2019	Dalessandro et al.	10,426,476 B2	10/2019	Harris et al.
10,357,252 B2	7/2019	Harris et al.	10,426,477 B2	10/2019	Harris et al.
10,363,031 B2	7/2019	Alexander, III et al.	10,426,478 B2	10/2019	Shelton, IV et al.
10,363,033 B2	7/2019	Timm et al.	10,426,481 B2	10/2019	Aronhalt et al.
10,363,036 B2	7/2019	Yates et al.	10,426,555 B2	10/2019	Crowley et al.
10,363,037 B2	7/2019	Aronhalt et al.	10,433,837 B2	10/2019	Worthington et al.
D855,634 S	8/2019	Kim	10,433,839 B2	10/2019	Scheib et al.
D856,359 S	8/2019	Huang et al.	10,433,840 B2	10/2019	Shelton, IV et al.
10,368,838 B2	8/2019	Williams et al.	10,433,844 B2	10/2019	Shelton, IV et al.
10,368,861 B2	8/2019	Baxter, III et al.	10,433,845 B2	10/2019	Baxter, III et al.
10,368,863 B2	8/2019	Timm et al.	10,433,846 B2	10/2019	Vendely et al.
10,368,864 B2	8/2019	Harris et al.	10,433,849 B2	10/2019	Shelton, IV et al.
10,368,865 B2	8/2019	Harris et al.	10,433,918 B2	10/2019	Shelton, IV et al.
10,368,867 B2	8/2019	Harris et al.	10,441,279 B2	10/2019	Shelton, IV et al.
10,368,892 B2	8/2019	Stulen et al.	10,441,280 B2	10/2019	Timm et al.
10,376,263 B2	8/2019	Morgan et al.	10,441,281 B2	10/2019	Shelton, IV et al.
10,383,626 B2	8/2019	Soltz	10,441,285 B2	10/2019	Shelton, IV et al.
10,383,628 B2	8/2019	Kang et al.	10,441,286 B2	10/2019	Shelton, IV et al.
10,383,629 B2	8/2019	Ross et al.	10,441,345 B2	10/2019	Aldridge et al.
10,383,630 B2	8/2019	Shelton, IV et al.	10,441,369 B2	10/2019	Shelton, IV et al.
10,383,633 B2	8/2019	Shelton, IV et al.	10,448,948 B2	10/2019	Shelton, IV et al.
10,383,634 B2	8/2019	Shelton, IV et al.	10,448,950 B2	10/2019	Shelton, IV et al.
10,390,823 B2	8/2019	Shelton, IV et al.	10,448,952 B2	10/2019	Shelton, IV et al.
10,390,825 B2	8/2019	Shelton, IV et al.	10,456,122 B2	10/2019	Koltz et al.
10,390,828 B2	8/2019	Vendely et al.	10,456,132 B2	10/2019	Gettinger et al.
10,390,829 B2	8/2019	Eckert et al.	10,456,133 B2	10/2019	Yates et al.
10,390,830 B2	8/2019	Schulz	10,456,137 B2	10/2019	Vendely et al.
10,390,841 B2	8/2019	Shelton, IV et al.	10,456,140 B2	10/2019	Shelton, IV et al.
10,390,897 B2	8/2019	Kostrzewski	D865,796 S	11/2019	Xu et al.
D860,219 S	9/2019	Rasmussen et al.	10,463,367 B2	11/2019	Kostrzewski et al.
D861,035 S	9/2019	Park et al.	10,463,369 B2	11/2019	Shelton, IV et al.
10,398,433 B2	9/2019	Boudreaux et al.	10,463,370 B2	11/2019	Yates et al.
10,398,434 B2	9/2019	Shelton, IV et al.	10,463,371 B2	11/2019	Kostrzewski
10,398,436 B2	9/2019	Shelton, IV et al.	10,463,372 B2	11/2019	Shelton, IV et al.
10,398,460 B2	9/2019	Overmyer	10,463,373 B2	11/2019	Mozdzierz et al.
10,404,136 B2	9/2019	Oktavec et al.	10,463,382 B2	11/2019	Ingmanson et al.
10,405,854 B2	9/2019	Schmid et al.	10,463,383 B2	11/2019	Shelton, IV et al.
10,405,857 B2	9/2019	Shelton, IV et al.	10,463,384 B2	11/2019	Shelton, IV et al.
10,405,859 B2	9/2019	Harris et al.	10,470,762 B2	11/2019	Leimbach et al.
10,405,863 B2	9/2019	Wise et al.	10,470,763 B2	11/2019	Yates et al.
			10,470,764 B2	11/2019	Baxter, III et al.
			10,470,767 B2	11/2019	Gleiman et al.
			10,470,768 B2	11/2019	Harris et al.
			10,470,769 B2	11/2019	Shelton, IV et al.

(56)

References Cited

U.S. PATENT DOCUMENTS

10,471,282 B2	11/2019	Kirk et al.	10,561,432 B2	2/2020	Estrella et al.
10,471,576 B2	11/2019	Totsu	10,561,474 B2	2/2020	Adams et al.
10,471,607 B2	11/2019	Butt et al.	10,562,160 B2	2/2020	Iwata et al.
10,478,181 B2	11/2019	Shelton, IV et al.	10,568,493 B2	2/2020	Blase et al.
10,478,182 B2	11/2019	Taylor	10,568,621 B2	2/2020	Shelton, IV et al.
10,478,185 B2	11/2019	Nicholas	10,568,624 B2	2/2020	Shelton, IV et al.
10,478,187 B2	11/2019	Shelton, IV et al.	10,568,625 B2	2/2020	Harris et al.
10,478,188 B2	11/2019	Harris et al.	10,568,626 B2	2/2020	Shelton, IV et al.
10,478,189 B2	11/2019	Bear et al.	10,568,629 B2	2/2020	Shelton, IV et al.
10,478,190 B2	11/2019	Miller et al.	10,568,632 B2	2/2020	Miller et al.
10,478,207 B2	11/2019	Lathrop	10,568,652 B2	2/2020	Hess et al.
10,482,292 B2	11/2019	Clouser et al.	10,569,071 B2	2/2020	Harris et al.
10,485,536 B2	11/2019	Ming et al.	D879,808 S	3/2020	Harris et al.
10,485,537 B2	11/2019	Yates et al.	D879,809 S	3/2020	Harris et al.
10,485,539 B2	11/2019	Shelton, IV et al.	10,575,868 B2	3/2020	Hall et al.
10,485,541 B2	11/2019	Shelton, IV et al.	10,580,320 B2	3/2020	Kamiguchi et al.
10,485,542 B2	11/2019	Shelton, IV et al.	10,582,928 B2	3/2020	Hunter et al.
10,485,543 B2	11/2019	Shelton, IV et al.	10,588,231 B2	3/2020	Sgroi, Jr. et al.
10,485,546 B2	11/2019	Shelton, IV et al.	10,588,623 B2	3/2020	Schmid et al.
10,485,547 B2	11/2019	Shelton, IV et al.	10,588,625 B2	3/2020	Weaner et al.
D869,655 S *	12/2019	Shelton, IV A61B 17/072 D24/145	10,588,626 B2	3/2020	Overmyer et al.
D870,742 S	12/2019	Cornell	10,588,629 B2	3/2020	Malinouskas et al.
10,492,783 B2	12/2019	Shelton, IV et al.	10,588,630 B2	3/2020	Shelton, IV et al.
10,492,785 B2	12/2019	Overmyer et al.	10,588,631 B2	3/2020	Shelton, IV et al.
10,492,787 B2	12/2019	Smith et al.	10,588,632 B2	3/2020	Shelton, IV et al.
10,492,814 B2	12/2019	Snow et al.	10,588,633 B2	3/2020	Shelton, IV et al.
10,492,847 B2	12/2019	Godara et al.	10,595,835 B2	3/2020	Kerr et al.
10,492,851 B2	12/2019	Hughett, Sr. et al.	10,595,862 B2	3/2020	Shelton, IV et al.
10,498,269 B2	12/2019	Zemlok et al.	10,595,882 B2	3/2020	Parfett et al.
10,499,890 B2	12/2019	Shelton, IV et al.	10,595,887 B2	3/2020	Shelton, IV et al.
10,499,914 B2	12/2019	Huang et al.	10,595,929 B2	3/2020	Boudreaux et al.
10,499,917 B2	12/2019	Scheib et al.	10,603,036 B2	3/2020	Hunter et al.
10,499,918 B2	12/2019	Schellin et al.	10,603,039 B2	3/2020	Vendely et al.
10,500,000 B2	12/2019	Swayze et al.	10,603,041 B2	3/2020	Miller et al.
10,500,309 B2	12/2019	Shah et al.	10,603,117 B2	3/2020	Schings et al.
10,507,034 B2	12/2019	Timm	10,603,128 B2	3/2020	Zergiebel et al.
10,508,720 B2	12/2019	Nicholas	10,610,224 B2	4/2020	Shelton, IV et al.
10,512,461 B2	12/2019	Gupta et al.	10,610,236 B2	4/2020	Baril
10,512,462 B2	12/2019	Felder et al.	10,610,313 B2	4/2020	Bailey et al.
10,517,590 B2	12/2019	Giordano et al.	10,610,346 B2	4/2020	Schwartz
10,517,592 B2	12/2019	Shelton, IV et al.	10,617,411 B2	4/2020	Williams
10,517,594 B2	12/2019	Shelton, IV et al.	10,617,412 B2	4/2020	Shelton, IV et al.
10,517,595 B2	12/2019	Hunter et al.	10,617,413 B2	4/2020	Shelton, IV et al.
10,517,596 B2	12/2019	Hunter et al.	10,617,414 B2	4/2020	Shelton, IV et al.
10,517,599 B2	12/2019	Baxter, III et al.	10,617,416 B2	4/2020	Leimbach et al.
10,517,682 B2	12/2019	Giordano et al.	10,617,417 B2	4/2020	Baxter, III et al.
10,524,784 B2	1/2020	Kostrzewski	10,617,418 B2	4/2020	Barton et al.
10,524,787 B2	1/2020	Shelton, IV et al.	10,617,420 B2	4/2020	Shelton, IV et al.
10,524,788 B2	1/2020	Vendely et al.	10,624,616 B2	4/2020	Mukherjee et al.
10,524,789 B2	1/2020	Swayze et al.	10,624,630 B2	4/2020	Deville et al.
10,524,790 B2	1/2020	Shelton, IV et al.	10,624,633 B2	4/2020	Shelton, IV et al.
10,524,795 B2	1/2020	Nalagatla et al.	10,624,634 B2	4/2020	Shelton, IV et al.
10,531,874 B2	1/2020	Morgan et al.	10,624,635 B2	4/2020	Harris et al.
10,531,887 B2	1/2020	Shelton, IV et al.	10,624,709 B2	4/2020	Remm
10,537,324 B2	1/2020	Shelton, IV et al.	10,624,861 B2	4/2020	Widenhouse et al.
10,537,325 B2	1/2020	Bakos et al.	10,625,062 B2	4/2020	Matlock et al.
10,537,351 B2	1/2020	Shelton, IV et al.	10,631,857 B2	4/2020	Kostrzewski
10,542,908 B2	1/2020	Mei et al.	10,631,858 B2	4/2020	Burbank
10,542,974 B2	1/2020	Yates et al.	10,631,859 B2	4/2020	Shelton, IV et al.
10,542,976 B2	1/2020	Calderoni et al.	10,631,860 B2	4/2020	Bakos et al.
10,542,978 B2	1/2020	Chowaniec et al.	10,636,104 B2	4/2020	Mazar et al.
10,542,979 B2	1/2020	Shelton, IV et al.	10,639,018 B2	5/2020	Shelton, IV et al.
10,542,982 B2	1/2020	Beckman et al.	10,639,034 B2	5/2020	Harris et al.
10,542,985 B2	1/2020	Zhan et al.	10,639,035 B2	5/2020	Shelton, IV et al.
10,542,988 B2	1/2020	Schellin et al.	10,639,036 B2	5/2020	Yates et al.
10,542,991 B2	1/2020	Shelton, IV et al.	10,639,037 B2	5/2020	Shelton, IV et al.
10,548,504 B2	2/2020	Shelton, IV et al.	10,639,089 B2	5/2020	Manwaring et al.
10,548,593 B2	2/2020	Shelton, IV et al.	10,639,115 B2	5/2020	Shelton, IV et al.
10,548,600 B2	2/2020	Shelton, IV et al.	10,642,633 B1	5/2020	Chopra et al.
10,548,673 B2	2/2020	Harris et al.	10,645,905 B2	5/2020	Gandola et al.
10,561,418 B2	2/2020	Richard et al.	10,646,220 B2	5/2020	Shelton, IV et al.
10,561,419 B2	2/2020	Beardsley	10,646,292 B2	5/2020	Solomon et al.
10,561,420 B2	2/2020	Harris et al.	10,653,413 B2	5/2020	Worthington et al.
10,561,422 B2	2/2020	Schellin et al.	10,653,417 B2	5/2020	Shelton, IV et al.
			10,653,435 B2	5/2020	Shelton, IV et al.
			10,660,640 B2	5/2020	Yates et al.
			10,667,408 B2	5/2020	Sgroi, Jr. et al.
			D888,953 S	6/2020	Baxter, III et al.
			10,667,808 B2	6/2020	Baxter, III et al.

(56)

References Cited

U.S. PATENT DOCUMENTS

10,667,809 B2	6/2020	Bakos et al.	10,743,868 B2	8/2020	Shelton, IV et al.
10,667,810 B2	6/2020	Shelton, IV et al.	10,743,870 B2	8/2020	Hall et al.
10,667,811 B2	6/2020	Harris et al.	10,743,872 B2	8/2020	Leimbach et al.
10,667,818 B2	6/2020	McLain et al.	10,743,873 B2	8/2020	Overmyer et al.
10,674,895 B2	6/2020	Yeung et al.	10,743,874 B2	8/2020	Shelton, IV et al.
10,675,021 B2	6/2020	Harris et al.	10,743,875 B2	8/2020	Shelton, IV et al.
10,675,024 B2	6/2020	Shelton, IV et al.	10,743,877 B2	8/2020	Shelton, IV et al.
10,675,025 B2	6/2020	Swayze et al.	10,743,930 B2	8/2020	Nagtegaal
10,675,026 B2	6/2020	Harris et al.	10,751,048 B2	8/2020	Whitman et al.
10,675,028 B2	6/2020	Shelton, IV et al.	10,751,053 B2	8/2020	Harris et al.
10,675,035 B2	6/2020	Zingman	10,751,076 B2	8/2020	Laurent et al.
10,675,102 B2	6/2020	Forgione et al.	10,751,138 B2	8/2020	Giordano et al.
10,677,035 B2	6/2020	Balan et al.	10,758,229 B2	9/2020	Shelton, IV et al.
10,682,134 B2	6/2020	Shelton, IV et al.	10,758,230 B2	9/2020	Shelton, IV et al.
10,682,136 B2	6/2020	Harris et al.	10,758,232 B2	9/2020	Shelton, IV et al.
10,682,137 B2	6/2020	Stokes et al.	10,758,233 B2	9/2020	Scheib et al.
10,682,138 B2	6/2020	Shelton, IV et al.	10,758,259 B2	9/2020	Demmy et al.
10,682,141 B2	6/2020	Moore et al.	10,765,425 B2	9/2020	Yates et al.
10,682,142 B2	6/2020	Shelton, IV et al.	10,765,427 B2	9/2020	Shelton, IV et al.
10,687,806 B2	6/2020	Shelton, IV et al.	10,765,429 B2	9/2020	Leimbach et al.
10,687,809 B2	6/2020	Shelton, IV et al.	10,765,430 B2	9/2020	Wixey
10,687,810 B2	6/2020	Shelton, IV et al.	10,765,432 B2	9/2020	Moore et al.
10,687,812 B2	6/2020	Shelton, IV et al.	10,765,442 B2	9/2020	Strobl
10,687,813 B2	6/2020	Shelton, IV et al.	10,772,625 B2	9/2020	Shelton, IV et al.
10,687,817 B2	6/2020	Shelton, IV et al.	10,772,628 B2	9/2020	Chen et al.
10,687,819 B2	6/2020	Stokes et al.	10,772,629 B2	9/2020	Shelton, IV et al.
10,687,904 B2	6/2020	Harris et al.	10,772,630 B2	9/2020	Wixey
10,695,053 B2	6/2020	Hess et al.	10,772,631 B2	9/2020	Zergiebel et al.
10,695,055 B2	6/2020	Shelton, IV et al.	10,772,632 B2	9/2020	Kostrzewski
10,695,057 B2	6/2020	Shelton, IV et al.	10,772,651 B2	9/2020	Shelton, IV et al.
10,695,058 B2	6/2020	Lytle, IV et al.	10,779,818 B2	9/2020	Zemlok et al.
10,695,062 B2	6/2020	Leimbach et al.	10,779,820 B2	9/2020	Harris et al.
10,695,063 B2	6/2020	Morgan et al.	10,779,821 B2	9/2020	Harris et al.
10,695,074 B2	6/2020	Carusillo	10,779,822 B2	9/2020	Yates et al.
10,695,081 B2	6/2020	Shelton, IV et al.	10,779,823 B2	9/2020	Shelton, IV et al.
10,695,123 B2	6/2020	Allen, IV	10,779,824 B2	9/2020	Shelton, IV et al.
10,695,187 B2	6/2020	Moskowitz et al.	10,779,825 B2	9/2020	Shelton, IV et al.
D890,784 S	7/2020	Shelton, IV et al.	10,779,826 B2	9/2020	Shelton, IV et al.
10,702,266 B2	7/2020	Parihar et al.	10,779,903 B2	9/2020	Wise et al.
10,702,267 B2	7/2020	Hess et al.	10,780,539 B2	9/2020	Shelton, IV et al.
10,702,270 B2	7/2020	Shelton, IV et al.	10,786,248 B2	9/2020	Rousseau et al.
10,702,271 B2	7/2020	Aranyi et al.	10,786,253 B2	9/2020	Shelton, IV et al.
10,705,660 B2	7/2020	Xiao	10,786,255 B2	9/2020	Hodgkinson et al.
10,709,446 B2	7/2020	Harris et al.	10,792,038 B2	10/2020	Becerra et al.
10,709,468 B2	7/2020	Shelton, IV et al.	10,796,471 B2	10/2020	Leimbach et al.
10,709,469 B2	7/2020	Shelton, IV et al.	10,799,240 B2	10/2020	Shelton, IV et al.
10,709,496 B2	7/2020	Moua et al.	10,799,306 B2	10/2020	Robinson et al.
10,716,563 B2	7/2020	Shelton, IV et al.	10,806,448 B2	10/2020	Shelton, IV et al.
10,716,565 B2	7/2020	Shelton, IV et al.	10,806,449 B2	10/2020	Shelton, IV et al.
10,716,568 B2	7/2020	Hall et al.	10,806,450 B2	10/2020	Yates et al.
10,716,614 B2	7/2020	Yates et al.	10,806,451 B2	10/2020	Harris et al.
10,717,179 B2	7/2020	Koenig et al.	10,806,453 B2	10/2020	Chen et al.
10,722,232 B2	7/2020	Yates et al.	10,806,479 B2	10/2020	Shelton, IV et al.
10,722,233 B2	7/2020	Wellman	10,813,638 B2	10/2020	Shelton, IV et al.
10,722,292 B2	7/2020	Arya et al.	10,813,639 B2	10/2020	Shelton, IV et al.
10,722,293 B2	7/2020	Arya et al.	10,813,640 B2	10/2020	Adams et al.
10,722,317 B2	7/2020	Ward et al.	10,813,641 B2	10/2020	Setser et al.
D893,717 S	8/2020	Messerly et al.	10,813,683 B2	10/2020	Baxter, III et al.
10,729,432 B2	8/2020	Shelton, IV et al.	10,813,705 B2	10/2020	Hares et al.
10,729,436 B2	8/2020	Shelton, IV et al.	10,813,710 B2	10/2020	Grubbs
10,729,443 B2	8/2020	Cabrera et al.	10,820,939 B2	11/2020	Sartor
10,729,458 B2	8/2020	Stoddard et al.	10,828,028 B2	11/2020	Harris et al.
10,729,501 B2	8/2020	Leimbach et al.	10,828,030 B2	11/2020	Weir et al.
10,729,509 B2	8/2020	Shelton, IV et al.	10,828,032 B2	11/2020	Leimbach et al.
10,736,616 B2	8/2020	Scheib et al.	10,828,033 B2	11/2020	Shelton, IV et al.
10,736,628 B2	8/2020	Yates et al.	10,828,089 B2	11/2020	Clark et al.
10,736,629 B2	8/2020	Shelton, IV et al.	10,835,245 B2	11/2020	Swayze et al.
10,736,630 B2	8/2020	Huang et al.	10,835,246 B2	11/2020	Shelton, IV et al.
10,736,633 B2	8/2020	Vendely et al.	10,835,247 B2	11/2020	Shelton, IV et al.
10,736,634 B2	8/2020	Shelton, IV et al.	10,835,249 B2	11/2020	Schellin et al.
10,736,636 B2	8/2020	Baxter, III et al.	10,835,251 B2	11/2020	Shelton, IV et al.
10,736,644 B2	8/2020	Windolf et al.	10,835,330 B2	11/2020	Shelton, IV et al.
10,743,849 B2	8/2020	Shelton, IV et al.	10,842,357 B2	11/2020	Moskowitz et al.
10,743,850 B2	8/2020	Hibner et al.	10,842,473 B2	11/2020	Scheib et al.
10,743,851 B2	8/2020	Swayze et al.	10,842,488 B2	11/2020	Swayze et al.
			10,842,489 B2	11/2020	Shelton, IV
			10,842,490 B2	11/2020	DiNardo et al.
			10,842,491 B2	11/2020	Shelton, IV et al.
			10,842,492 B2	11/2020	Shelton, IV et al.

(56)

References Cited

U.S. PATENT DOCUMENTS

D904,612 S *	12/2020	Wynn	A61B 17/0684 D24/145	10,925,605 B2	2/2021	Moore et al.
D904,613 S	12/2020	Wynn et al.		D914,878 S	3/2021	Shelton, IV et al.
D906,355 S	12/2020	Messerly et al.		10,932,772 B2	3/2021	Shelton, IV et al.
10,849,621 B2	12/2020	Whitfield et al.		10,932,774 B2	3/2021	Shelton, IV
10,849,623 B2	12/2020	Dunki-Jacobs et al.		10,932,775 B2	3/2021	Shelton, IV et al.
10,849,697 B2	12/2020	Yates et al.		10,932,778 B2	3/2021	Smith et al.
10,856,866 B2	12/2020	Shelton, IV et al.		10,932,779 B2	3/2021	Vendely et al.
10,856,867 B2	12/2020	Shelton, IV et al.		10,932,784 B2	3/2021	Mozdzierz et al.
10,856,868 B2	12/2020	Shelton, IV et al.		10,932,804 B2	3/2021	Scheib et al.
10,856,869 B2	12/2020	Shelton, IV et al.		10,932,806 B2	3/2021	Shelton, IV et al.
10,856,870 B2	12/2020	Harris et al.		10,932,872 B2	3/2021	Shelton, IV et al.
10,863,981 B2	12/2020	Overmyer et al.		10,944,728 B2	3/2021	Wiener et al.
10,863,984 B2	12/2020	Shelton, IV et al.		10,945,727 B2	3/2021	Shelton, IV et al.
10,863,986 B2	12/2020	Yates et al.		10,945,728 B2	3/2021	Morgan et al.
10,869,664 B2	12/2020	Shelton, IV		10,945,729 B2	3/2021	Shelton, IV et al.
10,869,665 B2	12/2020	Shelton, IV et al.		10,945,731 B2	3/2021	Baxter, III et al.
10,869,666 B2	12/2020	Shelton, IV et al.		10,952,708 B2	3/2021	Scheib et al.
10,869,669 B2	12/2020	Shelton, IV et al.		10,952,726 B2	3/2021	Chowaniec
10,874,290 B2	12/2020	Walén et al.		10,952,727 B2	3/2021	Giordano et al.
10,874,391 B2	12/2020	Shelton, IV et al.		10,952,728 B2	3/2021	Shelton, IV et al.
10,874,392 B2	12/2020	Scirica et al.		10,952,759 B2	3/2021	Messerly et al.
10,874,393 B2	12/2020	Satti, III et al.		10,952,767 B2	3/2021	Kostrzewski et al.
10,874,396 B2	12/2020	Moore et al.		10,959,722 B2	3/2021	Morgan et al.
10,874,399 B2	12/2020	Zhang		10,959,725 B2	3/2021	Kerr et al.
10,879,275 B2	12/2020	Li et al.		10,959,727 B2	3/2021	Hunter et al.
D907,647 S	1/2021	Siebel et al.		10,959,731 B2	3/2021	Casasanta, Jr. et al.
D907,648 S	1/2021	Siebel et al.		10,959,744 B2	3/2021	Shelton, IV et al.
D908,216 S	1/2021	Messerly et al.		10,959,797 B2	3/2021	Licht et al.
10,881,395 B2	1/2021	Merchant et al.		D917,500 S	4/2021	Siebel et al.
10,881,396 B2	1/2021	Shelton, IV et al.		10,966,627 B2	4/2021	Shelton, IV et al.
10,881,399 B2	1/2021	Shelton, IV et al.		10,966,717 B2	4/2021	Shah et al.
10,881,401 B2	1/2021	Baber et al.		10,966,718 B2	4/2021	Shelton, IV et al.
10,881,446 B2	1/2021	Strobl		10,966,791 B2	4/2021	Harris et al.
10,888,318 B2	1/2021	Parihar et al.		10,973,515 B2	4/2021	Harris et al.
10,888,321 B2	1/2021	Shelton, IV et al.		10,973,516 B2	4/2021	Shelton, IV et al.
10,888,322 B2	1/2021	Morgan et al.		10,973,517 B2	4/2021	Wixey
10,888,323 B2	1/2021	Chen et al.		10,973,519 B2	4/2021	Weir et al.
10,888,325 B2	1/2021	Harris et al.		10,973,520 B2	4/2021	Shelton, IV et al.
10,888,328 B2	1/2021	Shelton, IV et al.		10,980,534 B2	4/2021	Yates et al.
10,888,329 B2	1/2021	Moore et al.		10,980,535 B2	4/2021	Yates et al.
10,888,330 B2	1/2021	Moore et al.		10,980,536 B2	4/2021	Weaner et al.
10,888,369 B2	1/2021	Messerly et al.		10,980,537 B2	4/2021	Shelton, IV et al.
10,892,899 B2	1/2021	Shelton, IV et al.		10,980,538 B2	4/2021	Nalagatla et al.
10,893,853 B2	1/2021	Shelton, IV et al.		10,980,539 B2	4/2021	Harris et al.
10,893,863 B2	1/2021	Shelton, IV et al.		10,980,560 B2	4/2021	Shelton, IV et al.
10,893,864 B2	1/2021	Harris et al.		10,983,646 B2	4/2021	Yoon et al.
10,893,867 B2	1/2021	Leimbach et al.		10,987,102 B2	4/2021	Gonzalez et al.
10,898,183 B2	1/2021	Shelton, IV et al.		10,987,178 B2	4/2021	Shelton, IV et al.
10,898,184 B2	1/2021	Yates et al.		10,993,713 B2	5/2021	Shelton, IV et al.
10,898,185 B2	1/2021	Overmyer et al.		10,993,715 B2	5/2021	Shelton, IV et al.
10,898,186 B2	1/2021	Bakos et al.		10,993,716 B2	5/2021	Shelton, IV et al.
10,898,190 B2	1/2021	Yates et al.		10,993,717 B2	5/2021	Shelton, IV et al.
10,898,193 B2	1/2021	Shelton, IV et al.		11,000,274 B2	5/2021	Shelton, IV et al.
10,898,194 B2	1/2021	Moore et al.		11,000,275 B2	5/2021	Shelton, IV et al.
10,898,195 B2	1/2021	Moore et al.		11,000,277 B2	5/2021	Giordano et al.
10,903,685 B2	1/2021	Yates et al.		11,000,278 B2	5/2021	Shelton, IV et al.
D910,847 S	2/2021	Shelton, IV et al.		11,000,279 B2	5/2021	Shelton, IV et al.
10,905,415 B2	2/2021	DiNardo et al.		11,006,951 B2	5/2021	Giordano et al.
10,905,418 B2	2/2021	Shelton, IV et al.		11,006,955 B2	5/2021	Shelton, IV et al.
10,905,420 B2	2/2021	Jasemian et al.		11,007,004 B2	5/2021	Shelton, IV et al.
10,905,422 B2	2/2021	Bakos et al.		11,007,022 B2	5/2021	Shelton, IV et al.
10,905,423 B2	2/2021	Baber et al.		11,013,511 B2	5/2021	Huang et al.
10,905,426 B2	2/2021	Moore et al.		11,013,552 B2	5/2021	Widenhouse et al.
10,905,427 B2	2/2021	Moore et al.		11,013,563 B2	5/2021	Shelton, IV et al.
10,911,515 B2	2/2021	Biasi et al.		11,020,016 B2	6/2021	Wallace et al.
10,912,559 B2	2/2021	Harris et al.		11,020,112 B2	6/2021	Shelton, IV et al.
10,912,562 B2	2/2021	Dunki-Jacobs et al.		11,020,113 B2	6/2021	Shelton, IV et al.
10,912,575 B2	2/2021	Shelton, IV et al.		11,020,114 B2	6/2021	Shelton, IV et al.
10,918,364 B2	2/2021	Applegate et al.		11,020,115 B2	6/2021	Scheib et al.
10,918,380 B2	2/2021	Morgan et al.		11,026,678 B2	6/2021	Overmyer et al.
10,918,385 B2	2/2021	Overmyer et al.		11,026,680 B2	6/2021	Shelton, IV et al.
10,918,386 B2	2/2021	Shelton, IV et al.		11,026,684 B2	6/2021	Shelton, IV et al.
10,919,156 B2	2/2021	Roberts et al.		11,026,687 B2	6/2021	Shelton, IV et al.
10,925,600 B2	2/2021	McCuen		11,026,712 B2	6/2021	Shelton, IV et al.
				11,026,713 B2	6/2021	Stokes et al.
				11,026,751 B2	6/2021	Shelton, IV et al.
				11,033,267 B2	6/2021	Shelton, IV et al.
				11,039,834 B2	6/2021	Harris et al.
				11,039,836 B2	6/2021	Shelton, IV et al.

(56)

References Cited

U.S. PATENT DOCUMENTS

11,039,837 B2	6/2021	Shelton, IV et al.	11,134,942 B2	10/2021	Harris et al.
11,045,189 B2	6/2021	Yates et al.	11,134,943 B2	10/2021	Giordano et al.
11,045,191 B2	6/2021	Shelton, IV et al.	11,134,944 B2	10/2021	Wise et al.
11,045,192 B2	6/2021	Harris et al.	11,134,947 B2	10/2021	Shelton, IV et al.
11,045,197 B2	6/2021	Shelton, IV et al.	11,135,352 B2	10/2021	Shelton, IV et al.
11,045,270 B2	6/2021	Shelton, IV et al.	11,141,153 B2	10/2021	Shelton, IV et al.
11,051,810 B2	7/2021	Harris et al.	11,141,154 B2	10/2021	Shelton, IV et al.
11,051,811 B2	7/2021	Shelton, IV et al.	11,141,155 B2	10/2021	Shelton, IV
11,051,813 B2	7/2021	Shelton, IV et al.	11,141,156 B2	10/2021	Shelton, IV
11,051,836 B2	7/2021	Shelton, IV et al.	11,141,160 B2	10/2021	Shelton, IV et al.
11,051,840 B2	7/2021	Shelton, IV et al.	11,147,547 B2	10/2021	Shelton, IV et al.
11,051,873 B2	7/2021	Wiener et al.	11,147,549 B2	10/2021	Timm et al.
11,058,418 B2	7/2021	Shelton, IV et al.	11,147,551 B2	10/2021	Shelton, IV
11,058,420 B2	7/2021	Shelton, IV et al.	11,147,553 B2	10/2021	Shelton, IV
11,058,422 B2	7/2021	Harris et al.	11,147,554 B2	10/2021	Aronhalt et al.
11,058,423 B2	7/2021	Shelton, IV et al.	11,154,296 B2	10/2021	Aronhalt et al.
11,058,424 B2	7/2021	Shelton, IV et al.	11,154,297 B2	10/2021	Swayze et al.
11,058,425 B2	7/2021	Widenhouse et al.	11,154,298 B2	10/2021	Timm et al.
11,058,426 B2	7/2021	Nalagatla et al.	11,154,299 B2	10/2021	Shelton, IV et al.
11,058,498 B2	7/2021	Shelton, IV et al.	11,154,300 B2	10/2021	Nalagatla et al.
11,064,997 B2	7/2021	Shelton, IV et al.	11,154,301 B2	10/2021	Beckman et al.
11,064,998 B2	7/2021	Shelton, IV	11,160,551 B2	11/2021	Shelton, IV et al.
11,065,048 B2	7/2021	Messerly et al.	11,160,553 B2	11/2021	Simms et al.
11,069,012 B2	7/2021	Shelton, IV et al.	11,160,601 B2	11/2021	Worrell et al.
11,071,542 B2	7/2021	Chen et al.	11,202,633 B2	12/2021	Harris et al.
11,071,543 B2	7/2021	Shelton, IV et al.	11,234,700 B2	2/2022	Ragosta et al.
11,071,545 B2	7/2021	Baber et al.	2001/0000531 A1	4/2001	Casscells et al.
11,071,554 B2	7/2021	Parfett et al.	2001/0025183 A1	9/2001	Shahidi
11,071,560 B2	7/2021	Deck et al.	2001/0025184 A1	9/2001	Messerly
11,076,853 B2	8/2021	Parfett et al.	2001/0034530 A1	10/2001	Malackowski et al.
11,076,854 B2	8/2021	Baber et al.	2002/0014510 A1	2/2002	Richter et al.
11,076,921 B2	8/2021	Shelton, IV et al.	2002/0022810 A1	2/2002	Urich
11,076,929 B2	8/2021	Shelton, IV et al.	2002/0022836 A1	2/2002	Goble et al.
11,083,452 B2	8/2021	Schmid et al.	2002/0022861 A1	2/2002	Jacobs et al.
11,083,453 B2	8/2021	Shelton, IV et al.	2002/0023126 A1	2/2002	Flavin
11,083,454 B2	8/2021	Harris et al.	2002/0029032 A1	3/2002	Arkin
11,083,455 B2	8/2021	Shelton, IV et al.	2002/0029036 A1	3/2002	Goble et al.
11,083,456 B2	8/2021	Shelton, IV et al.	2002/0042620 A1	4/2002	Julian et al.
11,083,457 B2	8/2021	Shelton, IV et al.	2002/0087048 A1	7/2002	Brock et al.
11,083,458 B2	8/2021	Harris et al.	2002/0091374 A1	7/2002	Cooper
11,090,045 B2	8/2021	Shelton, IV	2002/0095175 A1	7/2002	Brock et al.
11,090,046 B2	8/2021	Shelton, IV et al.	2002/0103494 A1	8/2002	Pacey
11,090,047 B2	8/2021	Shelton, IV et al.	2002/0111624 A1	8/2002	Witt et al.
11,090,048 B2	8/2021	Fanelli et al.	2002/0116063 A1	8/2002	Giannetti et al.
11,090,049 B2	8/2021	Bakos et al.	2002/0117534 A1	8/2002	Green et al.
11,090,075 B2	8/2021	Hunter et al.	2002/0127265 A1	9/2002	Bowman et al.
11,096,688 B2	8/2021	Shelton, IV et al.	2002/0128633 A1	9/2002	Brock et al.
11,096,689 B2	8/2021	Overmyer et al.	2002/0134811 A1	9/2002	Napier et al.
11,100,631 B2	8/2021	Yates et al.	2002/0135474 A1	9/2002	Sylliassen
11,103,241 B2	8/2021	Yates et al.	2002/0138086 A1	9/2002	Sixto et al.
11,103,248 B2	8/2021	Shelton, IV et al.	2002/0143340 A1	10/2002	Kaneko
11,103,268 B2	8/2021	Shelton, IV et al.	2002/0151770 A1	10/2002	Noll et al.
11,103,269 B2	8/2021	Shelton, IV et al.	2002/0158593 A1	10/2002	Henderson et al.
11,109,858 B2	9/2021	Shelton, IV et al.	2002/0177848 A1	11/2002	Truckai et al.
11,109,859 B2	9/2021	Overmyer et al.	2002/0185514 A1	12/2002	Adams et al.
11,109,860 B2	9/2021	Shelton, IV et al.	2002/0188170 A1	12/2002	Santamore et al.
11,109,866 B2	9/2021	Shelton, IV et al.	2002/0188287 A1	12/2002	Zvuloni et al.
11,109,878 B2	9/2021	Shelton, IV et al.	2003/0009193 A1	1/2003	Corsaro
11,109,925 B2	9/2021	Cooper et al.	2003/0011245 A1	1/2003	Fiebig
11,116,485 B2	9/2021	Scheib et al.	2003/0012805 A1	1/2003	Chen et al.
11,116,502 B2	9/2021	Shelton, IV et al.	2003/0040670 A1	2/2003	Govari
11,123,069 B2	9/2021	Baxter, III et al.	2003/0045835 A1	3/2003	Anderson et al.
11,123,070 B2	9/2021	Shelton, IV et al.	2003/0047230 A1	3/2003	Kim
11,129,611 B2	9/2021	Shelton, IV et al.	2003/0050654 A1	3/2003	Whitman et al.
11,129,613 B2	9/2021	Harris et al.	2003/0066858 A1	4/2003	Holgersson
11,129,615 B2	9/2021	Scheib et al.	2003/0078647 A1	4/2003	Vallana et al.
11,129,616 B2	9/2021	Shelton, IV et al.	2003/0083648 A1	5/2003	Wang et al.
11,129,634 B2	9/2021	Scheib et al.	2003/0084983 A1	5/2003	Rangachari et al.
11,129,636 B2	9/2021	Shelton, IV et al.	2003/0093103 A1	5/2003	Malackowski et al.
11,129,666 B2	9/2021	Messerly et al.	2003/0094356 A1	5/2003	Waldron
11,129,680 B2	9/2021	Shelton, IV et al.	2003/0096158 A1	5/2003	Takano et al.
11,132,462 B2	9/2021	Shelton, IV et al.	2003/0114851 A1	6/2003	Truckai et al.
11,133,106 B2	9/2021	Shelton, IV et al.	2003/0121586 A1	7/2003	Mitra et al.
11,134,938 B2	10/2021	Timm et al.	2003/0139741 A1	7/2003	Goble et al.
11,134,940 B2	10/2021	Shelton, IV et al.	2003/0149406 A1	8/2003	Martineau et al.
			2003/0153908 A1	8/2003	Goble et al.
			2003/0153968 A1	8/2003	Geis et al.
			2003/0163029 A1	8/2003	Sonnenschein et al.
			2003/0163085 A1	8/2003	Tanner et al.

(56)

References Cited

U.S. PATENT DOCUMENTS

2003/0164172	A1	9/2003	Chumas et al.	2005/0021078	A1	1/2005	Vleugels et al.
2003/0181900	A1	9/2003	Long	2005/0032511	A1	2/2005	Malone et al.
2003/0190584	A1	10/2003	Heasley	2005/0033352	A1	2/2005	Zepf et al.
2003/0195387	A1	10/2003	Kortenbach et al.	2005/0051163	A1	3/2005	Deem et al.
2003/0205029	A1	11/2003	Chapolini et al.	2005/0054946	A1	3/2005	Krzyzanowski
2003/0212005	A1	11/2003	Petito et al.	2005/0057225	A1	3/2005	Marquet
2003/0216732	A1	11/2003	Truckai et al.	2005/0058890	A1	3/2005	Brazell et al.
2003/0236505	A1	12/2003	Bonadio et al.	2005/0059997	A1	3/2005	Bauman et al.
2004/0006335	A1	1/2004	Garrison	2005/0067548	A1	3/2005	Inoue
2004/0006340	A1	1/2004	Latterell et al.	2005/0070929	A1	3/2005	Dalessandro et al.
2004/0007608	A1	1/2004	Ehrenfels et al.	2005/0075561	A1	4/2005	Golden
2004/0024457	A1	2/2004	Boyce et al.	2005/0080342	A1	4/2005	Gilreath et al.
2004/0028502	A1	2/2004	Cummins	2005/0085693	A1	4/2005	Belson et al.
2004/0030333	A1	2/2004	Goble	2005/0090817	A1	4/2005	Phan
2004/0034287	A1	2/2004	Hickle	2005/0096683	A1	5/2005	Ellins et al.
2004/0034357	A1	2/2004	Beane et al.	2005/0116673	A1	6/2005	Carl et al.
2004/0044295	A1	3/2004	Reinert et al.	2005/0120836	A1	6/2005	Anderson
2004/0044364	A1	3/2004	DeVries et al.	2005/0124855	A1	6/2005	Jaffe et al.
2004/0049121	A1	3/2004	Yaron	2005/0125897	A1	6/2005	Wyslucha et al.
2004/0049172	A1	3/2004	Root et al.	2005/0129735	A1	6/2005	Cook et al.
2004/0059362	A1	3/2004	Knodel et al.	2005/0130682	A1	6/2005	Takara et al.
2004/0068161	A1	4/2004	Couvillon	2005/0131173	A1	6/2005	McDaniel et al.
2004/0068224	A1	4/2004	Couvillon et al.	2005/0131211	A1	6/2005	Bayley et al.
2004/0068307	A1	4/2004	Goble	2005/0131390	A1	6/2005	Heinrich et al.
2004/0070369	A1	4/2004	Sakakibara	2005/0131436	A1	6/2005	Johnston et al.
2004/0073222	A1	4/2004	Koseki	2005/0131457	A1	6/2005	Douglas et al.
2004/0078037	A1	4/2004	Batchelor et al.	2005/0137454	A1	6/2005	Saadat et al.
2004/0082952	A1	4/2004	Dycus et al.	2005/0137455	A1	6/2005	Ewers et al.
2004/0085180	A1	5/2004	Juang	2005/0139636	A1	6/2005	Schwemberger et al.
2004/0092992	A1	5/2004	Adams et al.	2005/0143759	A1	6/2005	Kelly
2004/0093020	A1	5/2004	Sinton	2005/0143769	A1	6/2005	White et al.
2004/0093024	A1	5/2004	Lousararian et al.	2005/0145671	A1	7/2005	Viola
2004/0098040	A1	5/2004	Taniguchi et al.	2005/0150928	A1	7/2005	Kameyama et al.
2004/0101822	A1	5/2004	Wiesner et al.	2005/0154258	A1	7/2005	Tartaglia et al.
2004/0102783	A1	5/2004	Sutterlin et al.	2005/0154406	A1	7/2005	Bombard et al.
2004/0108357	A1	6/2004	Milliman et al.	2005/0159778	A1	7/2005	Heinrich et al.
2004/0110439	A1	6/2004	Chaikof et al.	2005/0165419	A1	7/2005	Sauer et al.
2004/0115022	A1	6/2004	Albertson et al.	2005/0169974	A1	8/2005	Tenerz et al.
2004/0116952	A1	6/2004	Sakurai et al.	2005/0171522	A1	8/2005	Christopherson
2004/0119185	A1	6/2004	Chen	2005/0177176	A1	8/2005	Gerbi et al.
2004/0122419	A1	6/2004	Neuberger	2005/0177181	A1	8/2005	Kagan et al.
2004/0122423	A1	6/2004	Dycus et al.	2005/0177249	A1	8/2005	Kladakis et al.
2004/0133095	A1	7/2004	Dunki-Jacobs et al.	2005/0182298	A1	8/2005	Ikeda et al.
2004/0133189	A1	7/2004	Sakurai	2005/0182443	A1	8/2005	Jonn et al.
2004/0143297	A1	7/2004	Ramsey	2005/0184121	A1	8/2005	Heinrich
2004/0147909	A1	7/2004	Johnston et al.	2005/0186240	A1	8/2005	Ringeisen et al.
2004/0153100	A1	8/2004	Ahlberg et al.	2005/0187545	A1	8/2005	Hooven et al.
2004/0158261	A1	8/2004	Vu	2005/0191936	A1	9/2005	Marine et al.
2004/0164123	A1	8/2004	Racenet et al.	2005/0203550	A1	9/2005	Laufer et al.
2004/0166169	A1	8/2004	Malaviya et al.	2005/0209614	A1	9/2005	Fenter et al.
2004/0167572	A1	8/2004	Roth et al.	2005/0216055	A1	9/2005	Scirica et al.
2004/0181219	A1	9/2004	Goble et al.	2005/0222587	A1	10/2005	Jinno et al.
2004/0193189	A1	9/2004	Kortenbach et al.	2005/0222611	A1	10/2005	Weitkamp
2004/0197367	A1	10/2004	Rezania et al.	2005/0222616	A1	10/2005	Rethy et al.
2004/0199181	A1	10/2004	Knodel et al.	2005/0222665	A1	10/2005	Aranyi
2004/0204735	A1	10/2004	Shiroff et al.	2005/0228224	A1	10/2005	Okada et al.
2004/0218451	A1	11/2004	Said et al.	2005/0228446	A1	10/2005	Mooradian et al.
2004/0222268	A1	11/2004	Bilotti et al.	2005/0230453	A1	10/2005	Viola
2004/0225186	A1	11/2004	Horne et al.	2005/0240178	A1	10/2005	Morley et al.
2004/0232201	A1	11/2004	Wenchell et al.	2005/0242950	A1	11/2005	Lindsay et al.
2004/0236352	A1	11/2004	Wang et al.	2005/0245965	A1	11/2005	Orban, III et al.
2004/0239582	A1	12/2004	Seymour	2005/0246881	A1	11/2005	Kelly et al.
2004/0243147	A1	12/2004	Lipow	2005/0251063	A1	11/2005	Basude
2004/0243151	A1	12/2004	Demmy et al.	2005/0256452	A1	11/2005	DeMarchi et al.
2004/0243163	A1	12/2004	Casiano et al.	2005/0256546	A1	11/2005	Vaisnys et al.
2004/0247415	A1	12/2004	Mangone	2005/0258963	A1	11/2005	Rodriguez et al.
2004/0249366	A1	12/2004	Kunz	2005/0261676	A1	11/2005	Hall et al.
2004/0254455	A1	12/2004	Iddan	2005/0263563	A1	12/2005	Racenet et al.
2004/0254566	A1	12/2004	Plicchi et al.	2005/0267455	A1	12/2005	Eggers et al.
2004/0254590	A1	12/2004	Hoffman et al.	2005/0274034	A1	12/2005	Hayashida et al.
2004/0254680	A1	12/2004	Sunaoshi	2005/0283188	A1	12/2005	Loshakove et al.
2004/0260315	A1	12/2004	Deli et al.	2005/0283226	A1	12/2005	Haverkost
2004/0267310	A1	12/2004	Racenet et al.	2006/0008787	A1	1/2006	Hayman et al.
2005/0010158	A1	1/2005	Brugger et al.	2006/0015009	A1	1/2006	Jaffe et al.
2005/0010213	A1	1/2005	Stad et al.	2006/0020167	A1	1/2006	Sitzmann
				2006/0020258	A1	1/2006	Strauss et al.
				2006/0020336	A1	1/2006	Liddicoat
				2006/0025812	A1	2/2006	Shelton
				2006/0041188	A1	2/2006	Dirusso et al.

(56)

References Cited

U.S. PATENT DOCUMENTS

2006/0047275	A1	3/2006	Goble	2007/0078484	A1	4/2007	Talarico et al.
2006/0049229	A1	3/2006	Milliman et al.	2007/0084897	A1	4/2007	Shelton et al.
2006/0052824	A1	3/2006	Ransick et al.	2007/0088376	A1	4/2007	Zacharias
2006/0052825	A1	3/2006	Ransick et al.	2007/0090788	A1	4/2007	Hansford et al.
2006/0064086	A1	3/2006	Odom	2007/0093869	A1	4/2007	Bloom et al.
2006/0079735	A1	4/2006	Martone et al.	2007/0102472	A1	5/2007	Shelton
2006/0079874	A1	4/2006	Faller et al.	2007/0103437	A1	5/2007	Rosenberg
2006/0079879	A1	4/2006	Faller et al.	2007/0106113	A1	5/2007	Ravo
2006/0086032	A1	4/2006	Valencic et al.	2007/0106317	A1	5/2007	Shelton et al.
2006/0087746	A1	4/2006	Lipow	2007/0118115	A1	5/2007	Artale et al.
2006/0089535	A1	4/2006	Raz et al.	2007/0134251	A1	6/2007	Ashkenazi et al.
2006/0097699	A1	5/2006	Kamenoff	2007/0135686	A1	6/2007	Pruitt et al.
2006/0100643	A1	5/2006	Lauffer et al.	2007/0135803	A1	6/2007	Belson
2006/0100649	A1	5/2006	Hart	2007/0152612	A1	7/2007	Chen et al.
2006/0106369	A1	5/2006	Desai et al.	2007/0152829	A1	7/2007	Lindsay et al.
2006/0111711	A1	5/2006	Goble	2007/0155010	A1	7/2007	Farnsworth et al.
2006/0111723	A1	5/2006	Chapolini et al.	2007/0170225	A1	7/2007	Shelton et al.
2006/0116634	A1	6/2006	Shachar	2007/0173687	A1	7/2007	Shima et al.
2006/0142772	A1	6/2006	Ralph et al.	2007/0173813	A1	7/2007	Odom
2006/0144898	A1	7/2006	Bilotti et al.	2007/0173872	A1	7/2007	Neuenfeldt
2006/0154546	A1	7/2006	Murphy et al.	2007/0175950	A1	8/2007	Shelton et al.
2006/0161050	A1	7/2006	Butler et al.	2007/0175951	A1	8/2007	Shelton et al.
2006/0161185	A1	7/2006	Saadat et al.	2007/0175955	A1	8/2007	Shelton et al.
2006/0167471	A1	7/2006	Phillips	2007/0179477	A1	8/2007	Danger
2006/0173290	A1	8/2006	Lavallee et al.	2007/0185545	A1	8/2007	Duke
2006/0173470	A1	8/2006	Oray et al.	2007/0187857	A1	8/2007	Riley et al.
2006/0176031	A1	8/2006	Forman et al.	2007/0190110	A1	8/2007	Pameijer et al.
2006/0176242	A1	8/2006	Jaramaz et al.	2007/0191868	A1	8/2007	Theroux et al.
2006/0178556	A1	8/2006	Hasser et al.	2007/0191915	A1	8/2007	Strother et al.
2006/0180633	A1	8/2006	Emmons	2007/0194079	A1	8/2007	Hueil et al.
2006/0180634	A1	8/2006	Shelton et al.	2007/0194082	A1	8/2007	Morgan et al.
2006/0185682	A1	8/2006	Marczyk	2007/0197954	A1	8/2007	Keenan
2006/0199999	A1	9/2006	Ikeda et al.	2007/0198039	A1	8/2007	Jones et al.
2006/0201989	A1	9/2006	Ojeda	2007/0203510	A1	8/2007	Bettuchi
2006/0206100	A1	9/2006	Eskridge et al.	2007/0207010	A1	9/2007	Caspi
2006/0217729	A1	9/2006	Eskridge et al.	2007/0208359	A1	9/2007	Hoffman
2006/0226957	A1	10/2006	Miller et al.	2007/0208375	A1	9/2007	Nishizawa et al.
2006/0235368	A1	10/2006	Oz	2007/0213750	A1	9/2007	Weadock
2006/0241666	A1	10/2006	Briggs et al.	2007/0225562	A1	9/2007	Spivey et al.
2006/0244460	A1	11/2006	Weaver	2007/0233163	A1	10/2007	Bombard et al.
2006/0247584	A1	11/2006	Sheetz et al.	2007/0243227	A1	10/2007	Gertner
2006/0252981	A1	11/2006	Matsuda et al.	2007/0244471	A1	10/2007	Malackowski
2006/0252990	A1	11/2006	Kubach	2007/0244496	A1	10/2007	Hellenkamp
2006/0252993	A1	11/2006	Freed et al.	2007/0246505	A1	10/2007	Pace-Florida et al.
2006/0258904	A1	11/2006	Stefanchik et al.	2007/0260132	A1	11/2007	Sterling
2006/0259073	A1	11/2006	Miyamoto et al.	2007/0262592	A1	11/2007	Hwang et al.
2006/0261763	A1	11/2006	Iott et al.	2007/0270660	A1	11/2007	Caylor et al.
2006/0263444	A1	11/2006	Ming et al.	2007/0275035	A1	11/2007	Herman et al.
2006/0264831	A1	11/2006	Skwarek et al.	2007/0276409	A1	11/2007	Ortiz et al.
2006/0264929	A1	11/2006	Goble et al.	2007/0279011	A1	12/2007	Jones et al.
2006/0271042	A1	11/2006	Latterell et al.	2007/0286892	A1	12/2007	Herzberg et al.
2006/0271102	A1	11/2006	Bosshard et al.	2007/0290027	A1	12/2007	Maatta et al.
2006/0282064	A1	12/2006	Shimizu et al.	2007/0296286	A1	12/2007	Avenell
2006/0284730	A1	12/2006	Schmid et al.	2008/0003196	A1	1/2008	Jonn et al.
2006/0287576	A1	12/2006	Tsuji et al.	2008/0015598	A1	1/2008	Prommersberger
2006/0289602	A1	12/2006	Wales et al.	2008/0021486	A1	1/2008	Oyola et al.
2006/0291981	A1	12/2006	Viola et al.	2008/0029570	A1	2/2008	Shelton et al.
2007/0005045	A1	1/2007	Mintz et al.	2008/0029573	A1	2/2008	Shelton et al.
2007/0009570	A1	1/2007	Kim et al.	2008/0029574	A1	2/2008	Shelton et al.
2007/0010702	A1	1/2007	Wang et al.	2008/0029575	A1	2/2008	Shelton et al.
2007/0010838	A1	1/2007	Shelton et al.	2008/0030170	A1	2/2008	Dacquay et al.
2007/0016235	A1	1/2007	Tanaka et al.	2008/0039746	A1	2/2008	Hissong et al.
2007/0018958	A1	1/2007	Tavakoli et al.	2008/0042861	A1	2/2008	Dacquay et al.
2007/0026039	A1	2/2007	Drumheller et al.	2008/0051833	A1	2/2008	Gramuglia et al.
2007/0026040	A1	2/2007	Crawley et al.	2008/0064920	A1	3/2008	Bakos et al.
2007/0027468	A1	2/2007	Wales et al.	2008/0064921	A1	3/2008	Larkin et al.
2007/0027551	A1	2/2007	Farnsworth et al.	2008/0065153	A1	3/2008	Allard et al.
2007/0043387	A1	2/2007	Vargas et al.	2008/0069736	A1	3/2008	Mingerink et al.
2007/0049951	A1	3/2007	Menn	2008/0071328	A1	3/2008	Haubrich et al.
2007/0049966	A1	3/2007	Bonadio et al.	2008/0077158	A1	3/2008	Haider et al.
2007/0051375	A1	3/2007	Milliman	2008/0078802	A1	4/2008	Hess et al.
2007/0055228	A1	3/2007	Berg et al.	2008/0081948	A1	4/2008	Weisenburgh et al.
2007/0073341	A1	3/2007	Smith et al.	2008/0082114	A1	4/2008	McKenna et al.
2007/0073389	A1	3/2007	Bolduc et al.	2008/0082125	A1	4/2008	Murray et al.
2007/0078328	A1	4/2007	Ozaki et al.	2008/0082126	A1	4/2008	Murray et al.
				2008/0083807	A1	4/2008	Beardsley et al.
				2008/0083811	A1	4/2008	Marczyk
				2008/0085296	A1	4/2008	Powell et al.
				2008/0086078	A1	4/2008	Powell et al.

(56)

References Cited

U.S. PATENT DOCUMENTS

2008/0091072	A1	4/2008	Omori et al.	2009/0132400	A1	5/2009	Conway
2008/0108443	A1	5/2008	Jinno et al.	2009/0135280	A1	5/2009	Johnston et al.
2008/0114250	A1	5/2008	Urbano et al.	2009/0143855	A1	6/2009	Weber et al.
2008/0125634	A1	5/2008	Ryan et al.	2009/0149871	A9	6/2009	Kagan et al.
2008/0125749	A1	5/2008	Olson	2009/0171147	A1	7/2009	Lee et al.
2008/0128469	A1	6/2008	Dalessandro et al.	2009/0177218	A1	7/2009	Young et al.
2008/0129253	A1	6/2008	Shiue et al.	2009/0177226	A1	7/2009	Reinprecht et al.
2008/0135600	A1	6/2008	Hiranuma et al.	2009/0181290	A1	7/2009	Baldwin et al.
2008/0140115	A1	6/2008	Stopek	2009/0188964	A1	7/2009	Orlov
2008/0140159	A1	6/2008	Bornhoft et al.	2009/0192534	A1	7/2009	Ortiz et al.
2008/0149682	A1	6/2008	Uhm	2009/0198272	A1	8/2009	Kerver et al.
2008/0154299	A1	6/2008	Livneh	2009/0204108	A1	8/2009	Steffen
2008/0154335	A1	6/2008	Thrope et al.	2009/0204109	A1	8/2009	Grove et al.
2008/0169328	A1	7/2008	Shelton	2009/0206125	A1	8/2009	Huitema et al.
2008/0169332	A1	7/2008	Shelton et al.	2009/0206126	A1	8/2009	Huitema et al.
2008/0169333	A1	7/2008	Shelton et al.	2009/0206131	A1	8/2009	Weisenburgh, II et al.
2008/0172087	A1	7/2008	Fuchs et al.	2009/0206133	A1	8/2009	Morgan et al.
2008/0177392	A1	7/2008	Williams et al.	2009/0206137	A1	8/2009	Hall et al.
2008/0190989	A1	8/2008	Crews et al.	2009/0206139	A1	8/2009	Hall et al.
2008/0196253	A1	8/2008	Ezra et al.	2009/0206141	A1	8/2009	Huitema et al.
2008/0196419	A1	8/2008	Dube	2009/0206142	A1	8/2009	Huitema et al.
2008/0197167	A1	8/2008	Viola et al.	2009/0221993	A1	9/2009	Sohi et al.
2008/0200755	A1	8/2008	Bakos	2009/0227834	A1	9/2009	Nakamoto et al.
2008/0200762	A1	8/2008	Stokes et al.	2009/0234273	A1	9/2009	Intoccia et al.
2008/0200835	A1	8/2008	Monson et al.	2009/0242610	A1	10/2009	Shelton, IV et al.
2008/0200911	A1	8/2008	Long	2009/0246873	A1	10/2009	Yamamoto et al.
2008/0200933	A1	8/2008	Bakos et al.	2009/0247368	A1	10/2009	Chiang
2008/0200934	A1	8/2008	Fox	2009/0247901	A1	10/2009	Zimmer
2008/0206186	A1	8/2008	Butler et al.	2009/0248100	A1	10/2009	Vaisnys et al.
2008/0208058	A1	8/2008	Sabata et al.	2009/0253959	A1	10/2009	Yoshie et al.
2008/0234709	A1	9/2008	Houser	2009/0255974	A1	10/2009	Viola
2008/0234866	A1	9/2008	Kishi et al.	2009/0261141	A1	10/2009	Stratton et al.
2008/0242939	A1	10/2008	Johnston	2009/0262078	A1	10/2009	Pizzi
2008/0243088	A1	10/2008	Evans	2009/0270895	A1	10/2009	Churchill et al.
2008/0249536	A1	10/2008	Stahler et al.	2009/0273353	A1	11/2009	Kroh et al.
2008/0249608	A1	10/2008	Dave	2009/0277288	A1*	11/2009	Doepker A61B 17/07207 73/865.8
2008/0255413	A1	10/2008	Zemlok et al.	2009/0278406	A1	11/2009	Hoffman
2008/0255420	A1	10/2008	Lee et al.	2009/0290016	A1	11/2009	Suda
2008/0255663	A1	10/2008	Akpek et al.	2009/0292283	A1	11/2009	Odom
2008/0262654	A1	10/2008	Omori et al.	2009/0306639	A1	12/2009	Nevo et al.
2008/0269596	A1	10/2008	Revie et al.	2009/0308907	A1	12/2009	Nalagatla et al.
2008/0281171	A1	11/2008	Fennell et al.	2009/0318557	A1	12/2009	Stockel
2008/0281332	A1	11/2008	Taylor	2009/0325859	A1	12/2009	Ameer et al.
2008/0287944	A1	11/2008	Pearson et al.	2010/0005035	A1	1/2010	Carpenter et al.
2008/0293910	A1	11/2008	Kapiamba et al.	2010/0012703	A1	1/2010	Calabrese et al.
2008/0294179	A1	11/2008	Balbierz et al.	2010/0015104	A1	1/2010	Fraser et al.
2008/0296346	A1	12/2008	Shelton, IV et al.	2010/0016853	A1	1/2010	Burbank
2008/0297287	A1	12/2008	Shachar et al.	2010/0016888	A1	1/2010	Calabrese et al.
2008/0298784	A1	12/2008	Kastner	2010/0017715	A1	1/2010	Balassanian
2008/0308602	A1	12/2008	Timm et al.	2010/0023024	A1	1/2010	Zeiner et al.
2008/0308603	A1	12/2008	Shelton et al.	2010/0030233	A1	2/2010	Whitman et al.
2008/0312686	A1	12/2008	Ellingwood	2010/0030239	A1	2/2010	Viola et al.
2008/0312687	A1	12/2008	Blier	2010/0032179	A1	2/2010	Hanspers et al.
2008/0315829	A1	12/2008	Jones et al.	2010/0036370	A1	2/2010	Mirel et al.
2009/0001121	A1	1/2009	Hess et al.	2010/0051668	A1	3/2010	Milliman et al.
2009/0001130	A1	1/2009	Hess et al.	2010/0057118	A1	3/2010	Dietz et al.
2009/0004455	A1	1/2009	Gravagna et al.	2010/0065604	A1	3/2010	Weng
2009/0005809	A1	1/2009	Hess et al.	2010/0069833	A1	3/2010	Wenderow et al.
2009/0012534	A1	1/2009	Madhani et al.	2010/0069942	A1	3/2010	Shelton, IV
2009/0015195	A1	1/2009	Loth-Krausser	2010/0076483	A1	3/2010	Imuta
2009/0020958	A1	1/2009	Soul	2010/0076489	A1	3/2010	Stopek et al.
2009/0048583	A1	2/2009	Williams et al.	2010/0081883	A1	4/2010	Murray et al.
2009/0048589	A1	2/2009	Takashino et al.	2010/0094340	A1	4/2010	Stopek et al.
2009/0076506	A1	3/2009	Baker	2010/0094400	A1	4/2010	Bolduc et al.
2009/0078736	A1	3/2009	Van Lue	2010/0100123	A1	4/2010	Bennett
2009/0081313	A1	3/2009	Aghion et al.	2010/0100124	A1	4/2010	Calabrese et al.
2009/0088659	A1	4/2009	Graham et al.	2010/0116519	A1	5/2010	Gareis
2009/0090763	A1	4/2009	Zemlok et al.	2010/0122339	A1	5/2010	Boccacci
2009/0099579	A1	4/2009	Nentwick et al.	2010/0133317	A1	6/2010	Shelton, IV et al.
2009/0099876	A1	4/2009	Whitman	2010/0137990	A1	6/2010	Apatsidis et al.
2009/0110533	A1	4/2009	Jinno	2010/0138659	A1	6/2010	Carmichael et al.
2009/0112234	A1	4/2009	Crainich et al.	2010/0145146	A1	6/2010	Melder
2009/0118762	A1	5/2009	Crainch et al.	2010/0147921	A1	6/2010	Olson
2009/0119011	A1	5/2009	Kondo et al.	2010/0147922	A1	6/2010	Olson
2009/0131819	A1	5/2009	Ritchie et al.	2010/0159435	A1	6/2010	Mueller et al.
				2010/0179022	A1	7/2010	Shirokoshi
				2010/0180711	A1	7/2010	Kilibarda et al.
				2010/0191262	A1	7/2010	Harris et al.

(56)

References Cited

U.S. PATENT DOCUMENTS

2010/0191292	A1	7/2010	DeMeo et al.	2011/0271186	A1	11/2011	Owens
2010/0193566	A1	8/2010	Scheib et al.	2011/0275901	A1	11/2011	Shelton, IV
2010/0204717	A1	8/2010	Knodel	2011/0276083	A1	11/2011	Shelton, IV et al.
2010/0204721	A1	8/2010	Young et al.	2011/0278343	A1	11/2011	Knodel et al.
2010/0217281	A1	8/2010	Matsuoka et al.	2011/0279268	A1	11/2011	Konishi et al.
2010/0222901	A1	9/2010	Swayze et al.	2011/0285507	A1	11/2011	Nelson
2010/0228250	A1	9/2010	Brogna	2011/0290856	A1	12/2011	Shelton, IV et al.
2010/0234687	A1	9/2010	Azarbarzin et al.	2011/0290858	A1	12/2011	Whitman et al.
2010/0241137	A1	9/2010	Doyle et al.	2011/0292258	A1	12/2011	Adler et al.
2010/0245102	A1	9/2010	Yokoi	2011/0293690	A1	12/2011	Griffin et al.
2010/0249497	A1	9/2010	Peine et al.	2011/0295295	A1	12/2011	Shelton, IV et al.
2010/0249947	A1	9/2010	Lesh et al.	2011/0313894	A1	12/2011	Dye et al.
2010/0256675	A1	10/2010	Romans	2011/0315413	A1	12/2011	Fisher et al.
2010/0258327	A1	10/2010	Esenwein et al.	2012/0004636	A1	1/2012	Lo
2010/0267662	A1	10/2010	Fielder et al.	2012/0007442	A1	1/2012	Rhodes et al.
2010/0274160	A1	10/2010	Yachi et al.	2012/0008880	A1	1/2012	Toth
2010/0291184	A1	11/2010	Clark et al.	2012/0016239	A1	1/2012	Barthe et al.
2010/0292540	A1	11/2010	Hess et al.	2012/0016413	A1	1/2012	Timm et al.
2010/0298636	A1	11/2010	Castro et al.	2012/0016467	A1	1/2012	Chen et al.
2010/0301097	A1	12/2010	Scirica et al.	2012/0029272	A1	2/2012	Shelton, IV et al.
2010/0310623	A1	12/2010	Laurencin et al.	2012/0033360	A1	2/2012	Hsu
2010/0312261	A1	12/2010	Suzuki et al.	2012/0059286	A1	3/2012	Hastings et al.
2010/0318085	A1	12/2010	Austin et al.	2012/0064483	A1	3/2012	Lint et al.
2010/0331856	A1	12/2010	Carlson et al.	2012/0074200	A1	3/2012	Schmid et al.
2011/0006101	A1	1/2011	Hall et al.	2012/0078243	A1	3/2012	Worrell et al.
2011/0009694	A1	1/2011	Schultz et al.	2012/0078244	A1	3/2012	Worrell et al.
2011/0011916	A1	1/2011	Levine	2012/0080336	A1	4/2012	Shelton, IV et al.
2011/0016960	A1	1/2011	Debrailly	2012/0080344	A1	4/2012	Shelton, IV
2011/0021871	A1	1/2011	Berkelaar	2012/0080478	A1	4/2012	Morgan et al.
2011/0022032	A1	1/2011	Zemlok et al.	2012/0080498	A1	4/2012	Shelton, IV et al.
2011/0024477	A1	2/2011	Hall	2012/0086276	A1	4/2012	Sawyers
2011/0024478	A1	2/2011	Shelton, IV	2012/0095458	A1	4/2012	Cybulski et al.
2011/0025311	A1	2/2011	Chauvin et al.	2012/0109186	A1	5/2012	Parrott et al.
2011/0028991	A1	2/2011	Ikeda et al.	2012/0116261	A1	5/2012	Mumaw et al.
2011/0029270	A1	2/2011	Mueglitz	2012/0116262	A1	5/2012	Houser et al.
2011/0036891	A1	2/2011	Zemlok et al.	2012/0116265	A1	5/2012	Houser et al.
2011/0046667	A1	2/2011	Culligan et al.	2012/0116266	A1	5/2012	Houser et al.
2011/0052660	A1	3/2011	Yang et al.	2012/0116381	A1	5/2012	Houser et al.
2011/0056717	A1	3/2011	Herisse	2012/0118595	A1	5/2012	Pellenc
2011/0060363	A1	3/2011	Hess et al.	2012/0123463	A1	5/2012	Jacobs
2011/0066156	A1	3/2011	McGahan et al.	2012/0125792	A1	5/2012	Cassivi
2011/0082538	A1	4/2011	Dahlgren et al.	2012/0130217	A1	5/2012	Kauphusman et al.
2011/0087276	A1	4/2011	Bedi et al.	2012/0132286	A1	5/2012	Lim et al.
2011/0088921	A1	4/2011	Forgues et al.	2012/0171539	A1	7/2012	Rejman et al.
2011/0091515	A1	4/2011	Zilberman et al.	2012/0175398	A1	7/2012	Sandborn et al.
2011/0095064	A1	4/2011	Taylor et al.	2012/0190964	A1	7/2012	Hyde et al.
2011/0095067	A1	4/2011	Ohdaira	2012/0197239	A1	8/2012	Smith et al.
2011/0101069	A1	5/2011	Bombard et al.	2012/0197272	A1	8/2012	Oray et al.
2011/0101794	A1	5/2011	Schroeder et al.	2012/0211542	A1	8/2012	Racenet
2011/0112517	A1	5/2011	Peine et al.	2012/0220990	A1	8/2012	Mckenzie et al.
2011/0112530	A1	5/2011	Keller	2012/0234895	A1	9/2012	O'Connor et al.
2011/0114697	A1	5/2011	Baxter, III et al.	2012/0234897	A1	9/2012	Shelton, IV et al.
2011/0118708	A1	5/2011	Burbank et al.	2012/0239068	A1	9/2012	Morris et al.
2011/0125149	A1	5/2011	El-Galley et al.	2012/0248169	A1	10/2012	Widenhouse et al.
2011/0125176	A1	5/2011	Yates et al.	2012/0251861	A1	10/2012	Liang et al.
2011/0127945	A1	6/2011	Yoneda	2012/0253328	A1	10/2012	Cunningham et al.
2011/0129706	A1	6/2011	Takahashi et al.	2012/0271327	A1	10/2012	West et al.
2011/0144764	A1	6/2011	Bagga et al.	2012/0283707	A1	11/2012	Giordano et al.
2011/0147433	A1	6/2011	Shelton, IV et al.	2012/0289811	A1	11/2012	Viola et al.
2011/0160725	A1	6/2011	Kabaya et al.	2012/0289979	A1	11/2012	Eskaros et al.
2011/0163146	A1	7/2011	Ortiz et al.	2012/0292367	A1	11/2012	Morgan et al.
2011/0172495	A1	7/2011	Armstrong	2012/0296316	A1	11/2012	Imuta
2011/0174861	A1	7/2011	Shelton, IV et al.	2012/0296342	A1	11/2012	Haglund Wendelschafer
2011/0192882	A1	8/2011	Hess et al.	2012/0298722	A1	11/2012	Hess et al.
2011/0199225	A1	8/2011	Touchberry et al.	2012/0301498	A1	11/2012	Altreuter et al.
2011/0218400	A1	9/2011	Ma et al.	2012/0316424	A1	12/2012	Stopek
2011/0218550	A1	9/2011	Ma	2012/0330329	A1	12/2012	Harris et al.
2011/0220381	A1	9/2011	Friese et al.	2013/0006227	A1	1/2013	Takashino
2011/0225105	A1	9/2011	Scholer et al.	2013/0008937	A1	1/2013	Viola
2011/0230713	A1	9/2011	Kleemann et al.	2013/0012983	A1	1/2013	Kleyman
2011/0235168	A1	9/2011	Sander	2013/0018400	A1	1/2013	Milton et al.
2011/0238044	A1	9/2011	Main et al.	2013/0020375	A1	1/2013	Shelton, IV et al.
2011/0241597	A1	10/2011	Zhu et al.	2013/0020376	A1	1/2013	Shelton, IV et al.
2011/0251606	A1	10/2011	Kerr	2013/0023861	A1	1/2013	Shelton, IV et al.
2011/0256266	A1	10/2011	Orme et al.	2013/0023910	A1	1/2013	Solomon et al.
				2013/0026208	A1	1/2013	Shelton, IV et al.
				2013/0026210	A1	1/2013	Shelton, IV et al.
				2013/0030462	A1	1/2013	Keating et al.
				2013/0041292	A1	2/2013	Cunningham

(56)

References Cited

U.S. PATENT DOCUMENTS

2013/0057162 A1	3/2013	Pollischansky	2014/0166725 A1	6/2014	Schellin et al.
2013/0068816 A1	3/2013	Mandakolathur Vasudevan et al.	2014/0166726 A1	6/2014	Schellin et al.
2013/0075447 A1	3/2013	Weisenburgh, II et al.	2014/0175147 A1	6/2014	Manoux et al.
2013/0087597 A1	4/2013	Shelton, IV et al.	2014/0175150 A1	6/2014	Shelton, IV et al.
2013/0090534 A1	4/2013	Burns et al.	2014/0175152 A1	6/2014	Hess et al.
2013/0096568 A1	4/2013	Justis	2014/0181710 A1	6/2014	Baalu et al.
2013/0098970 A1	4/2013	Racenet et al.	2014/0183244 A1	7/2014	Duque et al.
2013/0106352 A1	5/2013	Nagamine	2014/0188091 A1	7/2014	Vidal et al.
2013/0112729 A1	5/2013	Beardsley et al.	2014/0188159 A1	7/2014	Steege
2013/0116669 A1	5/2013	Shelton, IV et al.	2014/0207124 A1	7/2014	Aldridge et al.
2013/0123816 A1	5/2013	Hodgkinson et al.	2014/0209658 A1	7/2014	Skalla et al.
2013/0126202 A1	5/2013	Oomori et al.	2014/0224857 A1	8/2014	Schmid
2013/0131476 A1	5/2013	Siu et al.	2014/0228632 A1	8/2014	Sholev et al.
2013/0131651 A1	5/2013	Strobl et al.	2014/0228867 A1	8/2014	Thomas et al.
2013/0136969 A1	5/2013	Yasui et al.	2014/0239047 A1	8/2014	Hodgkinson et al.
2013/0153641 A1	6/2013	Shelton, IV et al.	2014/0243865 A1	8/2014	Swayze et al.
2013/0158390 A1	6/2013	Tan et al.	2014/0246475 A1	9/2014	Hall et al.
2013/0162198 A1	6/2013	Yokota et al.	2014/0248167 A1	9/2014	Sugimoto et al.
2013/0169217 A1	7/2013	Watanabe et al.	2014/0249557 A1	9/2014	Koch et al.
2013/0172713 A1	7/2013	Kirschenman	2014/0249573 A1	9/2014	Arav
2013/0172878 A1	7/2013	Smith	2014/0262408 A1	9/2014	Woodard
2013/0175317 A1	7/2013	Yates et al.	2014/0263541 A1	9/2014	Leimbach et al.
2013/0183769 A1	7/2013	Tajima	2014/0263552 A1	9/2014	Hall et al.
2013/0211244 A1	8/2013	Nathaniel	2014/0263558 A1	9/2014	Hausen et al.
2013/0214025 A1	8/2013	Zemlok et al.	2014/0263570 A1*	9/2014	Hopkins A61B 17/07207 227/180.1
2013/0215449 A1	8/2013	Yamasaki	2014/0276730 A1	9/2014	Boudreaux et al.
2013/0231681 A1	9/2013	Robinson et al.	2014/0284371 A1	9/2014	Morgan et al.
2013/0233906 A1	9/2013	Hess et al.	2014/0288460 A1	9/2014	Ouyang et al.
2013/0238021 A1	9/2013	Gross et al.	2014/0291379 A1	10/2014	Schellin et al.
2013/0248578 A1	9/2013	Arteaga Gonzalez	2014/0291383 A1	10/2014	Spivey et al.
2013/0253480 A1	9/2013	Kimball et al.	2014/0299648 A1	10/2014	Shelton, IV et al.
2013/0256373 A1	10/2013	Schmid et al.	2014/0303645 A1	10/2014	Morgan et al.
2013/0256380 A1	10/2013	Schmid et al.	2014/0303660 A1	10/2014	Boyden et al.
2013/0267978 A1	10/2013	Trissel	2014/0330161 A1	11/2014	Swayze et al.
2013/0270322 A1	10/2013	Scheib et al.	2014/0330298 A1	11/2014	Arshonsky et al.
2013/0277410 A1	10/2013	Fernandez et al.	2014/0330579 A1	11/2014	Cashman et al.
2013/0284792 A1	10/2013	Ma	2014/0358163 A1	12/2014	Farin et al.
2013/0293353 A1	11/2013	McPherson et al.	2014/0367445 A1	12/2014	Ingmanson et al.
2013/0303845 A1	11/2013	Skula et al.	2014/0374130 A1	12/2014	Nakamura et al.
2013/0306704 A1	11/2013	Balbierz et al.	2014/0378950 A1	12/2014	Chiu
2013/0327552 A1	12/2013	Lovelass et al.	2015/0001272 A1	1/2015	Sniffin et al.
2013/0333910 A1	12/2013	Tanimoto et al.	2015/0002089 A1	1/2015	Rejman et al.
2013/0334280 A1	12/2013	Krehel et al.	2015/0025549 A1	1/2015	Kilroy et al.
2013/0334283 A1	12/2013	Swayze et al.	2015/0025571 A1	1/2015	Suzuki et al.
2013/0334285 A1	12/2013	Swayze et al.	2015/0039010 A1	2/2015	Beardsley et al.
2013/0341374 A1	12/2013	Shelton, IV et al.	2015/0053737 A1	2/2015	Leimbach et al.
2014/0001231 A1	1/2014	Shelton, IV et al.	2015/0053743 A1	2/2015	Yates et al.
2014/0001234 A1	1/2014	Shelton, IV et al.	2015/0053746 A1	2/2015	Shelton, IV et al.
2014/0005640 A1	1/2014	Shelton, IV et al.	2015/0053748 A1	2/2015	Yates et al.
2014/0005678 A1	1/2014	Shelton, IV et al.	2015/0060519 A1	3/2015	Shelton, IV et al.
2014/0005702 A1	1/2014	Timm et al.	2015/0060520 A1	3/2015	Shelton, IV et al.
2014/0005718 A1	1/2014	Shelton, IV et al.	2015/0060521 A1	3/2015	Weisenburgh, II et al.
2014/0008289 A1	1/2014	Williams et al.	2015/0066000 A1	3/2015	An et al.
2014/0014704 A1	1/2014	Onukuri et al.	2015/0076208 A1	3/2015	Shelton, IV
2014/0014705 A1	1/2014	Baxter, III	2015/0076209 A1	3/2015	Shelton, IV et al.
2014/0014707 A1	1/2014	Onukuri et al.	2015/0076210 A1	3/2015	Shelton, IV et al.
2014/0018832 A1	1/2014	Shelton, IV	2015/0076211 A1	3/2015	Irka et al.
2014/0022283 A1	1/2014	Chan et al.	2015/0082624 A1	3/2015	Craig et al.
2014/0039549 A1	2/2014	Belsky et al.	2015/0083781 A1	3/2015	Giordano et al.
2014/0041191 A1*	2/2014	Knodel A61B 17/07207 29/428	2015/0087952 A1	3/2015	Albert et al.
2014/0048580 A1	2/2014	Merchant et al.	2015/0088127 A1	3/2015	Craig et al.
2014/0078715 A1	3/2014	Pickard et al.	2015/0088547 A1	3/2015	Balram et al.
2014/0081176 A1	3/2014	Hassan	2015/0090760 A1	4/2015	Giordano et al.
2014/0094681 A1	4/2014	Valentine et al.	2015/0090762 A1	4/2015	Giordano et al.
2014/0100558 A1	4/2014	Schmitz et al.	2015/0127021 A1	5/2015	Harris et al.
2014/0107697 A1	4/2014	Patani et al.	2015/0134077 A1	5/2015	Shelton, IV et al.
2014/0115229 A1	4/2014	Kothamasu et al.	2015/0150620 A1	6/2015	Miyamoto et al.
2014/0131418 A1	5/2014	Kostrzewski	2015/0173749 A1	6/2015	Shelton, IV et al.
2014/0135832 A1	5/2014	Park et al.	2015/0173756 A1	6/2015	Baxter, III et al.
2014/0151433 A1	6/2014	Shelton, IV et al.	2015/0173789 A1	6/2015	Baxter, III et al.
2014/0155916 A1	6/2014	Hodgkinson et al.	2015/0196295 A1	7/2015	Shelton, IV et al.
2014/0158747 A1	6/2014	Measamer et al.	2015/0196296 A1	7/2015	Swayze et al.
2014/0166723 A1	6/2014	Beardsley et al.	2015/0196299 A1	7/2015	Swayze et al.
2014/0166724 A1	6/2014	Schellin et al.	2015/0196347 A1*	7/2015	Yates A61B 17/320016 606/48
			2015/0201918 A1	7/2015	Kumar et al.
			2015/0201932 A1	7/2015	Swayze et al.
			2015/0201936 A1	7/2015	Swayze et al.

(56)

References Cited

U.S. PATENT DOCUMENTS

2018/0132952	A1	5/2018	Spivey et al.	2019/0038279	A1	2/2019	Shelton, IV et al.
2018/0133521	A1	5/2018	Frushour et al.	2019/0038281	A1	2/2019	Shelton, IV et al.
2018/0140299	A1	5/2018	Weaner et al.	2019/0038282	A1	2/2019	Shelton, IV et al.
2018/0146960	A1	5/2018	Shelton, IV et al.	2019/0038283	A1	2/2019	Shelton, IV et al.
2018/0153542	A1	6/2018	Shelton, IV et al.	2019/0038285	A1*	2/2019	Mozdzierz A61B 17/07207
2018/0153634	A1	6/2018	Zemlok et al.	2019/0059986	A1	2/2019	Shelton, IV et al.
2018/0168572	A1	6/2018	Burbank	2019/0076143	A1	3/2019	Smith
2018/0168574	A1*	6/2018	Robinson A61B 17/07207	2019/0090871	A1	3/2019	Shelton, IV et al.
2018/0168575	A1	6/2018	Simms et al.	2019/0091183	A1	3/2019	Tomat et al.
2018/0168577	A1	6/2018	Aronhalt et al.	2019/0099179	A1	4/2019	Leimbach et al.
2018/0168578	A1	6/2018	Aronhalt et al.	2019/0099181	A1	4/2019	Shelton, IV et al.
2018/0168579	A1	6/2018	Aronhalt et al.	2019/0099229	A1	4/2019	Spivey et al.
2018/0168590	A1	6/2018	Overmyer et al.	2019/0104919	A1	4/2019	Shelton, IV et al.
2018/0168592	A1	6/2018	Overmyer et al.	2019/0105035	A1	4/2019	Shelton, IV et al.
2018/0168598	A1	6/2018	Shelton, IV et al.	2019/0105036	A1	4/2019	Morgan et al.
2018/0168608	A1	6/2018	Shelton, IV et al.	2019/0105037	A1	4/2019	Morgan et al.
2018/0168609	A1	6/2018	Fanelli et al.	2019/0105039	A1	4/2019	Morgan et al.
2018/0168610	A1	6/2018	Shelton, IV et al.	2019/0105043	A1	4/2019	Jaworek et al.
2018/0168614	A1	6/2018	Shelton, IV et al.	2019/0105044	A1	4/2019	Shelton, IV et al.
2018/0168615	A1	6/2018	Shelton, IV et al.	2019/0110779	A1	4/2019	Gardner et al.
2018/0168618	A1	6/2018	Scott et al.	2019/0110791	A1	4/2019	Shelton, IV et al.
2018/0168619	A1	6/2018	Scott et al.	2019/0110792	A1	4/2019	Shelton, IV et al.
2018/0168623	A1	6/2018	Simms et al.	2019/0117224	A1	4/2019	Setser et al.
2018/0168625	A1	6/2018	Posada et al.	2019/0125320	A1	5/2019	Shelton, IV et al.
2018/0168633	A1	6/2018	Shelton, IV et al.	2019/0125321	A1	5/2019	Shelton, IV et al.
2018/0168647	A1	6/2018	Shelton, IV et al.	2019/0125335	A1	5/2019	Shelton, IV et al.
2018/0168648	A1	6/2018	Shelton, IV et al.	2019/0125336	A1	5/2019	Deck et al.
2018/0168650	A1	6/2018	Shelton, IV et al.	2019/0125338	A1	5/2019	Shelton, IV et al.
2018/0168754	A1	6/2018	Overmyer	2019/0125342	A1	5/2019	Beardsley et al.
2018/0228490	A1	8/2018	Richard et al.	2019/0125357	A1	5/2019	Shelton, IV et al.
2018/0235609	A1	8/2018	Harris et al.	2019/0125358	A1	5/2019	Shelton, IV et al.
2018/0236181	A1	8/2018	Marlin et al.	2019/0125359	A1	5/2019	Shelton, IV et al.
2018/0242970	A1	8/2018	Mozdzierz	2019/0125361	A1	5/2019	Shelton, IV et al.
2018/0271520	A1	9/2018	Shelton, IV et al.	2019/0125377	A1	5/2019	Shelton, IV
2018/0271604	A1	9/2018	Grout et al.	2019/0125378	A1	5/2019	Shelton, IV et al.
2018/0273597	A1	9/2018	Stimson	2019/0125387	A1	5/2019	Parihar et al.
2018/0289369	A1	10/2018	Shelton, IV et al.	2019/0125388	A1	5/2019	Shelton, IV et al.
2018/0289371	A1	10/2018	Wang et al.	2019/0125430	A1	5/2019	Shelton, IV et al.
2018/0296216	A1	10/2018	Shelton, IV et al.	2019/0125431	A1	5/2019	Shelton, IV et al.
2018/0296290	A1	10/2018	Namiki et al.	2019/0125432	A1	5/2019	Shelton, IV et al.
2018/0317905	A1	11/2018	Olson et al.	2019/0125454	A1	5/2019	Stokes et al.
2018/0333155	A1	11/2018	Hall et al.	2019/0125455	A1	5/2019	Shelton, IV et al.
2018/0333169	A1	11/2018	Leimbach et al.	2019/0125456	A1	5/2019	Shelton, IV et al.
2018/0353176	A1	12/2018	Shelton, IV et al.	2019/0125457	A1	5/2019	Parihar et al.
2018/0353177	A1	12/2018	Shelton, IV et al.	2019/0125458	A1	5/2019	Shelton, IV et al.
2018/0353179	A1	12/2018	Shelton, IV et al.	2019/0125459	A1	5/2019	Shelton, IV et al.
2018/0360446	A1	12/2018	Shelton, IV et al.	2019/0125476	A1	5/2019	Shelton, IV et al.
2018/0360456	A1	12/2018	Shelton, IV et al.	2019/0133422	A1	5/2019	Nakamura
2018/0360472	A1	12/2018	Harris et al.	2019/0138770	A1	5/2019	Compaijen et al.
2018/0360473	A1	12/2018	Shelton, IV et al.	2019/0142421	A1	5/2019	Shelton, IV
2018/0368066	A1	12/2018	Howell et al.	2019/0150925	A1	5/2019	Marczyk et al.
2018/0368833	A1	12/2018	Shelton, IV et al.	2019/0151029	A1	5/2019	Robinson
2018/0368839	A1	12/2018	Shelton, IV et al.	2019/0159778	A1	5/2019	Shelton, IV et al.
2018/0368843	A1	12/2018	Shelton, IV et al.	2019/0175847	A1	6/2019	Pocreva, III et al.
2018/0368844	A1	12/2018	Bakos et al.	2019/0183499	A1	6/2019	Shelton, IV et al.
2018/0372806	A1	12/2018	Laughery et al.	2019/0183502	A1	6/2019	Shelton, IV et al.
2019/0000459	A1	1/2019	Shelton, IV et al.	2019/0192138	A1	6/2019	Shelton, IV et al.
2019/0000461	A1	1/2019	Shelton, IV et al.	2019/0192141	A1	6/2019	Shelton, IV et al.
2019/0000462	A1	1/2019	Shelton, IV et al.	2019/0192146	A1	6/2019	Widenhouse et al.
2019/0000470	A1	1/2019	Yates et al.	2019/0192147	A1	6/2019	Shelton, IV et al.
2019/0000471	A1	1/2019	Shelton, IV et al.	2019/0192148	A1	6/2019	Shelton, IV et al.
2019/0000472	A1	1/2019	Shelton, IV et al.	2019/0192150	A1	6/2019	Widenhouse et al.
2019/0000474	A1	1/2019	Shelton, IV et al.	2019/0192151	A1	6/2019	Shelton, IV et al.
2019/0000475	A1	1/2019	Shelton, IV et al.	2019/0192152	A1	6/2019	Morgan et al.
2019/0000476	A1	1/2019	Shelton, IV et al.	2019/0192153	A1	6/2019	Shelton, IV et al.
2019/0000477	A1	1/2019	Shelton, IV et al.	2019/0192154	A1	6/2019	Shelton, IV et al.
2019/0000478	A1	1/2019	Messerly et al.	2019/0192155	A1	6/2019	Shelton, IV et al.
2019/0000481	A1	1/2019	Harris et al.	2019/0192156	A1	6/2019	Simms et al.
2019/0008515	A1	1/2019	Beardsley et al.	2019/0192157	A1	6/2019	Scott et al.
2019/0015102	A1	1/2019	Baber et al.	2019/0192158	A1	6/2019	Scott et al.
2019/0015165	A1	1/2019	Giordano et al.	2019/0192235	A1	6/2019	Harris et al.
2019/0021733	A1	1/2019	Burbank	2019/0192236	A1	6/2019	Shelton, IV et al.
2019/0029682	A1	1/2019	Huitema et al.	2019/0200844	A1	7/2019	Shelton, IV et al.
2019/0029701	A1	1/2019	Shelton, IV et al.	2019/0200863	A1	7/2019	Shelton, IV et al.
2019/0033955	A1	1/2019	Leimbach et al.	2019/0200905	A1	7/2019	Shelton, IV et al.
				2019/0200906	A1	7/2019	Shelton, IV et al.
				2019/0200977	A1	7/2019	Shelton, IV et al.
				2019/0200981	A1	7/2019	Harris et al.
				2019/0201023	A1	7/2019	Shelton, IV et al.

(56)

References Cited

U.S. PATENT DOCUMENTS

2020/0205811 A1 7/2020 Posey et al.
2020/0214706 A1 7/2020 Vendely et al.
2020/0214731 A1 7/2020 Shelton, IV et al.
2020/0222047 A1 7/2020 Shelton, IV et al.
2020/0229812 A1 7/2020 Parihar et al.
2020/0229814 A1 7/2020 Amariglio et al.
2020/0229816 A1 7/2020 Bakos et al.
2020/0237371 A1 7/2020 Huitema et al.
2020/0246001 A1 8/2020 Ming et al.
2020/0253605 A1 8/2020 Swayze et al.
2020/0261007 A1 8/2020 Lampropoulos et al.
2020/0261075 A1 8/2020 Boudreaux et al.
2020/0261076 A1 8/2020 Boudreaux et al.
2020/0261078 A1 8/2020 Bakos et al.
2020/0261080 A1 8/2020 Bakos et al.
2020/0261081 A1 8/2020 Boudreaux et al.
2020/0261082 A1 8/2020 Boudreaux et al.
2020/0261083 A1 8/2020 Bakos et al.
2020/0261084 A1 8/2020 Bakos et al.
2020/0261085 A1 8/2020 Boudreaux et al.
2020/0261086 A1 8/2020 Zeiner et al.
2020/0261087 A1 8/2020 Timm et al.
2020/0261088 A1 8/2020 Harris et al.
2020/0261089 A1 8/2020 Shelton, IV et al.
2020/0261106 A1 8/2020 Hess et al.
2020/0268377 A1 8/2020 Schmid et al.
2020/0268394 A1 8/2020 Parfett et al.
2020/0275926 A1 9/2020 Shelton, IV et al.
2020/0275927 A1 9/2020 Shelton, IV et al.
2020/0275928 A1 9/2020 Shelton, IV et al.
2020/0275930 A1 9/2020 Harris et al.
2020/0280219 A1 9/2020 Laughery et al.
2020/0281585 A1 9/2020 Timm et al.
2020/0281587 A1 9/2020 Schmid et al.
2020/0281590 A1 9/2020 Shelton, IV et al.
2020/0289112 A1 9/2020 Whitfield et al.
2020/0297340 A1 9/2020 Hess et al.
2020/0297341 A1 9/2020 Yates et al.
2020/0297346 A1 9/2020 Shelton, IV et al.
2020/0297438 A1 9/2020 Shelton, IV et al.
2020/0305862 A1 10/2020 Yates et al.
2020/0305863 A1 10/2020 Yates et al.
2020/0305864 A1 10/2020 Yates et al.
2020/0305868 A1 10/2020 Shelton, IV
2020/0305870 A1 10/2020 Shelton, IV
2020/0305871 A1 10/2020 Shelton, IV et al.
2020/0305872 A1 10/2020 Weidner et al.
2020/0305874 A1 10/2020 Huitema et al.
2020/0315612 A1 10/2020 Shelton, IV et al.
2020/0315625 A1 10/2020 Hall et al.
2020/0315983 A1 10/2020 Widenhouse et al.
2020/0323526 A1 10/2020 Huang et al.
2020/0330092 A1 10/2020 Shelton, IV et al.
2020/0330093 A1 10/2020 Shelton, IV et al.
2020/0330094 A1 10/2020 Baxter, III et al.
2020/0330096 A1 10/2020 Shelton, IV et al.
2020/0330181 A1 10/2020 Junger et al.
2020/0337693 A1 10/2020 Shelton, IV et al.
2020/0337702 A1 10/2020 Shelton, IV et al.
2020/0337703 A1 10/2020 Shelton, IV et al.
2020/0337791 A1 10/2020 Shelton, IV et al.
2020/0345346 A1 11/2020 Shelton, IV et al.
2020/0345349 A1 11/2020 Kimball et al.
2020/0345352 A1 11/2020 Shelton, IV et al.
2020/0345353 A1 11/2020 Leimbach et al.
2020/0345354 A1 11/2020 Leimbach et al.
2020/0345355 A1 11/2020 Baxter, III et al.
2020/0345356 A1 11/2020 Leimbach et al.
2020/0345357 A1 11/2020 Leimbach et al.
2020/0345358 A1 11/2020 Jenkins
2020/0345359 A1 11/2020 Baxter, III et al.
2020/0345360 A1 11/2020 Leimbach et al.
2020/0345435 A1 11/2020 Traina
2020/0345446 A1 11/2020 Kimball et al.
2020/0352562 A1 11/2020 Timm et al.
2020/0367885 A1 11/2020 Yates et al.
2020/0367886 A1 11/2020 Shelton, IV et al.
2020/0375585 A1 12/2020 Swayze et al.
2020/0375592 A1 12/2020 Hall et al.
2020/0375593 A1 12/2020 Hunter et al.
2020/0375597 A1 12/2020 Shelton, IV et al.
2020/0390444 A1 12/2020 Harris et al.
2020/0397433 A1 12/2020 Lytle, IV et al.
2020/0397434 A1 12/2020 Overmyer et al.
2020/0405290 A1 12/2020 Shelton, IV et al.
2020/0405291 A1* 12/2020 Shelton, IV A61B 50/30
2020/0405292 A1 12/2020 Shelton, IV et al.
2020/0405293 A1 12/2020 Shelton, IV et al.
2020/0405294 A1 12/2020 Shelton, IV
2020/0405295 A1 12/2020 Shelton, IV et al.
2020/0405296 A1 12/2020 Shelton, IV et al.
2020/0405297 A1 12/2020 Shelton, IV et al.
2020/0405301 A1 12/2020 Shelton, IV et al.
2020/0405302 A1 12/2020 Shelton, IV et al.
2020/0405303 A1 12/2020 Shelton, IV
2020/0405305 A1 12/2020 Shelton, IV et al.
2020/0405306 A1 12/2020 Shelton, IV et al.
2020/0405307 A1 12/2020 Shelton, IV et al.
2020/0405308 A1 12/2020 Shelton, IV
2020/0405309 A1 12/2020 Shelton, IV et al.
2020/0405311 A1 12/2020 Shelton, IV et al.
2020/0405312 A1 12/2020 Shelton, IV et al.
2020/0405313 A1 12/2020 Shelton, IV
2020/0405314 A1 12/2020 Shelton, IV et al.
2020/0405316 A1 12/2020 Shelton, IV et al.
2020/0405341 A1 12/2020 Hess et al.
2020/0405409 A1 12/2020 Shelton, IV et al.
2020/0405410 A1 12/2020 Shelton, IV
2020/0405416 A1 12/2020 Shelton, IV et al.
2020/0405422 A1 12/2020 Shelton, IV et al.
2020/0405436 A1 12/2020 Shelton, IV et al.
2020/0405437 A1 12/2020 Shelton, IV et al.
2020/0405438 A1 12/2020 Shelton, IV et al.
2020/0405439 A1 12/2020 Shelton, IV et al.
2020/0405440 A1 12/2020 Shelton, IV et al.
2020/0405441 A1 12/2020 Shelton, IV et al.
2020/0410177 A1 12/2020 Shelton, IV
2020/0410180 A1 12/2020 Shelton, IV et al.
2021/0000466 A1 1/2021 Leimbach et al.
2021/0000467 A1 1/2021 Shelton, IV et al.
2021/0000470 A1 1/2021 Leimbach et al.
2021/0015480 A1 1/2021 Shelton, IV et al.
2021/0022741 A1 1/2021 Baxter, III et al.
2021/0030416 A1 2/2021 Shelton, IV et al.
2021/0045742 A1 2/2021 Shelton, IV et al.
2021/0052271 A1 2/2021 Harris et al.
2021/0059661 A1 3/2021 Schmid et al.
2021/0059662 A1 3/2021 Shelton, IV
2021/0059664 A1 3/2021 Hensel et al.
2021/0059666 A1 3/2021 Schmid et al.
2021/0059669 A1 3/2021 Yates et al.
2021/0059670 A1 3/2021 Overmyer et al.
2021/0059671 A1 3/2021 Shelton, IV et al.
2021/0059672 A1 3/2021 Giordano et al.
2021/0059673 A1 3/2021 Shelton, IV et al.
2021/0068817 A1 3/2021 Shelton, IV et al.
2021/0068818 A1 3/2021 Overmyer et al.
2021/0068820 A1 3/2021 Parihar et al.
2021/0068829 A1 3/2021 Miller et al.
2021/0068830 A1 3/2021 Baber et al.
2021/0068831 A1 3/2021 Baber et al.
2021/0068832 A1 3/2021 Yates et al.
2021/0068835 A1 3/2021 Shelton, IV et al.
2021/0077092 A1 3/2021 Parihar et al.
2021/0077099 A1 3/2021 Shelton, IV et al.
2021/0077100 A1 3/2021 Shelton, IV et al.
2021/0077109 A1 3/2021 Harris et al.
2021/0085313 A1 3/2021 Morgan et al.
2021/0085314 A1 3/2021 Schmid et al.
2021/0085315 A1 3/2021 Aronhalt et al.
2021/0085316 A1 3/2021 Harris et al.
2021/0085317 A1 3/2021 Miller et al.
2021/0085318 A1 3/2021 Swayze et al.
2021/0085319 A1 3/2021 Swayze et al.

(56)

References Cited

U.S. PATENT DOCUMENTS

2021/0085320 A1 3/2021 Leimbach et al.
 2021/0085321 A1 3/2021 Shelton, IV et al.
 2021/0085325 A1 3/2021 Shelton, IV et al.
 2021/0085326 A1 3/2021 Vendely et al.
 2021/0093321 A1 4/2021 Auld et al.
 2021/0093323 A1 4/2021 Scirica et al.
 2021/0100541 A1 4/2021 Shelton, IV et al.
 2021/0100550 A1 4/2021 Shelton, IV et al.
 2021/0100982 A1 4/2021 Laby et al.
 2021/0106333 A1 4/2021 Shelton, IV et al.
 2021/0107031 A1 4/2021 Bales, Jr. et al.
 2021/0121175 A1 4/2021 Yates et al.
 2021/0128146 A1 5/2021 Shelton, IV et al.
 2021/0137522 A1 5/2021 Shelton, IV et al.
 2021/0186490 A1 6/2021 Shelton, IV et al.
 2021/0186492 A1 6/2021 Shelton, IV et al.
 2021/0186493 A1 6/2021 Shelton, IV et al.
 2021/0186494 A1 6/2021 Shelton, IV et al.
 2021/0186495 A1 6/2021 Shelton, IV et al.
 2021/0186497 A1 6/2021 Shelton, IV et al.
 2021/0186498 A1 6/2021 Boudreaux et al.
 2021/0186499 A1 6/2021 Shelton, IV et al.
 2021/0186500 A1 6/2021 Shelton, IV et al.
 2021/0186501 A1 6/2021 Shelton, IV et al.
 2021/0186502 A1 6/2021 Shelton, IV et al.
 2021/0186503 A1 6/2021 Shelton, IV et al.
 2021/0186504 A1 6/2021 Shelton, IV et al.
 2021/0186505 A1 6/2021 Shelton, IV et al.
 2021/0186506 A1 6/2021 Shelton, IV et al.
 2021/0186507 A1 6/2021 Shelton, IV et al.
 2021/0204941 A1 7/2021 Dewaele et al.
 2021/0212691 A1 7/2021 Smith et al.
 2021/0212776 A1 7/2021 Schmitt et al.
 2021/0219976 A1 7/2021 DiNardo et al.
 2021/0228209 A1 7/2021 Shelton, IV et al.
 2021/0236117 A1 8/2021 Morgan et al.
 2021/0236124 A1 8/2021 Shelton, IV et al.
 2021/0244406 A1 8/2021 Kerr et al.
 2021/0244407 A1 8/2021 Shelton, IV et al.
 2021/0244410 A1 8/2021 Swayze et al.
 2021/0244412 A1 8/2021 Vendely et al.
 2021/0259681 A1 8/2021 Shelton, IV et al.
 2021/0259687 A1 8/2021 Gonzalez et al.
 2021/0259986 A1 8/2021 Widenhouse et al.
 2021/0259987 A1 8/2021 Widenhouse et al.
 2021/0267589 A1 9/2021 Swayze et al.
 2021/0267592 A1 9/2021 Baxter, III et al.
 2021/0267594 A1 9/2021 Morgan et al.
 2021/0267595 A1 9/2021 Posada et al.
 2021/0267596 A1 9/2021 Fanelli et al.
 2021/0275053 A1 9/2021 Shelton, IV et al.
 2021/0275172 A1 9/2021 Harris et al.
 2021/0275173 A1 9/2021 Shelton, IV et al.
 2021/0275176 A1 9/2021 Beckman et al.
 2021/0282767 A1 9/2021 Shelton, IV et al.
 2021/0282769 A1 9/2021 Baxter, III et al.
 2021/0282774 A1 9/2021 Shelton, IV et al.
 2021/0282776 A1 9/2021 Overmyer et al.
 2021/0290226 A1 9/2021 Mandakolathur Vasudevan et al.
 2021/0290231 A1 9/2021 Baxter, III et al.
 2021/0290232 A1 9/2021 Harris et al.
 2021/0290233 A1 9/2021 Shelton, IV et al.
 2021/0290236 A1 9/2021 Moore et al.
 2021/0290322 A1 9/2021 Traina
 2021/0298745 A1 9/2021 Leimbach et al.
 2021/0298746 A1 9/2021 Leimbach et al.
 2021/0307748 A1 10/2021 Harris et al.
 2021/0307754 A1 10/2021 Shelton, IV et al.
 2021/0315566 A1 10/2021 Yates et al.
 2021/0315570 A1 10/2021 Shelton, IV
 2021/0315571 A1 10/2021 Swayze et al.
 2021/0315573 A1 10/2021 Shelton, IV et al.
 2021/0315574 A1 10/2021 Shelton, IV et al.
 2021/0315576 A1 10/2021 Shelton, IV et al.
 2021/0315577 A1 10/2021 Shelton, IV et al.

2021/0322009 A1 10/2021 Huang et al.
 2021/0330321 A1 10/2021 Leimbach et al.
 2021/0338233 A1 11/2021 Shelton, IV et al.
 2021/0338234 A1 11/2021 Shelton, IV et al.
 2021/0353284 A1 11/2021 Yang et al.
 2021/0369273 A1 12/2021 Yates et al.
 2021/0378669 A1 12/2021 Shelton, IV et al.
 2021/0393260 A1 12/2021 Shelton, IV et al.
 2021/0393261 A1 12/2021 Harris et al.
 2021/0393262 A1 12/2021 Shelton, IV et al.
 2021/0393268 A1 12/2021 Shelton, IV et al.
 2021/0393366 A1 12/2021 Shelton, IV et al.
 2022/0000478 A1 1/2022 Shelton, IV et al.
 2022/0031313 A1 2/2022 Bakos et al.
 2022/0031314 A1 2/2022 Bakos et al.
 2022/0031315 A1 2/2022 Bakos et al.
 2022/0031319 A1 2/2022 Witte et al.
 2022/0031320 A1 2/2022 Hall et al.
 2022/0031322 A1 2/2022 Parks
 2022/0031323 A1 2/2022 Witte
 2022/0031324 A1 2/2022 Hall et al.
 2022/0031345 A1 2/2022 Witte
 2022/0031346 A1 2/2022 Parks
 2022/0031350 A1 2/2022 Witte
 2022/0031351 A1 2/2022 Moubarak et al.
 2022/0054130 A1 2/2022 Overmyer et al.
 2022/0061836 A1 3/2022 Parihar et al.
 2022/0061843 A1 3/2022 Vendely et al.
 2022/0061845 A1 3/2022 Shelton, IV et al.
 2022/0061862 A1 3/2022 Shelton, IV et al.
 2022/0071630 A1 3/2022 Swayze et al.
 2022/0071631 A1 3/2022 Harris et al.
 2022/0071632 A1 3/2022 Patel et al.
 2022/0071635 A1 3/2022 Shelton, IV et al.
 2022/0079588 A1 3/2022 Harris et al.
 2022/0079589 A1 3/2022 Harris et al.
 2022/0079590 A1 3/2022 Harris et al.
 2022/0079595 A1 3/2022 Huitema et al.
 2022/0079596 A1 3/2022 Huitema et al.
 2022/0087676 A1 3/2022 Shelton, IV et al.

FOREIGN PATENT DOCUMENTS

AU 2012268848 A1 1/2013
 AU 2011218702 B2 6/2013
 AU 2012200178 B2 7/2013
 BR 112013007744 A2 6/2016
 BR 112013027777 A2 1/2017
 CA 1015829 A 8/1977
 CA 1125615 A 6/1982
 CA 2520413 A1 3/2007
 CA 2725181 A1 11/2007
 CA 2851239 A1 11/2007
 CA 2664874 A1 11/2009
 CA 2813230 A1 4/2012
 CA 2940510 A1 8/2015
 CA 2698728 C 8/2016
 CN 1163558 A 10/1997
 CN 2488482 Y 5/2002
 CN 1634601 A 7/2005
 CN 2716900 Y 8/2005
 CN 2738962 Y 11/2005
 CN 1777406 A 5/2006
 CN 2785249 Y 5/2006
 CN 2796654 Y 7/2006
 CN 2868212 Y 2/2007
 CN 200942099 Y 9/2007
 CN 200984209 Y 12/2007
 CN 200991269 Y 12/2007
 CN 201001747 Y 1/2008
 CN 101143105 A 3/2008
 CN 201029899 Y 3/2008
 CN 101188900 A 5/2008
 CN 101203085 A 6/2008
 CN 101273908 A 10/2008
 CN 101378791 A 3/2009
 CN 101507635 A 8/2009
 CN 101522120 A 9/2009
 CN 101669833 A 3/2010

(56)

References Cited

FOREIGN PATENT DOCUMENTS

CN	101716090	A	6/2010	DE	20016423	U1	2/2001
CN	101721236	A	6/2010	DE	20112837	U1	10/2001
CN	101756727	A	6/2010	DE	20121753	U1	4/2003
CN	101828940	A	9/2010	DE	202004012389	U1	9/2004
CN	101856250	A	10/2010	DE	10314072	A1	10/2004
CN	101873834	A	10/2010	DE	102004014011	A1	10/2005
CN	201719298	U	1/2011	DE	102004041871	A1	3/2006
CN	102038532	A	5/2011	DE	102004063606	A1	7/2006
CN	201879759	U	6/2011	DE	202007003114	U1	6/2007
CN	201949071	U	8/2011	DE	102010013150	A1	9/2011
CN	102217961	A	10/2011	DE	102012213322	A1	1/2014
CN	102217963	A	10/2011	DE	102013101158	A1	8/2014
CN	102243850	A	11/2011	EM	1558161	A1	8/2005
CN	102247182	A	11/2011	EM	002220467-0008		4/2013
CN	102247183	A	11/2011	EP	0000756	A1	2/1979
CN	101779977	B	12/2011	EP	0122046	A1	10/1984
CN	102309352	A	1/2012	EP	0129442	B1	11/1987
CN	101912284	B	7/2012	EP	0251444	A1	1/1988
CN	102125450	B	7/2012	EP	0255631	A1	2/1988
CN	202313537	U	7/2012	EP	0169044	B1	6/1991
CN	202397539	U	8/2012	EP	0541950	A1	5/1993
CN	202426586	U	9/2012	EP	0548998	A1	6/1993
CN	102743201	A	10/2012	EP	0594148	A1	4/1994
CN	202489990	U	10/2012	EP	0646357	A1	4/1995
CN	102228387	B	11/2012	EP	0505036	B1	5/1995
CN	102835977	A	12/2012	EP	0669104	A1	8/1995
CN	202568350	U	12/2012	EP	0705571	A1	4/1996
CN	103037781	A	4/2013	EP	0528478	B1	5/1996
CN	103083053	A	5/2013	EP	0770355	A1	5/1997
CN	103391037	A	11/2013	EP	0625335	B1	11/1997
CN	203328751	U	12/2013	EP	0879742	A1	11/1998
CN	103505264	A	1/2014	EP	0650701	B1	3/1999
CN	103584893	A	2/2014	EP	0923907	A1	6/1999
CN	103635150	A	3/2014	EP	0484677	B2	7/2000
CN	103690212	A	4/2014	EP	1034747	A1	9/2000
CN	203564285	U	4/2014	EP	1034748	A1	9/2000
CN	203564287	U	4/2014	EP	0726632	B1	10/2000
CN	203597997	U	5/2014	EP	1053719	A1	11/2000
CN	103829981	A	6/2014	EP	1055399	A1	11/2000
CN	103829983	A	6/2014	EP	1055400	A1	11/2000
CN	103860221	A	6/2014	EP	1064882	A1	1/2001
CN	103908313	A	7/2014	EP	1080694	A1	3/2001
CN	203693685	U	7/2014	EP	1090592	A1	4/2001
CN	203736251	U	7/2014	EP	1095627	A1	5/2001
CN	103981635	A	8/2014	EP	0806914	B1	9/2001
CN	104027145	A	9/2014	EP	1234587	A1	8/2002
CN	203815517	U	9/2014	EP	1284120	A1	2/2003
CN	102783741	B	10/2014	EP	0717967	B1	5/2003
CN	102973300	B	10/2014	EP	0869742	B1	5/2003
CN	204092074	U	1/2015	EP	1374788	A1	1/2004
CN	104337556	A	2/2015	EP	1407719	A2	4/2004
CN	204158440	U	2/2015	EP	0996378	B1	6/2004
CN	204158441	U	2/2015	EP	1157666	B1	9/2005
CN	102469995	B	3/2015	EP	0880338	B1	10/2005
CN	104422849	A	3/2015	EP	1158917	B1	11/2005
CN	104586463	A	5/2015	EP	1344498	B1	11/2005
CN	204520822	U	8/2015	EP	1330989	B1	12/2005
CN	204636451	U	9/2015	EP	1632191	A2	3/2006
CN	103860225	B	3/2016	EP	1082944	B1	5/2006
CN	103750872	B	5/2016	EP	1253866	B1	7/2006
CN	105919642	A	9/2016	EP	1723914	A1	11/2006
CN	103648410	B	10/2016	EP	1285633	B1	12/2006
CN	105997173	A	10/2016	EP	1011494	B1	1/2007
CN	106344091	A	1/2017	EP	1767163	A1	3/2007
CN	104349800	B	11/2017	EP	1837041	A1	9/2007
CN	107635483	A	1/2018	EP	0922435	B1	10/2007
CN	208625784	U	3/2019	EP	1599146	B1	10/2007
DE	273689	C	5/1914	EP	1330201	B1	6/2008
DE	1775926	A	1/1972	EP	2039302	A2	3/2009
DE	3036217	A1	4/1982	EP	1719461	B1	6/2009
DE	3210466	A1	9/1983	EP	2116196	A2	11/2009
DE	3709067	A1	9/1988	EP	1769754	B1	6/2010
DE	19534043	A1	3/1997	EP	1627605	B1	12/2010
DE	19851291	A1	1/2000	EP	2316345	A1	5/2011
DE	19924311	A1	11/2000	EP	1962711	B1	2/2012
				EP	2486862	A2	8/2012
				EP	2486868	A2	8/2012
				EP	2517638	A1	10/2012
				EP	2606812	A1	6/2013

(56)

References Cited

FOREIGN PATENT DOCUMENTS				JP			
EP	2649948	A1	10/2013	JP	H08164141	A	6/1996
EP	2649949	A1	10/2013	JP	H08182684	A	7/1996
EP	2668910	A2	12/2013	JP	H08507708	A	8/1996
EP	2687164	A2	1/2014	JP	H08229050	A	9/1996
EP	2713902	A1	4/2014	JP	H08289895	A	11/1996
EP	2743042	A2	6/2014	JP	H09-323068	A	12/1997
EP	2764827	A2	8/2014	JP	H10118090	A	5/1998
EP	2777524	A2	9/2014	JP	H10-200699	A	7/1998
EP	2789299	A1	10/2014	JP	H10296660	A	11/1998
EP	2842500	A1	3/2015	JP	2000014632	A	1/2000
EP	2853220	A1	4/2015	JP	2000033071	A	2/2000
EP	2878274	A1	6/2015	JP	2000112002	A	4/2000
EP	2298220	B1	6/2016	JP	2000166932	A	6/2000
EP	2510891	B1	6/2016	JP	2000171730	A	6/2000
EP	3031404	A1	6/2016	JP	2000210299	A	8/2000
EP	3047806	A1	7/2016	JP	2000271141	A	10/2000
EP	3078334	A1	10/2016	JP	2000287987	A	10/2000
EP	2364651	B1	11/2016	JP	2000325303	A	11/2000
EP	2747235	B1	11/2016	JP	2001-69758	A	3/2001
EP	3095399	A2	11/2016	JP	2001087272	A	4/2001
EP	3120781	A2	1/2017	JP	2001208655	A	8/2001
EP	3135225	A2	3/2017	JP	2001514541	A	9/2001
EP	2789299	B1	5/2017	JP	2001276091	A	10/2001
EP	3225190	A2	10/2017	JP	2002051974	A	2/2002
EP	3326548	A1	5/2018	JP	2002054903	A	2/2002
EP	3363378	A1	8/2018	JP	2002085415	A	3/2002
EP	3409216	A1	12/2018	JP	2002143078	A	5/2002
EP	3476334	A1	5/2019	JP	2002153481	A	5/2002
EP	3275378	B1	7/2019	JP	2002528161	A	9/2002
ES	1070456	U	9/2009	JP	2002314298	A	10/2002
FR	459743	A	11/1913	JP	2003135473	A	5/2003
FR	999646	A	2/1952	JP	2003521301	A	7/2003
FR	1112936	A	3/1956	JP	3442423	B2	9/2003
FR	2598905	A1	11/1987	JP	2003300416	A	10/2003
FR	2689749	B1	7/1994	JP	2004147701	A	5/2004
FR	2765794	A1	1/1999	JP	2004162035	A	6/2004
FR	2815842	A1	5/2002	JP	2004229976	A	8/2004
GB	939929	A	10/1963	JP	2005013573	A	1/2005
GB	1210522	A	10/1970	JP	2005080702	A	3/2005
GB	1217159	A	12/1970	JP	2005131163	A	5/2005
GB	1339394	A	12/1973	JP	2005131164	A	5/2005
GB	2024012	A	1/1980	JP	2005131173	A	5/2005
GB	2109241	A	6/1983	JP	2005131211	A	5/2005
GB	2090534	B	6/1984	JP	2005131212	A	5/2005
GB	2272159	A	5/1994	JP	2005137423	A	6/2005
GB	2336214	A	10/1999	JP	2005187954	A	7/2005
GB	2509523	A	7/2014	JP	2005211455	A	8/2005
GR	930100110	A	11/1993	JP	2005328882	A	12/2005
JP	S4711908	Y1	5/1972	JP	2005335432	A	12/2005
JP	S5033988	U	4/1975	JP	2005342267	A	12/2005
JP	S5367286	A	6/1978	JP	3791856	B2	6/2006
JP	S56112235	A	9/1981	JP	2006187649	A	7/2006
JP	S60113007	A	6/1985	JP	2006218228	A	8/2006
JP	S62170011	U	10/1987	JP	2006281405	A	10/2006
JP	S63270040	A	11/1988	JP	2006291180	A	10/2006
JP	S63318824	A	12/1988	JP	2006346445	A	12/2006
JP	H0129503	B2	6/1989	JP	2007-97252	A	4/2007
JP	H02106189	A	4/1990	JP	2007289715	A	11/2007
JP	H0378514	U	8/1991	JP	2007304057	A	11/2007
JP	H0385009	U	8/1991	JP	2007306710	A	11/2007
JP	H04215747	A	8/1992	JP	D1322057		2/2008
JP	H04131860	U	12/1992	JP	2008154804	A	7/2008
JP	H0584252	A	4/1993	JP	2008220032	A	9/2008
JP	H05123325	A	5/1993	JP	2009507526	A	2/2009
JP	H05226945	A	9/1993	JP	2009189838	A	8/2009
JP	H0630945	A	2/1994	JP	2009189846	A	8/2009
JP	H06237937	A	8/1994	JP	2009207260	A	9/2009
JP	H06304176	A	11/1994	JP	2009226028	A	10/2009
JP	H06327684	A	11/1994	JP	2009538684	A	11/2009
JP	H079622	U	2/1995	JP	2009539420	A	11/2009
JP	H07124166	A	5/1995	JP	D1383743		2/2010
JP	H07163573	A	6/1995	JP	2010065594	A	3/2010
JP	H07255735	A	10/1995	JP	2010069307	A	4/2010
JP	H07285089	A	10/1995	JP	2010069310	A	4/2010
JP	H0833642	A	2/1996	JP	2010098844	A	4/2010
				JP	2010214128	A	9/2010
				JP	2011072574	A	4/2011
				JP	4722849	B2	7/2011
				JP	4728996	B2	7/2011

(56)

References Cited

FOREIGN PATENT DOCUMENTS

WO WO-2016100682 A1 6/2016
WO WO-2016107448 A1 7/2016
WO WO-2019036490 A1 2/2019

OTHER PUBLICATIONS

- JAMA Network, "Postendoscopic Zenker Esophagodiverticulostomy Leaks Associated With a Specific Stapler Cartridge", first available Feb. 2002. (<https://jamanetwork.com/journals/jamaotolaryngology/fullarticle/482754?resultClick=1>) (Year: 2002).*
- Wiley Online Library, "A simple and safe pancreas transection using a stapling device for a distal pancreatectomy", first available Aug. 1, 2008. (<https://onlinelibrary.wiley.com/doi/full/10.1007/s00534-008-1328-8>) (Year: 2008).*
- Youtube, "ECHELON FLEX Powered Vascular Stapler In-Service | Ethicon", first available Mar. 13, 2020. (https://www.youtube.com/watch?v=lw6U_pcv_gl) (Year: 2020).*
- ASTM procedure D2240-00, "Standard Test Method for Rubber Property-Durometer Hardness," (Published Aug. 2000).
- ASTM procedure D2240-05, "Standard Test Method for Rubber Property-Durometer Hardness," (Published Apr. 2010).
- Van Meer et al., "A Disposable Plastic Compact Wrist for Smart Minimally Invasive Surgical Tools," LAAS/CNRS (Aug. 2005).
- Breedveld et al., "A New, Easily Miniaturized Sterrable Endoscope," *IEEE Engineering in Medicine and Biology Magazine* (Nov./Dec. 2005).
- Disclosed Anonymously, "Motor-Driven Surgical Stapler Improvements," Research Disclosure Database No. 526041, Published: Feb. 2008.
- B.R. Coolman, DVM, MS et al., "Comparison of Skin Staples With Sutures for Anastomosis of the Small Intestine in Dogs," Abstract; <http://www.blackwell-synergy.com/doi/abs/10.1053/jvet.2000.7539?cookieSet=1&journalCode=vsu> which redirects to <http://www3.interscience.wiley.com/journal/119040681/abstract?CRETRY=1&SRETRY=0>; [online] accessed: Sep. 22, 2008 (2 pages).
- D. Tuite, Ed., "Get The Lowdown On Ultracapacitors," Nov. 15, 2007; [online] URL: <http://electronicdesign.com/Articles/Print.cfm?ArticleID=17465>, accessed Jan. 15, 2008 (5 pages).
- Datasheet for Panasonic TK Relays Ultra Low Profile 2 A Polarized Relay, Copyright Matsushita Electric Works, Ltd. (Known of at least as early as Aug. 17, 2010), 5 pages.
- Schellhammer et al., "Poly-Lactic-Acid for Coating of Endovascular Stents: Preliminary Results in Canine Experimental Av-Fistulae," *Mat.-wiss. u. Werkstofftech.*, 32, pp. 193-199 (2001).
- Miyata et al., "Biomolecule-Sensitive Hydrogels," *Advanced Drug Delivery Reviews*, 54 (2002) pp. 79-98.
- Jeong et al., "Thermosensitive Sol-Gel Reversible Hydrogels," *Advanced Drug Delivery Reviews*, 54 (2002) pp. 37-51.
- Covidien Brochure, "Endo GIA™ Ultra Universal Stapler," (2010), 2 pages.
- Qiu et al., "Environment-Sensitive Hydrogels for Drug Delivery," *Advanced Drug Delivery Reviews*, 53 (2001) pp. 321-339.
- Hoffman, "Hydrogels for Biomedical Applications," *Advanced Drug Delivery Reviews*, 43 (2002) pp. 3-12.
- Hoffman, "Hydrogels for Biomedical Applications," *Advanced Drug Delivery Reviews*, 54 (2002) pp. 3-12.
- Peppas, "Physiologically Responsive Hydrogels," *Journal of Bioactive and Compatible Polymers*, vol. 6 (Jul. 1991) pp. 241-246.
- Peppas, Editor "Hydrogels in Medicine and Pharmacy," vol. I, *Fundamentals*, CRC Press, 1986.
- Young, "Microcellular foams via phase separation," *Journal of Vacuum Science & Technology A* 4(3), (May/June. 1986).
- Ebara, "Carbohydrate-Derived Hydrogels and Microgels," *Engineered Carbohydrate-Based Materials for Biomedical Applications: Polymers, Surfaces, Dendrimers, Nanoparticles, and Hydrogels*, Edited by Ravin Narain, 2011, pp. 337-345.
- <http://ninpgan.net/publications/51-100/89.pdf>; 2004, Ning Pan, On Uniqueness of Fibrous Materials, Design & Nature II. Eds: Colins, M. and Brebbia, C. WIT Press, Boston, 493-504.
- Solorio et al., "Gelatin Microspheres Crosslinked with Genipin for Local Delivery of Growth Factors," *J. Tissue Eng. Regen. Med.* (2010), 4(7): pp. 514-523.
- Covidien iDrive™ Ultra in Service Reference Card, "iDrive™ Ultra Powered Stapling Device," (4 pages).
- Covidien iDrive™ Ultra Powered Stapling System brochure, "The Power of iDrive™ Ultra Powered Stapling System and Tri-Staple™ Technology," (23 pages).
- Covidien "iDrive™ Ultra Powered Stapling System, A Guide for Surgeons," (6 pages).
- Covidien "iDrive™ Ultra Powered Stapling System, Cleaning and Sterilization Guide," (2 pages).
- Covidien Brochure "iDrive™ Ultra Powered Stapling System," (6 pages).
- Covidien Brochure, "Endo GIA™ Reloads with Tri-Staple™ Technology," (2010), 1 page.
- Covidien Brochure, "Endo GIA™ Reloads with Tri-Staple™ Technology and Endo GIA™ Ultra Universal Staplers," (2010), 2 pages.
- Covidien Brochure, "Endo GIA™ Curved Tip Reload with Tri-Staple™ Technology," (2012), 2 pages.
- Covidien Brochure, "Endo GIA™ Reloads with Tri-Staple™ Technology," (2010), 2 pages.
- Pitt et al., "Attachment of Hyaluronan to Metallic Surfaces," *J. Biomed. Mater. Res.* 68A: pp. 95-106, 2004.
- Indian Standard: Automotive Vehicles—Brakes and Braking Systems (IS 11852-1:2001), Mar. 1, 2001.
- Patrick J. Sweeney: "RFID for Dummies", Mar. 11, 2010, pp. 365-365, XP055150775, ISBN: 978-1-11-805447-5, Retrieved from the Internet: URL: books.google.de/books?isbn=1118054474 [retrieved on Nov. 4, 2014]—book not attached.
- Allegro MicroSystems, LLC, Automotive Full Bridge MOSFET Driver, A3941-DS, Rev. 5, 21 pages, <http://www.allegromicro.com/~media/Files/Datasheets/A3941-Datasheet.ashx?la=en>.
- Data Sheet of LM4F230H5QR, 2007.
- Seils et al., Covidien Summary: Clinical Study "UCONN Biodynamics: Final Report on Results," (2 pages).
- Byrne et al., "Molecular Imprinting Within Hydrogels," *Advanced Drug Delivery Reviews*, 54 (2002) pp. 149-161.
- Fast, Versatile Blackfin Processors Handle Advanced RFID Reader Applications; *Analog Dialogue*: vol. 40—Sep. 2006; <http://www.analog.com/library/analogDialogue/archives/40-09/rfid.pdf>; Wayback Machine to Feb. 15, 2012.
- Chen et al., "Elastomeric Biomaterials for Tissue Engineering," *Progress in Polymer Science* 38 (2013), pp. 584-671.
- Matsuda, "Thermodynamics of Formation of Porous Polymeric Membrane from Solutions," *Polymer Journal*, vol. 23, No. 5, pp. 435-444 (1991).
- Covidien Brochure, "Endo GIA™ Black Reload with Tri-Staple™ Technology," (2012), 2 pages.
- Biomedical Coatings, Fort Wayne Metals, Research Products Corporation, obtained online at www.fwmetals.com on Jun. 21, 2010 (1 page).
- The Sodem Aseptic Battery Transfer Kit, Sodem Systems, 2000, 3 pages.
- C.C. Thompson et al., "Peroral Endoscopic Reduction of Dilated Gastrojejunum Anastomosis After Roux-en-Y Gastric Bypass: A Possible New Option for Patients with Weight Regain," *Surg Endosc* (2006) vol. 20., pp. 1744-1748.
- Serial Communication Protocol; Michael Lemmon Feb. 1, 2009; <http://www3.nd.edu/~lemmon/courses/ee224/web-manual/web-manual/lab12/node2.html>; Wayback Machine to Apr. 29, 2012.
- Lyon et al. "The Relationship Between Current Load and Temperature for Quasi-Steady State and Transient Conditions," *SPIE—International Society for Optical Engineering. Proceedings*, vol. 4020, (pp. 62-70), Mar. 30, 2000.
- Anonymous: "Sense & Control Application Note Current Sensing Using Linear Hall Sensors," Feb. 3, 2009, pp. 1-18. Retrieved from the Internet: URL: http://www.infineon.com/dgdl/Current_Sensing_Rev.1.1.pdf?fileId=db3a304332d040720132d939503e5f17 [retrieved on Oct. 18, 2016].

(56)

References Cited

OTHER PUBLICATIONS

Mouser Electronics, "LM317M 3-Terminal Adjustable Regulator with Overcurrent/Overtemperature Self Protection", Mar. 31, 2014 (Mar. 31, 2014), XP0555246104, Retrieved from the Internet: URL: <http://www.mouser.com/ds/2/405/lm317m-440423.pdf>, pp. 1-8.

Mouser Electronics, "LM317 3-Terminal Adjustable Regulator with Overcurrent/Overtemperature Self Protection", Sep. 30, 2016 (Sep. 30, 2016), XP0555246104, Retrieved from the Internet: URL: <http://www.mouser.com/ds/2/405/lm317m-440423.pdf>, pp. 1-9.

Cuper et al., "The Use of Near-Infrared Light for Safe and Effective Visualization of Subsurface Blood Vessels to Facilitate Blood Withdrawal in Children," *Medical Engineering & Physics*, vol. 35, No. 4, pp. 433-440 (2013).

Yan et al., Comparison of the effects of Mg—6Zn and Ti—3Al—2.5V alloys on TGF- β /TNF- α /VEGF/b-FGF in the healing of the intestinal track in vivo, *Biomed. Mater.* 9 (2014), 11 pages.

Pellicer et al. "On the biodegradability, mechanical behavior, and cytocompatibility of amorphous Mg72Zn23Ca5 and crystalline Mg70Zn23Ca5Pd2 alloys as temporary implant materials," *J Biomed Mater Res Part A*, 2013:101A:502-517.

Anonymous, Analog Devices Wiki, Chapter 11: The Current Mirror, Aug. 20, 2017, 22 pages. <https://wiki.analog.com/university/courses/electronics/text/chapter-11?rev=1503222341>.

Yan et al., "Comparison of the effects of Mg—6Zn and titanium on intestinal tract in vivo," *J Mater Sci: Mater Med* (2013), 11 pages.

Brar et al., "Investigation of the mechanical and degradation properties of Mg—Sr and Mg—Zn—Sr alloys for use as potential biodegradable implant materials," *J. Mech. Behavior of Biomed. Mater.* 7 (2012) pp. 87-95.

Texas Instruments: "Current Recirculation and Decay Modes," Application Report SLVA321—Mar. 2009; Retrieved from the Internet: URL:<http://www.ti.com/lit/an/slva321/slva321> [retrieved on Apr. 25, 2017], 7 pages.

Qiu Li Loh et al.: "Three-Dimensional Scaffolds for Tissue Engineering Applications: Role of Porosity and Pore Size", *Tissue Engineering Part B—Reviews*, vol. 19, No. 6, Dec. 1, 2013, pp. 485-502.

Gao et al., "Mechanical Signature Enhancement of Response Vibrations in the Time Lag Domain," Fifth International Congress on Sound and Vibration, Dec. 15-18, 1997, pp. 1-8.

Trendafilova et al., "Vibration-based Methods for Structural and Machinery Fault Diagnosis Based on Nonlinear Dynamics Tools," In: *Fault Diagnosis in Robotic and Industrial Systems*, IConcept Press LTD, 2012, pp. 1-29.

Youtube.com; video by Fibran (retrieved from URL <https://www.youtube.com/watch?v=vN2Qjt51gFQ>); (Year: 2018).

Foot and Ankle: Core Knowledge in Orthopaedics; by DiGiovanni MD, Elsevier; (p. 27, left column, heading "Materials for Soft Orthoses", 7th bullet point); (Year: 2007).

Lee, Youbok, "Antenna Circuit Design for RFID Applications," 2003, pp. 1-50, DS00710C, Microchip Technology Inc., Available: <http://ww1.microchip.com/downloads/en/AppNotes/00710c.pdf>.

Kawamura, Atsuo, et al. "Wireless Transmission of Power and Information Through One High-Frequency Resonant AC Link Inverter for Robot Manipulator Applications," *Journal*, May/June. 1996, pp. 503-508, vol. 32, No. 3, *IEEE Transactions on Industry Applications*.

Honda HS1332AT and ATD Model Info, powerequipment.honda.com [online], published on or before Mar. 22, 2016, [retrieved on May 31, 2019], retrieved from the Internet [URL: <https://powerequipment.honda.com/snowblowers/models/hss1332at-hss1332atd>] {Year: 2016}.

Slow Safety Sign, shutterstock.com [online], published on or before May 9, 2017, [retrieved on May 31, 2019], retrieved from the <https://www.shutterstock.com/image-vector/slow-safety-sign-twodimensional-turtle-symbolizing-> . . . see PDF in file for full URL.] (Year: 2017).

Warning Sign Beveled Buttons, by Peter, flarestock.com [online], published on or before Jan. 1, 2017, [retrieved on Jun. 4, 2019],

retrieved from the Internet [URL: <https://www.flarestock.com/stock-images/warning-sign-beveled-buttons/70257>] (Year: 2017).

Arrow Sign Icon Next Button, by Blan-k, shutterstock.com [online], published on or before Aug. 6, 2014, [retrieved on Jun. 4, 2019], retrieved from the Internet [URL:<https://www.shutterstock.com/de/image-vector/arrow-sign-icon-next-button-navigation-207700303?irgwc=1&utm> . . . see PDF in file for full URL.] (Year: 2014).

Elite Icons, by smart/icons, iconfinder.com [online], published on Aug. 18, 2016, [retrieved on Jun. 4, 2019], retrieved from the Internet [URL: <https://www.iconfinder.com/iconsets/elite>] (Year: 2016).

Tutorial overview of inductively coupled RFID Systems, UPM, May 2003, pp. 1-7, UPM Rafsec, <<http://cdn.mobiusconsulting.com/papers/rfidsystems.pdf>>.

Schroeter, John, "Demystifying UHF Gen 2 RFID, HF RFID," Online Article, Jun. 2, 2008, pp. 1-3, <<https://www.edn.com/design/industrial-control/4019123/Demystifying-UHF-Gen-2-RFID-HF-RFID>>.

Adeeb, et al., "An Inductive Link-Based Wireless Power Transfer System for Biomedical Applications," Research Article, Nov. 14, 2011, pp. 1-12, vol. 2012, Article ID 879294, Hindawi Publishing Corporation.

Pushing Pixels (GIF), published on dribbble.com, 2013.

Sodium stearate C18H35NaO2, Chemspider Search and Share Chemistry, Royal Society of Chemistry, pp. 1-3, 2015, <http://www.chemspider.com/Chemical-Structure.12639.html>, accessed May 23, 2016.

NF Monographs: Sodium Stearate, U.S. Pharmacopeia, http://www.pharmacopeia.cn/v29240/usp29nf24s0_m77360.html, accessed May 23, 2016.

Fischer, Martin H, "Colloid-Chemical Studies on Soaps", *The Chemical Engineer*, pp. 184-193, Aug. 1919.

V.K. Ahluwalia and Madhuri Goyal, *A Textbook of Organic Chemistry*, Section 19.11.3, p. 356, 2000.

A.V. Kasture and S.G. Wadodkar, *Pharmaceutical Chemistry—II: Second Year Diploma in Pharmacy*, Nirali Prakashan, p. 339, 2007.

Forum discussion regarding "Speed is Faster", published on Oct. 1, 2014 and retrieved on Nov. 8, 2019 from URL <https://english.stackexchange.com/questions/199018/how-is-that-correct-speed-is-faster-or-prices-are-cheaper> (Year: 2014).

"Understanding the Requirements of ISO/IEC 14443 for Type B Proximity Contactless Identification Cards," retrieved from <https://www.digchip.com/application-notes/22/15746.php> on Mar. 2, 2020, pp. 1-28 (Nov. 2005).

Jauchem, J.R., "Effects of low-level radio-frequency (3 kHz to 300 GHz) energy on human cardiovascular, reproductive, immune, and other systems: A review of the recent literature," *Int. J. Hyg. Environ. Health* 211 (2008) 1-29.

Sandvik, "Welding Handbook," <https://www.meting.rs/wp-content/uploads/2018/05/welding-handbook.pdf>, retrieved on Jun. 22, 2020, pp. 5-6.

Ludois, Daniel C., "Capacitive Power Transfer for Rotor Field Current in Synchronous Machines," *IEEE Transactions on Power Electronics*, Institute of Electrical and Electronics Engineers, USA, vol. 27, No. 11, Nov. 1, 2012, pp. 4638-4645.

Rotary Systems: Sealed Slip Ring Categories, Rotary Systems, May 22, 2017, retrieved from the internet: <http://web.archive.org/web/20170522174710/http://rotarysystems.com:80/slip-rings/sealed/>, retrieved on Aug. 12, 2020, pp. 1-2.

IEEE Std 802.3-2012 (Revision of IEEE Std 802.3-2008, published Dec. 28, 2012).

"ATM-MPLS Network Interworking Version 2.0, af-aic-0178.001" ATM Standard, The ATM Forum Technical Committee, published Aug. 2003.

Yang et al., "4D printing reconfigurable, deployable and mechanically tunable metamaterials," *Material Horizons*, vol. 6, pp. 1244-1250 (2019).

"Council Directive 93/42/EEC of Jun. 14, 1993 Concerning Medical Devices," Official Journal of the European Communities, L&C. Legislation and Competition, S, No. L 169, Jun. 14, 1993, pp. 1-43.

* cited by examiner

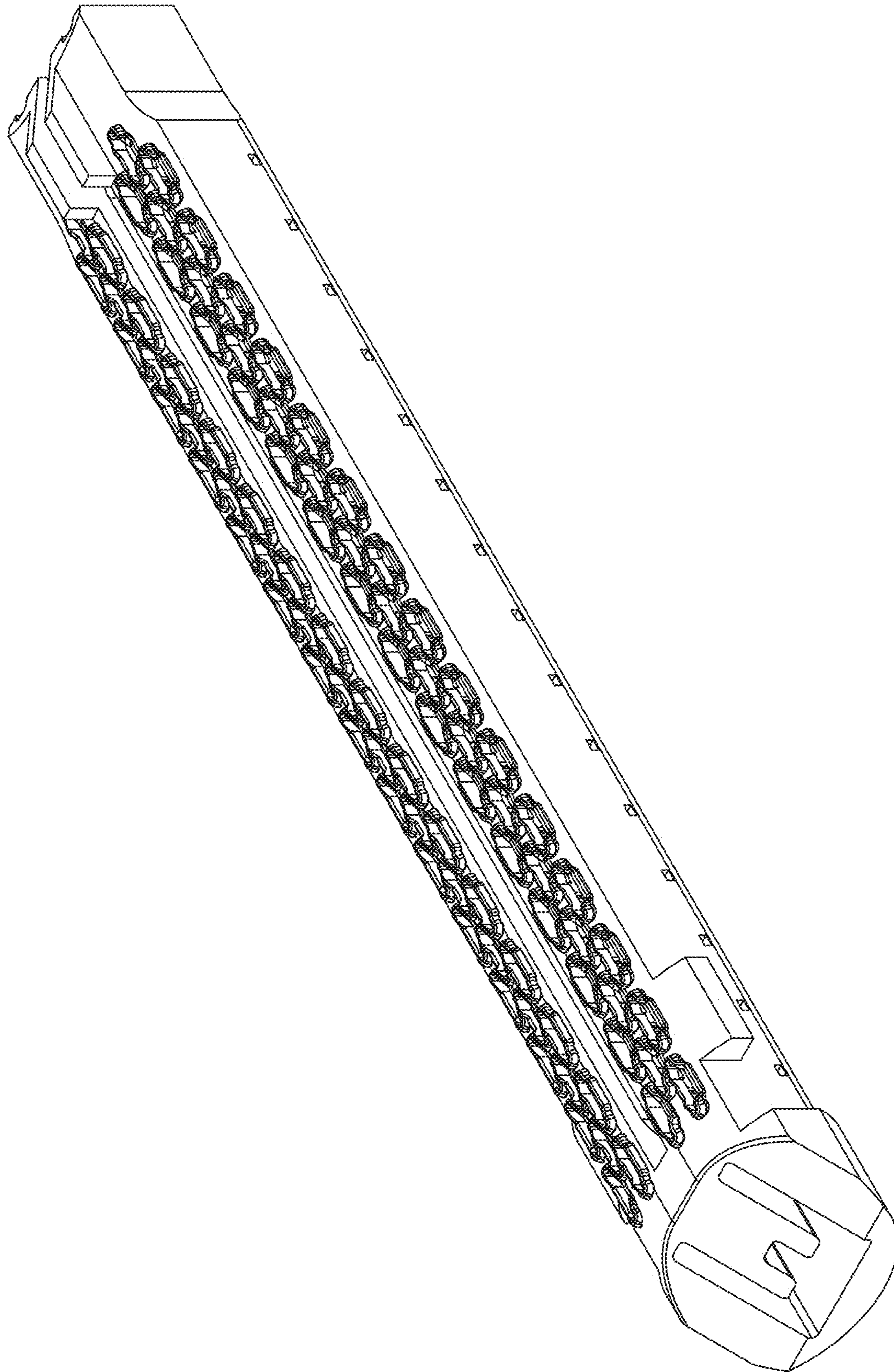

FIG. 1

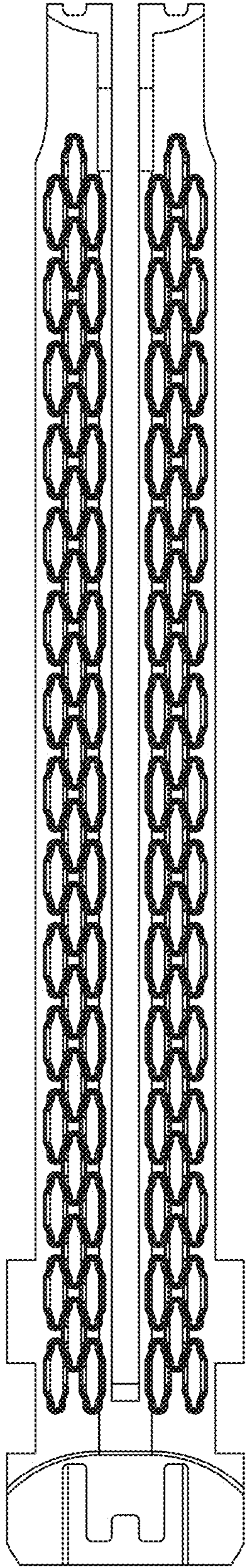

FIG. 2

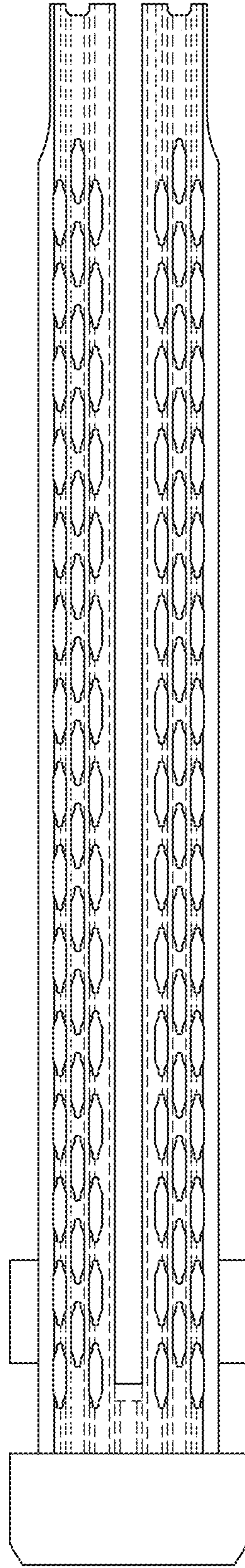

FIG. 3

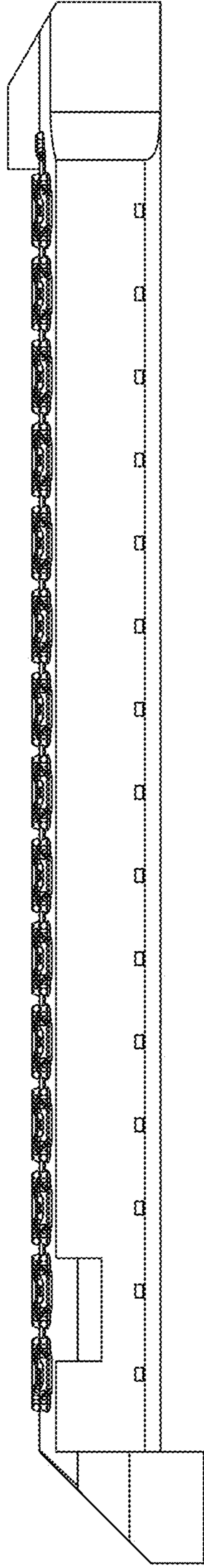

FIG. 4

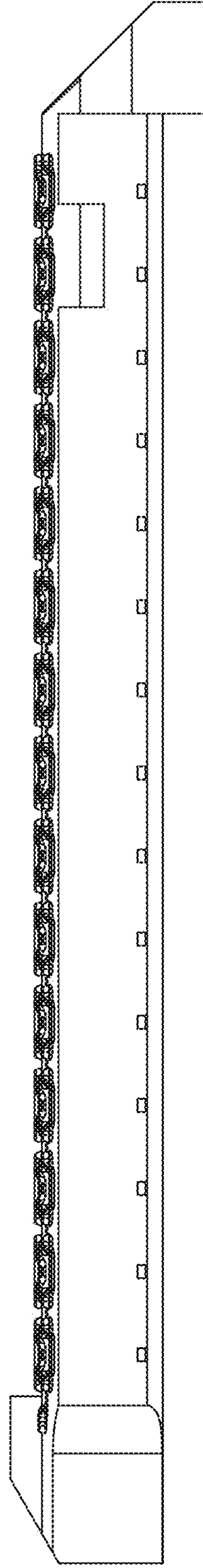

FIG. 5

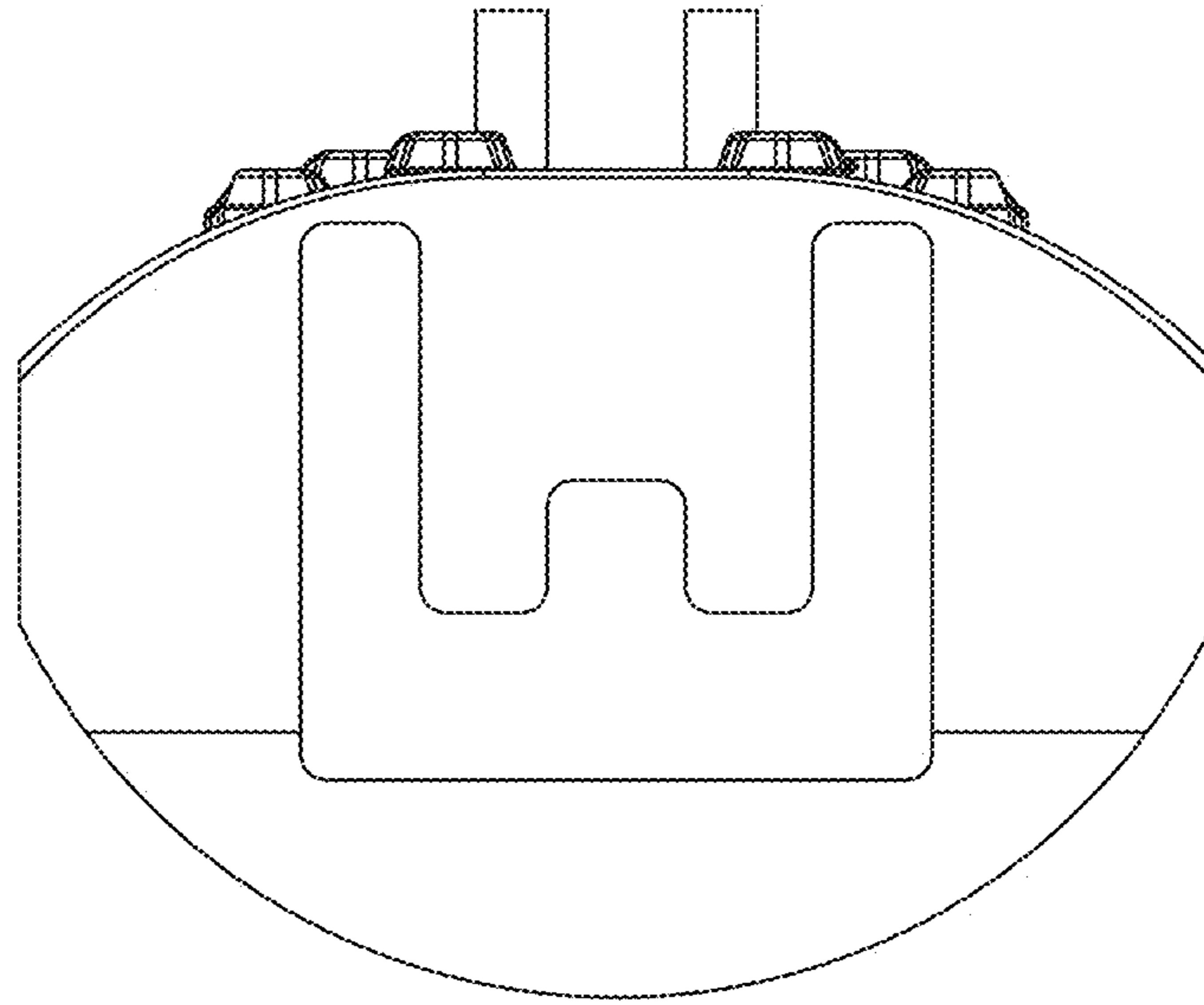

FIG. 6

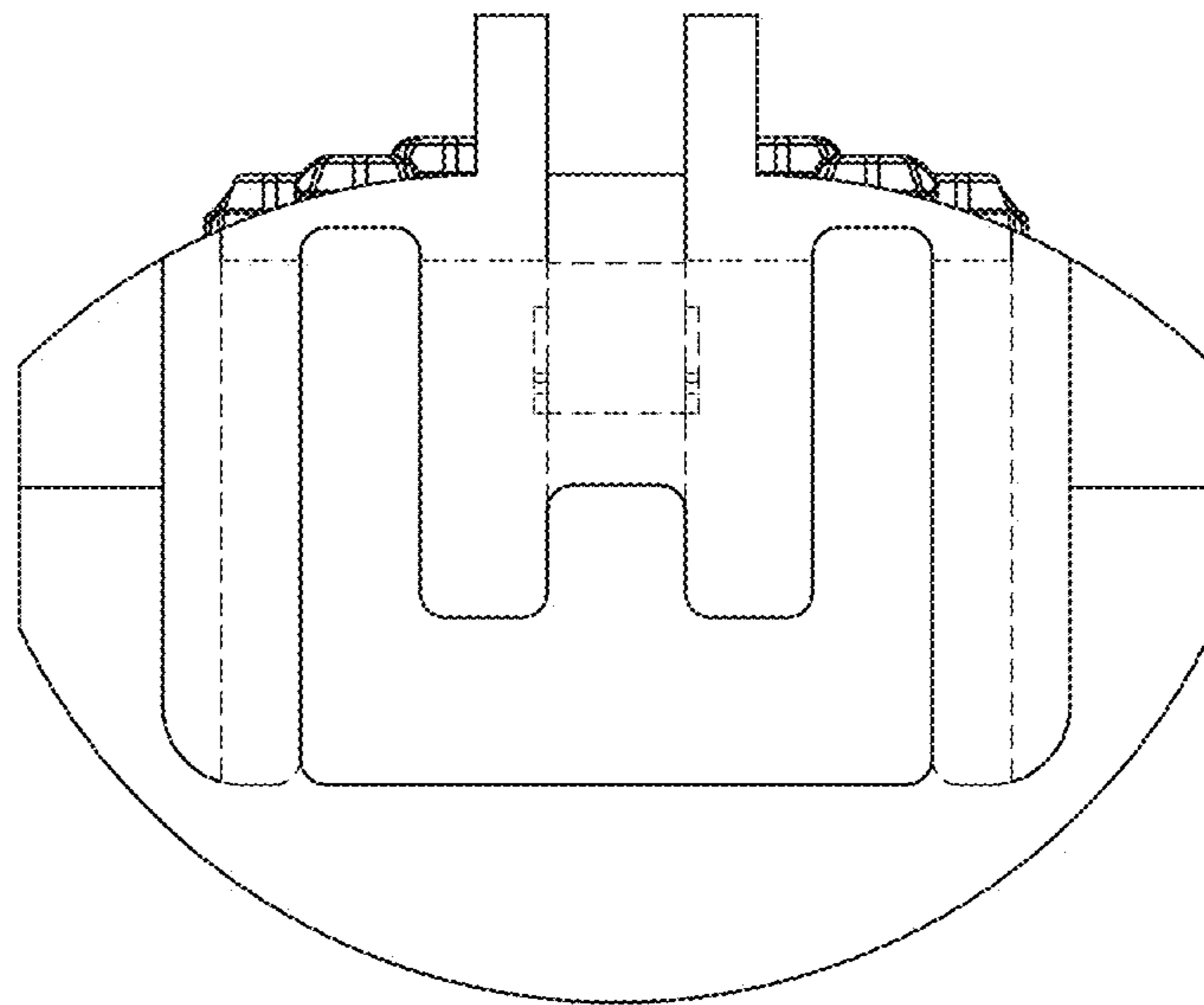

FIG. 7

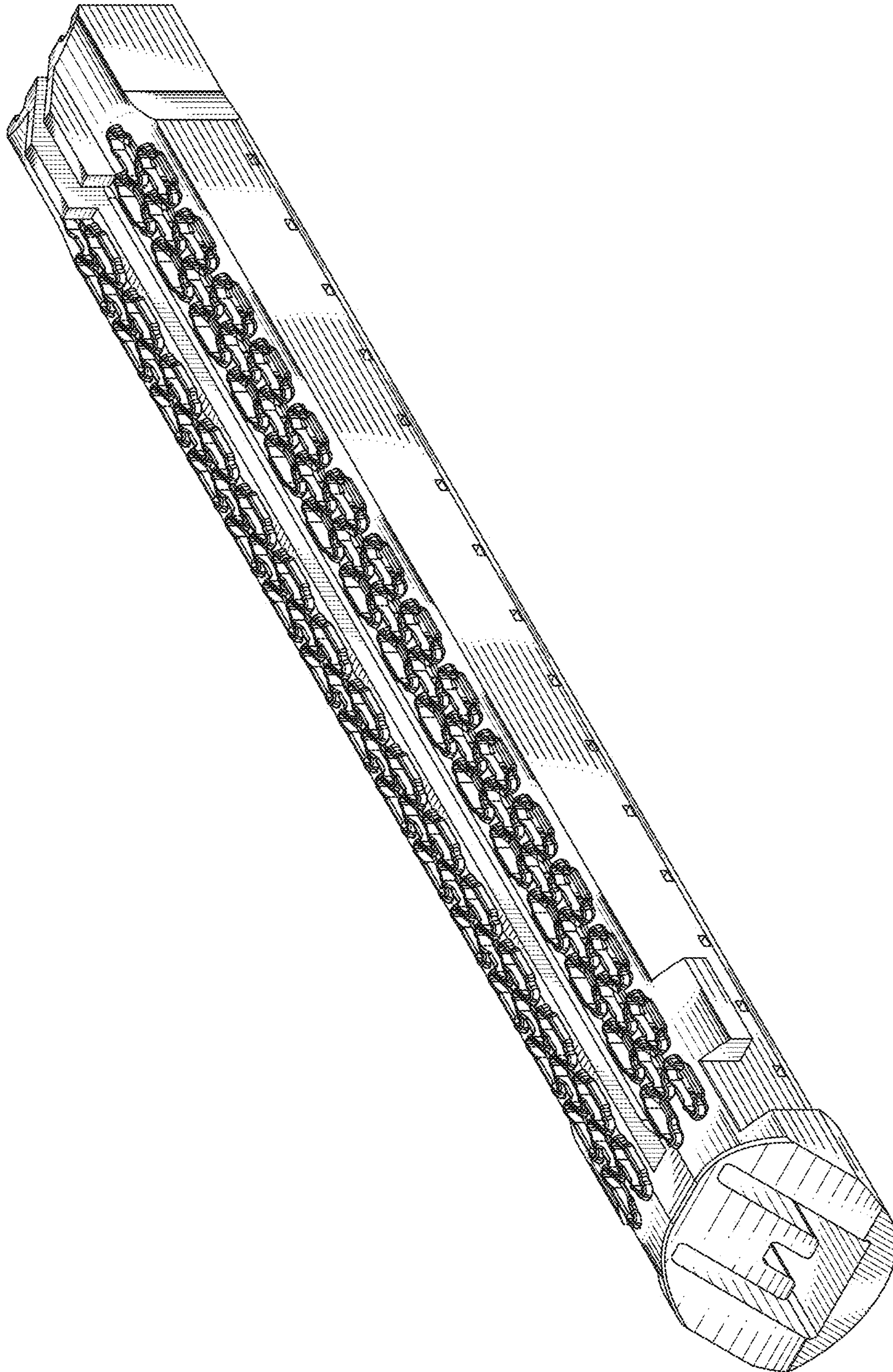

FIG. 8

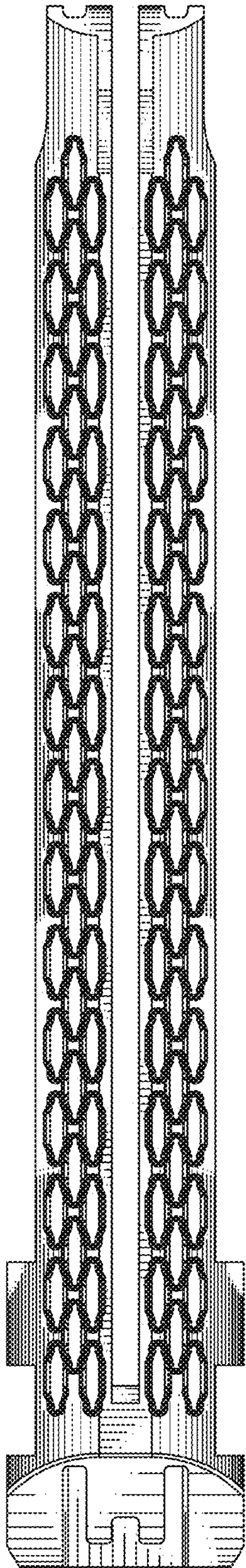

FIG. 9

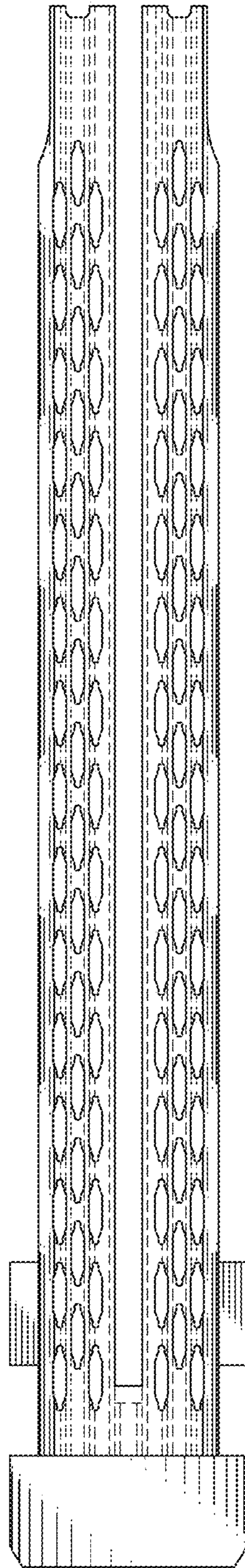

FIG. 10

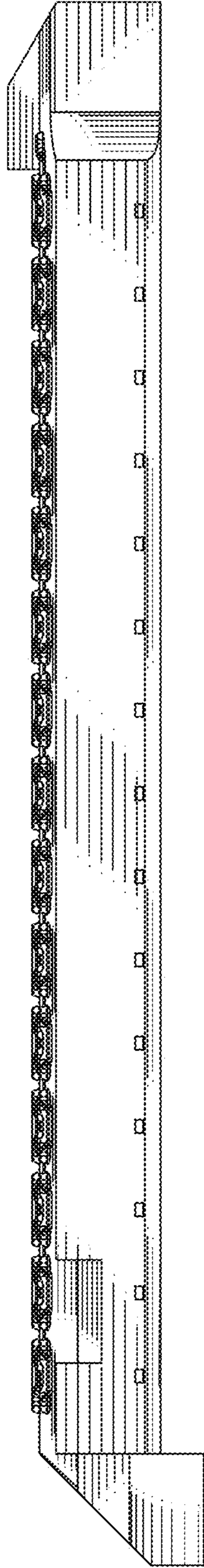

FIG. 11

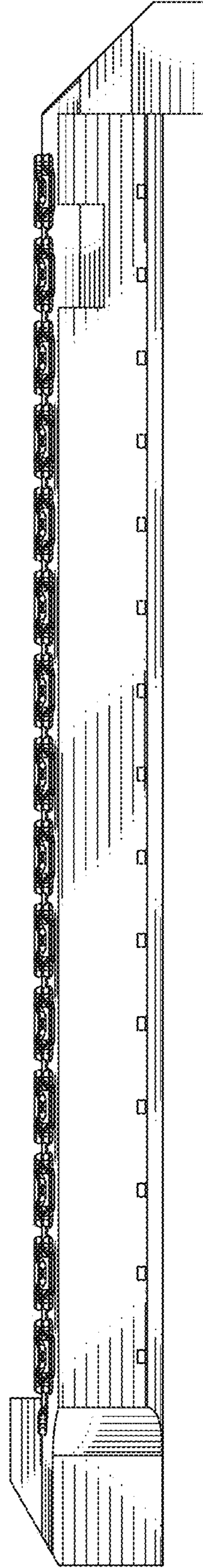

FIG. 12

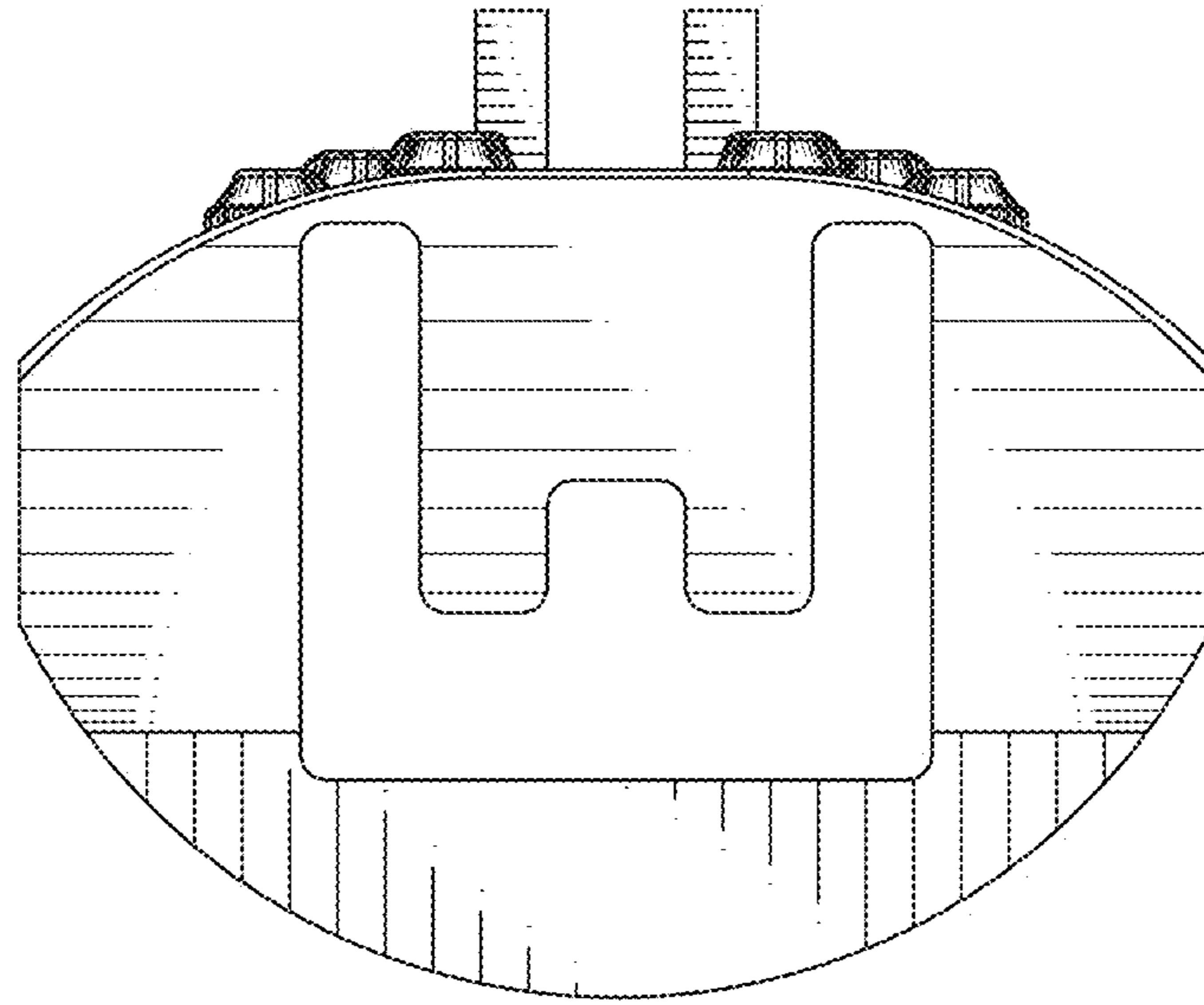

FIG. 13

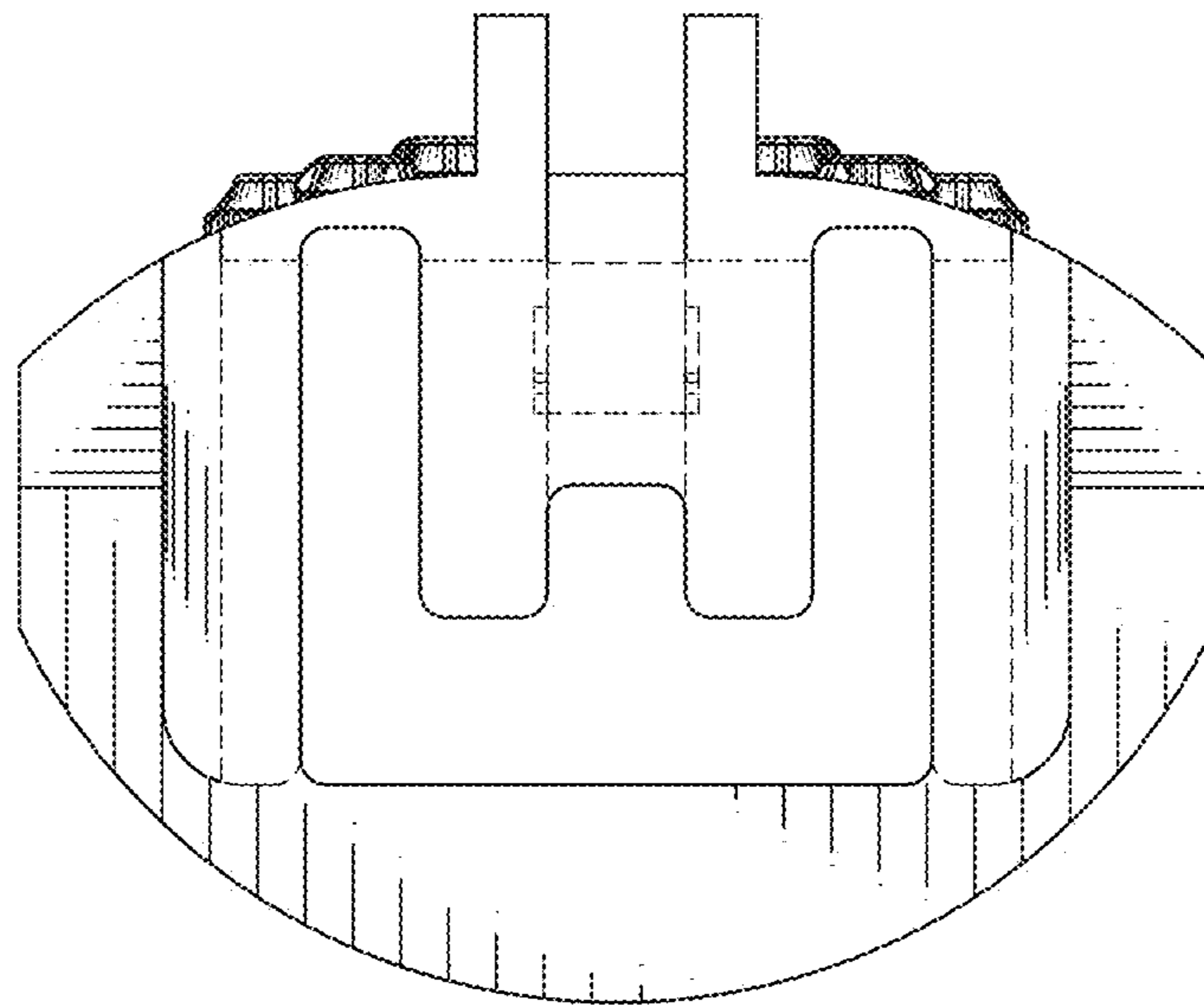

FIG. 14