



US00D974967S

(12) **United States Design Patent**  
**Sasanami et al.**

(10) **Patent No.:** **US D974,967 S**  
(45) **Date of Patent:** **\*\* Jan. 10, 2023**

(54) **MOTORCYCLE**  
(71) Applicant: **YAMAHA HATSUDOKI**  
**KABUSHIKI KAISHA**, Shizuoka-ken  
(JP)  
(72) Inventors: **Kazumasa Sasanami**, Tokyo (JP);  
**Shingo Kimata**, Shizuoka-ken (JP)  
(73) Assignee: **YAMAHA HATSUDOKI**  
**KABUSHIKI KAISHA**  
(\*\*) Term: **15 Years**

D755,084 S *	5/2016	Sakata	.....	D12/110
D755,680 S *	5/2016	Yashuhara	.....	D12/110
D755,681 S *	5/2016	Martin	.....	D12/110
D755,682 S *	5/2016	Hahn-Woernle	.....	D12/110
D756,268 S *	5/2016	Yamada	.....	D12/110
D758,923 S *	6/2016	Yamada	.....	D12/110
D758,924 S *	6/2016	Tamura	.....	D12/110
D782,368 S *	3/2017	Fujimoto	.....	D12/110
D795,746 S *	8/2017	Akita	.....	D12/110
D797,002 S *	9/2017	Toyama	.....	D12/110
D797,608 S *	9/2017	Tachibana	.....	D12/110
D801,230 S *	10/2017	Endo	.....	D12/110
D807,231 S *	1/2018	Petersson	.....	D12/110
D815,566 S *	4/2018	Oyanagi	.....	D12/110
D817,230 S *	5/2018	Tamura	.....	D12/110
D821,269 S *	6/2018	Sasanami	.....	D12/110

(Continued)

(21) Appl. No.: **29/781,541**

(22) Filed: **Apr. 30, 2021**

(30) **Foreign Application Priority Data**

Oct. 30, 2020 (JP) ..... 2020-023452

(51) **LOC (14) Cl.** ..... **12-11**

(52) **U.S. Cl.**  
USPC ..... **D12/110**

(58) **Field of Classification Search**  
USPC ..... D12/110, 111, 117; D21/432, 538  
CPC ..... B62K 11/00; B62K 11/02; B62K 11/04;  
B62K 11/10; B62K 17/00; B62K 19/00;  
B62K 2202/00

See application file for complete search history.

(56) **References Cited**

**U.S. PATENT DOCUMENTS**

D606,906 S *	12/2009	Chosa	.....	D12/110
D611,881 S *	3/2010	Toriyama	.....	D12/110
D643,341 S *	8/2011	Uchiyama	.....	D12/110
D647,825 S *	11/2011	Shibuta	.....	D12/110
D670,204 S *	11/2012	Yasuhara	.....	D12/110
D686,538 S *	7/2013	Nagao	.....	D12/110
D688,982 S *	9/2013	Oyanagi	.....	D12/110
D689,406 S *	9/2013	Yasuhara	.....	D12/110

**OTHER PUBLICATIONS**

“2022 Yamaha Tracer G GT.” Yamaha., Nov. 21, 2021 [online],  
[retrieved on Apr. 5, 2022]. Retrieved from the Internet <URL:  
[https://cdn2.yamaha-motor.eu/prod/product-assets/2021/MT09TRGT/Factsheets/2021-MT09TRGT\\_en.pdf](https://cdn2.yamaha-motor.eu/prod/product-assets/2021/MT09TRGT/Factsheets/2021-MT09TRGT_en.pdf)>.\*

(Continued)

*Primary Examiner* — Darlington Ly  
(74) *Attorney, Agent, or Firm* — Ostrolenk Faber LLP

(57) **CLAIM**

The ornamental design for a motorcycle, as shown.

**DESCRIPTION**

FIG. 1 is a front, left side, perspective view of a motorcycle showing our new design;  
FIG. 2 is a rear, right side, perspective view thereof;  
FIG. 3 is a front elevation view thereof;  
FIG. 4 is a rear elevation view thereof;  
FIG. 5 is a right side elevation view thereof;  
FIG. 6 is a left side elevation view thereof; and,  
FIG. 7 is a top plan view thereof.

**1 Claim, 7 Drawing Sheets**

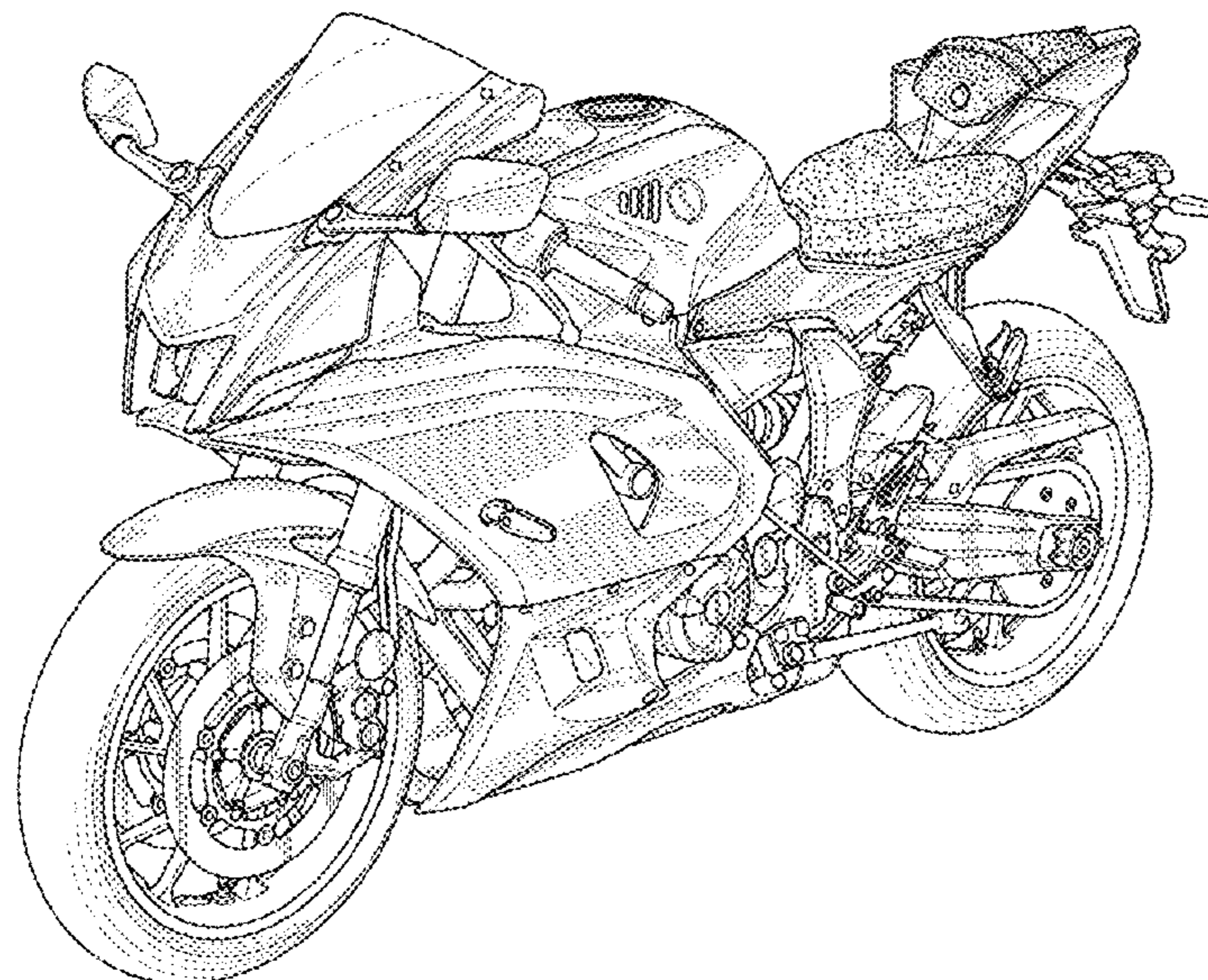

(56)

**References Cited**

## U.S. PATENT DOCUMENTS

D847,031	S	*	4/2019	Kobayashi	.....	D12/110
D849,602	S	*	5/2019	Oyanagi	.....	D12/110
D871,976	S	*	1/2020	Martin	.....	D12/110
D874,985	S	*	2/2020	Shigihara	.....	D12/110
D875,615	S	*	2/2020	Martin	.....	D12/110
D875,616	S	*	2/2020	Martin	.....	D12/110
D875,617	S	*	2/2020	Nagase	.....	D12/110
D876,990	S	*	3/2020	Yoshitomi	.....	D12/110
D884,562	S	*	5/2020	Usami	.....	D12/110
D902,083	S	*	11/2020	Arru	.....	D12/110
D911,223	S	*	2/2021	Kinoshita	.....	D12/110

## OTHER PUBLICATIONS

Jensen Beeler. "The 2021 Kawasaki Ninja ZX-10RR—\$29,000 & Only 500 Will Be Made." *Asphalt & Rubber*, Nov. 23, 2020 [online], [retrieved on Apr. 5, 2022]. Retrieved from the Internet <URL: <https://www.asphaltandrubber.com/bikes/2021-kawasaki-ninja-zx-10rr/>>.\*

Greg Drevenstedt. "2021 Yamaha Tracer 9 GT | Road Test Review." *Rider Motorcycling at its best.*, Jan. 5, 2022 [online], [retrieved on Apr. 5, 2022]. Retrieved from the Internet <URL: <https://ridermagazine.com/2022/01/05/2021-yamaha-tracer-9-gt-road-test-review/>>.\*

\* cited by examiner

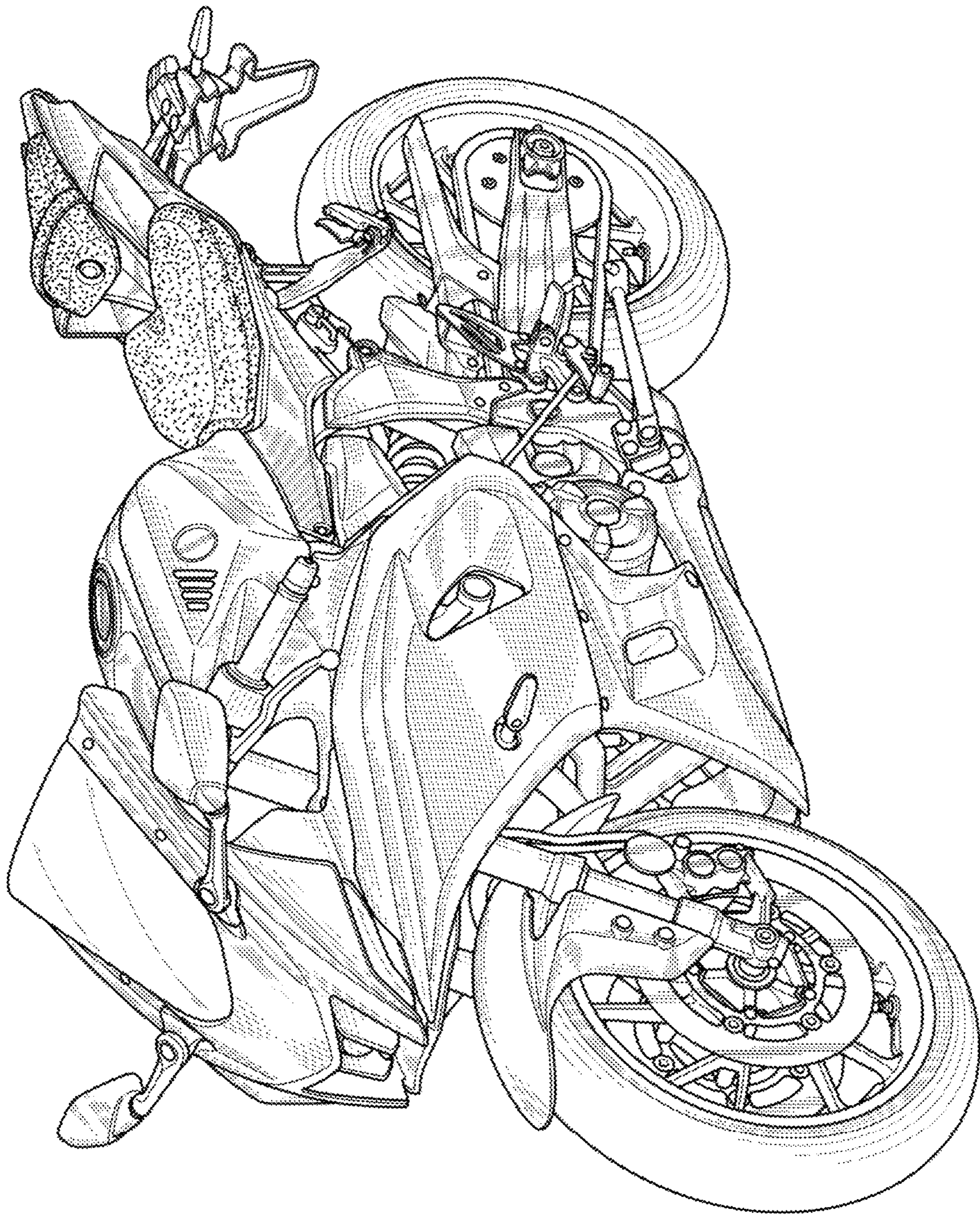
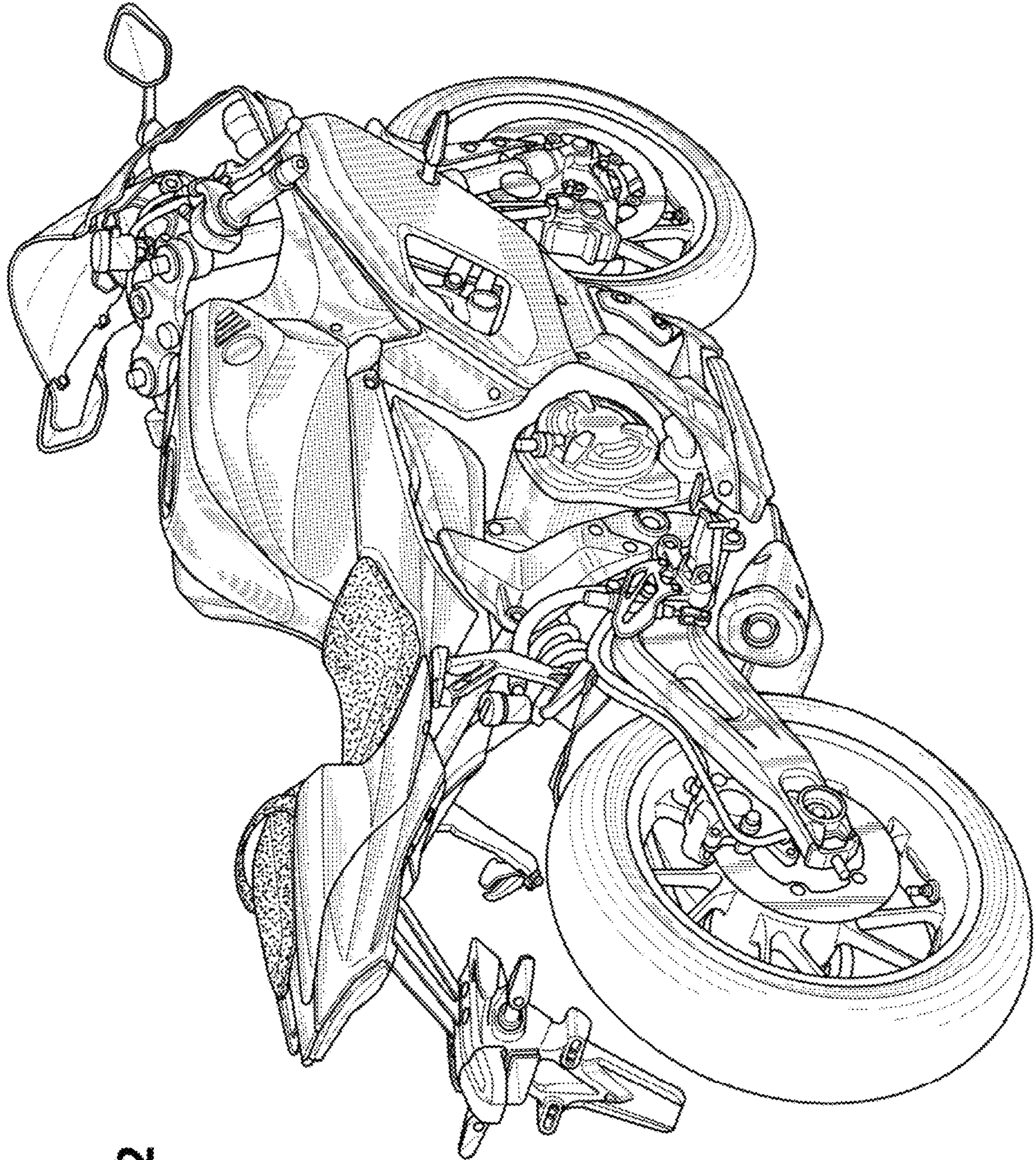

FIG. 1



**FIG. 2**

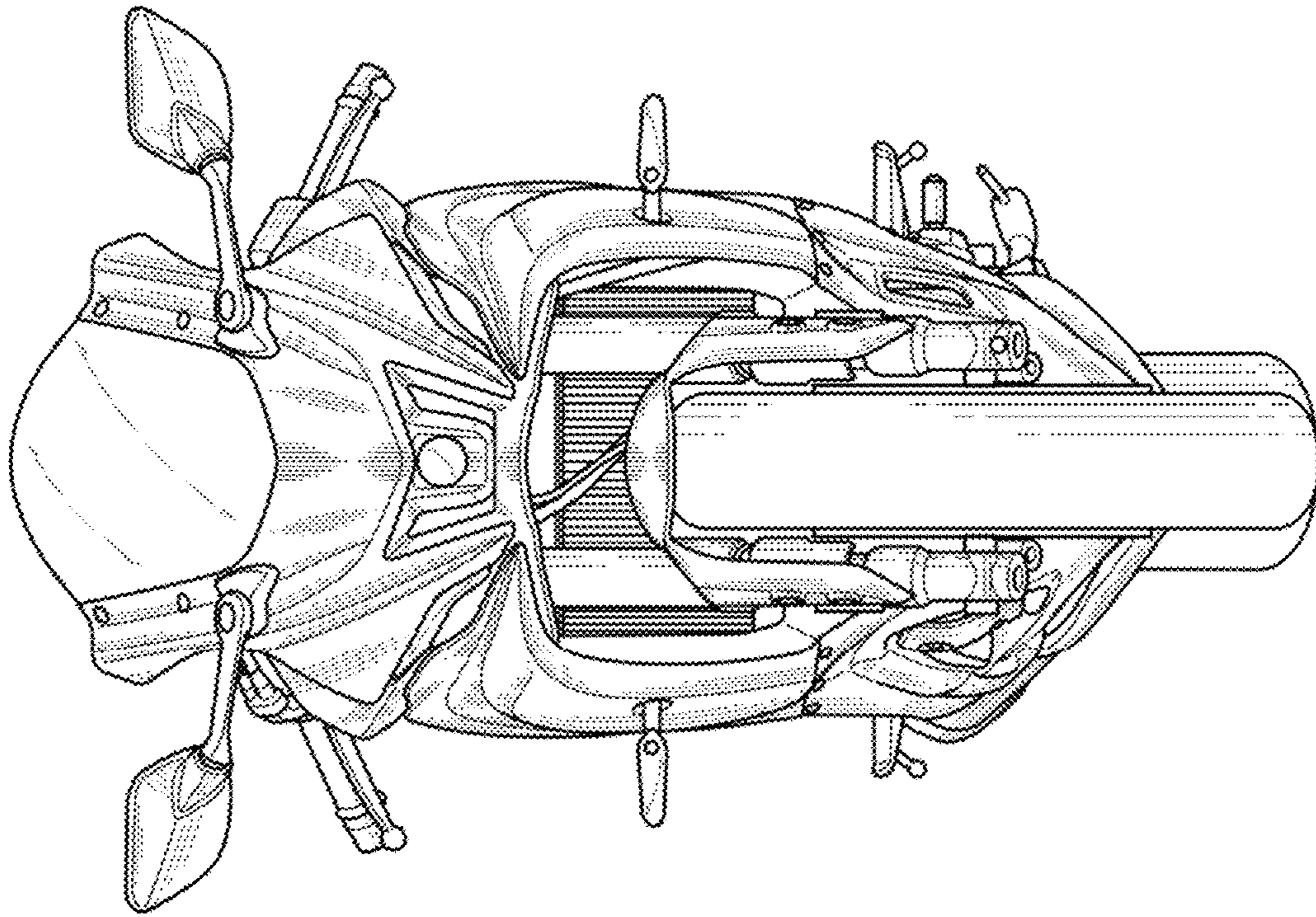

FIG. 3

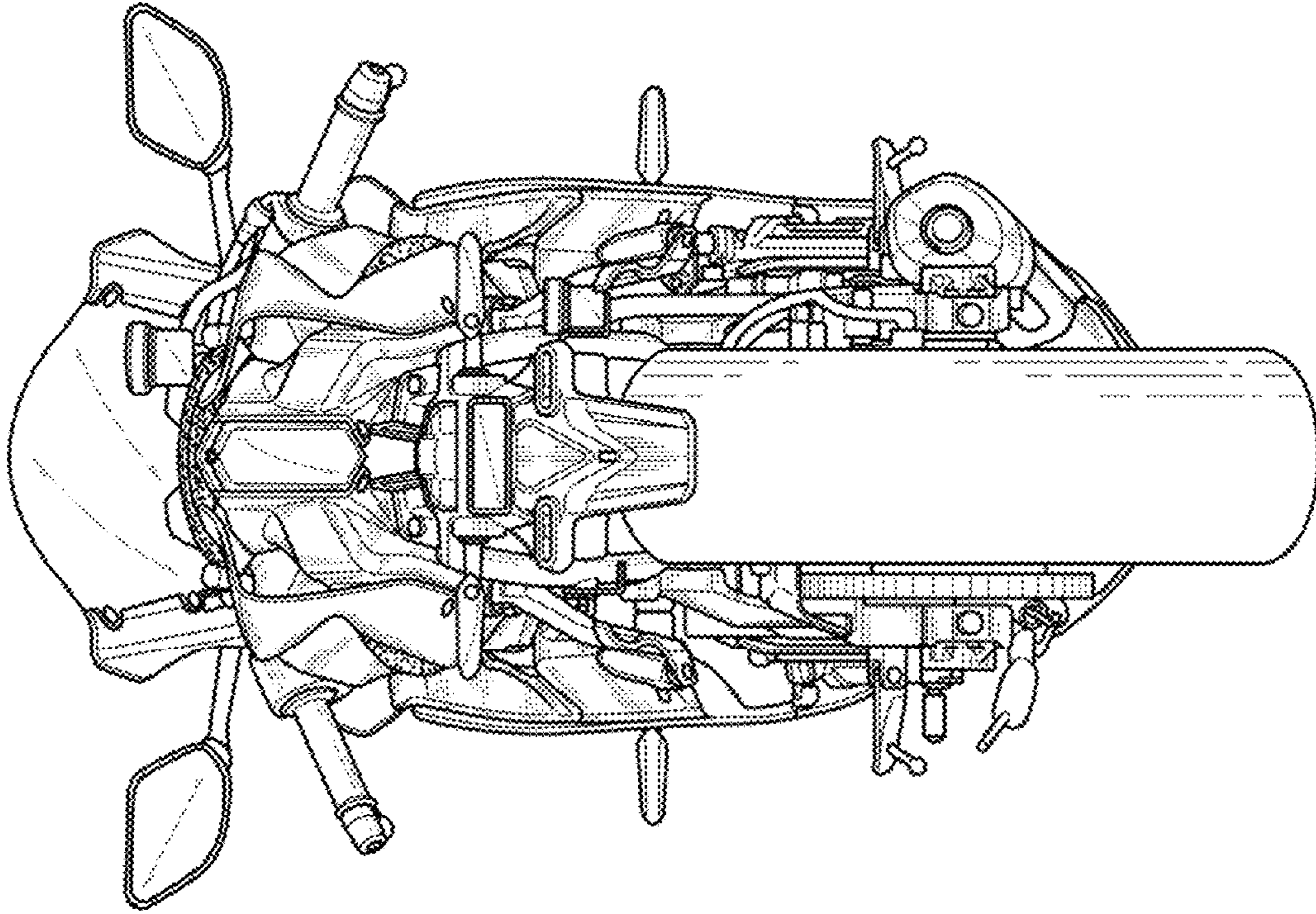

FIG. 4

FIG. 5

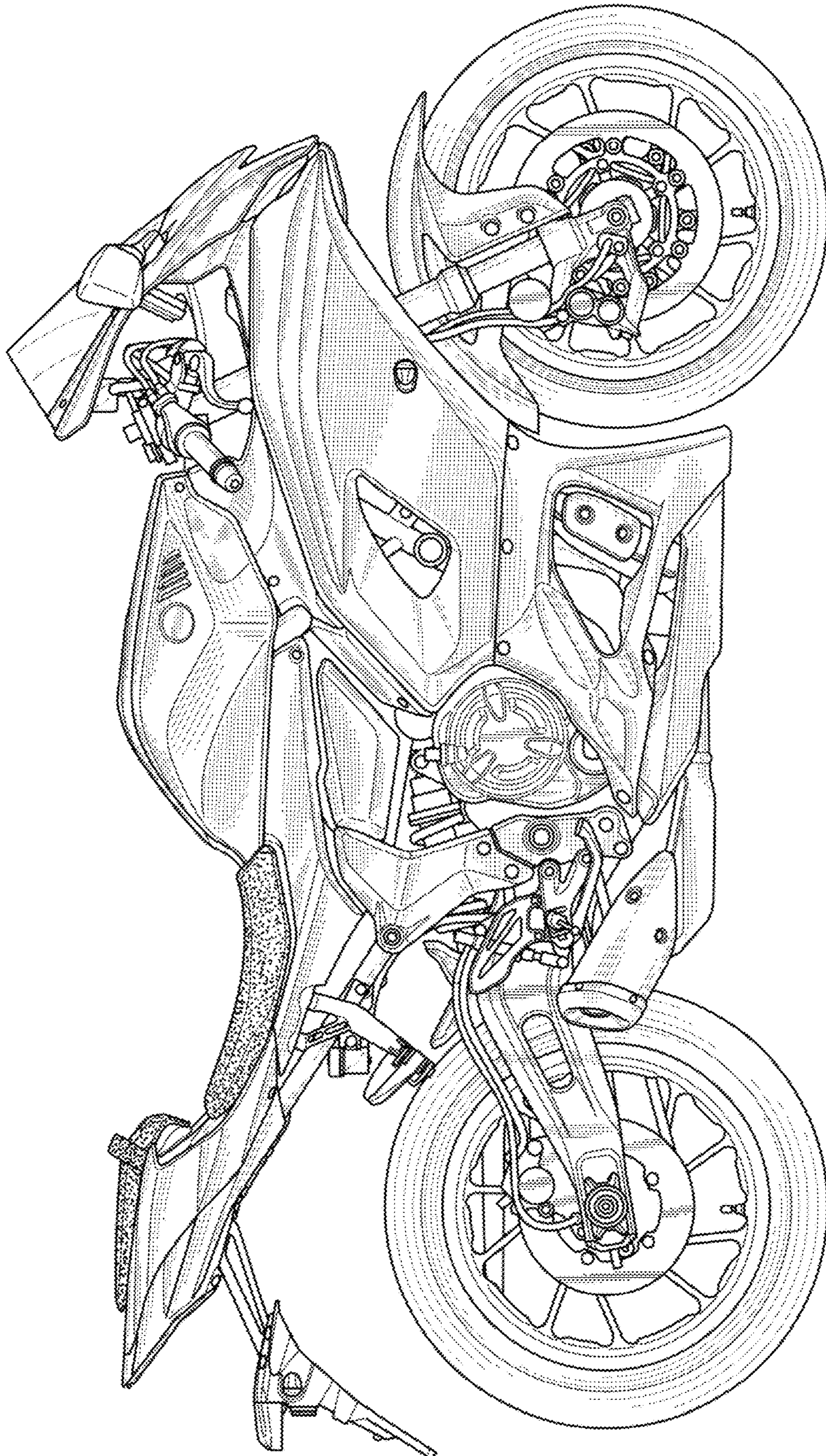

FIG. 6

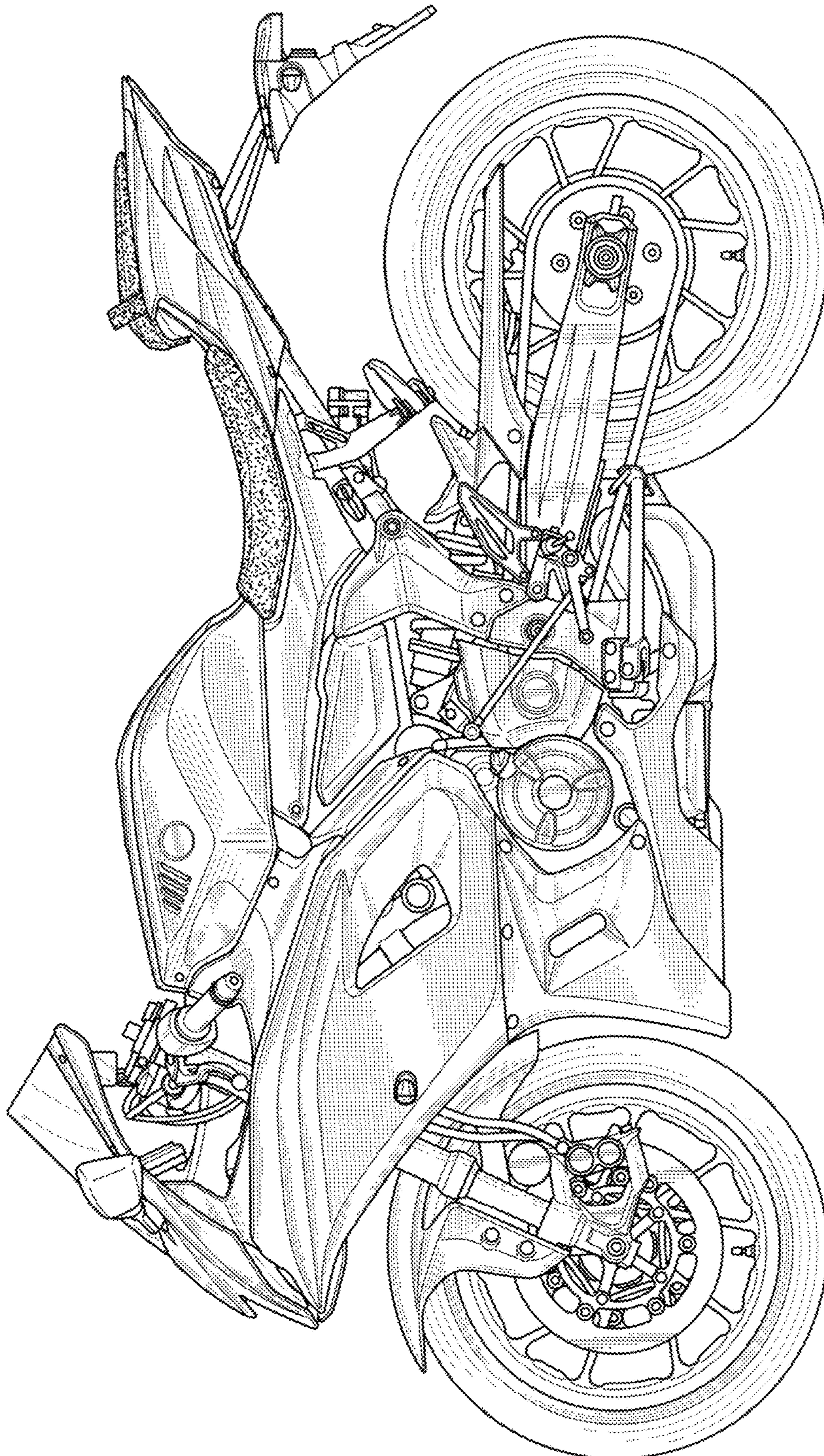



FIG. 7

