



US00D974436S

(12) **United States Design Patent** (10) **Patent No.:** **US D974,436 S**
Im et al. (45) **Date of Patent:** **** Jan. 3, 2023**

(54) **GOODS DELIVERY ROBOT**

FOREIGN PATENT DOCUMENTS

(71) Applicant: **NAVER LABS CORPORATION**,
Seongnam-si (KR)

DM 210451 11/2020
JP 1571378 S 3/2017
(Continued)

(72) Inventors: **Min-Kyo Im**, Seongnam-si (KR);
Kyumin Ha, Seongnam-si (KR)

OTHER PUBLICATIONS

(73) Assignee: **Naver Labs Corporation**, Gyeonggi-do
(KR)

Notice of Allowance dated Apr. 5, 2022 issued in corresponding
Japanese Design patent application No. 2021-013609.
(Continued)

(**) Term: **15 Years**

Primary Examiner — Patricia A Palasik
(74) *Attorney, Agent, or Firm* — Harness, Dickey &
Pierce, P.L.C.

(21) Appl. No.: **29/795,037**

(22) Filed: **Jun. 16, 2021**

(57) **CLAIM**

The ornamental design for a goods delivery robot, as shown
and described.

(30) **Foreign Application Priority Data**

DESCRIPTION

Dec. 24, 2020 (KR) 30-2020-0064791

(51) **LOC (14) Cl.** **15-99**

(52) **U.S. Cl.**
USPC **D15/199**

(58) **Field of Classification Search**
USPC D7/605, 606, 629; D12/14, 86, 88, 90,
D12/91; D15/199; D21/578-583, 621;
D34/34
CPC B25J 5/007; B25J 11/008; B60G 5/01;
B60G 2300/07; Y10S 901/01
See application file for complete search history.

FIG. 1 is a top front perspective view of a goods delivery
robot, showing our new design.
FIG. 2 is a front plan view of the goods delivery robot shown
in FIG. 1.
FIG. 3 is a rear plan view of the goods delivery robot shown
in FIG. 1.
FIG. 4 is a left plan view of the goods delivery robot shown
in FIG. 1.
FIG. 5 is a right plan view of the goods delivery robot shown
in FIG. 1.
FIG. 6 is a top plan view of the goods delivery robot shown
in FIG. 1.
FIG. 7 is a bottom plan view of the goods delivery robot
shown in FIG. 1; and,
FIG. 8 is a top front perspective view of the goods delivery
robot for the use state of FIG. 1.
The broken lines shown in the drawings illustrate the
portions of the design that form no part of the claimed
design.

(56) **References Cited**

U.S. PATENT DOCUMENTS

D620,511 S * 7/2010 Publ D23/207
D644,256 S * 8/2011 Kitano D15/199
D700,923 S * 3/2014 Lin D15/199
D821,265 S * 6/2018 Mäkelä D3/271.12
D822,739 S * 7/2018 Kato D15/199
D826,302 S * 8/2018 Tsukamoto D15/199

(Continued)

1 Claim, 8 Drawing Sheets

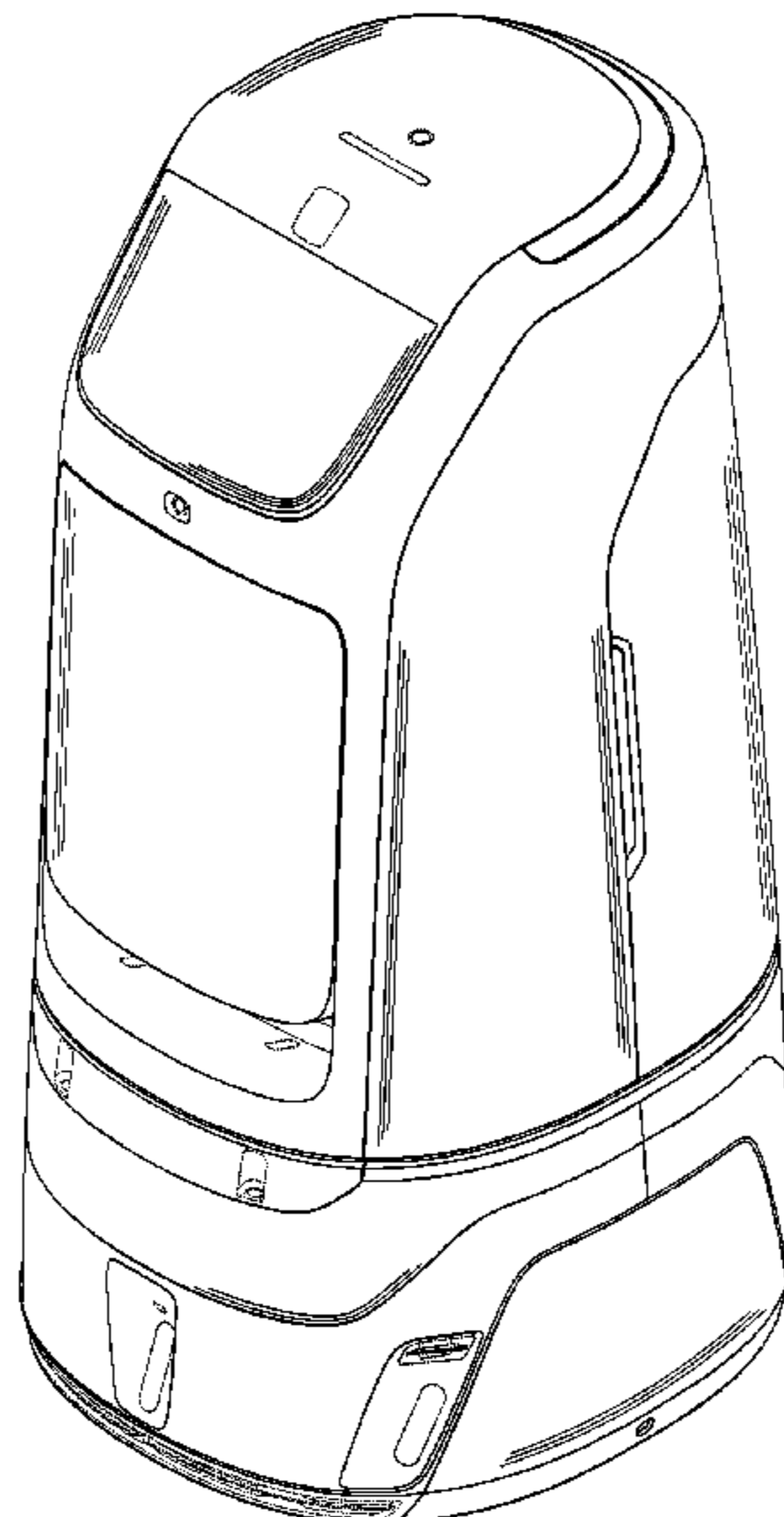

(56)

References Cited

U.S. PATENT DOCUMENTS

D840,619 S * 2/2019 Kim A47J 37/0713
D15/199
D869,533 S * 12/2019 Kim A63H 11/00
D15/199
D870,787 S * 12/2019 Kim D15/199
D871,474 S * 12/2019 Kolb D15/199
D879,174 S * 3/2020 Kammermeier D15/199
10,576,617 B1 * 3/2020 Asada B25J 11/008
D881,961 S * 4/2020 Bergeron D15/199
D883,353 S * 5/2020 Zhang D15/199
D883,354 S * 5/2020 Jafarzadeh D15/199
D884,043 S * 5/2020 Song D15/199
D888,790 S * 6/2020 Yao D15/199
D908,151 S * 1/2021 Song D15/199
D908,152 S * 1/2021 Cacioppo D15/199
D908,153 S * 1/2021 Cacioppo D15/199
D909,441 S * 2/2021 Zhao D15/199
D909,442 S * 2/2021 Zhao D15/199
D915,486 S * 4/2021 Gidwell D15/199
D918,978 S * 5/2021 Li D15/199
D919,687 S * 5/2021 Song D15/199
D921,083 S * 6/2021 Hernandez D15/199
D922,465 S * 6/2021 Lee B25J 11/00
D15/199
D924,956 S * 7/2021 Pajevic D15/199
D931,921 S * 9/2021 Haddadin D15/199
D934,932 S * 11/2021 Han D15/199
D934,933 S * 11/2021 Cho D15/199
D934,934 S * 11/2021 Park D15/199
D939,004 S * 12/2021 Gidwell D15/199
D939,602 S * 12/2021 Wang B25J 11/00
D15/199
D944,305 S * 2/2022 Liu D15/199

D947,915 S * 4/2022 Li D15/199
2005/0216126 A1 * 9/2005 Koselka B25J 5/007
700/259
2016/0114488 A1 * 4/2016 Mascorro Medina B25J 11/008
901/1

FOREIGN PATENT DOCUMENTS

JP 1662803 S 6/2020
JP 1694165 S 9/2021
JP 1702825 S 12/2021
JP 1704690 S 1/2022
KR 300937659 12/2017
WO WO-2022019376 A1 * 1/2022

OTHER PUBLICATIONS

RC03004065 “Autonomous delivery robot, transfer robot, customized robot general-purpose trolley, disinfection robot.” “Delivery robot.” Fingal Link Co., Ltd., Dec. 18, 2020.
Japanese Notice of Allowance dated Nov. 2, 2021, issued in corresponding Japanese Patent Application No. 2021-013608.
Sang-ok Seok “Around D” Nov. 27, 2020, <<https://tv.naver.com/v/16913099/list/657024>>.
Internet Article, “Naver Labs unveils ‘Around D’, an autonomous driving robot and ‘Ambidex’, a robot that implements kinetic intelligence.” Nov. 17, 2020.
Internet Article, “Naver Labs unveils robot technology research results”, Nov. 12, 2020.
Internet Article, “A robot arm that cuts vegetables with a knife, a robot that carries home delivery”, Nov. 11, 2020.
Junho Oh et al., People for Machines and Robots, Nov. 11, 2020.

* cited by examiner

FIG. 1

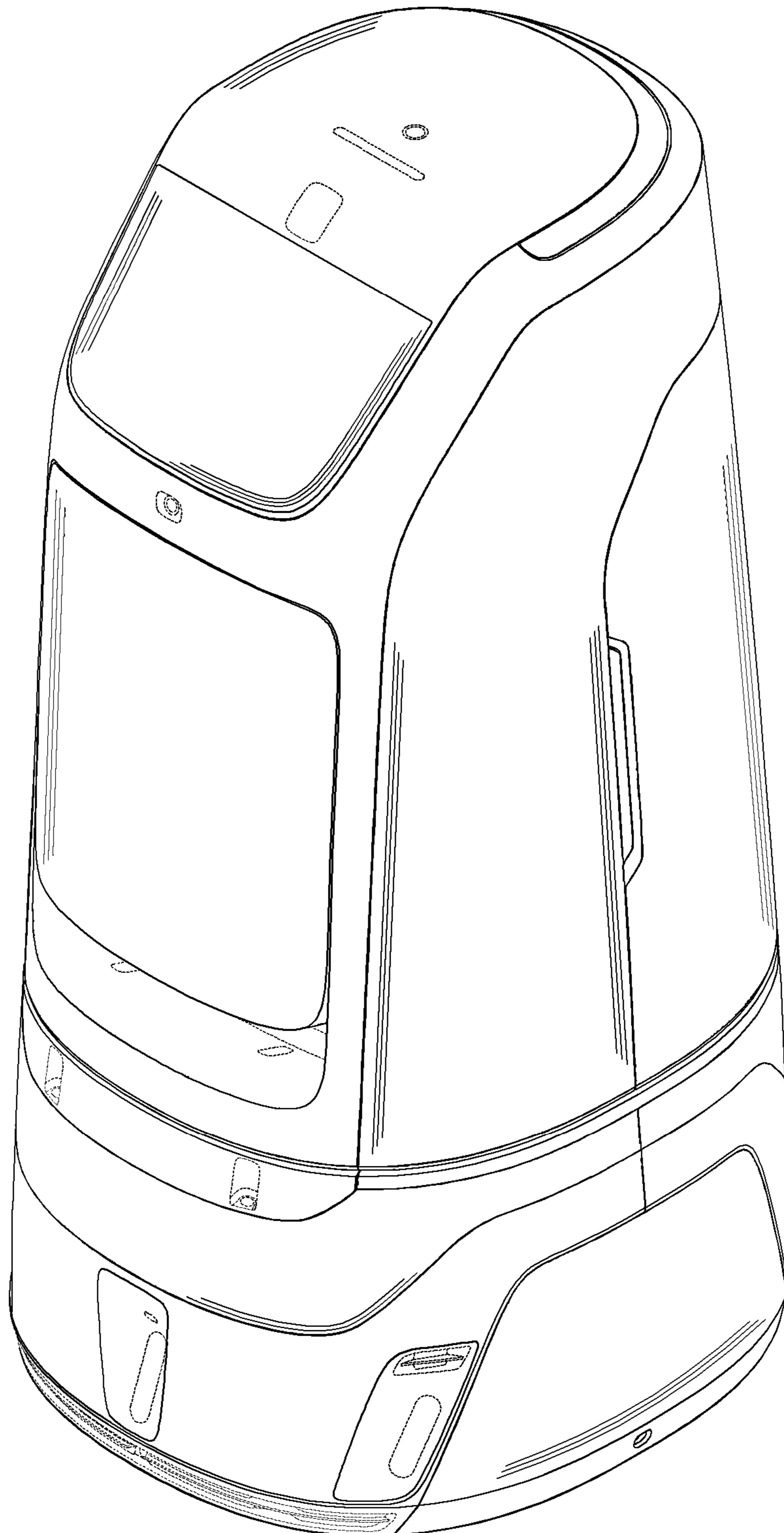

FIG. 2

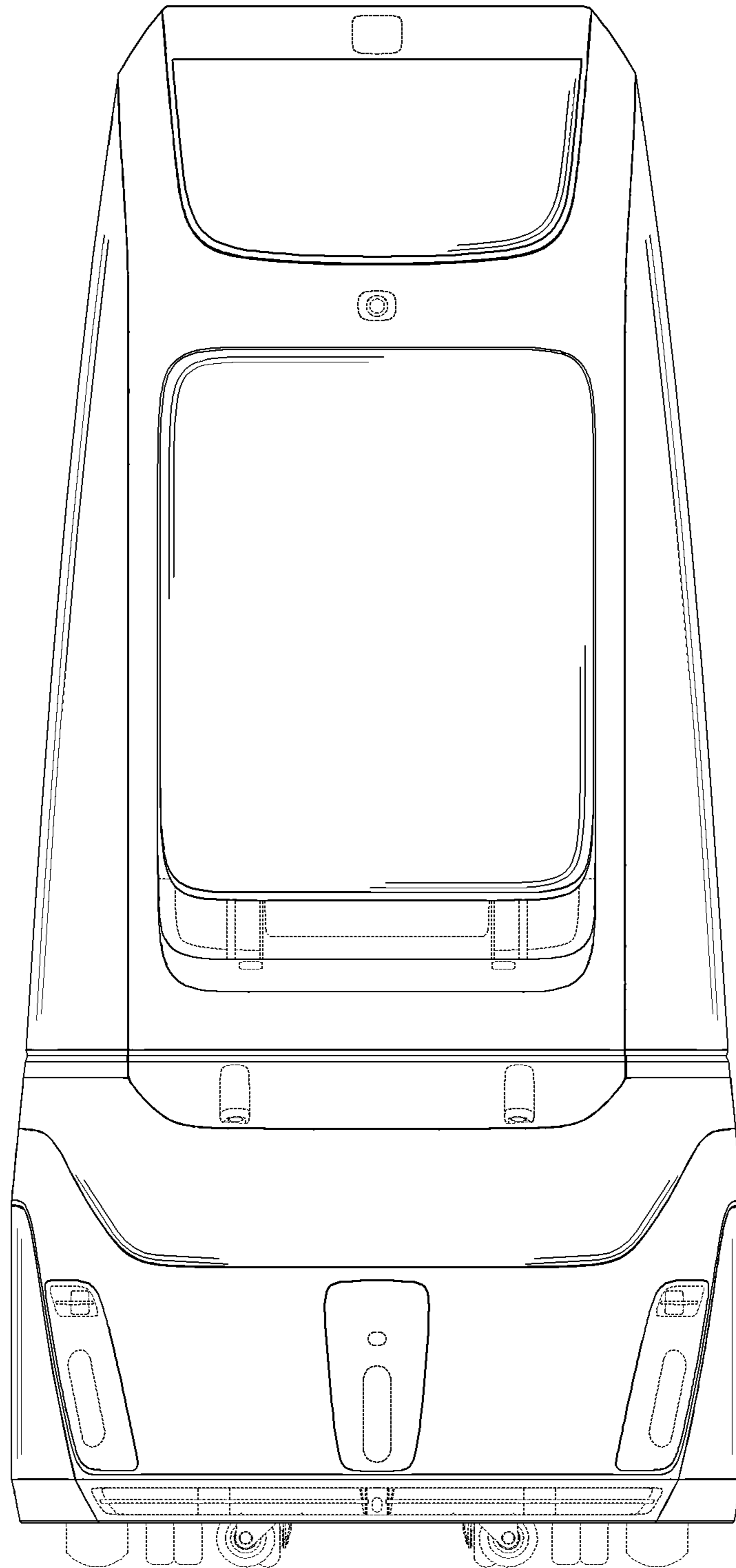

FIG. 3

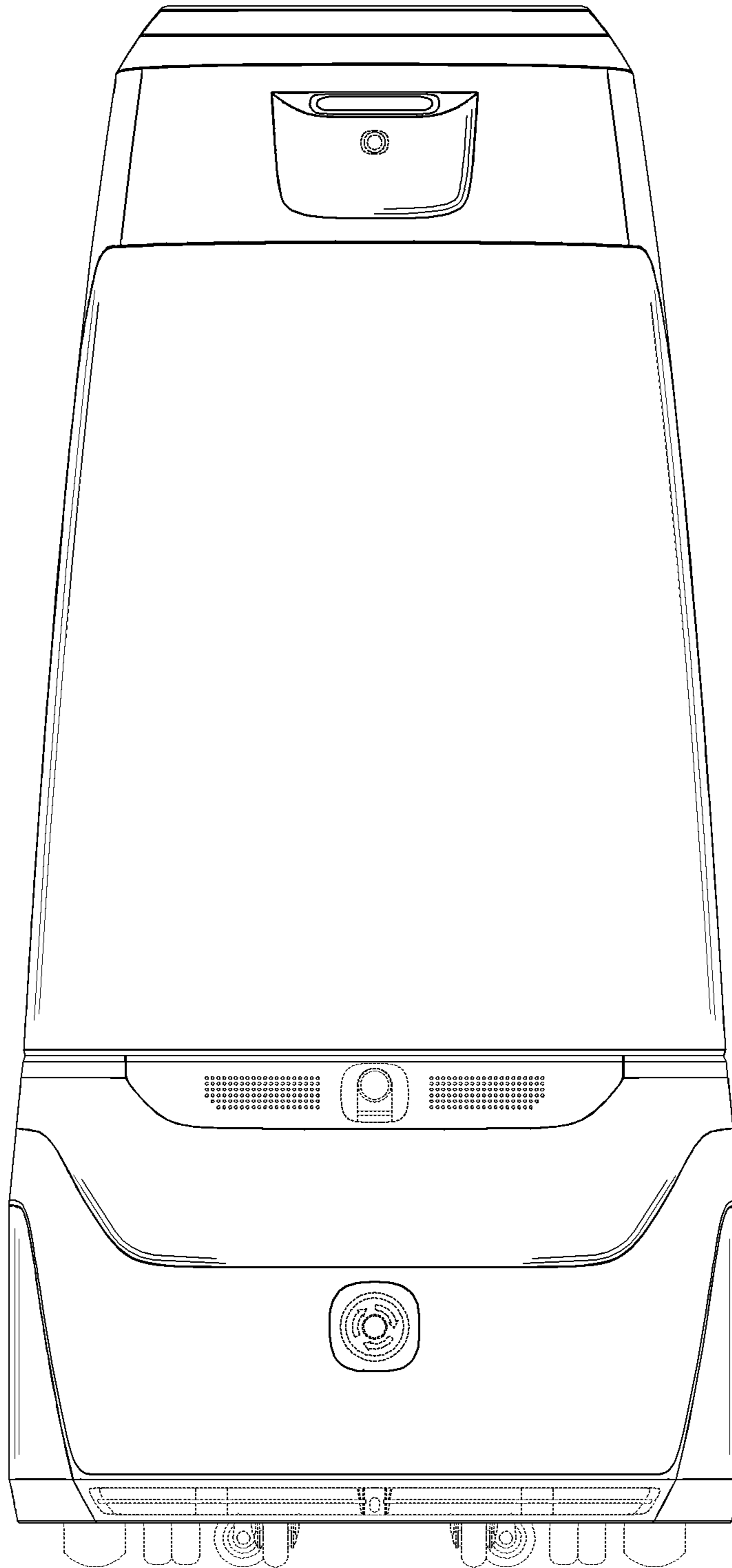

FIG. 4

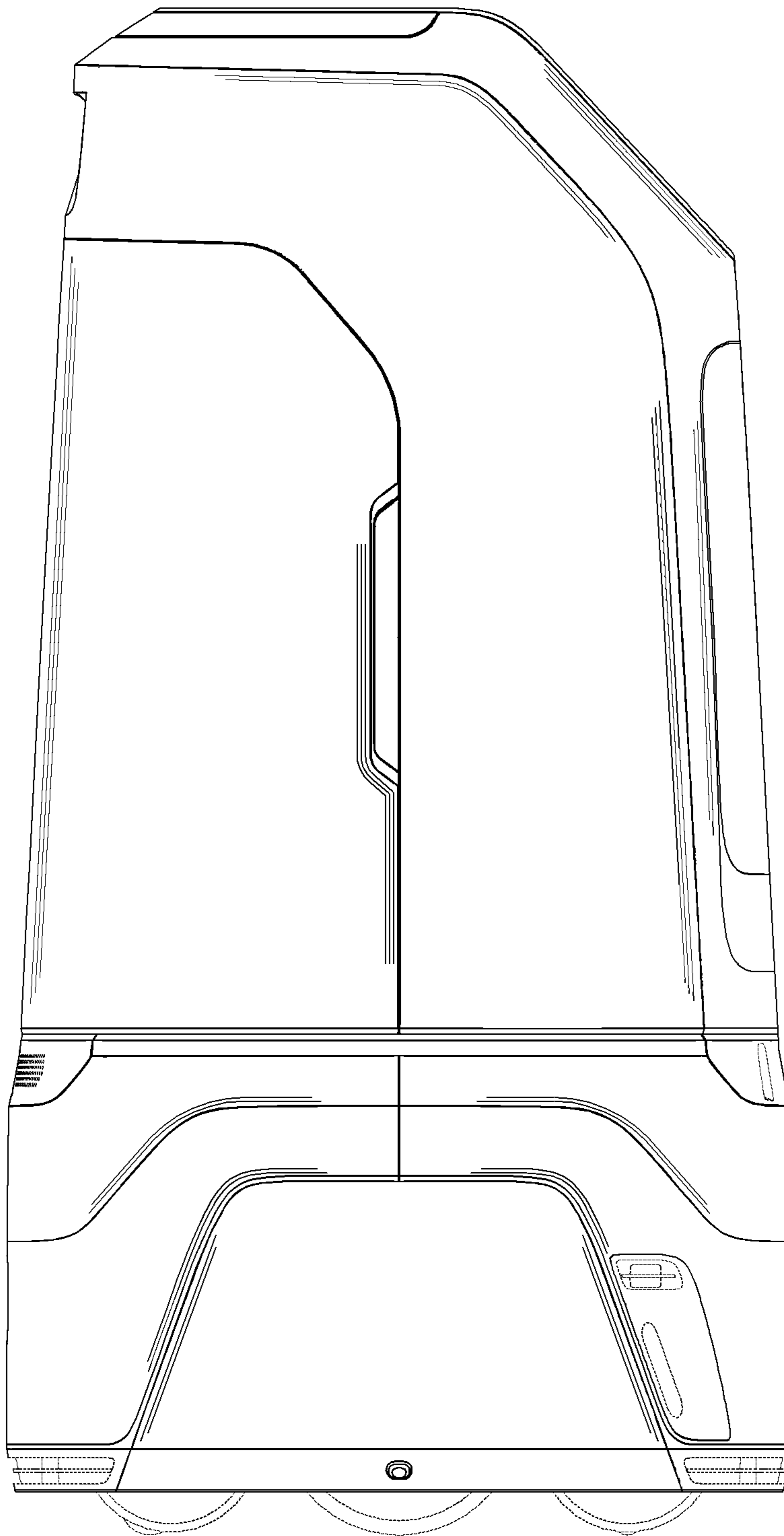

FIG. 5

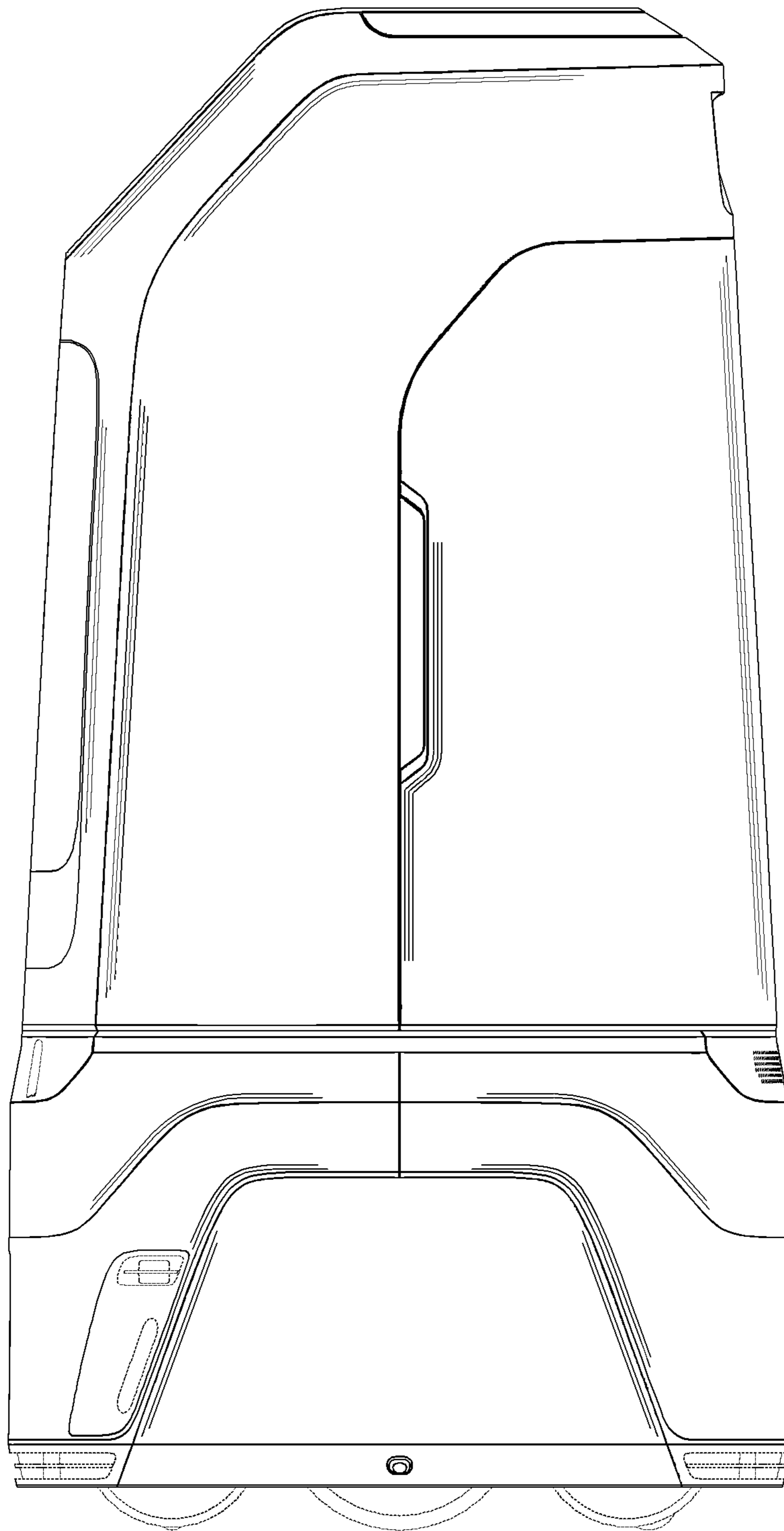

FIG. 6

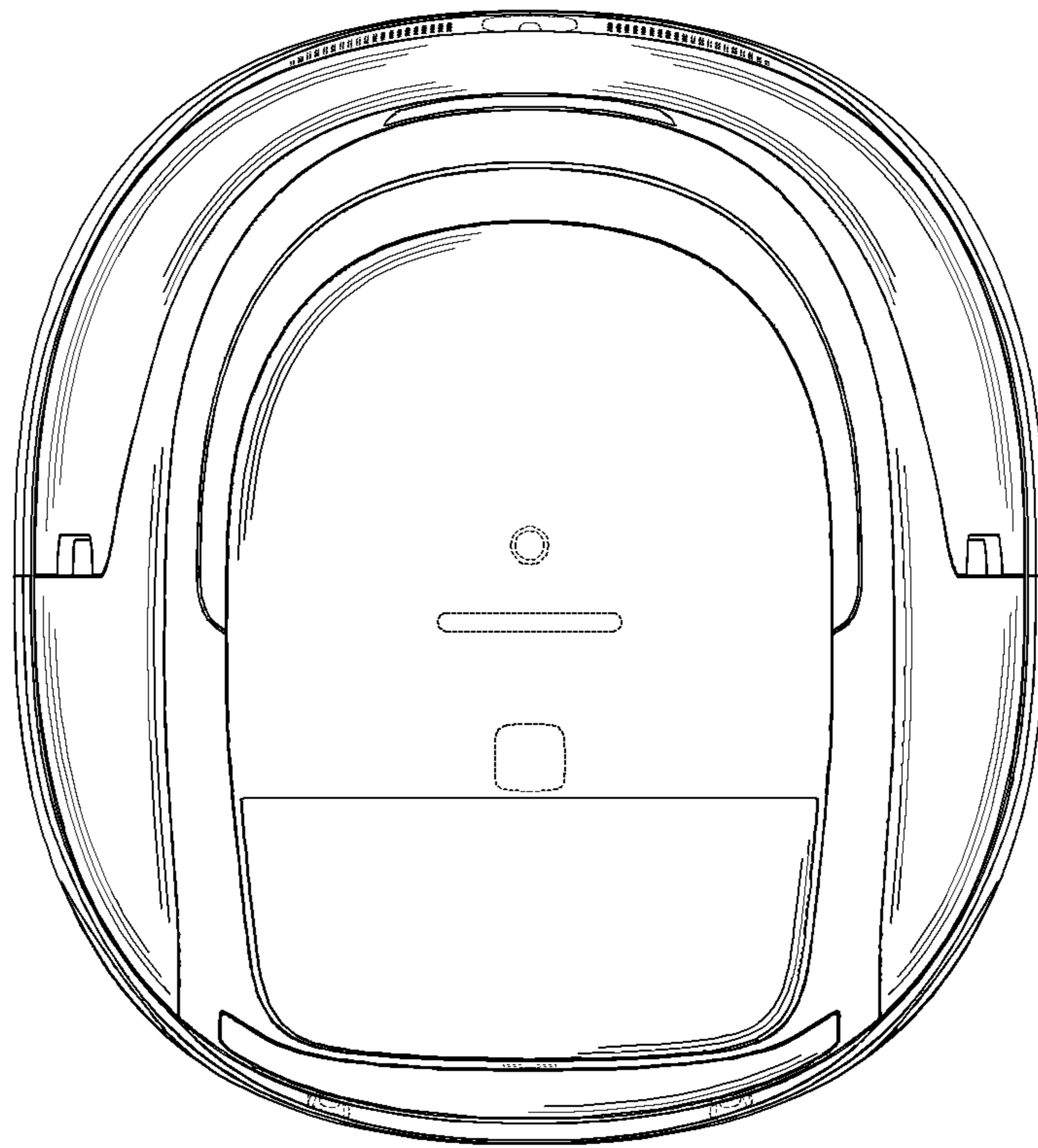

FIG. 7

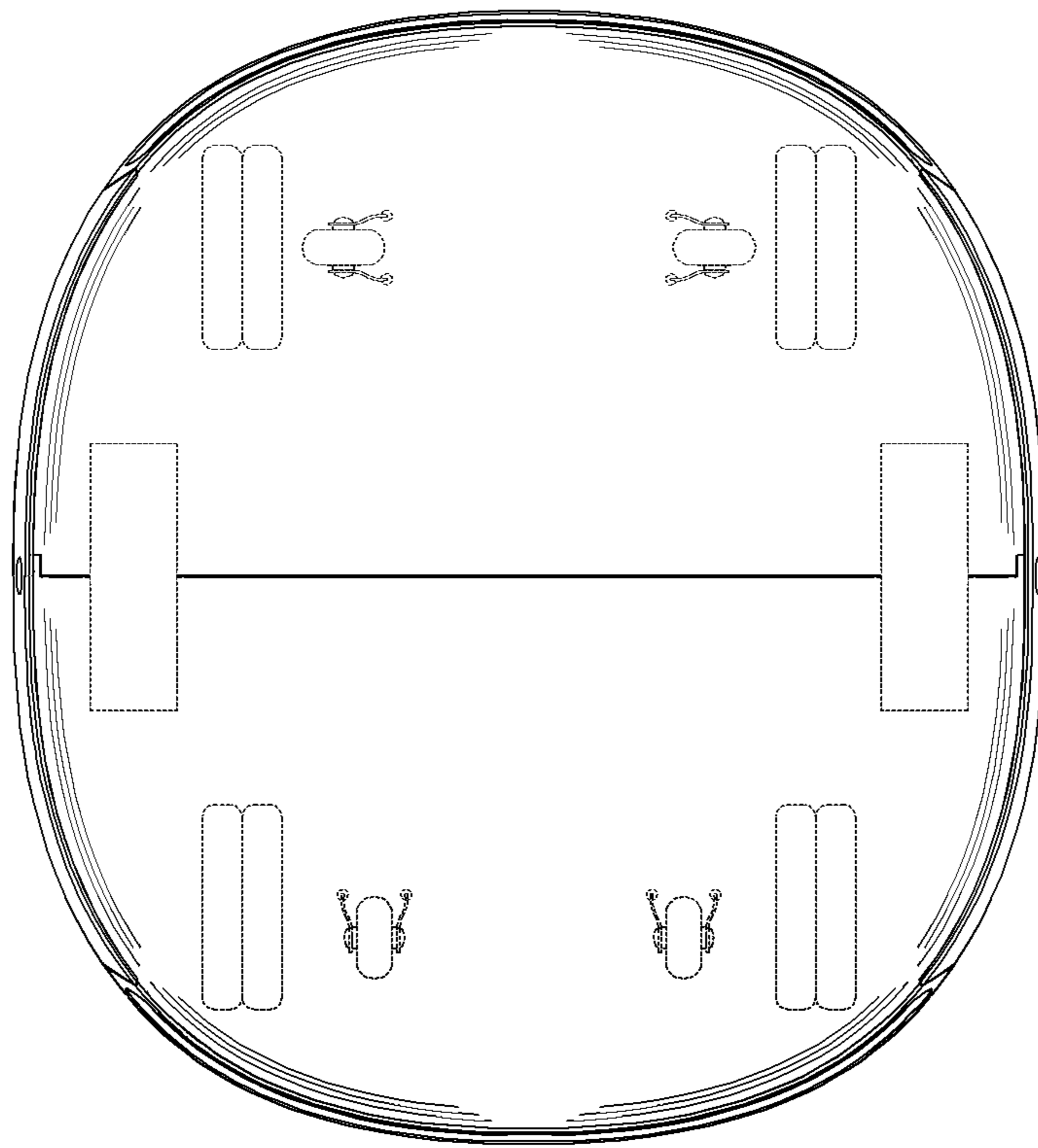

FIG. 8

